

K600-1811-2024
February 23, 2024



SW-C1811

PROJECT MANUAL

FOR

DAY USE DEVELOPMENT

AT

KOPACHUCK STATE PARK

IN

PIERCE COUNTY

BID OPENING: 1:00 P.M., THURSDAY, APRIL 25TH, 2024

WASHINGTON STATE PARKS & RECREATION COMMISSION
1111 ISRAEL ROAD SW
TUMWATER, WA 98501-6512
POST OFFICE BOX 42650
OLYMPIA, WASHINGTON 98504-2650



PROJECT MANUAL

FOR

DAY USE DEVELOPMENT

AT

KOPACHUCK STATE PARK

IN

PIERCE COUNTY

Approved for Construction

Heather Saunders
Heather Saunders, Director of Parks Development

WASHINGTON STATE PARKS AND RECREATION COMMISSION
1111 ISRAEL ROAD SW
TUMWATER, WASHINGTON 9501-6512
P.O. BOX 42650
OLYMPIA, WASHINGTON 98504-2650

WASHINGTON STATE PARKS AND RECREATION COMMISSION

KOPACHUCK STATE PARK DAY USE DEVELOPMENT

The Professional Engineer's Seals and signatures affixed hereon indicates this engineer's review and participation in the preparation of Divisions 2 through 33 of these Technical Specifications.

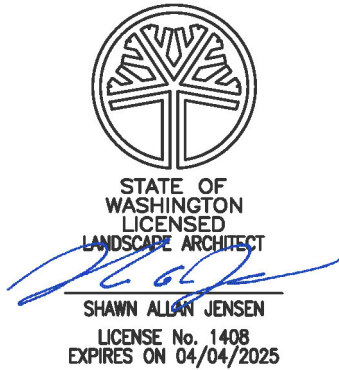

Shawn A. Jensen, PLA
Name

Bruce Dees & Associates, LLC
Firm

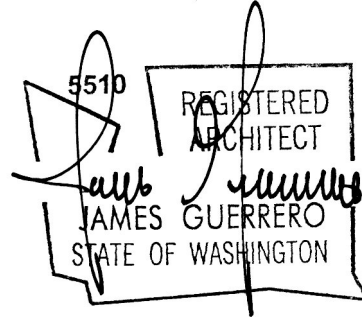

James Guerrero, AIA
Name

James Guerrero Architects, Inc.
Firm



Gary Watters, PE
Name

PND Engineers, Inc.
Firm



Chris Fote, PE
Name

Stantec, Inc.
Firm

Diana Dupuis,
Director



STATE OF WASHINGTON
WASHINGTON STATE PARKS AND RECREATION COMMISSION

1111 Israel Road SW • PO Box 42650 • Olympia, WA 98504-2650 • (360) 902-8500
Internet Address: <http://www.parks.wa.gov>

March 22, 2024

Re: **Letter of Advertisement – Kopachuck State Park – Day Use Development – SW-C1811**

To whom it may concern:

Please publish the following legal advertisement under your “Advertisement for Bid” section for two (2) consecutive days beginning on **Monday, March 25, 2024**, or at your earliest possible convenience. An Affidavit of Publication will be required by this office. A voucher form is enclosed for your convenience in billing.

ADVERTISEMENT FOR BID

Sealed proposals will be received for the following project:

Kopachuck State Park – Day Use Development

PROJECT DESCRIPTION:	The Kopachuck State Park Day Use Development project consists of removal of an existing restroom building, construction of a new Day Use Building and deck, Welcome Center building, wood decks, ramps, and stairs, wood amphitheater, concrete ADA accessible paths, picnic areas, play area elements, play tower structure, faux water feature, park entry gateway and sign, concrete walls, paved one-way parking lot with 98 stalls, vehicular gates, and school connector trail / pathway along the south side of 56 th St NW. Work includes clearing, grading, concrete, asphalt, sanitary sewer, storm sewer, domestic water, electrical systems, CCTV system, and landscape planting.
PROJECT LOCATION:	The project is located at Kopachuck State Park, 10712 56 th St NW, Gig Harbor 98335 in Pierce County
ESTIMATED BID RANGE:	\$ 6,650,000.00 - \$ 7,500,000.00
BID OPENING TIME:	1:00 PM on Thursday, April 25, 2024
PREBID WALKTHROUGH:	10:00 AM on Thursday, April 11, 2024. Meet at the Main Day Use Parking Lot. Location: https://maps.app.goo.gl/ZqwhMCYAj7z9JNJ16

PLANS, SPECIFICATIONS, ADDENDA, AND PLAN HOLDERS LIST: Are available on-line through Builders Exchange of Washington, Inc. at <http://www.bxwa.com>. Click on: "bxwa.com"; "Posted Projects"; "Public Works", "Washington State Parks & Recreation", and "**04/25/2024**". (Note: Bidders are encouraged to "Register as a Bidder", in order to receive automatic email notification of future addenda and to be placed on the "Bidders List". This service is provided free of charge to Prime Bidders, Subcontractors, and Vendors bidding this project.)

"PLANS MAY ALSO BE VIEWED THROUGH: Builders Exchange, Everett WA; Associated Builders And Contractors, Spokane WA; Tri City Construction Council, Kennewick WA; Daily Journal of Commerce, Seattle WA; Weekly Construction Reporter, Bellingham WA; Daily Journal Of Commerce Plan Center, Portland OR; Southwest Washington Contractors Association, Vancouver WA; Lower Columbia Contractor Plan Center, Longview WA.

Technical questions regarding this project shall be directed to: *Brian Yearout, Project Representative at telephone: (360) 725-9763, email: brian.yearout@parks.wa.gov, 1111 Israel Rd SW, Tumwater, WA 98501, Fax (360) 664-0312.*

Bidder Responsibility will be evaluated for this project. In determining bidder responsibility, the Owner shall consider an overall accounting of the criteria set forth in Division 00 – Instructions To Bidders. Please direct questions regarding this subject to the office of the Project Engineer.

Voluntary numerical MWBE goals of 10% MBE and 6% WBE have been established for this project. Achievement of the goals is encouraged. Bidders may contact the Office of Minority and Women's Business Enterprise to obtain information on certified firms.

Mandatory 15% apprentice labor hours of the total labor hours are a requirement of this construction contract. Voluntary workforce diversity goals for this apprentice participation are identified in the Instructions to Bidders. Bidders may contact the Department of Labor & Industries, Apprenticeship Section, to obtain information on available apprenticeship programs.

Washington State Parks reserves the right to accept or reject any or all proposals and to waive informalities.

Sincerely,

Brett Taylor, Contracts Specialist
Contracts and Grants Program

BAT

cc: Darell Hopkins, Region Manager
Kyle Murphy, Capital Program Manager
Brian Yearout, Project Representative
Park Manager
OWMBE

**KOPACHUCK STATE PARK
DAY USE DEVELOPMENT**

"ADVERTISEMENT FOR BID" LETTERS

INVITATION TO BID i – ii

INSTRUCTIONS TO BIDDERS 13 pages

AVAILABLE INFORMATION

Appendix A – Hazardous Materials Survey Report 2/10/2021 19 pages

Appendix B - Geotechnical Engineer's Site Exploration Logs 9 pages

Environmental Transmittal Letter 77 pages

SUMMARY OF PAY ITEMS AND QUANTITIES 5 pages

BID PROPOSAL FORM 6 pages

GENERAL CONDITIONS 41 pages

PREVAILING WAGES 1 page

DIVISION 1 – GENERAL REQUIREMENTS

Section 010000 – General Requirements 5 pages

Section 010099 – Surveying 2 pages

Section 012300 – Alternates 3 pages

Section 013300 – Submittal Procedures 4 pages

Section 013301 – Submittal Transmittal 1 page

Section 013501 – Inadvertent Discovery of Cultural Resources and Skeletal Remains 5 pages

Section 014000 – Quality Requirements 8 pages

Section 014100 – Regulatory Requirements 2 pages

Section 014200 – References 3 pages

Section 015000 – Temporary Facilities and Controls 5 pages

Section 015526 – Traffic Control 2 pages

Section 015639 – Temporary Tree and Plant Protection 7 pages

Section 015713 – Temporary Erosion Control 3 pages

Section 016000 – Product Requirements 3 pages

Section 017419 – Construction Waste Management and Disposal 1 page

Section 017700 – Closeout Procedures 6 pages

DIVISION 2 – EXISTING CONDITIONS

Section 024000 – Demolition 4 pages

DIVISION 3 – CONCRETE

**KOPACHUCK STATE PARK
DAY USE DEVELOPMENT**

Section 031000 – Concrete Forming	4 pages
Section 032000 – Concrete Reinforcing	5 pages
Section 033000 – Cast-In-Place Concrete	6 pages
Section 033713 – Pneumatically Applied Concrete	16 pages
Section 035400 – Cast Underlayment.....	5 pages

DIVISION 5 – METALS

Section 055000 – Metal Fabrications	4 pages
---	---------

DIVISION 6 – WOOD, PLASTICS, AND COMPOSITES

Section 060555 – Selective Tree Salvage	5 pages
Section 061000 – Rough Carpentry	5 pages
Section 061300 – Round Wood Poles	3 pages
Section 061500 – Heavy Timber Construction.....	3 pages
Section 061600 – Sheathing.....	3 pages
Section 061800 – Glued-Laminated Construction.....	6 pages
Section 062013 – Exterior Finish Carpentry.....	2 pages
Section 062023 – Interior Finish Carpentry.....	4 pages
Section 064116 – Plastic-Laminate-clad Architectural Cabinet	4 pages
Section 067300 – Composite Decking.....	5 pages

DIVISION 7 – THERMAL AND MOISTURE PROTECTION

Section 072100 – Insulation.....	5 pages
Section 072500 – Weather Barriers	5 pages
Section 074113 – Metal Roof Panels.....	5 pages
Section 074646 – Fiber-Cement Siding.....	3 pages
Section 076200 – Sheet Metal Flashing and Trim.....	4 pages
Section 079200 – Joint Sealers	7 pages

DIVISION 8 - OPENINGS

Section 081113 – Hollow Metal Doors and Frames	4 pages
Section 081416 – Flush Wood Doors	5 pages
Section 083113 – Access Doors and Frames	2 pages
Section 083313 – Coiling Counter Doors	2 pages
Section 083513 – Accordion Folding Doors.....	2 pages
Section 083613 – Sectional Doors	5 pages
Section 084313 – Aluminum Framed Storefront.....	7 pages
Section 085200 – Wood Windows	4 pages
Section 086200 – Unit Skylights	4 pages
Section 087100 – Door Hardware.....	11 pages
Section 088000 – Glazing.....	5 pages
Section 089100 – Louvers	4 pages
Section 089516 – Wall Vents	2 pages

DIVISION 9 - FINISHES

Section 092116 – Gypsum Board Assemblies.....	5 pages
---	---------

**KOPACHUCK STATE PARK
DAY USE DEVELOPMENT**

Section 093013 – Ceramic Tiling	5 pages
Section 095100 – Suspended Acoustical Ceilings	5 pages
Section 095440 – Manufactured Ceiling Planks	1 pages
Section 096500 – Resilient Flooring	6 pages
Section 096519 – Resilient Tile Flooring	3 pages
Section 097733 – Glass Fiber Reinforced Plastic Panels	3 pages
Section 099113 – Exterior Painting	7 pages
Section 099123 – Interior Painting	7 pages

DIVISION 10 – SPECIALTIES

Section 101101 – Visual Display Boards	2 pages
Section 101400 – Signs	3 pages
Section 101423 – Signage	3 pages
Section 102813 – Toilet Accessories	5 pages
Section 103100 – Manufactured Gas Fireplace	4 pages
Section 104400 – Fire Protection Specialties	2 pages
Section 105636 – Slatwall	2 pages

DIVISION 11 - EQUIPMENT

Section 112213 – Depository Safe	1 pages
Section 113013 – Residential Appliances	2 pages
Section 115213 – Projection Screens	2 pages

DIVISION 12 – FURNISHINGS

Section 122413 – Roller Window Shades	3 pages
Section 123600 – Stainless Steel Countertops	3 pages

DIVISION 22 - PLUMBING

Section 220500 – General Plumbing Requirements	11 pages
Section 220510 – Excavation & Backfill	5 pages
Section 220519 – Piping Specialties	2 pages
Section 220520 – Pipe & Pipe Fittings	4 pages
Section 220529 – Pipe Hangers & Supports	4 pages
Section 220530 – Sleeves & Seals	2 pages
Section 220548 – Piping Vibration & Seismic Control	2 pages
Section 220700 – Piping Insulation	5 pages
Section 221100 – Domestic Water Piping	5 pages
Section 221123 – Pumps	2 pages
Section 221300 – Soil Waste & Vent Piping	4 pages
Section 224000 – Plumbing Fixtures & Trim	6 pages

DIVISION 23 – HEATING, VENTILATING, AND AIR CONDITIONING (HVAC)

Section 230500 – General HVAC Requirements	10 pages
Section 230529 – HVAC Hangers & Supports	3 pages
Section 230548 – HVAC Vibration & Seismic Control	2 pages
Section 230593 – Air Balancing	4 pages

**KOPACHUCK STATE PARK
DAY USE DEVELOPMENT**

Section 230700 – HVAC Insulation	4 pages
Section 230900 – Control Systems (Buildings).....	5 pages
Section 231123 – Propane Gas Piping.....	2 pages
Section 233100 – Ductwork.....	4 pages
Section 233300 – Air Duct Accessories	2 pages
Section 233400 – Fans.....	4 pages
Section 233700 – Air Outlets & Inlets.....	4 pages
Section 237200 – Energy recovery Ventilators	3 pages
Section 237300 – HVAC Equipment.....	6 pages

DIVISION 26 - ELECTRICAL

Section 260500 – Common Work Results for Electrical.....	12 pages
Section 260519 – Low-Voltage Electrical Power Conductors and Cables.....	4 pages
Section 260526 – Grounding and Bonding for Electrical Systems.....	8 pages
Section 260533 – Raceways and Boxes for Electrical Systems	14 pages
Section 260540 – Electrical Site Work.....	5 pages
Section 260553 – Identification for Electrical Systems.....	8 pages
Section 260923 – Lighting Control Devices.....	12 pages
Section 262200 – Low Voltage Transformers	7 pages
Section 262416 – Panelboards.....	10 pages
Section 262816 – Enclosed Switches and Circuit Breakers	9 pages
Section 265100 – Interior Lighting.....	11 pages
Section 265600 – Exterior Lighting.....	11 pages

DIVISION 27 – COMMUNICATIONS

Section 270500 – Common Work Results for Communications.....	13 pages
Section 270526 – Grounding and Bonding for Communications Systems.....	9 pages
Section 270529 – Hangers and Supports for Communications Systems	4 pages
Section 270533 – Conduits and Backboxes for Communications Systems.....	4 pages
Section 271100 – Communications Equipment Room Fittings.....	7 pages

DIVISION 28 – ELECTRONIC SAFETY AND SECURITY

Section 282300 – Video Surveillance.....	13 pages
--	----------

DIVISION 31 - EARTHWORK

Section 310000 – Earthwork.....	8 pages
Section 311000 – Site Clearing.....	3 pages
Section 312000 – Earthwork (Utility Trenching)	6 pages

DIVISION 32 – EXTERIOR IMPROVEMENTS

Section 321216 – Asphalt Concrete Pavement and Pavement Marking.....	3 pages
Section 321313 – Cast-In-Place Concrete	13 pages
Section 321613 – Cast-in-Place Concrete Curb and Gutter.....	2 pages
Section 323915 – Site Furnishings	5 pages
Section 323916 – Playground Surfacing and Crushed Rock Paths.....	3 pages
Section 329113 – Soil Mixes & Placement	3 pages

**KOPACHUCK STATE PARK
DAY USE DEVELOPMENT**

Section 329200 – Seeding..... 5 pages
Section 329300 – Planting 9 pages

DIVISION 33 – UTILITIES

Section 331000 – Water Utility System..... 8 pages
Section 333000 – Sanitary Sewer 4 pages
Section 333200 – On Site Sewage System 5 pages
Section 334100 – Subdrainage..... 5 pages
Section 334400 – Storm Drain Utility 6 pages

END OF SECTION

**KOPACHUCK STATE PARK
DAY USE DEVELOPMENT**

INVITATION TO BID

1.1 DESCRIPTION OF WORK

- A. The project consists of work related to day use area development including removal of an existing restroom building, construction of a new Day Use Building and deck, Welcome Center building, wood decks, ramps, and stairs, wood amphitheater, concrete ADA accessible paths, picnic areas, play area elements, play tower structure, faux water feature, park entry gateway and sign, concrete walls, paved one-way parking lot with 98 stalls, vehicular gates, and school connector trail / pathway along the south side of 56th St NW. Work includes clearing, grading, concrete, asphalt, sanitary sewer, storm sewer, domestic water, electrical systems, CCTV system, and landscape planting.

1.2 LOCATION OF PROJECT

- A. The project is located at Kopachuck State Park, 10712 56th ST NW, Gig Harbor, WA 98335. South of the city of Gig Harbor in Pierce County, Washington on the east side of Henderson Bay.

1.3 TECHNICAL QUESTIONS

- A. Direct project questions to Brian Yearout, Project Representative at (360) 725-9763, brian.yearout@parks.wa.gov. 1111 Israel RD SW, Tumwater, WA 98501, FAX (360) 664-0312.

1.4 PRE-BID PROJECT SITE TOUR

DATE:	April 11, 2024
TIME:	10 AM
LOCATION:	Kopachuck State Park – Main Day Use Parking Lot

1.5 BID OPENING

- A. Bid responses will only be accepted electronically via email/email attachment BidBox@parks.wa.gov. See Section 7.1 of the Instructions to Bidders for expanded details. Subject line shall read: “SW-C1811 [YOUR COMPANY NAME]” in Bids are due at 1:00 p.m., Thursday, April 25th, 2024.
- B. Bid result notification is made by e-mail within two (2) days of the bids due date. Bid results can be obtained on the State Parks webpage at www.parks.state.wa.us/contracts or through Builders Exchange of Washington at www.bxwa.com
- C. The Commission reserves the right to accept or reject all bids and to waive informalities. No bidder may withdraw their bid after the bid deadline, or before award of contract, unless award is delayed over thirty (30) days.

**KOPACHUCK STATE PARK
DAY USE DEVELOPMENT**

1.6 COVID 19

- A. COVID-19 Refer to the Department of Labor & Industries website for requirements regarding any safety plans needed. [Novel Coronavirus Outbreak \(COVID-19\) Resources \(wa.gov\)](https://www.wa.gov/industry/employment/working-safely/working-safely-when-youre-a-contractor)

1.7 FOR INFORMATION ON:

- A. Reciprocal Preference, see Instructions to Bidders 2.1 Reciprocal Preference for Resident Contractors.
- B. Apprenticeship Requirements, For projects estimated at or over \$1,000,000, Apprenticeship Participation, Mandatory 15 percent apprentice labor, see Instructions to Bidders 4.1B Apprenticeship Participation.
- C. MWBE goals, see Instructions To Bidders 3.1 Minority And Women's Business Enterprise (MWBE) Utilization
- D. Modification of Bid, see Instructions to Bidders 7.1 Modification of Bid.
- E. Bid Security, see Instructions to Bidders 10.1 Bid Bond. No particular bid bond form is required.

1.8 ACCESSIBILITY

- A. Sites may not be fully accessible to people with disabilities. Please contact the Project Representative at least five (5) days prior to scheduled pre-bid tour if special accommodations are required for your attendance.

END

OF

SECTION

**WASHINGTON STATE PARK AND RECREATION COMMISSION
PUBLIC WORKS PROJECT**

1.1 BIDDER DEFINED

- A. A "*Bidder*" is an entity or person who submits a bid proposal for the work described in the contract documents.
- B. The Bidder must be registered by the Washington State Department of Labor and Industries in accordance with RCW 18.27.020. Insert the contractor registration number, expiration date, Uniform Business Identifier (UBI) number, and federal tax identification number on the Bid Proposal Form in the applicable spaces.

2.1 RECIPROCAL PREFERENCE FOR RESIDENT CONTRACTORS

- A. In accordance with RCW 39.04.380 the State of Washington is enforcing a Reciprocal Preference for Resident Contractors. Any public works bid received from a nonresident contractor from a state that provides an in-state percentage bidding preference, a comparable percentage disadvantage must be applied to the bid of that nonresident contractor.

A nonresident contractor from a state that provides a percentage bid preference means a contractor that:

- a) is from a state that provides a percentage bid preference to its resident contractors bidding on public works contracts.
- b) at the time of bidding on a public works project, does not have a physical office located in Washington.

The state of residence for a nonresident contractor is the state in which the contractor was incorporated or, if not a corporation, the state where the contractor's business entity was formed, and for an individual, the individual's state of residence.

All nonresident contractors will be evaluated for out of state bidder preference. If the state of the nonresident contractor provides an in-state contractor preference, a comparable percentage disadvantage will be applied to their bid prior to contract award.

This section does not apply to public works procured pursuant to RCW 39.04.155, 39.04.280, or any other procurement exempt from competitive bidding.

- B. A Comparable Percentage Disadvantage (CPD) will be applied to the bid of that nonresident contractor. The CPD is the in-state contractor percent advantage provided by the contractor's home state. For the purpose of determining the successful bidder, multiply the Nonresident Contractor bid amount by the CPD. The "bid amount" is be the total of the base bid and all accepted alternate bid items. The CPD is added to the Nonresident Contractor bid amount which equates to the Nonresident Disadvantage Total. The Nonresident Disadvantage Total is compared to the Washington contractor bid amounts. The bidder with the lowest total is the successful bidder.

See example below.

EXAMPLE: Alaska Nonresident Contractor Bid Amount \$100,000
Multiplied by the Alaska CPD x 0.05
Alaska CPD Total \$ 5,000
Alaska Nonresident Contractor Bid Amount \$100,000
Alaska CPD Total \$ 5,000
Nonresident Disadvantage Total \$105,000*

**WASHINGTON STATE PARK AND RECREATION COMMISSION
PUBLIC WORKS PROJECT**

* Note – If the Nonresident Disadvantage Total is lower than all other Washington contractor bid amounts, the Alaska Nonresident Contractor is the successful bidder and will be awarded a contract for the bid amount of \$100,000.

If the Nonresident Disadvantage Total is higher than a Washington contractor bid amount, the successful Washington bidder will be awarded a contract for the bid amount.

3.1 MINORITY AND WOMEN'S BUSINESS ENTERPRISE (MWBE) UTILIZATION

In accordance with the legislative findings and policies set forth in Chapter 39.19 RCW, the State of Washington encourages participation in contracts by MWBE firms certified by the Office of Minority and Women's Business Enterprises (OMWBE). Participation may be either on a direct basis in response to this solicitation/invitation or as a subcontractor to a Bidder. However, unless required by federal statutes, regulations, grants, or contract terms referenced in the contract documents, no preference will be included in the evaluation of bids, no minimum level of MWBE participation is required as a condition for receiving an award, and bids will not be rejected or considered non-responsive on that basis. Any affirmative action requirements set forth in federal regulations or statutes included or referenced in the contract documents will apply.

4.1 REQUIREMENTS FOR PROJECTS ESTIMATED AT \$1,000,000 OR MORE

A. **Any bid that is expected to cost one million dollars (\$1,000,000.00) or more** for the construction, alteration, or repair of any public building or public work of the state shall require each Bidder to submit **as part of the bid** the names of subcontractors with whom the Bidder, if awarded the contract, will subcontract for performance of the work of heating, ventilation and air conditioning, plumbing, and electrical, structural steel installation, rebar installation or to name itself for the work. The Bidder shall not list more than one subcontractor for each category of work identified, unless subcontractors vary with bid alternates, in which case the Bidder must indicate which subcontractor will be used for which alternate. **Failure of the Bidder to submit as part of the bid, the names of such subcontractors, or to name itself to perform such work, or the naming of two or more subcontractors to perform the same work, shall render the bid as non-responsive and therefore void.**

B. APPRENTICESHIP PARTICIPATION

In projects estimated to cost One Million Dollars or more, be aware that the following requirements will be part of the resulting contract.

In accordance with [RCW 39.04.320](#) (Apprenticeship Training Programs), for all public works estimated by the WSPRC Project Engineer to cost **one million dollars or more**, the state of Washington requires no less than **15% of the labor hours be performed by apprentices**. A contractor or subcontractor may not be required to exceed the 15% requirement. The bid advertisement and Bid Proposal Form shall establish a minimum required percentage of apprentice labor hours compared to the total labor hours.

1. **Incentives** - The Contractor who meets or exceeds this utilization requirement on eligible contracts, will be awarded a monetary incentive described in the Apprentice Utilization Requirements section of the Bid Form.
2. **Penalties** - The Contractor who fails to meet the utilization requirement and fails to demonstrate a Good Faith Effort, as outlined below, is subject to penalties described in the Apprentice Utilization Requirements section of the contract Bid Form. Contractor will receive an invoice payable to the Owner within 30 days.

**WASHINGTON STATE PARK AND RECREATION COMMISSION
PUBLIC WORKS PROJECT**

3. **Cost Value** - The expected cost value associated with meeting the goal is included in the Base Bid as described on the Bid Form.
 4. **Utilization Plan** - The Contractor shall provide an Apprentice Utilization Plan (Plan) demonstrating how and when they intend to achieve the Apprenticeship Utilization Requirement. The Plan shall have enough information to track the Contractor's progress in meeting the utilization requirement. The Contractor shall submit the Plan on the Apprentice Utilization Plan template within 10 business days of Notice to Proceed of the contract and prior to submitting the first invoice. The Contractor shall provide an updated Plan during the course of construction when there are significant changes to the Plan which may affect their ability to meet the requirement.
 - a) The Plan shall be uploaded to the Department of Labor & Industries' (L&I): ***Prevailing Wage Intents and Affidavit (PWIA) system on L&I's website.***
 - b) The Plan is not submitted for approval.
 - c) It is expected that the Contractor will actively seek out opportunities to meet the Apprentice Utilization Requirement during construction even if the Plan indicates a shortfall in meeting the requirement.
 - d) If the Plan indicates that the Contractor will not attain the Apprentice Utilization Requirement, then Contractor must submit "Good Faith Effort" (GFE) documentation with their Plan to L&I's PWIA system.
- C. APPRENTICESHIP - GOOD FAITH EFFORT (GFE)
1. **Good Faith Effort (GFE)** documentation shall describe in detail why the Contractor is not or was not able to attain the Apprentice Utilization Requirement.
 - a) Contractors may submit Good Faith Effort (GFE) documentation at any time during the construction.
 - b) All GFE documentation must be submitted no later than 30 days before substantial completion.
 - c) Good Faith Effort (GFE) documentation must be in signed letter format uploaded to the PWIA system and include:
 1. The contract number, title and the apprentice utilization requirements,
 2. The amount of apprentice labor hours the contract can or did attain along with the percentage of labor hours,
 3. Contractors may receive a GFE credit for graduated Apprentice hours through the end of the calendar year for all projects worked on as long as the Apprentice remains continuously employed with the same Contractor they were working for when they graduated. If an Apprentice graduates during employment on a project of significant duration, they may be counted towards a GFE credit for up to one year after their graduation or until the end of the project (whichever comes first). Determination of whether or not Contract requirements were met in good faith will be made by subtracting the hours from the journeyman total reported hours for the project and adding them to the apprentice hour total. If the new utilization percentage meets the Contract requirement, the Contractor will be reported as meeting the requirement in good faith,
 4. Anticipated or actual shortfall (in apprentice labor hours and percentage) and the reason(s) for not attaining the required apprentice labor hours,
 5. Information from one or more of the following areas:
 - (a) Names of any State-Approved Apprentice Training Programs contacted with the name(s) of person(s) contacted and dates of contacts, and a copy of each response from the Training Program(s),

**WASHINGTON STATE PARK AND RECREATION COMMISSION
PUBLIC WORKS PROJECT**

- (b) Reference Contract Specifications or documents that affected the Contractor's ability to attain apprentice utilization,
 - (c) Discuss efforts the Contractor has taken to require Subcontractors to solicit and employ apprentices,
6. Backup documentation to the letter consisting of the following:
Letters, emails, phone logs including names dates and outcomes, posters, photos, payrolls, time cards, schedules, copies or references to other contract specifications or documents.

Additional Resource Information

- (a) For questions regarding how to complete the Apprentice Utilization Plan template or Good Faith Effort documentation, please contact the Project Manager listed in the Bid Advertisement.
- (b) Step-by-step instructions on how to access and navigate the L&I's PWIA system, including uploading required documents can be found on the L&I website.
- (c) Additional information about apprentice utilization on Public Works Project can be found on the L&I website.

5.1 EXAMINATION OF THE WORK SITE AND BIDDING DOCUMENTS

- A. Bidder acknowledges that it has taken steps necessary to ascertain the nature and location of the work, and that it has investigated and satisfied itself as to the general and local conditions which can affect the work or its cost, including but not limited to (1) conditions bearing upon transportation, disposal, handling, and storage of materials; (2) the availability of labor, water, electric power, and road; (3) uncertainties of weather, river stages, tides, or similar physical conditions at the site; (4) the conformation and conditions of the ground; and (5) the character of equipment and facilities needed preliminary to and during the work. The bidder also acknowledges that it has satisfied itself as to character, quality, and quantity of surface and subsurface materials or obstacles to be encountered insofar as this information is reasonably ascertainable from an inspection of the site, including exploratory work done by the Owner, as well as from the drawings and specifications made a part of this contract. Any failure of the Bidder to take the actions described and acknowledged in this paragraph will not relieve the Bidder from responsibility for estimating properly the difficulty and cost of successfully performing the work.
- B. No statement by any officer, agent, or employee of the Agency pertaining to the physical conditions of the site of the work will be binding on the Agency other than those statements issued in the contract documents.
- C. Bidders shall promptly notify the Agency of ambiguities, inconsistencies, or errors, if any, which they may discover upon examination of the Bidding Documents or of the site and local conditions.
- D. Interpretations and Clarifications
 - 1) Every request for interpretation or clarification should be submitted to the project representative as listed in the Invitation to Bid. If a Bidder does not have on-line capability, then submit in writing, addressed to the project representative at the address as listed in the Invitation to Bid. To be given consideration the request must be received seven (7) working days prior to the date fixed for the opening of the bids.

**WASHINGTON STATE PARK AND RECREATION COMMISSION
PUBLIC WORKS PROJECT**

- 2) The Agency's responses, if there are any, which do not change the Scope of Work described in the contract documents may be mailed, delivered, faxed, or by other electronic means, to all planholders of record, at the respective address furnished for such purposes, prior to the date fixed for the receipt of bids. Such letters of clarification shall not be considered part of the contract documents and therefore need not be acknowledged by the Bidders as part of the Bid Form. The Agency will determine at its sole discretion whether or not any clarification or interpretation changes the Scope of Work and should be included in the Contract Documents.
- 3) Clarifications, interpretations, or supplemental instructions which do change the Scope of Work and or schedule described in the contract documents, will be issued only in the form of written ADDENDA.
- 4) Oral interpretations or clarifications will be without legal effect.

E. Substitutions

- 1) The product, equipment, materials, or methods described or noted within the Bidding Documents, whether currently available or not, are to establish a standard of quality, function, appearance and dimension. A proposed substitution shall have equal attributes in all respects.
- 2) No substitution will be considered unless a written request for approval is submitted by the Contractor, after Award, in accordance with the applicable provisions of Section 012500 of the specifications. If no Section 012500 is available, then see section 016000 Product Requirements, sub-section 1.5. Each such request shall describe the proposed substitution in its entirety including name of the material or equipment, drawings, catalog cuts, performance or test data and all other information required for an evaluation. The submittal shall also include a statement noting all changes required in adjoining, dependent or other interrelated work necessitated by the incorporation of the proposed substitute. The Bidder shall bear the burden of proof of merit of the proposed substitution. The Project Representative's decision of approval or disapproval of a proposed substitution shall be final.

6.1 BID PROPOSAL

- A. The Bidder shall submit its bid on the forms included with these instructions. All blank spaces in the Bid Proposal Form must be properly filled in. If the bid is made by a partnership or co-partnership, it must be so stated and it must be signed in the firm's name, followed by the written signature of the signing partner. If the bid is made by a corporation, it must be signed in the name of the corporation, followed by the written signature of the officer signing, and the printed or typewritten designation of their office within the corporation. The full and complete address of the Bidder must be typed or printed on the bid in the spaces provided. The bid must be a scan of the original bid, complete with an original signature (pen to paper).
- B. Except as otherwise provided in these instructions, bid proposals that are incomplete, or that are conditioned in any way, or that contain erasures, alterations, or items not called for in the contract documents, or that do not conform to the call for bids, may be rejected as non-responsive at the discretion of the Agency unless the law requires that the omission be deemed non-responsive, in which case the bid will be rejected as non-responsive. Only the amounts and information asked for on the Bid Proposal Form and the plans and

**WASHINGTON STATE PARK AND RECREATION COMMISSION
PUBLIC WORKS PROJECT**

specifications furnished will be considered as the bid. Bid amounts include all taxes imposed by law, **except** for Washington Sales Tax unless noted otherwise.

- C. Each Bidder shall bid upon the work exactly as specified and as provided in the Bid Proposal Form. The Bidder shall bid upon all alternates if alternates are indicated on the Bid Proposal Form. When bidding on alternates for which there is no charge, the Bidder shall write the words "no charge" in the space provided on the Bid Proposal Form.
- D. Bidders shall acknowledge receipt of any ADDENDA to the solicitation for bids on the Bid form.

7.1 SUBMISSION OF BID

- A. Bid responses will only be accepted electronically via email/email attachment BidBox@parks.wa.gov.
- B. Marking of The Bid Response (Email Subject Line):

Subject line should include the bid's identification number, "Bid" and Company name.

- Example email subject line: SWR-SW-C9999 Bid ACME Construction Inc.
- Example email subject line: NW-C9999 Bid John Smith Construction LLC
- Example email subject line: EW-C9999 Bid Sunshine Construction Corp.

- C. Signature (what is acceptable):

The purpose of a signature is to ensure a manifestation of asset by the signer and to legally bind the signer to the documents submitted.

In 2020 Washington State enacted law allowing for alternatives to hardcopy original wet-ink signatures. While the Bidder cannot force any process upon the Agency, the Agency can mandate and accept alternatives to an original wet-ink signature.

The Agency will accept a picture of an original wet-ink signature, such as a PDF scan. .JPG, TIFF-Group 4 (or similar technology). These three (3) technologies are known to work. The Bidder's use of other technology is at the Bidder's risk and peril. Bids or bid formats that the Agency cannot open and view shall be deemed non-responsive.

For clarity: Print out the competition document, review it, include any other required document(s) (such as the Bid Bond if required), complete where necessary, sign where indicated with a pen onto the paper, when you believe your bid response is ready to be submitted to the Agency, scan it as a PDF file, check the PDF file to make sure all pages are legible, then attach the file to your business email and send it to BidBox@parks.wa.gov.

It is the Agency's expectation that the Bidder's bid response email will contain a PDF attachment with all of the required documents scanned as a PDF, including any required signatures.

**WASHINGTON STATE PARK AND RECREATION COMMISSION
PUBLIC WORKS PROJECT**

7.2 Bid Clock:

After the bid opening (due date deadline), Agency staff will review the bids. The email's date and timestamp that is visible on the email, from the Agency's perspective, shall serve as the bid clock and it is this information that will be used to determine if the bid was timely.

CAUTION: Submit your bid response early as a safeguard against any technological slow-down or delays and/or malfunctions. Bids received after the deadline for any reason, no matter the cause, regardless of responsibility, will be rejected. When and whatever time the email comes in, the Contracts Specialist will reference the email's timestamp to determine responsiveness.

You are welcome to follow up with an email to contracts@parks.wa.gov and ask confirmation of receipt and the Contracts Specialist can send a reply to the sender of the bid response. However, our ability to respond is not instantaneous, not guaranteed, and works best if there's at least three (3) business days of time to respond.

8.1 MODIFICATION OF BID

A. Modifying And Supplementing Prior To Bid Opening:

Modifying: Modifying refers to a bid that has already been submitted to the Agency. Modifying means altering information already contained in the Bidder's bid response that has already been submitted to the Agency.

Supplementing: Supplementing refers to a bid that has already been submitted to the Agency. Supplementing means adding to the bid response for materials, documents, or information not already in the Bidder's bid response.

HOW: Bidder may modify or supplement its bid prior to the bid due date by sending a replacement bid by email to: BidBox@parks.wa.gov. In the body of the email clearly explain that this bid response is replacing an earlier one. Follow the example subject line.

Example email subject line: SWR-SW-C9999 Replacement Bid ACME Construction Inc.

Do not send in a piece of a bid response asking the Agency to link it up with the earlier bid response. Send in a full and complete replacement.

9.1 WITHDRAWAL OF BID

A. Withdrawal refers to a bid that has already been submitted to the Agency. A bid response may be withdrawn by a Bidder before the Bid Opening (due date deadline) for the bid. The FAILURE TO WITHDRAW a bid prior to the bid due date deadline exposes the Bidder to the possibility that the Agency will make a demand against the Bidders bid bond.

B. HOW: Bidder may withdraw its bid prior to the bid due date by sending an email to: BidBox@parks.wa.gov. In the body of the email clearly explain that the earlier bid submission is being withdrawn. Follow the example subject line.

Example email subject line: SWR-SW-C9999 Withdraw Bid ACME Construction Inc.

**WASHINGTON STATE PARK AND RECREATION COMMISSION
PUBLIC WORKS PROJECT**

10.1 REJECTION OF BID

- A. The Agency reserves the right to reject any or all bids and to waive informalities in connection with the bids.

11.1 BID BOND

- A. When the total bid amount is \$35,000 or less, a bid bond is not required. When the sum of the base bid plus all additive bid alternates is \$35,000.00 or less, bid security is not required.
- B. When the sum of the base bid plus all additive alternates is greater than \$35,000.00, a bid guarantee in the amount of 5% of the base bid amount is required. Failure of the Bidder to provide bid guarantee when required shall render the bid non-responsive.
- C. Acceptable forms of bid guarantee are: A bid bond. A copy of the bid bond must be included along with your bid response to the Agency. See also, Section 7.1 SUBMISSION OF BIDS – SECTION A.
- D. Should the successful Bidder fail to enter into a contract and furnish a satisfactory performance bond within 15 days after receiving properly prepared contract forms from the Agency, the bid bond may be forfeited as liquidated damages for advertisements and administration of bid procedures.
- E. Bid bonds must be held for the three low bids for 30 days or until a contract is executed with the successful Bidder. All other bid bonds will be returned to the Bidders within 15 days of the bid opening.

12.1 BID EVALUATION AND AWARD OF CONTRACT

- A. Award of contract will be made by the Agency based upon any combination of the base bid and alternates that, in the Agency's sole discretion, is in the Agency's best interest considering price, schedule, and other factors. The numbering of the alternates in the bid proposal bears no relationship to the order in which the alternates may be selected by the Agency. Additionally, the Agency reserves the right to negotiate base bid prices (including changes to the contract plans and specifications) with the low responsive, responsible Bidder to bring the final contract amount within the funds available.

- B. BID TABULATION AND ANNOUNCEMENT OF APPARENT LOW BID:

DON'T CALL STATE PARKS TO OBTAIN BID RESULTS.

The Agency does not guarantee when the Bid results will be released to the public. The bid results are usually released within three business days of the bid opening and often the same day. Bid results can be obtained by accessing the Washington State Parks webpage at www.parks.wa.gov/contracts (see "Construction Projects- Public works bid results"). The Bid Tabulation results may also be released through Builders Exchange of Washington at www.bxwa.com. But, Bidders are cautioned that the Washington State Parks website is the official release point for the Bid Tabulation for this competition.

The bid tabulation will identify all bids received by the Agency. Bids that were not rejected and not withdrawn prior to the bid opening will be ranked by base bid price. The first three lowest base bids will reflect detailed pricing information. The remaining Bidders will reflect only the base bid pricing. Bids that were rejected for any reason will reflect **Non-Responsive** in the bid tabulation but may include its total pricing.

**WASHINGTON STATE PARK AND RECREATION COMMISSION
PUBLIC WORKS PROJECT**

Release of the Bid Tabulation information that a Firm was identified as the apparent low base bid simply means that at this point in time the Agency believes the subject bid was the lowest cost responsive bid, but designation as the apparent low responsive bid is not a guarantee of a contract with the Agency. The Agency reserves the right to consider Alternate Bid Items in any combination. The Agency reserves the right to reevaluate the bid and determine whether the bid was responsive and responsible and successful as first thought. The Bidder identified as the apparent low responsive bid is cautioned not to commit funds, resources, and effort prior to receiving an actual executed contract. The Bidder identified as the apparent low responsive bid that commit funds, resources, and effort prior to a contract do so at its own risk and peril.

BID TABULATION & PROTEST: Within three (3) business days following the day of the release of the Bid Tabulation/Announcement of the Apparent Low bid (on the Washington State Parks website), the Bidder may file a Protest (Protest procedures are outlined in Section 13.1).

- C. **REJECTION LETTER & PROTEST:** No matter the phase of the evaluation, if the Agency determines that the bid is not responsive or the Bidder is not responsible, the Agency will reject the bid/bidder, and send the bidder a Rejection Letter explaining why the bid/bidder was rejected. Within three (3) business days following the day of the release of the Rejection Letter, the Bidder may file a Protest, provided it meets one of the three (3) protest grounds (Protest procedures are outlined in Section 13.1). The Rejection Letter will be sent by email/email attachment to the email address provided by the Bidder in the Bidder's bid response.
- D. The intent of the Agency is to award a contract to the low responsive, responsible bidder by considering the following:

Responsible - A Bidder must meet the following mandatory responsibility criteria under RCW 39.04.350 (1) to be considered a responsible Bidder and qualified to be awarded a public works project. The Bidder must:

1. At the time of bid submittal, have a certificate of registration in compliance with Chapter 18.27 RCW;
2. Have a current state Unified Business Identifier (UBI) number;
3. If applicable, have industrial insurance coverage for the Bidder's employees working in Washington as required in Title 51 RCW; an employment security department number as required in Title 50 RCW; and a state excise tax registration number as required in Title 82 RCW;
4. Not be disqualified from bidding on any public works contract under RCW 39.06.010 or 39.12.065(3);
5. If bidding on a public works project subject to the apprenticeship utilization requirements in RCW 39.04.320, not have been found out of compliance by the Washington State Apprenticeship and Training Council for working apprentices out of ratio, without appropriate supervision, or outside their approved work processes as outlined in their standards of apprenticeship under Chapter 49.04 RCW for the one-year period immediately preceding the date of the bid solicitation; and
6. Within the three-year period immediately preceding the bid solicitation, not have been determined by a final a binding citation and notice of assessment issued by the

**WASHINGTON STATE PARK AND RECREATION COMMISSION
PUBLIC WORKS PROJECT**

department of labor and industries or through a civil judgment entered by a court of limited or general jurisdiction to have willfully violated, as defined in RCW 49.48.082, any provision of Chapters 49.46, 49.48, or 49.52 RCW. By signing the Bid Proposal Form, the bidder verifies under penalty of perjury, pursuant to RCW 9A.72.085. that the bidder is in compliance with this subsection

7. Supplemental Responsibility Criteria: In addition to the mandatory Bidder responsibility, the Agency may adopt relevant supplemental criteria for determining Bidder responsibility applicable to a particular project which the Bidder must meet (RCW 39.04.350 (3)).
 - a. If applicable, the Agency shall consider an overall accounting of the attached supplemental criteria for determining Bidder responsibility "DIVISION 00 SUPPLEMENTAL RESPONSIBILITY CRITERIA".
 - b. At least seven (7) days prior to the bid submittal deadline, a potential Bidder may request that the Agency modify the supplemental responsibility criteria. The Agency will evaluate the information submitted by the potential Bidder and respond before the bid submittal deadline. If the evaluation results in a change of the criteria, the Agency will issue an ADDENDA to the bidding documents identifying the new criteria.
 - c. Upon the Agency's request, the apparent low Bidder must supply the requested responsibility information within two (2) business days of request by the Agency. Withholding information or failure to submit all the information requested within the time provided may render the bid non-responsive and the bid/Bidder may be rejected by Rejection Letter.

Responsive - A bid will be considered responsive if its electronic response meets the following requirements:

1. It is received at the proper time and place.
2. It meets the stated requirements of the Bid Proposal Form.
3. It meets the requirements as stated in section 6.1.A of the Instructions To Bidders.
4. It is submitted by a licensed/registered contractor within the state of Washington at the time of bid opening.
5. It is accompanied by a bid guarantee, if required.

If inconsistencies or errors are noted in the bid proposal prices, **prices shown in words have precedence over prices shown in figures**. The **unit and lump sum prices have precedence over their total amounts**; and the **total amounts have precedence over the total bid**.

The apparent low Bidder, for purpose of award, is the responsive and responsible Bidder offering the low aggregate amount for the base bid plus selected additive or deductive bid alternates and meeting all other bid submittal requirements.

13.1 **PROTEST PROCEDURES**

A. GENERAL:

This protest process is a courtesy provided by the Agency and it is not governed by Washington's Administrative Procedures Act (APA), RCW 34.05, nor does it confer any additional rights above and beyond what the Bidder already enjoys as a taxpayer. The purpose of this process is to allow the Agency to correct evaluation process errors and problems before a contract is executed.

Only a Bidder may file a protest regarding this competition.

**WASHINGTON STATE PARK AND RECREATION COMMISSION
PUBLIC WORKS PROJECT**

The Bidder must strictly adhere to the protest process as set forth herein, the failure of which may result in a summary determination that the protest is without merit without an opportunity to cure.

B. FORM AND CONTENT:

All protests must:

- Be in writing.
- The protest must state and clearly articulate the grounds for the protest with specific facts and complete statements of the action(s) being protested.
- A description of the relief or corrective action being requested should also be included.
- All protests shall be addressed to the Procurement Coordinator.

C. CONTENT LIMITATIONS:

The Agency does not currently mandate any page limitation. However, the protest must be clearly articulated, succinct, organized, logical, and professional.

The Agency will reject protests that:

- fail to state and clearly articulate at least one of the three GROUNDS;
- contain rants, attacks, and/or disparaging or abusive remarks;
- include multiple attachments or references (document dumping, document overload); or,
- appear to require the reader piece together voluminous amounts of material to decipher the argument being made.

D. SUBMISSION OF PROTEST:

- All protests must be submitted within (5) business days after the formal Rejection Letter is sent. For purposes of timing the day the Rejection Letter is sent to the Bidder shall not count.
- Bidders must send all protests to: contracts@parks.wa.gov. See also Subject Line.
- SUBJECT LINE: Must include the competition's Number Identifier and "PROTEST" in the subject line. Failure by the Bidder to include this information in the subject line may result in Bidder's protest not being timely recognized.

E. GROUNDS WHICH MAY BE PROTESTED:

- Conflict of Interest on the part of Agency staff.
- Errors in computing the score.
- Non-compliance with procedures described in the procurement document.

Protests will be rejected as without merit if they do not clearly and convincingly meet one of the GROUNDS above and/or seems to address issues such as:

- An evaluator's professional judgment on the quality of a response, or
- The Agency's assessment of its own and/or other agencies' needs or requirements, or,
- Issues, concerns, objections, or requests for changes that were or could have been addressed prior to the bids due date deadline.

**WASHINGTON STATE PARK AND RECREATION COMMISSION
PUBLIC WORKS PROJECT**

Protests that do not clearly and convincingly meet the requirements and standards described herein are without merit and may be rejected.

F. MANAGER ASSIGNMENT AND REVIEW:

Upon receipt of a protest that meets the requirements described herein, a protest review will be held by the Agency. The Agency will assign a Manager. The Manager is responsible for reviewing and investigating the Bidder's written protest and may meet with agency staff or the agency program that was involved in the competition. The Manager may consider the record and all reasonably available facts and will issue a protest determination in writing within fifteen (15) business days from receipt of the protest. If additional time is needed, the Manager will notify the protesting party of the need for additional time within 15 business days from receipt of the protest.

In the event a protest may affect the interest of another Bidder that submitted a response, the Agency may reach out to that Bidder, may provide an unedited copy of the protest to that Bidder, and may invite that Bidder to submit its views and any relevant information on the protest to the Manager.

G. PROTEST DETERMINATION AND FINDINGS AND DISSEMINATION:

The Manager's protest determination may:

- Find the protest lacking in merit and reject the protest;
- Find only technical or harmless errors in the Agency's acquisition process and determine the Agency to be in substantial compliance and reject the protest; OR
- Find merit in the protest and provide THE AGENCY options which may include:
 - Correcting the errors and re-evaluating all responses;
 - Canceling the competition and possibly for a new competition to take place; OR
 - Making other findings and determining other courses of action as appropriate.

If the Agency rejects the protest, the Agency will enter into a contract with the Apparent Successful Bidder no sooner than two business days after issuance of the protest determination by email to the protesting party at the email address indicated on the party's bid documents. For the purposes of timing, the date the protest determination is sent to the protesting party shall not count.

Dissemination: The Agency will disseminate the decision to all interested Bidders via email/email attachment to the email address provided by the Bidder in the Bidder's bid response.

H. AGENCY DECISION IS FINAL:

The Manager's protest determination constitutes the agency's final decision regarding the protest. If the protesting party disagrees with the protest determination, the Bidder may seek judicial relief in the Washington Superior Court for Thurston County within 2 business days of the issuance of the protest determination.

I. STRICT COMPLIANCE

Strict compliance with these protest procedures is essential in furtherance of the public interest. Any aggrieved party that fails to comply strictly with these protest procedures is deemed, by such failure, to have waived and relinquished forever any right or claim with respect to alleged irregularities in connection with the solicitation or award of the Contract. No

**WASHINGTON STATE PARK AND RECREATION COMMISSION
PUBLIC WORKS PROJECT**

person or party may pursue any judicial or administrative proceedings challenging the solicitation or award of this Contract, without first exhausting the administrative procedures specified herein.

J. REPRESENTATION

An aggrieved party may participate personally or, if a corporation or other artificial person, by a duly authorized representative. Whether or not participating in person, an aggrieved party may be represented, at the party's own expense, by counsel.

K. COMPUTATION OF TIME

In computing any period of time prescribed by this procedure, the day of the act or event from which the designated period of time begins to run is not included. The last day of the period is included. The term "business day" does not include Sunday, Saturday, or Washington State recognized holiday.

L. ACKNOWLEDGEMENT

By submitting a bid in response to this solicitation, the Bidder acknowledges that it has reviewed and acquainted itself with the bid protest procedures herein and agrees to be bound by such procedures as a condition of submitting a bid.

14.1 EXECUTION OF CONTRACT

- A. The successful bidder will be required to execute the contract and furnish performance bond and insurance certificate satisfactory to the Agency within 15 days after receiving properly prepared contract documents from the Agency.

15.1 SUBCONTRACTOR PARTICIPATION MONITORING AND REPORTING

- A. Once a contract is awarded through the solicitation or proposal process, the awarded Prime Contractor is obligated to complete the vendor registration in Access Equity. Access Equity is a secure online vendor management system (B2GNow). Confidential information (Tax ID, etc.) will not be published. Prime Contractors that have previously registered with B2Gnow for any public entity, must verify the system has updated information. Contractors can access the system at <https://omwbe.diversitycompliance.com/> or through a direct link on the Office of Minority and Women's Business Enterprises (OMWBE) website at: <https://omwbe.wa.gov/>.
- B. Each month during the contract, the Prime Contractor will report payments to ALL Subcontractors through the Access Equity system. This monthly reporting information includes total payment in dollars made to the Subcontractor, payment dates, and any additional information required to verify payment to Subcontractors. The Prime Contractor will enter this payment information into the Access Equity system, and the Subcontractors will verify this payment information in the system. Online training is available through the Access Equity/B2Gnow system. This requirement applies to both Prime Contractors and Subcontractors.

END OF INSTRUCTIONS TO BIDDERS

/ / / / /

Hazardous Materials Survey Report

Kopachuck State Park Day Use Comfort Station Replacement

10712 56th Street Northwest
Gig Harbor, WA 98335

Prepared for:

Washington State Parks and Recreation Commission
11838 Tilley Road
Olympia, WA 98512

February 10, 2021
PBS Project No. 40525.060



214 EAST GALER STREET
SUITE 300
SEATTLE, WA 98102
206.233.9639 MAIN
866.727.0140 FAX
PBSUSA.COM

TABLE OF CONTENTS

1	INTRODUCTION	1
1.1	Project Background.....	1
1.2	Building Description	1
1.3	Survey Process	1
2	FINDINGS.....	2
2.1	Asbestos-Containing Materials (ACMs).....	2
2.2	Lead-Containing Paint (LCP)	2
2.3	Mercury-Containing Components.....	2
2.4	PCB-Containing Components.....	2
3	RECOMMENDATIONS.....	2
3.1	Asbestos-Containing Materials (ACMs).....	2
3.2	Lead-Containing Paint (LCP)	3
3.3	Mercury-Containing Components.....	3

APPENDICES

APPENDIX A: PLM Bulk Sampling Information

PLM Bulk Sample Inventory
PLM Bulk Sample Laboratory Data Sheets
PLM Bulk Sample Chain of Custody Documentation

APPENDIX B: AA Lead Paint Chip Sampling Information

AA Lead Paint Chip Sample Inventory
AA Lead Paint Chip Laboratory Data Sheets
AA Lead Paint Chip Chain of Custody Documentation

APPENDIX C: Certifications

1 INTRODUCTION

1.1 Project Background

PBS Engineering and Environmental, Inc. (PBS) performed a limited hazardous materials survey of the Kopachuck State Park Day Use Comfort Station located in Kopachuck State Park at 10712 56th Street Northwest in Gig Harbor, Washington. The intent of this investigation is to ensure that Washington State Parks & Recreation Commission is in compliance with applicable regulatory requirements that a "good faith inspection" for ACMs be performed prior to demolition.

At the request of the Washington State Parks and Recreation Commission (WSPR), all accessible areas of the building within the scope of work were inspected for the presence of Asbestos-Containing Materials (ACMs), Lead-Containing Paint (LCP), PCB-containing light ballasts, and mercury-containing fluorescent light tubes.

1.2 Building Description

The Day Use Comfort Station is a single-story wood structure that includes two restrooms and a custodial closet/pipe chase. Interior finishes include bare concrete floors and wood paneled walls and ceilings. The exterior features wood siding, wood-framed plexiglass windows, and a metal roof.

1.3 Survey Process

Accessible areas included in the project scope were inspected by AHERA-Certified Building Inspector Kaitlin Soukup (Cert. #179143, exp. 10/14/2021) on February 1, 2021. PBS endeavored to inspect all accessible areas within the scope of work. Inaccessible areas consist of those requiring fall protection or confined space entry protocol.

When observed, suspect materials were sampled. All samples were assigned a unique identification number and transmitted for analysis to Seattle Asbestos Test (NVLAP #201057-0) under chain-of-custody protocols. Samples were analyzed according to EPA Method 600R-93/116 using Polarized Light Microscopy (PLM), which has a reliable limit of quantification of 1% asbestos by volume. Information regarding the type and location of sampled materials can be found on the attached PLM Sample Inventory.

Suspect ACMs may exist in inaccessible areas. PBS endeavored to determine the presence and estimate the condition of suspect materials in all accessible areas. While PBS has endeavored to identify the ACM that may be found in concealed locations, additional unidentified ACM may exist.

2 FINDINGS

2.1 Asbestos-Containing Materials (ACMs)

- None of the materials sampled were found to contain asbestos.

The following materials were sampled and found to contain **no asbestos**:

- Yellow mastic associated with fiberglass reinforced plastic wall panels – Men's Restroom
- Silver coating and black mastic on pipe – Pipe Chase

Refer to Appendix A for a complete listing of PLM bulk sampling and associated laboratory analysis.

2.2 Lead-Containing Paint (LCP)

Six (6) representative painted coatings were sampled for lead content during this survey. The samples were assigned a unique identification number and transmitted to NVL Laboratories, Inc. (AIHA IH #101861) in Seattle, Washington under chain-of-custody protocols for analysis using Flame Atomic Absorption.

- Detectible concentrations of lead were identified in five (5) of the samples collected at concentrations ranging from 0.02% to 0.13%.

Refer to Appendix B for locations and results of paint samples.

2.3 Mercury-Containing Components

All fluorescent light tubes are presumed to contain mercury. PBS quantified the fluorescent tubes that will be impacted by the project for the purpose of mercury vapor recovery prior to demolition activities.

- Approximately four (4) four-foot fluorescent light tubes and one compact fluorescent light were identified as part of this survey.

2.4 PCB-Containing Components

PBS inspected representative fluorescent light fixture ballasts that are to be removed to facilitate the planned demolition. PBS did not find any PCB-containing light fixture ballasts.

3 RECOMMENDATIONS

3.1 Asbestos-Containing Materials (ACMs)

PBS did not identify any ACMs as part of this investigation.

The possibility exists that suspect ACM may be present in equipment, wall and ceiling cavities, and in select areas included in the scope of renovations. These may include, but are not limited to pipe insulation, interior building components, and construction adhesives and wall mastics. In the event that suspect ACM is encountered during construction, contractors should stop work immediately and inform the owner promptly for confirmation testing. All untested materials should be presumed asbestos-containing or tested for asbestos content prior to impact.

3.2 Lead-Containing Paint (LCP)

Representative paint coatings were found to contain detectable lead. Paint coatings may exist in inaccessible areas of the building or in secondary coatings on building components. Any previously unidentified painted coatings should be considered lead containing until sampled and proven otherwise.

Impact of paint with detectable concentrations of lead requires construction activities to be performed in accordance with the State of Washington Department of Labor and Industries regulation for Lead in Construction (WAC 296-155-176).

3.3 Mercury-Containing Components

PBS recommends that all fluorescent lamps be carefully handled and recycled/disposed of in accordance with the contract documents and applicable regulations during demolition activities. Breakage of lamps should be avoided to prevent potential exposures to mercury. Washington Department of Safety and Health requires specific training, handling, engineering controls and disposal practices when performing this work. All waste shall be handled in accordance with WAC 173-303.

Report prepared by:

Report reviewed by:

Kaitlin Soukup
AHERA Building Inspector
Cert. # 179143, Exp. 10/14/2021

Tim Ogden
Principal/ Sr. Project Manager,
AHERA Building Inspector
Cert. #IR-20-2008A, Exp. 4/1/2021

APPENDIX A

PLM Asbestos Bulk Sampling Information

PLM Asbestos Bulk Sample Inventory

PLM Asbestos Bulk Sample Laboratory Data Sheets

PLM Asbestos Bulk Sample Chain of Custody

**Kopachuck State Park Day Use Comfort Station Replacement
Washington State Parks and Recreation**

**PBS Engineering + Environmental
PBS Project #40525.060**

PLM ASBESTOS SAMPLE INVENTORY

<u>PBS Sample #</u>	<u>Material Type</u>	<u>Sample Location</u>	<u>Lab Description</u>	<u>Lab Result</u>	<u>Lab</u>
40525.060 -01	Fiberglass reinforced plastic panel mastic	Men's restroom	Layer 1: Yellow mastic	NAD	SAT
40525.060 -02	Silver coating Black mastic	Pipe chase	Layer 1: Trace silver paint Layer 2: Trace black asphaltic material	NAD NAD	SAT

SEATTLE ASBESTOS TEST, LLC

Seattle Laboratory: 4500 9th Ave. NE, Suite 300, Seattle, WA 98105, Tel: 206.633.1111, Fax: 206.633.4747, NVLAP Lab Code: 201057-0

www.seattleasbestostest.com, admin@seattleasbestostest.com

Project Manager: Ms. Kaitlin Soukup, Ms. Michelle Dodson, Mr. Tim Ogden

Client: PBS Engineering and Environmental, Seattle

Address: 214 E Galer Street, Suite 300, Seattle, WA 98102

Tel: 206.766.7601

Date Analyzed: 2/2/2021

Client Job#: 40525.060

Project Location: Kopachuck Day Use Comfort Station

Laboratory batch#: 202109173

Samples Received: 2

Enclosed please find the test results for the bulk samples submitted to our laboratory for asbestos analysis. Analysis was performed using polarized light microscopy (PLM) in accordance with Test Method US EPA - 40 CFR Appendix E of Part 763, Interim Method of Determination of Asbestos in Bulk Insulation Samples and Test Method US EPA/600/R-93/116.

Percentages for this report are done by visual estimate and relate to the suggested acceptable error ranges by the method. Since variation in data increases as the quantity of asbestos decreases toward the limit of detection, the EPA recommends point counting for samples containing between <1% and 10% asbestos (NESHAP, 40 CFR Part 61). Statistically, point counting is a more accurate method. If you feel a point count might be beneficial, please feel free to call and request one.

The test results refer only to the samples or items submitted and tested. The accuracy with which these samples represent the actual materials is totally dependent on the acuity of the person who took the samples. This report must not be used by the client to claim product certification, approval, or endorsement by Seattle Asbestos Test, LLC, NVLAP, NIST, or any agency of the Federal government. The test report or calibration certificate shall not be reproduced except in full, without written approval of the laboratory.

This report is highly confidential and will not be released without your consent. Samples are archived for 30 days after the analysis, and disposed of as hazardous waste thereafter.

Thank you for using our service and let us know if we can further assist you.

Sincerely



Steve (Fanyao) Zhang
President

SEATTLE ASBESTOS TEST

Seattle Laboratory: 4500 9th Ave. NE, Suite 300, Seattle, WA 98105, Tel: 206.633.1111, Fax: 206.633.4747, NVLAP Lab Code: 201057-0

Disclaimer: This report must not be used by the client to claim product certification, approval, or endorsement by Seattle Asbestos Test, LLC, NVLAP, NIST, or any agency of the Federal government.

ANALYTICAL LABORATORY REPORT PLM by Method EPA/600/R-93/116

Attn: Ms. Kaitlin Soukup,
Ms. Michelle
Dodson, Mr. Tim
Ogden

Client: PBS Engineering and
Environmental, Seattle

Address: 214 E Galer Street, Suite 300, Seattle, WA 98102

Job#: 40525.060

Batch#: 202109173

Date Received: 2/2/2021

Samples Rec'd: 2

Date Analyzed: 2/2/2021

Samples Analyzed: 2

Project Loc.: Kopachuck Day Use Comfort
Station

Analyzed by:  Carolyn Yoo

Reviewed by:  Steve (Fanyao) Zhang, President

Lab ID	Client Sample ID	Layer	Description	%	Asbestos Fibers	Non-fibrous Components	%	Non-asbestos Fibers
1	40525.060-01	1	Yellow mastic		None detected	Mastic/binder	2	Cellulose
2	40525.060-02	1	Trace silver paint		None detected	Filler, Paint	2	Cellulose
		2	Trace black asphaltic material		None detected	Asphalt/binder	2	Cellulose

APPENDIX B

AA Lead Paint Chip Sampling Information

AA Lead Paint Chip Bulk Sample Inventory

AA Lead Paint Chip Sample Laboratory Data Sheets

AA Lead Paint Chip Sample Chain of Custody

AA LEAD PAINT CHIP SAMPLE INVENTORY

<u>PBS Sample #</u>	<u>Paint Color / Component or Substrate</u>	<u>Sample Location</u>	<u>Results (ppm)</u>	<u>Results (%)</u>	<u>Lab</u>
40525.060 -Pb01	Yellow / wood / siding	South elevation	190.00	0.02	NVL
40525.060 -Pb02	Dark brown / wood / window frame	North elevation	1100.00	0.11	NVL
40525.060 -Pb03	Green / metal / door	Men's restroom	<42	<0.0042	NVL
40525.060 -Pb04	Green / wood panel / wall	Men's restroom, south wall	360.00	0.04	NVL
40525.060 -Pb05	White / wood panel / wall	Women's restroom, south wall	420.00	0.04	NVL
40525.060 -Pb06	Gray / concrete / foundation	Women's restroom	1300.00	0.13	NVL

February 2, 2021

Kaitlin Soukup

PBS Environmental - Seattle

214 E Galer St. Suite. 300

Seattle, WA 98102



NVL Batch # 2102026.00

RE: Total Metal Analysis
Method: EPA 7000B Lead by FAA <paint>
Item Code: FAA-02

Client Project: 40525.060

Location: Kopachuck Day Use Comfort Station

Dear Ms. Soukup,

NVL Labs received 6 sample(s) for the said project on 2/1/2021. Preparation of these samples was conducted following protocol outlined in EPA 3051/7000B , unless stated otherwise. Analysis of these samples was performed using analytical instruments in accordance with EPA 7000B Lead by FAA <paint>. The results are usually expressed in mg/Kg and percentage (%). Test results are not blank corrected.

For recent regulation updates pertaining to current regulatory levels or permissible exposure levels, please call your local regulatory agencies for more detail.

At NVL Labs all analyses are performed under strict guidelines of the Quality Assurance Program. This report is considered highly confidential and will not be released without your approval. Samples are archived after two weeks from the analysis date. Please feel free to contact us at 206-547-0100, in case you have any questions or concerns.

Sincerely,

A handwritten signature in black ink that reads "Yasuyuki Hida".

Yasuyuki Hida, Laboratory Analyst



Enc.: Sample results



Phone: 206 547.0100 | Fax: 206 634.1936 | Toll Free: 1.888.NVL.LABS (685.5227)
4708 Aurora Avenue North | Seattle, WA 98103-6516

Analysis Report

Total Lead (Pb)



Client: PBS Environmental - Seattle
Address: 214 E Galer St. Suite. 300
Seattle, WA 98102

Batch #: 2102026.00

Matrix: Paint
Method: EPA 3051/7000B
Client Project #: 40525.060
Date Received: 2/1/2021
Samples Received: 6
Samples Analyzed: 6

Attention: Ms. Kaitlin Soukup

Project Location: Kopachuck Day Use Comfort Station

Lab ID	Client Sample #	Sample Weight (g)	RL in mg/Kg	Results in mg/Kg	Results in percent
21020372	40525.060-Pb01	0.2064	48	190	0.019
21020373	40525.060-Pb02	0.1162	86	1100	0.11
21020374	40525.060-Pb03	0.2359	42	< 42	<0.0042
21020375	40525.060-Pb04	0.2252	44	360	0.036
21020376	40525.060-Pb05	0.2130	47	420	0.042
21020377	40525.060-Pb06	0.1945	51	1300	0.13

Sampled by: Client

Analyzed by: Shalini Patel

Reviewed by: Yasuyuki Hida

Date Analyzed: 02/02/2021

Date Issued: 02/02/2021

A handwritten signature in black ink that reads "Yasuyuki Hida".

Yasuyuki Hida, Laboratory Analyst

mg/ Kg =Milligrams per kilogram

Percent = Milligrams per kilogram / 10000

Note : Method QC results are acceptable unless stated otherwise.

Unless otherwise indicated, the condition of all samples was acceptable at time of receipt.

RL = Reporting Limit

'<' = Below the reporting Limit

Bench Run No: 2021-0202-05

FAA-02

LEAD LABORATORY SERVICES



Company PBS Environmental - Seattle	NVL Batch Number 2102026.00
Address 214 E Galer St. Suite. 300 Seattle, WA 98102	TAT 1 Day AH No
Project Manager Ms. Kaitlin Soukup	Rush TAT
Phone (206) 233-9639	Due Date 2/2/2021 Time 4:30 PM
	Email kaitlin.soukup@pbsusa.com
	Fax (866) 727-0140

Project Name/Number: 40525.060 **Project Location:** Kopachuck Day Use Comfort Station

Subcategory Flame AA (FAA)
Item Code FAA-02 EPA 7000B Lead by FAA <paint>

Total Number of Samples 6 **Rush Samples** _____

Lab ID	Sample ID	Description	A/R
1	21020372	40525.060-Pb01	A
2	21020373	40525.060-Pb02	A
3	21020374	40525.060-Pb03	A
4	21020375	40525.060-Pb04	A
5	21020376	40525.060-Pb05	A
6	21020377	40525.060-Pb06	A

	Print Name	Signature	Company	Date	Time
Sampled by	Client				
Relinquished by	Drop Box				

Office Use Only	Print Name	Signature	Company	Date	Time
Received by	Kelly AuVu		NVL	2/1/21	1630
Analyzed by	Shalini Patel		NVL	2/2/21	
Results Called by					
<input type="checkbox"/> Faxed <input type="checkbox"/> Emailed					

Special Instructions: _____

Date: 2/1/2021
 Time: 4:34 PM
 Entered By: Fatima Khan

APPENDIX C
Certifications

Certificate of Completion

This is to certify that

Kaitlin M. Soukup

has satisfactorily completed
4 hours of online refresher training as an
AHERA Building Inspector

to comply with the training requirements of
TSCA Title II, 40 CFR 763 (AHERA)

EPA Provider # 1085

179143
Certificate Number



Oct 14, 2020 Expires in 1 year.

Date(s) of Training

Exam Score: N/A
(if applicable)

A handwritten signature in black ink, appearing to read "AZ", written over a horizontal line.

Instructor: Andre Zwanenburg

ARGUS PACIFIC, INC / 21905 64th AVE W, SUITE 100 / MOUNTLAKE TERRACE, WASHINGTON 98043 / 206.285.3373 / ARGUSPACIFIC.COM

THIS IS TO CERTIFY THAT

TIM OGDEN

**HAS SUCCESSFULLY COMPLETED THE TRAINING COURSE
for
ASBESTOS INSPECTOR REFRESHER**

In accordance with TSCA Title II, Part 763, Subpart E, Appendix C of 40 CFR

Course Date: 04/01/2020
Course Location: Portland, OR
Certificate: IR-20-2008A

CCB #SRA0615 4-Hr Training

CCB #SRA0615 4-Hr Training

Expiration Date: 04/01/2021



For verification of the authenticity of this
certificate contact:
PBS Environmental
4412 SW Corbett Avenue
Portland, OR 97239
(503) 248-1939

A handwritten signature in black ink that reads "Andy Fridley".

Andy Fridley, Instructor

190224 Kopachuck St Park \ 20190224E001 F2 S-E 5-20.cdr

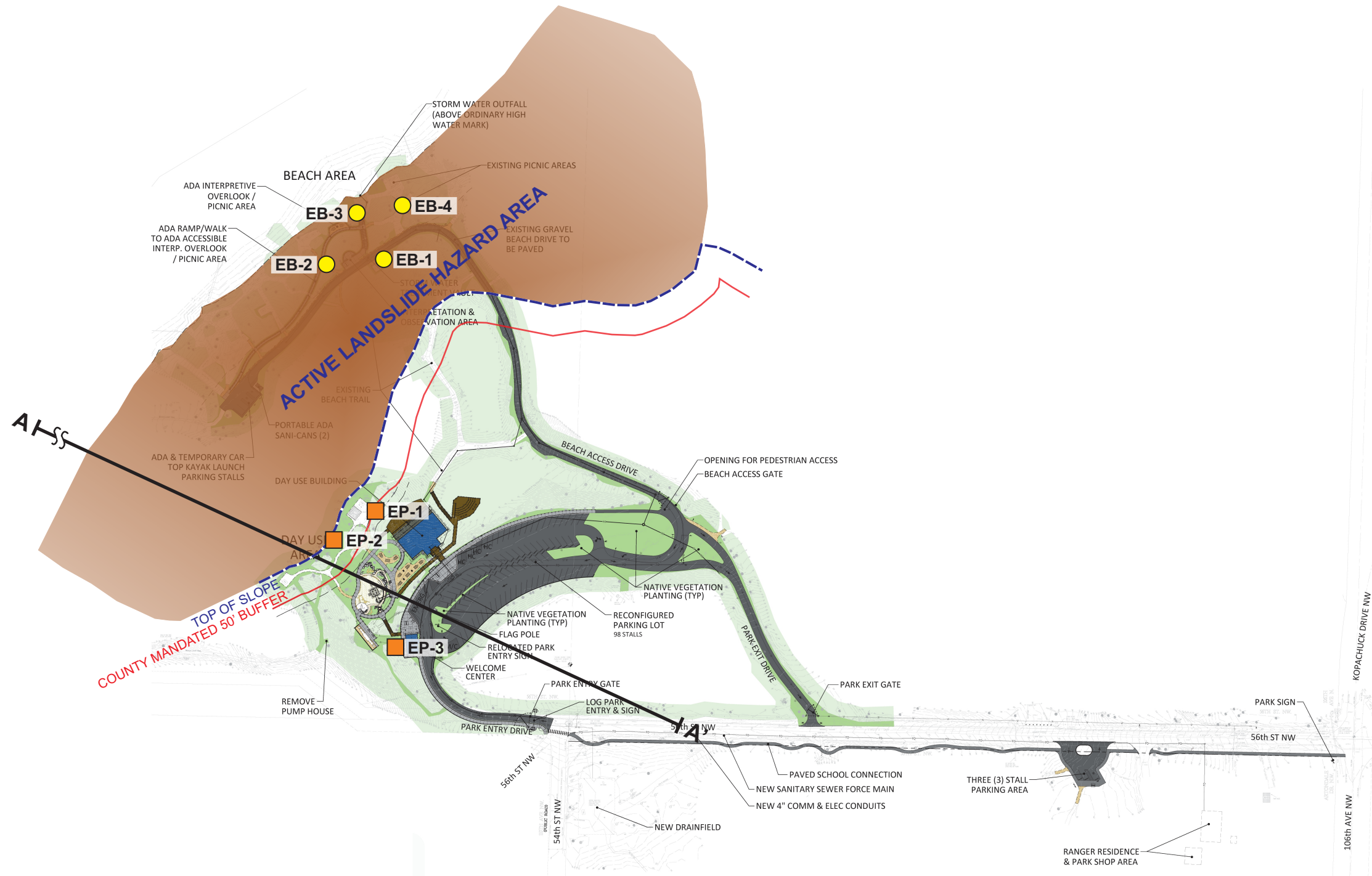

LEGEND:

- EB EXPLORATION BORING - 2019
- EP EXPLORATION PIT - 2018

CONTOUR INTERVAL = 1'

NOTE: LOCATION AND DISTANCES SHOWN ARE APPROXIMATE.

NOTES:

1. BASE MAP REFERENCE: BRUCE DEES AND ASSOCIATES, KOPACHUCK STATE PARK, PROPOSED SITE PLAN, 5/7/20

BLACK AND WHITE REPRODUCTION OF THIS COLOR ORIGINAL MAY REDUCE ITS EFFECTIVENESS AND LEAD TO INCORRECT INTERPRETATION.









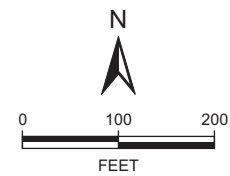

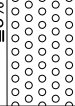

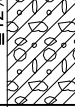
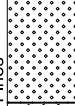
SITE AND EXPLORATION PLAN

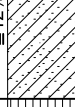
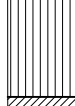
KOPACHUCK STATE PARK
PIERCE COUNTY, WASHINGTON

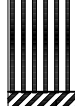



PROJ NO. 20190224E001	DATE: 5/20	FIGURE: 2
--------------------------	---------------	--------------



Coarse-Grained Soils - More than 50% (1) Retained on No. 200 Sieve		Terms Describing Relative Density and Consistency	
Coarse-Grained Soils - More than 50% (1) Retained on No. 200 Sieve Sands - 50% (1) or More of Coarse Fraction Passes No. 4 Sieve Gravel - More than 50% (1) of Coarse Fraction Retained on No. 4 Sieve		GW	Well-graded gravel and gravel with sand, little to no fines
		GP	Poorly-graded gravel and gravel with sand, little to no fines
		GM	Silty gravel and silty gravel with sand
		GC	Clayey gravel and clayey gravel with sand
		SW	Well-graded sand and sand with gravel, little to no fines
		SP	Poorly-graded sand and sand with gravel, little to no fines
Fine-Grained Soils - 50% (1) or More Passes No. 200 Sieve Silts and Clays Liquid Limit Less than 50 Silts and Clays Liquid Limit 50 or More		SM	Silty sand and silty sand with gravel
		SC	Clayey sand and clayey sand with gravel
		ML	Silt, sandy silt, gravelly silt, silt with sand or gravel
		CL	Clay of low to medium plasticity; silty, sandy, or gravelly clay, lean clay
		OL	Organic clay or silt of low plasticity
		MH	Elastic silt, clayey silt, silt with micaceous or diatomaceous fine sand or silt
Highly Organic Soils		CH	Clay of high plasticity, sandy or gravelly clay, fat clay with sand or gravel
		OH	Organic clay or silt of medium to high plasticity
		PT	Peat, muck and other highly organic soils

Component Definitions	
Descriptive Term	Size Range and Sieve Number
Boulders	Larger than 12"
Cobbles	3" to 12"
Gravel	3" to No. 4 (4.75 mm)
Coarse Gravel	3" to 3/4"
Fine Gravel	3/4" to No. 4 (4.75 mm)
Sand	No. 4 (4.75 mm) to No. 200 (0.075 mm)
Coarse Sand	No. 4 (4.75 mm) to No. 10 (2.00 mm)
Medium Sand	No. 10 (2.00 mm) to No. 40 (0.425 mm)
Fine Sand	No. 40 (0.425 mm) to No. 200 (0.075 mm)
Silt and Clay	Smaller than No. 200 (0.075 mm)

(3) Estimated Percentage		Moisture Content
Component	Percentage by Weight	
Trace	<5	Dry - Absence of moisture, dusty, dry to the touch Slightly Moist - Perceptible moisture Moist - Damp but no visible water Very Moist - Water visible but not free draining Wet - Visible free water, usually from below water table
Some	5 to <12	
Modifier (silty, sandy, gravelly)	12 to <30	
Very modifier (silty, sandy, gravelly)	30 to <50	

Symbols	
Sampler Type	Description
	2.0" OD Split-Spoon Sampler (SPT)
	3.0" OD Split-Spoon Ring Sampler
	3.0" OD Thin-Wall Tube Sampler (including Shelby tube)
	Grab Sample
	Portion not recovered

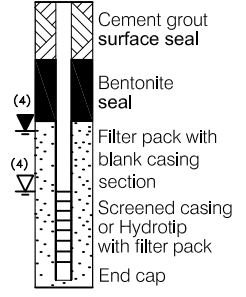
	(4) Depth of groundwater ▼ ATD = At time of drilling ▽ Static water level (date) (5) Combined USCS symbols used for fines between 5% and 12%
---	---

Classifications of soils in this report are based on visual field and/or laboratory observations, which include density/consistency, moisture condition, grain size, and plasticity estimates and should not be construed to imply field or laboratory testing unless presented herein. Visual-manual and/or laboratory classification methods of ASTM D-2487 and D-2488 were used as an identification guide for the Unified Soil Classification System.





associated
earth sciences
incorporated

Exploration Boring

Project Number
190224E001

Exploration Number
EB-1

Sheet
1 of 1

Project Name Kopachuck State Park
Location Pierce County, WA
Driller/Equipment Boretac / Limited Access Rig
Hammer Weight/Drop 140# / 30

Ground Surface Elevation (ft) _____
Datum NAVD 88
Date Start/Finish 8/8/19, 8/8/19
Hole Diameter (in) 6

Depth (ft)	S T	Samples	Graphic Symbol	DESCRIPTION	Well Completion	Water Level	Blows/Foot				Other Tests	
							Blows/6"	10	20	30		40
				Grass / Topsoil - ~2 inches								
		S-1		Colluvium Moist, brownish gray to dark brown, SILT, trace sand; clean sand lenses (1/16 inch thick); mottled texture with areas of heavy oxidation (ML).		5 5 5	▲10					
		S-2		Very moist, light brownish gray with bands of minor oxidation, SILT; minor fine organics; massive (ML).		3 4 4	▲8					
5		S-3		Very moist, gray to light brownish gray with bands of minor oxidation, SILT; minor fine organics; minor mica flakes; massive (ML).		3 2 4	▲6					
10		S-4		Moist, dark gray, SILT; minor mica flakes; few zones of brecciated texture with angular fracture planes; faint laminations (ML).		3 6 7	▲13					
				Pre-Fraser Fine Grained Deposits Slightly stiffer drilling at 13 feet.								
15		S-5		As above; minor areas of disturbed texture with possible slip planes.		11 15 21				▲36		
20		S-6		As above; less disturbed zones.		11 16 19				▲35		
25		S-7		As above.		21 16 19				▲35		
30		S-8		As above; slight increase in moisture.		18 25 28					▲53	
				Bottom of exploration boring at 31.5 feet No groundwater encountered.								

AESIBOR 190224.GPJ September 9, 2019

Sampler Type (ST):

- 2" OD Split Spoon Sampler (SPT)
- 3" OD Split Spoon Sampler (D & M)
- Grab Sample
- No Recovery
- Ring Sample
- Shelby Tube Sample
- M - Moisture
- ∇ Water Level ()
- ▼ Water Level at time of drilling (ATD)

Logged by: TG
Approved by: JHS



associated
earth sciences
incorporated

Exploration Boring

Project Number
190224E001

Exploration Number
EB-2

Sheet
1 of 1

Project Name Kopachuck State Park
Location Pierce County, WA
Driller/Equipment Boretac / Limited Access Rig
Hammer Weight/Drop 140# / 30

Ground Surface Elevation (ft) _____
Datum NAVD 88
Date Start/Finish 8/8/19, 8/8/19
Hole Diameter (in) 6

Depth (ft)	SPT	Samples	Graphic Symbol	DESCRIPTION	Well Completion	Water Level	Blows/Foot				Other Tests	
							10	20	30	40		
				Crushed Rock / Topsoil - ~4 inches								
		S-1		Colluvium Moist, dark brown to light brown, SILT, trace fine sand, trace gravel; wood debris possibly from tree roots; no apparent structure (ML).		7 9 8		▲	7			
		S-2		Moist, light brownish gray with bands of minor oxidation, SILT; minor organics; faintly laminated; zones of mottled texture (ML).		6 8 9		▲	7			
5		S-3		Moist, light brownish gray to brownish gray with bands of minor oxidation, SILT; minor fine organics; brecciated texture in zones (ML).		5 6 5		▲	11			
10		S-4		As above; color ranges to gray; minor mica flakes.		4 4 7		▲	11			
15		S-5		Very moist, brownish gray to gray with bands of minor oxidation, SILT; minor mica flakes; minor fine organics; angular fracture planes (variable inclinations); zones of brecciated texture (ML).		4 8 7		▲	15			
20		S-6		Moist, gray, SILT; minor mica flakes; minor zones of brecciated texture, mostly massive; angular fracture planes (low inclinations); slip plane features (ML).		5 6 8		▲	14			
				Pre-Fraser Coarse Grained Deposits								
				Harder/gravelly drilling at ~23 feet.								
25		S-7		Wet, brownish gray, gravelly, silty, fine to medium SAND, some coarse sand; faintly stratified (SM). Bottom of exploration boring at 26 feet Groundwater encountered at 25 feet.		▼ 40 50/5"						▲ 50/5"
30												

Sampler Type (ST):

- 2" OD Split Spoon Sampler (SPT)
- 3" OD Split Spoon Sampler (D & M)
- Grab Sample
- No Recovery
- Ring Sample
- Shelby Tube Sample
- M - Moisture
- ▼ Water Level ()
- ▼ Water Level at time of drilling (ATD)

Logged by: TG
Approved by: JHS



associated
earth sciences
incorporated

Exploration Boring

Project Number
190224E001

Exploration Number
EB-3

Sheet
1 of 1

Project Name Kopachuck State Park
Location Pierce County, WA
Driller/Equipment Boretac / Limited Access Rig
Hammer Weight/Drop 140# / 30

Ground Surface Elevation (ft) _____
Datum NAVD 88
Date Start/Finish 8/8/19, 8/8/19
Hole Diameter (in) 6

Depth (ft)	S T	Samples	Graphic Symbol	DESCRIPTION	Well Completion	Water Level	Blows/Foot				Other Tests	
							Blows/6"	10	20	30		40
				Crushed Rock / Topsoil - ~3 inches								
		S-1		Colluvium Moist, light brownish gray to brown, SILT, trace fine sand, trace gravel; minor organics and wood debris (tree roots); no apparent structure (ML).		6 4 5		▲ ₉				
		S-2		Very moist, brown to light brownish gray, SILT; minor fine organics; mottled texture with bands of minor oxidation; massive to faintly laminated (ML).		4 4 4		▲ ₈				
5		S-3		Moist, brown to gray bands of minor to moderate oxidation, SILT; minor mica flakes; zones of brecciated texture; angular fracture planes (variable inclinations); elevated moisture along fracture planes (ML).		4 4 5		▲ ₉				
				Stiffer drilling 7 to 8 feet.								
				Pre-Fraser Fine Grained Deposits								
10		S-4		Moist, gray with bands of minor oxidation, SILT; coarse silt partings; faintly laminated in zones; angular fracture planes (variable inclinations) with slip plane features (ML).		13 20 25						▲ ₄₅
15		S-5		As above; ranges to massive.		11 15 21						▲ ₃₆
20		S-6		As above.		18 29 31						▲ ₆₀
				Slightly harder drilling at ~22 feet.								
				Gravelly/harder drilling at ~24 feet.								
				Pre-Fraser Coarse Grained Deposits								
25		S-7		Wet, brownish gray to dark grayish brown, gravelly, fine to coarse SAND, trace silt; massive to faintly stratified (SP). ~5 feet of water on rods when sampling.		17 45 34						▲ ₇₉
				Bottom of exploration boring at 26.5 feet Groundwater encountered at 25 feet. Hole left open for ~20 minutes and water level rose in hole over the course of ~20 minutes from ~25 feet when sampling at 25 feet to ~12 feet 20 minutes later.								
30												

Sampler Type (ST):

- 2" OD Split Spoon Sampler (SPT)
- 3" OD Split Spoon Sampler (D & M)
- Grab Sample
- No Recovery
- Ring Sample
- Shelby Tube Sample
- M - Moisture
- ▽ Water Level ()
- ▽ Water Level at time of drilling (ATD)

Logged by: TG
Approved by: JHS



associated
earth sciences
incorporated

Exploration Boring

Project Number
190224E001

Exploration Number
EB-4

Sheet
1 of 1

Project Name Kopachuck State Park Ground Surface Elevation (ft) _____
 Location Pierce County, WA Datum NAVD 88
 Driller/Equipment Boretac / Limited Access Rig Date Start/Finish 8/8/19, 8/8/19
 Hammer Weight/Drop 140# / 30 Hole Diameter (in) 6

Depth (ft)	S T	Samples	Graphic Symbol	DESCRIPTION	Well Completion	Water Level	Blows/Foot				Other Tests		
							Blows/6"	10	20	30		40	
				Crushed Rock / Topsoil - ~3 inches									
		S-1		Colluvium Moist, light brownish gray to gray with bands of minor oxidation, SILT, trace fine sand, trace gravel; minor fine organics; massive to faintly laminated (ML).		7 6 6		▲12					
		S-2		Very moist, light brownish gray to gray, SILT; minor fine organics; zones of mottling and bands of minor to moderate oxidation; brecciated texture in zones (ML).		5 3 3		▲6					
5		S-3		As above; trace gravel.		4 4 5		▲9					
10		S-4		Moist, brownish gray to gray bands of minor oxidation, SILT; minor fine organics; minor mica flakes; angular fracture planes with slip surfaces (ML). Stiffer drilling ~11.5 to 12 feet.		9 10 14			▲24				
				Pre-Fraser Fine Grained Deposits									
15		S-5		Moist, gray, SILT; minor mica flakes; angular fracture planes with slip surfaces (variable inclinations); massive (ML).		12 16 17						▲33	
				Bottom of exploration boring at 16.5 feet No groundwater encountered.									

AESIBOR 190224.GPJ September 9, 2019

Sampler Type (ST):

- 2" OD Split Spoon Sampler (SPT)
- 3" OD Split Spoon Sampler (D & M)
- Grab Sample
- No Recovery
- Ring Sample
- Shelby Tube Sample
- M - Moisture
- Water Level ()
- Water Level at time of drilling (ATD)

Logged by: TG
Approved by: JHS

LOG OF EXPLORATION PIT NO. EP-1

Depth (ft)	DESCRIPTION
	This log is part of the report prepared by Associated Earth Sciences, Inc. (AESI) for the named project and should be read together with that report for complete interpretation. This summary applies only to the location of this trench at the time of excavation. Subsurface conditions may change at this location with the passage of time. The data presented are a simplification of actual conditions encountered.
	Forest Duff
1	Weathered Vashon Lodgement Till
2	Very stiff, dry to slightly moist, light brown, fine sandy, SILT, trace gravel; abundant rootlets and organics; unsorted (ML).
3	Medium dense, slightly moist, light brown with faint orange mottling, very silty, fine SAND, trace fine gravel; occasional fine laminae otherwise unsorted (SM).
4	
5	Vashon Advance Outwash / Pre-Fraser Deposits Undifferentiated
6	Very stiff, slightly moist, gray with some dark gray staining, SILT; massive; fine disseminated organics (ML).
7	Occasional fine sand interbeds.
8	Pre-Fraser Deposits Undifferentiated
9	Hard, slightly moist, gray with some light brown and dark gray mottling, SILT; some fine laminae, otherwise massive; fine disseminated organics (ML).
10	Bottom of exploration pit at depth 8 feet No seepage. Minor caving 0 to 2 feet.
11	
12	
13	
14	
15	
16	
17	
18	
19	
20	

KCTP3 180234.GPJ August 23, 2018

Kopachuck State Park Pierce County, WA

Logged by: LBK
Approved by: JHS



Project No. 180324E001
7/31/18

LOG OF EXPLORATION PIT NO. EP-2

Depth (ft)	
	<p>This log is part of the report prepared by Associated Earth Sciences, Inc. (AESI) for the named project and should be read together with that report for complete interpretation. This summary applies only to the location of this trench at the time of excavation. Subsurface conditions may change at this location with the passage of time. The data presented are a simplification of actual conditions encountered.</p> <p>DESCRIPTION</p>
	Forest Duff
1	Weathered Vashon Lodgement Till
2	Medium dense, dry to slightly moist, light brown, silty, fine SAND, trace fine gravel; abundant rootlets and organics; unsorted (SM).
3	
4	Vashon Advance Outwash
5	Medium dense, dry to slightly moist, light brown with faint orange staining, silty, fine SAND, trace gravel; thickly bedded (4 to 6 inches thick) (SM).
6	
7	Occasional silt lens.
8	Pre-Fraser Deposits Undifferentiated
9	Hard, slightly moist, gray with dark gray mottling, SILT; faint laminae; fine disseminated organics (ML).
10	Bottom of exploration pit at depth 8.5 feet No seepage. Minor caving 0 to 4 feet.
11	
12	
13	
14	
15	
16	
17	
18	
19	
20	

KCTP3 180234.GPJ August 23, 2018

Kopachuck State Park Pierce County, WA

Logged by: LBK
Approved by: JHS



a s s o c i a t e d
e a r t h s c i e n c e s
i n c o r p o r a t e d

Project No. 180324E001

7/31/18

LOG OF EXPLORATION PIT NO. EP-3

Depth (ft)	
	<p>This log is part of the report prepared by Associated Earth Sciences, Inc. (AESI) for the named project and should be read together with that report for complete interpretation. This summary applies only to the location of this trench at the time of excavation. Subsurface conditions may change at this location with the passage of time. The data presented are a simplification of actual conditions encountered.</p> <p>DESCRIPTION</p>
	Forest Duff
1	Weathered Vashon Advance Outwash
2	Medium dense, dry, light brown, silty, fine SAND; abundant roots and organics; massive (SP).
3	Vashon Advance Outwash
4	Medium dense, dry to slightly moist, light brown with faint orange mottling, fine SAND, some silt, some roots; massive (SP-SM).
5	
6	
7	Becomes grayish brown.
8	
9	Dense, slightly moist, grayish brown, silty, fine SAND; massive (SM).
10	
11	Bottom of exploration pit at depth 10 feet No seepage. Minor caving 0 to 3 feet.
12	
13	
14	
15	
16	
17	
18	
19	
20	

KCTP3 180234.GPJ August 23, 2018

Kopachuck State Park Pierce County, WA

Logged by: LBK
Approved by: JHS



a s s o c i a t e d
e a r t h s c i e n c e s
i n c o r p o r a t e d

Project No. 180324E001

7/31/18

Diana Dupuis
Director



STATE OF WASHINGTON

WASHINGTON STATE PARKS AND RECREATION COMMISSION

1111 Israel Rd S.W. • P.O. Box 42650 • Olympia, WA 98504-2650 • (360) 902-8500
TDD (Telecommunications Device for the Deaf): (360) 664-3133
www.parks.wa.gov

June 23, 2023

To: Brian Yearout, Project Manager

From: Chelsea Hamer, SW Region Environmental Planner

Subject: **KOPACHUCK STATE PARK ENVIRONMENTAL TRANSMITTAL
DAY USE DEVELOPMENT**

All the required environmental approvals have been obtained for the following proposal:

This project includes the renovation and expansion of the day-use area at Kopachuck, including a new kitchen and picnic shelter, ADA-compliant trails and picnic areas, improved water access, playground, interpretation, comfort station, and parking lot improvements.

This letter transmits the following environmental approvals to you for project implementation:

- 1. State Environmental Policy Act (SEPA) Compliance:** A Determination of Nonsignificance (DNS) was issued on July 11, 2014, with addenda issued May 16, 2019 and March 2, 2022. See Attachment 1.
- 2. Governor's Executive Order 21-02:** This project was reviewed by State Parks Archaeologist, Shari Silverman, and on April 22, 2019, the Department of Archaeology and Historic Preservation (DAHP) provided a letter of concurrence (Project Tracking #: 2018-12-09548-WSRPC) that the proposed project will have no adverse cultural resource impacts with the stipulation for an unanticipated discovery plan. See Attachment 2 for the Inadvertent Discovery Plan & Attachment 3 for the DAHP letter of concurrence.
- 3. Shoreline Management Act:** The Pierce County Department of Community Development & Pierce County Hearing Examiner issued a Shoreline Substantial Development, Shoreline Conditional Use, and Shoreline Variance Permit (Permit No. 906881, 906883, & 906884) on September 24, 2020 and was approved by the Washington Department of Ecology (ECY) on November 16, 2020. A one-year extension was approved on February 16, 2023 and expires on November 16, 2023 – work must commence prior to November 16, 2023, and must be completed by November 16, 2025; if construction cannot be completed by this date, it is possible

that a one-year extension may be granted. See Attachment 4.

4. **Critical Areas Review:** The Pierce County Department of Community Development completed a wetland and fish and wildlife review and issued a Critical Areas Title Notification (Permit No. 906888) on October 2, 2020. See Attachment 5.
5. **Tree Activity Worksheet:** A Tree Activity Worksheet (TAW) was approved on July 8, 2022 (email on file). Pierce County and the Department of Natural Resources each indicated that no forest practices permit is required for this project. See Attachment 6.

Please remember that it is your responsibility to understand all conditions of the various permits and approvals. Violation of regulatory requirements may result in civil and criminal penalties being assessed to the contractor and/or the agency.

Cc: Joel Pillers, Area Manager
Darrel Hopkins, Region Manager
Olyvia Buday, Park Ranger
Shari Silverman, Archaeologist
Dave Cass, Agency Forester
Tina Edwards, Program Coordinator

Attachment 1

SEPA MDNS & Checklist & Addenda



Don Hoch
Acting Director

STATE OF WASHINGTON
WASHINGTON STATE PARKS AND RECREATION COMMISSION
1111 Israel Rd S.W. • P.O. Box 42650 • Olympia, WA 98504-2650 • (360) 902-8500
TDD (Telecommunications Device for the Deaf): (360) 664-3133
www.parks.wa.gov

**ADDENDUM TO
DETERMINATION OF NON-SIGNIFICANCE**
Kopachuck State Park Day Use Master Plan

Addendum to: Kopachuck State Day Use Master Plan Project Determination of Non-Significance (DNS) and environmental checklist dated June 27, 2014, and addendum dated May 16, 2019.

Proponent: Washington State Parks and Recreation Commission

Location of Proposal: Kopachuck State Park is located at 10712 56th St. NW, Gig Harbor, WA 98335 in Pierce County. The park is located within Section 16, Township 21 North, Range 1 East.

Purpose of this Addendum: This addendum provides supplemental information to the environmental checklist including updated information since the project was originally proposed and new information for minor project modifications. This information does not change the overall conclusions of the checklist or the DNS. Rather, this information is intended to clarify and expand on the information in the checklist on which the DNS was based.

Only those portions of the checklist that are directly affected by the supplemental information are included below. Supplemental information is organized by section of the checklist. Modifications and/or clarifications to the checklist are noted using ~~strikeout~~ format for deletions and underlined **bold** type for additions.

A. BACKGROUND

6. Proposed timing or schedule:

The **Kopachuck State Park** master plan is ~~proposed for adoption~~ **was approved** by the Washington State Parks and Recreation Commission ~~by the end of~~ **in** July 2014. ~~Construction of all or a portion of the improvements is scheduled tentatively for the 2016-2017 biennium.~~ **The project has been split into three phases.**

Phase 1: The initial phase constructs the upper day use area. Elements of this phase include reconstructing the parking lot and entry and exit roads; a day-use building; a welcome center; an ADA-accessible picnic area; amphitheater and play area; as well

as new water, sewer, and stormwater systems.

Phase 2: This phase proposes to construct the lower beach area. Elements include ADA beach access and restroom; an improved beach area (pocket beach); and interpretive exhibits; an ADA beach overlook and accessible picnic area; path with interpretive exhibits; and paving of the existing gravel road and ADA parking.

Phase 3: The final phase proposes to construct new trails and improve existing trails.

Timing of construction for all phases of proposed Master Plan improvements will be dependent on availability of funding and permitting timelines but work on Phases 1 & 2 is anticipated to start in 2019-2020-2022.

8. List any environmental information you know about that has been prepared, or will be prepared, directly related to this proposal.

~~A geologic hazard site reconnaissance and document review was conducted by Associated Earth Sciences, Inc. in November 2012. A wetland delineation, analysis report, and potential wetland mitigation plan will be prepared. If mooring buoys are placed within 30' of the MLLW, an eelgrass survey will be required.~~

Associated Earth Sciences, Inc. 2012. Geologic Evaluation of Proposed Tree Removal. November 16.

Associated Earth Sciences, Inc. 2018. Draft Subsurface Exploration, Geologic Hazard, and Geotechnical Engineering Report. August 29.

Associated Earth Sciences, Inc. 2020. Landslide Hazard Geotechnical Report. Revised May 26.

PND Engineers, Inc. 2018. Field Report – Onsite Sewage System Site Investigation. August 7.

PND Engineers, Inc. and Bruce Dees & Associates. 2019. Habitat Assessment for the Kopachuck State Park Day Use Area Development, Washington State Parks. February 27.

Soundview Consultants. 2019. Wetland Analysis Report – Kopachuck State Park. February 15.

Washington State Parks and Recreation Commission. 2014. Kopachuck State Park Master Plan Report. June 27.

10. List any government approvals or permits that will be needed for your proposal, if known.

Pierce County Approvals

K) Forest Practices Permit

~~K) Hydraulic Project Approval: HPA work along the shoreline will be reviewed by the Washington State Department of Ecology (DOE)~~

~~L) JARPA application to the Army Corps of Engineers (ACOE) will be submitted to the Department of Natural Resources (DNR) and the DOE for review.~~

~~M) A separate application will be made to the Washington State Department of Fish and Wildlife (WDFW) for their review.~~

11. Give brief, complete description of your proposal, including the proposed uses and the size of the project and site. There are several questions later in this checklist that ask you to describe certain aspects of your proposal. You do not need to repeat those answers on this page.

The primary elements of the plan include:

A) Upper Day Use Area

- 1) New Kitchen/Shelter/Restroom
- 2) Picnic Area
- 3) Children's Play Area
- 4) Outdoor Amphitheatre

B) View Point and Beach Area

- ~~1) New restrooms~~
- ~~2) ADA-accessible viewing decks~~
- ~~3) Improved beach access~~
- ~~4) Additional mooring buoys~~
- ~~5) Relocated Cascadia Marine Trail campsite~~

6) ADA-accessible beach overlook and picnic area

C) Loop Interpretive Trail System Improvements

- ~~1) Six (6) connected and improved loop trails and interpretive story points~~
- 2) Trail connection to Voyager Middle School

D) Road and Parking Lot Improvements

- 1) Revised park entry/exit
- 2) Upper day use parking lot improvements
- 3) Welcome center/park office
- 4) Paved access drive to the beach use area
- 5) ~~Six (6)~~ **Three (3)** car parking lot at the interpretive trail

E) Forest Management Plan

B. ENVIRONMENTAL ELEMENTS

1. Earth

- e. Describe the purpose, type, and approximate quantities of any filling or grading proposed. Indicate source of fill.

Minor earthwork will be required in order to construct the plan as it has been developed.

Phase 1 grading in the upper day-use area will require approximately 1,494 CY of cut and 2,406 CY of fill. 3,600 cubic yards of cut/fill. A fine import crushed rock will be used on the beach trail for drainage. There is a 2-3' high bank above the ordinary high water with wooden stairs to the beach. **The proposed pocket beach (Phase 2) will** is to extend the scope of the **existing** gravel beach (approximately 4:1) landward **from the ordinary high water mark (OHWM) to the proposed ADA-accessible path. Creation of the pocket beach will require excavation of approximately 277 cubic yards of material (1,500 square feet). The upland edge of the beach and sides will be protected by a buried sheet pile wall with a concrete cap or large rocks. The sheet pile, rock edge, and proposed native plantings will protect and stabilize the sides and toe of the existing soil on each side of the pocket beach. The beach material is proposed to be approximately two feet thick (56 cubic yards) and will consist of gravel matching the existing beach gravel gradation. Any fill will be sourced from an approved commercial facility.** to eliminate the stairs and provide direct pedestrian access to the beach. No filling will occur on the beach.

3. Water

a. Surface

- a. Is there any surface water body on or in the immediate vicinity of the site (including year-round and seasonal streams, saltwater, lakes, ponds, wetlands)? If yes, describe type and provide names. If appropriate, state what stream or river it flows into.

Other than the saltwater shore of Colvos Passage **Carr Inlet**, there are no year-round or seasonal streams. **A wetland assessment of the project area, conducted on December 13, 2018 and January 3, 2019, identified seven Category IV wetlands on the property (Soundview Consultants 2019). The proposed project will avoid impacts to these wetlands.** There are some wetted depressional areas that have not yet been delineated. There are drainages and depressions in the terrain but no streams. All potential wetland trail crossings will require delineation and possible mitigation. Jurisdictional determination must be made by the ACOE.

- b. Will the project require any work over, in, or adjacent to (within 200 feet) the described waters? If yes, please describe and attach available plans.

Improvements in the beach area **will occur within 200 feet of the Carr Inlet shoreline** including extending the backshore area **to create a pocket beach, construction of a new ADA beach access path, replacing the restroom, installation of a stormwater collection and treatment system, paving the beach access road, and other minor site improvements.**

The project will create a pocket beach by extending the existing gravel beach landward from the OHWM. The OHWM along the shoreline is at approximately +9 feet. The pocket beach will extend from above the OHWM to +17 feet where it will meet with a new ADA-accessible path. The ADA path will extend from the top of the pocket beach to the existing restroom parking lot. The upland edge of the beach and sides will be protected by a buried sheet pile wall with a concrete cap or large rocks. The slopes of either side of the beach will be replanted with native species to help stabilize the area.

~~**A new ADA-compliant restroom will be installed in the lower beach area to replace the previous restroom. The restroom will have two stalls, an outdoor rinsing shower, and small custodial storage. The restroom will be adjacent to the parking lot and will provide direct access to the pocket beach.**~~

~~**Stormwater from the parking lot, buildings and roads will be collected and routed down the beach access road. All runoff will then be tight lined to a stormwater biofiltration treatment vault at the end of the road. Following treatment, the water will be directed to a dispersion trench filled with drain rock buried under the new pocket beach near the beach.**~~

~~**Other site improvements include paving the beach access road and parking area.** will be within 200' of the Colvos Passage shoreline. ~~**In addition,**~~ ~~**Two**~~ mooring buoys ~~**may**~~ will be added to the two existing buoys. The proposed trail routes will be delineated and the rating established. The square footage of the wetland areas is unknown at this time.~~

4. Will the proposal require surface water withdrawals or diversions? Give general description, purpose, and approximate quantities if known.

~~**No, the proposal will not require surface water withdrawals or diversions.**~~ Surface water runoff from the existing parking lot and roads will be redirected to rain gardens or a bioswale.

5. Does the proposal lie within a 100-year floodplain? If so, note location on the site plan.

~~**Per the Pierce County PublicGIS map (accessed December 11, 2018), the shoreline along the lower beach area is within the regulated Floodplain (2017).**~~ No, the site does not lie within a 100-year floodplain.

c. Water runoff (including stormwater)

1. Describe the source of runoff (including storm water) and method of collection and disposal, if any (include quantities, if known). Where will this water flow? Will this water flow into other waters? If so, describe.

~~**Stormwater from the parking lot, buildings and roads will be collected and routed down the beach access road. All runoff will then be tight lined to a stormwater biofiltration treatment vault at the end of the road. Following treatment, the water will be directed to a level spreader/infiltration trench filled with drain rock. All disturbed pervious and new pollution-generating areas will be mechanically treated before being directed to the level spreader/infiltration trench under the pocket beach. Surface runoff will be collected by catch basins and conveyed to a bioswale or rain gardens north of the parking lot via a pipe in the parking lot. From there, water will be piped to a point above the shoreline and allowed to dissipate via an overflow structure.**~~

4. Plants

- b. What kind and amount of vegetation will be removed or altered?

To the extent possible, existing vegetation will be preserved on site. The project has been located and designed to avoid and minimize impacts to existing trees. State Parks will identify dead/hazard trees and other trees that will require removal based on potential critical root zone impacts. It is anticipated that the number of trees to be removed will be significantly less than 5,000 board feet and, therefore, will not require application or notification to the Department of Natural Resources (per Forest Practices Rules WAC 221-12-030) approximately 9,320 board feet. The proposed tree removal is located within one and one-half tree lengths from existing structures and is therefore not considered as forestland per Department of Natural Resources (DNR) guidance. A site visit was conducted with DNR staff and an Informal Conference Note (ICN) was provided on September 29, 2021 indicating that a Forest Practices Application was not required by DNR. Only vegetation under the building footprint will be removed (approximately 2,500 SF).

Approximately 60,000 square feet of existing paving will be removed and those areas planted. **The intent is to salvage and replant native vegetation (primarily sword fern) to infill adjacent to improvements and to restore existing areas devoid of vegetation. The total area of vegetation removal and replanting is 3,060 square feet. Additional plantings will occur to restore remaining disturbed areas. All planted and transplanted areas in the upper Day Use Area will be irrigated with drip line.**

As part of the lower beach area improvements, native plants will be used to help stabilize slopes and to restore habitat where trails are being removed. All trails within wetlands will be on elevated fiberglass grating which will allow continuous light and rain penetration. No vegetation will be removed **removal is proposed for trail improvements in wetland areas.**

- d. Proposed landscaping, use of native plants, or other measures to preserve or enhance vegetation on site, if any?

To the extent possible, existing vegetation will be preserved on site. The project has been located and designed to avoid and minimize impacts to existing trees. A Tree Conservation Plan and/or Landscape Planting Plan will be developed for all phases of the project. Where feasible, the project will transplant plants from the development footprint and transplant them into proposed landscape and restoration areas. Additional plantings will occur to restore remaining disturbed areas. All new planting will be with native plants.

5. Animals

- b. List any threatened or endangered species known to be on or near the site.

According to the U.S. Fish & Wildlife Services Information for Planning and Consultation (IPaC) Tool (accessed October 25, 2021), the following species may potentially be found on or near the site.

Marbled murrelet (*Brachyramphus marmoratus*), threatened
Streaked horned lark (*Eremophila alpestris strigata*), threatened
Yellow-billed cuckoo (*Coccyzus americanus*), threatened
Bull trout (*Salvelinus confluentus*), threatened
Taylor's checkerspot (*Euphydryas editha taylori*), endangered

Monarch butterfly (*Danaus plexippus*), candidate

According to the Washington Department of Fish & Wildlife (WDFW) Priority Habitats and Species (PHS) data (accessed October 25, 2021), the following habitats and species are documented within or in the vicinity of Kopachuck State Park.

Surf smelt spawning

Hardshell clam

Geoduck

Great blue heron (*Ardea herodias*) breeding colony

Estuarine and marine wetland

8. Land and Shoreline Use

e. What is the current zoning classification of the site?

Park & Recreation (PR) R-10

l. Proposed measures to ensure the proposal is compatible with existing and projected land uses and plans, if any:

A pre-submittal meeting was conducted with Pierce County staff. They indicated that the proposal appears to be compatible with the existing and projected land uses and plans. **A follow-up pre-submittal meeting for Phase 1 was conducted on December 6, 2018. State Parks will continue to work closely with the County during the planning process for all proposed phases and will obtain and adhere to any and all required permits, approvals and conditions.**

13. Historic and Cultural Preservation

c. Proposed measures to reduce or control impacts, if any:

The project will require compliance with Governor's Executive Order 05-05. As a result, a cultural resources survey of the project site will be conducted prior to development. The resulting cultural resource survey report will be shared with DAHP and concerned tribes as part of the consultation process. An inadvertent discovery plan to address any unanticipated discoveries made during construction will be developed and incorporated in the final construction plans. ~~In compliance with Chapter 27.44 RCW, Chapter 27.53 RCW, and DAHP rules and regulations, contract specifications for proposed improvements will contain provisions for the protection of cultural resources. Overnight use of Cutts Island, as well as campfires and the removal of any vegetation in the park, is prohibited.~~

Lead agency: Washington State Parks and Recreation Commission

The DNS issued for the proposed project is added to by the authority provided in WAC 197-11-600(4)(c) and conforms to the procedures for preparing an addendum in WAC 197-11-625. The updated information provided does not substantially change the analysis of significant impacts in the existing environmental checklist. Based on the original DNS and the updated information provided in this addendum, we have determined that a new threshold determination is not warranted. There is no comment period associated with this SEPA addendum. This addendum will be placed in the agency Central Files.

SEPA Addendum
Kopachuck Day Use Master Plan
March 7, 2022
Page 8 of 6

Responsible Official: Chelsea Hamer
Position/Title: SW Region Environmental Planner
Phone: (360) 725-9764
Address: 1111 Israel Rd SW, PO Box 42650
Olympia, WA 98504-2650

Date of Issue: 03/02/2022

Signature: 



Don Hoch
Director

STATE OF WASHINGTON
WASHINGTON STATE PARKS AND RECREATION COMMISSION

1111 Israel Rd S.W. • P.O. Box 42650 • Olympia, WA 98504-2650 • (360) 902-8500
TDD (Telecommunications Device for the Deaf): (360) 664-3133
www.parks.wa.gov

**ADDENDUM TO
DETERMINATION OF NON-SIGNIFICANCE**

Kopachuck State Park Day Use Master Plan

Addendum to: Kopachuck State Day Use Master Plan Project Determination of Non-Significance (DNS) and environmental checklist dated June 27, 2014.

Proponent: Washington State Parks and Recreation Commission

Location of Proposal: Kopachuck State Park is located at 10712 56th St. NW, Gig Harbor, WA 98335 in Pierce County. The park is located within Section 16, Township 21 North, Range 1 East.

Purpose of this Addendum: This addendum provides supplemental information to the environmental checklist including updated information since the project was originally proposed and new information for minor project modifications. This information does not change the overall conclusions of the checklist or the DNS. Rather, this information is intended to clarify and expand on the information in the checklist on which the DNS was based.

Only those portions of the checklist that are directly affected by the supplemental information are included below. Supplemental information is organized by section of the checklist. Modifications and/or clarifications to the checklist are noted using ~~strikeout~~ format for deletions and underlined **bold** type for additions.

A. BACKGROUND

6. Proposed timing or schedule:

The **Kopachuck State Park** master plan is ~~proposed for adoption~~ **was approved** by the Washington State Parks and Recreation Commission ~~by the end of~~ **in** July 2014. ~~Construction of all or a portion of the improvements is scheduled tentatively for the 2016-2017 biennium.~~ **The project has been split into three phases.**

Phase 1: The initial phase constructs the upper day use area. Elements of this phase include reconstructing the parking lot and entry and exit roads; a day-use building; a welcome center; as ADA-accessible picnic area; amphitheater and play area; as well as new water, sewer, and stormwater systems.

Phase 2: This phase proposes to construct the lower beach area. Elements include ADA beach access and restroom; an improved beach area (pocket beach); and interpretive exhibits.

Phase 3: The final phase proposes to construct new trails and improve existing trails.

Timing of construction for all phases of proposed Master Plan improvements will be dependent on availability of funding and permitting timelines but work on Phase 1 is anticipated to start in 2019-2020.

8. List any environmental information you know about that has been prepared, or will be prepared, directly related to this proposal.

~~A geologic hazard site reconnaissance and document review was conducted by Associated Earth Sciences, Inc. in November 2012. A wetland delineation, analysis report, and potential wetland mitigation plan will be prepared. If mooring buoys are placed within 30' of the MLLW, an eelgrass survey will be required.~~

Associated Earth Sciences, Inc. 2012. Geologic Evaluation of Proposed Tree Removal. November 16.

Associated Earth Sciences, Inc. 2018. Draft Subsurface Exploration, Geologic Hazard, and Geotechnical Engineering Report. August 29.

PND Engineers, Inc. 2018. Field Report – Onsite Sewage System Site Investigation. August 7.

PND Engineers, Inc. and Bruce Dees & Associates. 2019. Habitat Assessment for the Kopachuck State Park Day Use Area Development, Washington State Parks. February 27.

Soundview Consultants. 2019. Wetland Analysis Report – Kopachuck State Park. February 15.

Washington State Parks and Recreation Commission. 2014. Kopachuck State Park Master Plan Report. June 27.

B. ENVIRONMENTAL ELEMENTS

1. Earth

- e. Describe the purpose, type, and approximate quantities of any filling or grading proposed. Indicate source of fill.

Minor earthwork will be required in order to construct the plan as it has been developed. **Phase 1 grading in the upper day-use area will require approximately**

3,600 cubic yards of cut/fill. A fine import crushed rock will be used on the beach trail for drainage. There is a 2-3' high bank above the ordinary high water with wooden stairs to the beach. **The proposed pocket beach (Phase 2) will** is to extend the scope of the **existing** gravel beach (approximately 4:1) landward **from the ordinary high water mark (OHWM) to the proposed ADA-accessible path.** **Creation of the pocket beach will require excavation of approximately 277 cubic yards of material (1,500 square feet).** **The upland edge of the beach and sides will be protected by a buried sheet pile wall with a concrete cap or large rocks. The sheet pile, rock edge, and proposed native plantings will protect and stabilize the sides and toe of the existing soil on each side of the pocket beach. The beach material is proposed to be approximately two feet thick (56 cubic yards) and will consist of gravel matching the existing beach gravel gradation. Any fill will be sourced from an approved commercial facility.** to eliminate the stairs and provide direct pedestrian access to the beach. No filling will occur on the beach.

3. Water

a. Surface

1. Is there any surface water body on or in the immediate vicinity of the site (including year-round and seasonal streams, saltwater, lakes, ponds, wetlands)? If yes, describe type and provide names. If appropriate, state what stream or river it flows into.

Other than the saltwater shore of ~~Colvos Passage~~ **Carr Inlet**, there are no year-round or seasonal streams. **A wetland assessment of the project area, conducted on December 13, 2018 and January 3, 2019, identified seven Category IV wetlands on the property (Soundview Consultants 2019). The proposed project will avoid impacts to these wetlands.** There are some wetted depressional areas that have not yet been delineated. There are drainages and depressions in the terrain but no streams. All potential wetland trail crossings will require delineation and possible mitigation. Jurisdictional determination must be made by the ACOE.

2. Will the project require any work over, in, or adjacent to (within 200 feet) the described waters? If yes, please describe and attach available plans.

Improvements in the beach area **will occur within 200 feet of the Carr Inlet shoreline** including extending the backshore area **to create a pocket beach, construction of a new ADA beach access path, replacing the restroom, installation of a stormwater collection and treatment system, paving the beach access road, and other minor site improvements.**

The project will create a pocket beach by extending the existing gravel beach landward from the OHWM. The OHWM along the shoreline is at approximately +9 feet. The pocket beach will extend from above OHWM to +17 feet where it will meet with a new ADA-accessible path. The ADA path will extend from the top of the pocket beach to the existing restroom parking lot. The upland edge of the beach and sides will be protected by a buried sheet

pile wall with a concrete cap or large rocks. The slopes of either side of the beach will be replanted with native species to help stabilize the area.

A new ADA-compliant restroom will be installed in the lower beach area to replace the previous restroom. The restroom will have two stalls, an outdoor rinsing shower, and small custodial storage. The restroom will be adjacent to the parking lot and will provide direct access to the pocket beach.

Stormwater from the parking lot, buildings and roads will be collected and routed down the beach access road. All runoff will then be tight lined to a stormwater biofiltration treatment vault at the end of the road. Following treatment, the water will be directed to a dispersion trench filled with drain rock buried under the new pocket beach.

Other site improvements include paving the beach access road and parking area. will be within 200' of the Colvos Passage shoreline. **In addition,** ~~two mooring buoys may will be added to the two existing buoys. The proposed trail routes will be delineated and the rating established. The square footage of the wetland areas is unknown at this time.~~

4. Will the proposal require surface water withdrawals or diversions? Give general description, purpose, and approximate quantities if known.

No, the proposal will not require surface water withdrawals or diversions. ~~Surface water runoff from the existing parking lot and roads will be redirected to rain gardens or a bioswale.~~

5. Does the proposal lie within a 100-year floodplain? If so, note location on the site plan.

Per the Pierce County PublicGIS map (accessed December 11, 2018), the shoreline along the lower beach area is within the regulated Floodplain (2017). ~~No, the site does not lie within a 100-year floodplain.~~

c. Water runoff (including stormwater)

1. Describe the source of runoff (including storm water) and method of collection and disposal, if any (include quantities, if known). Where will this water flow? Will this water flow into other waters? If so, describe.

Stormwater from the parking lot, buildings and roads will be collected and routed down the beach access road. All runoff will then be tight lined to a stormwater biofiltration treatment vault at the end of the road. Following treatment, the water will be directed to a level spreader/infiltration trench filled with drain rock buried under the new pocket beach. All disturbed pervious and new pollution-generating areas will be mechanically treated before being directed to the level spreader/infiltration trench under the pocket

~~**beach.** Surface runoff will be collected by catch basins and conveyed to a bioswale or rain gardens north of the parking lot via a pipe in the parking lot. From there, water will be piped to a point above the shoreline and allowed to dissipate via an overflow structure.~~

4. Plants

- b. What kind and amount of vegetation will be removed or altered?

To the extent possible, existing vegetation will be preserved on site. The project has been located and designed to avoid and minimize impacts to existing trees. State Parks will identify dead/hazard trees and other trees that will require removal based on potential critical root zone impacts. It is anticipated that the number of trees to be removed will be significantly less than 5,000 board feet and, therefore, will not require application or notification to the Department of Natural Resources (per Forest Practices Rules WAC 221-12-030). Only vegetation under the building footprint will be removed (approximately 2,500 SF).

Approximately 60,000 square feet of existing paving will be removed and those areas planted. **The intent is to salvage and replant native vegetation (primarily sword fern) to infill adjacent to improvements and to restore existing areas devoid of vegetation. The total area of vegetation removal and replanting is 3,060 square feet. Additional plantings will occur to restore remaining disturbed areas. All planted and transplanted areas in the upper Day Use Area will be irrigated with drip line.**

As part of the lower beach area improvements, native plants will be used to help stabilize slopes adjacent to the proposed pocket beach, and to restore habitat where trails are being removed. All trails within wetlands will be on elevated fiberglass grating which will allow continuous light and rain penetration. No vegetation ~~will be removed~~ **removal is proposed for trail improvements in wetland areas.**

- d. Proposed landscaping, use of native plants, or other measures to preserve or enhance vegetation on site, if any?

To the extent possible, existing vegetation will be preserved on site. The project has been located and designed to avoid and minimize impacts to existing trees. A Tree Conservation Plan and/or Landscape Planting Plan will be developed for all phases of the project. Where feasible, the project will transplant plants from the development footprint and transplant them into proposed landscape and restoration areas. Additional plantings will occur to restore remaining disturbed areas. All new planting will be with native plants.

8. Land and Shoreline Use

- e. What is the current zoning classification of the site?

Park & Recreation (PR) R-10

1. Proposed measures to ensure the proposal is compatible with existing and projected land uses and plans, if any:

A pre-submittal meeting was conducted with Pierce County staff. They indicated that the proposal appears to be compatible with the existing and projected land uses and plans. **A follow-up pre-submittal meeting for Phase 1 was conducted on December 6, 2018. State Parks will continue to work closely with the County during the planning process for all proposed phases and will obtain and adhere to any and all required permits, approvals and conditions.**

13. Historic and Cultural Preservation

- c. Proposed measures to reduce or control impacts, if any:

The project will require compliance with Governor's Executive Order 05-05. As a result, a cultural resources survey of the project site will be conducted prior to development. The resulting cultural resource survey report will be shared with DAHP and concerned tribes as part of the consultation process. An inadvertent discovery plan to address any unanticipated discoveries made during construction will be developed and incorporated in the final construction plans. In compliance with Chapter 27.44 RCW, Chapter 27.53 RCW, and DAHP rules and regulations, contract specifications for proposed improvements will contain provisions for the protection of cultural resources. Overnight use of Cutts Island, as well as campfires and the removal of any vegetation in the park, is prohibited.

Lead agency: Washington State Parks and Recreation Commission

The DNS issued for the proposed project is added to by the authority provided in WAC 197-11-600(4)(c) and conforms to the procedures for preparing an addendum in WAC 197-11-625. The updated information provided does not substantially change the analysis of significant impacts in the existing environmental checklist. Based on the original DNS and the updated information provided in this addendum, we have determined that a new threshold determination is not warranted. There is no comment period associated with this SEPA addendum. This addendum will be placed in the agency Central Files.

Responsible Official: Jessica A. Norton
Position/Title: SW Region Environmental Planner
Phone: (360) 725-9755
Address: 1111 Israel Rd SW, PO Box 42650
Olympia, WA 98504-2650

Date of Issue: May 16, 2019

Signature: _____

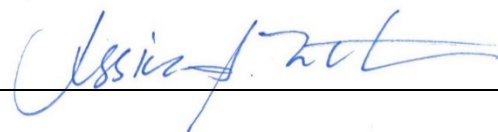

Don Hoch
Director



STATE OF WASHINGTON
WASHINGTON STATE PARKS AND RECREATION COMMISSION

1111 Israel Road SW • P.O. Box 42650 • Olympia, Washington 98504-2650
(360) 902-8500 • Washington Telecommunications Relay Service at (800) 833-6388
www.parks.wa.gov

DETERMINATION OF NONSIGNIFICANCE
STATE ENVIRONMENTAL POLICY ACT

Description of proposal: Washington State Parks is in the final stages of completing a planning process at Kopachuck State Park. The *Kopachuck State Park Day Use Master Plan* is intended to provide a long-term guide for development that meets the needs and desires of the public. Elements of the plan include day use facilities, view point and beach area improvements, trail system improvements, road and parking lot improvements and a forest management plan.

Proponent: Washington State Parks and Recreation Commission

Location of proposal, including street address, if any: Kopachuck State Park is a 109-acre day-use park located on the shore of Henderson Bay, five miles west of the city of Gig Harbor in Pierce County. The park address is 10712 56th St. N.W., Gig Harbor, WA 98335.

Lead agency: Washington State Parks and Recreation Commission

The lead agency for this proposal has determined that it does not have a probable significant adverse impact on the environment. An environmental impact statement (EIS) is not required under RCW 43.21C.030(2)(c). This decision was made after review of a completed environmental checklist and other information on file with the lead agency. This information is available to the public on request.

This DNS is issued under 197-11-340 (2); the lead agency will not act on this proposal for 14 days from the date below. Comments must be submitted by **July 11, 2014** or they may not be considered.

Responsible Official: Randy Kline
Position/Title: Environmental Program Manager
Phone/Email: (360) 902-8632/randy.kline@parks.wa.gov
Address: P.O. Box 42650, Olympia, WA 98504

Date: June 27, 2014

Signature: 

"All Washington State Parks are developed and maintained for the enjoyment of all persons regardless of age, sex, creed, ethnic origin, or physical limitations." There is no agency SEPA appeal; however all comments are welcome and will be thoroughly considered.

WAC 197-11-960 Environmental Checklist.

ENVIRONMENTAL CHECKLIST

Purpose of checklist:

The State Environmental Policy Act (SEPA), chapter 43.21C RCW, requires all governmental agencies to consider the environmental impacts of a proposal before making decisions. An environmental impact statement (EIS) must be prepared for all proposals with probable significant adverse impacts on the quality of the environment. The purpose of this checklist is to provide information to help you and the agency identify impacts from your proposal (and to reduce or avoid impacts from the proposal, if it can be done) and to help the agency decide whether an EIS is required.

Instructions for applicants:

This environmental checklist asks you to describe some basic information about your proposal. Governmental agencies use this checklist to determine whether the environmental impacts of your proposal are significant, requiring preparation of an EIS. Answer the questions briefly, with the most precise information known, or give the best description you can.

You must answer each question accurately and carefully, to the best of your knowledge. In most cases, you should be able to answer the questions from your own observations or project plans without the need to hire experts. If you really do not know the answer, or if a question does not apply to your proposal, write "do not know" or "does not apply." Complete answers to the questions now may avoid unnecessary delays later.

Some questions ask about governmental regulations, such as zoning, shoreline, and landmark designations. Answer these questions if you can. If you have problems, the governmental agencies can assist you.

The checklist questions apply to all parts of your proposal, even if you plan to do them over a period of time or on different parcels of land. Attach any additional information that will help describe your proposal or its environmental effects. The agency to which you submit this checklist may ask you to explain your answers or provide additional information reasonably related to determining if there may be significant adverse impact.

Use of checklist for nonproject proposals:

Complete this checklist for nonproject proposals, even though questions may be answered "does not apply." IN ADDITION, complete the SUPPLEMENTAL SHEET FOR NONPROJECT ACTIONS (part D).

For non-project actions, the references in the checklist to the words "project," "applicant," and "property or site" should be read as "proposal," "proposer," and "affected geographic area," respectively.

A. BACKGROUND

1. Name of proposed project, if applicable:

Kopachuck State Park Day Use Master Plan

2. Name of applicant:

Washington State Parks and Recreation Commission

3. Address and phone number of applicant and contact person:

Brian Yearout, Project Manager

Washington State Parks and Recreation Commission

1111 Israel Road SW

Olympia, WA 98504-2650

Brian.Yearout@parks.wa.gov

(360) 725-9763

4. Date checklist prepared:
May 2014
5. Agency requesting checklist:
Washington State Parks and Recreation Commission
6. Proposed timing or schedule (including phasing, if applicable):
The master plan is proposed for adoption by the Washington State Parks and Recreation Commission by the end of July 2014. Construction of all or a portion of the improvements is scheduled tentatively for the 2016-2017 biennium.
7. Do you have any plans for future additions, expansion, or further activity related to or connected with this proposal? If yes, explain.
There are no plans for expanding the park or for any improvements beyond the proposed master plan.
8. List any environmental information you know about that has been prepared, or will be prepared, directly related to this proposal.
A geologic hazard site reconnaissance and document review was conducted by Associated Earth Sciences, Inc. in November 2012. A wetland delineation, analysis report, and potential wetland mitigation plan will be prepared. If mooring buoys are placed within 30' of the MLLW, an eelgrass survey will be required.
9. Do you know whether applications are pending for governmental approvals of other proposals directly affecting the property covered by your proposal? If yes, explain.
There are no pending government approvals or other proposals directly affecting the property. However, included in the master plan is a recommendation for a forest management plan that would address the application of appropriate technical forestry principles and practices for forest management in order to achieve stated objectives. One of those objectives may be the restoration of individual and group camping facilities at Kopachuck State Park.
10. List any government approvals or permits that will be needed for your proposal, if known.
Some or all of the following approvals or permits may be required for full implementation of the master plan. Contacts will be made with each agency for their specific requirements at each phase of implementation.

Pierce County Approvals

- A) SEPA determination
- B) demolition permit
- C) building permit
- D) Conditional Use Permit (CUP) for the shoreline management area
- E) CUP for park and land use portion within the rural residential conservancy zone
- F) Shoreline Substantial Development Permit (SSDP)
- G) Shoreline Conditional Use Permit (SCUP)
- H) Title 18J Compliance
- I) Delineation of the trail route crossing any wetlands will be required to determine jurisdiction and possible mitigation if there are isolated wetlands determining County jurisdiction.
- J) Calculations and design will be submitted to Pierce County Health Department (TPHD) for onsite sewage disposal.

State Approvals

- K) Hydrolic Project Approval: HPA work along the shoreline will be reviewed by the Washington State Department of Ecology (DOE).
- L) JARPA application to the Army Corps of Engineers (ACOE) will be submitted to the Department of Natural Resources (DNR) and the DOE for review.
- M) A separate application will be made to the Washington State Department of Fish and Wildlife (WDFW) for their review.
- N) An NPDES permit associated with earthwork and erosion control will be required from the DOE.

Federal Review

- O) A JARPA application will be made to the ACOE for work along the shoreline.
- P) Mooring buoy locations will be reviewed by the US Coast Guard.

11. Give brief, complete description of your proposal, including the proposed uses and the size of the project and site. There are several questions later in this checklist that ask you to describe certain aspects of your proposal. You do not need to repeat those answers on this page. (Lead agencies may modify this form to include additional specific information on project description.)

The Kopachuck Master Plan will provide a long-term guide for development that meets the needs and desires of the public. The plan will also be in compliance with State Parks policies. The primary elements of the plan include:

- A) Upper Day Use Area
- B) New Kitchen/Shelter/Restroom
- C) Picnic Area
- D) Children's Play Area
- E) Outdoor Amphitheatre
- F) View Point and Beach Area
 - 1) new restrooms
 - 2) ADA-accessible viewing decks
 - 3) improved beach access
 - 4) additional mooring buoys
 - 5) relocated Cascadia Marine Trail campsite
- G) Loop Interpretive Trail System Improvements
 - 6) six (6) connected and improved loop trails with interpretive story points
 - 7) trail connection to Voyager Middle School
- H) Road and Parking Lot Improvements
 - 8) revised park entry/exit
 - 9) upper day use parking lot improvements
 - 10) welcome center/park office
 - 11) paved access to the beach use area
 - 12) six (6) car parking lot at the interpretive trail
- I) Forest Management Plan

12. Location of the proposal. Give sufficient information for a person to understand the precise location of your proposed project, including a street address, if any, and section, township, and range, if known. If a proposal would occur over a range of area, provide the range or boundaries of the site(s). Provide a legal description, site plan, vicinity map, and topographic map, if reasonably available. While you should submit any plans required by the agency, you are not required to duplicate maps or detailed plans submitted with any permit applications related to this checklist.

Kopachuck State Park is located just 5 miles west of Gig Harbor, Washington in Pierce County. The park is located within Section 16 of Township 21 North, Range 1E.

B. ENVIRONMENTAL ELEMENTS

1. Earth

- a. General description of the site:
Kopachuck State Park is divided roughly into two major areas – an upland portion and a lower portion – clearly defined by an abrupt edge or head scarp. The upper portion of the property is generally flat-lying with areas of gently undulating terrain.
- b. What is the steepest slope on the site (approximate percent slope)?
The steepest slope is 6-15%.
- c. What general types of soils are found on the site (for example, clay, sand, gravel, peat, muck)? If you know the classification of agricultural soils, specify them and note any prime farmland.
The northern portion of the park – including the parking lot, campground, and lower beach area – is mapped as Indianola loamy sand. The southern portion of the park – south of 56th Street NW – is mapped as Harstein gravelly, ashy, sandy loam. There are smaller areas, primarily in the southwest corner of the park, mapped as Kitsap silt loam.
- d. Are there surface indications or history of unstable soils in the immediate vicinity? If so, describe.
The land below the head scarp consists of hummocky terrain – sloping relatively gently – with native vegetation and a few trees – primarily alders – indicative of former landslide deposits below the head scarp. Many trees in this area, some as large as three feet in diameter, grow in bending or twisting fashion. This growth pattern, coupled with the size of the trees, suggests ongoing soil creep, yet no recent large-scale movement within the area below the head scarp is noted. The *Coastal Zone Atlas of Washington, Volume 7: Pierce County Coastal Zone Atlas* indicates that while the upland areas are stable, the area from the bluff or scarp is an unstable, older slide.
- e. Describe the purpose, type, and approximate quantities of any filling or grading proposed. Indicate source of fill.
Minor earthwork will be required in order to construct the plan as it has been developed. A fine import crushed rock will be used on the beach trail for drainage. There is a 2-3' high bank above the ordinary high water with wooden stairs to the beach. The proposal is to extend the scope of the gravel beach (approximately 4:1) landward to eliminate the stairs and provide direct pedestrian access to the beach. No filling will occur on the beach.
- f. Could erosion occur as a result of clearing, construction, or use? If so, generally describe.
Silt fencing and other BMPs will be required to prevent erosion.

- g. About what percent of the site will be covered with impervious surfaces after project construction (for example, asphalt or buildings)?
less than 1%

There will be a net reduction in existing impervious surfacing. The existing paved parking lot will be reduced by approximately 50%. While the proposed kitchen/shelter/restroom is larger than the existing restroom, there will be a net reduction in impervious areas.

- h. Proposed measures to reduce or control erosion, or other impacts to the earth, if any:
- 1) Builders will be required to implement a Storm Water Pollution Prevention (SWPPP) plan, which includes the use of temporary erosion controls, best management practices, and construction practices for controlling erosion. The plan would include: erecting silt fences; laying out a quarry spill construction entrance; and the use of sediment traps, storm sewer inlet protection, and measures for protecting disturbed soils.
 - 2) The SWPPP will be made part of the project bidding and construction documents.
 - 3) Upon completion of the project, the entire site will be completely stabilized around impervious surfaces (parking, walkways, and the building) using native plantings.
 - 4) Storage and spill control for diesel, lubricants, and oil will be covered by the project's Hazards Management Plan.

2. Air

- a. What types of emissions to the air would result from the proposal (i.e., dust, automobile, odors, industrial wood smoke) during construction and when the project is completed? If any, generally describe and give approximate quantities if known.

- 1) Vehicle and equipment emissions will occur during construction. Construction may be done in phases.
- 2) There may be dust in clearing and fill placement locations for about one month.

- b. Are there any off-site sources of emissions or odor that may affect your proposal? If so, generally describe.

None that are known of at this time

- c. Proposed measures to reduce or control emissions or other impacts to air, if any:

- 1) Vehicles and equipment are to be compliant with emissions regulations, turned off when not in use, and moved off site immediately when the earthwork is done.
- 2) Dust will be suppressed by spraying water and washing vehicle wheels according to the erosion control plan.
- 3) Any volatile fumes from asphalt paving will be minimized in accordance with the emissions management plan.

3. Water

- a. Surface:

- 1) Is there any surface water body on or in the immediate vicinity of the site (including year-round and seasonal streams, saltwater, lakes, ponds, wetlands)? If yes, describe type and provide names. If appropriate, state what stream or river it flows into.

Other than the saltwater shore of Colvos Passage, there are no year-round or seasonal streams. There are some wetted depressional areas that have not yet been delineated. There are drainages and depressions in the terrain but no streams. All potential wetland

trail crossings will require delineation and possible mitigation. Jurisdictional determination must be made by the ACOE.

- 2) Will the project require any work over, in, or adjacent to (within 200 feet) the described waters? If yes, please describe and attach available plans.

Improvements in the beach area, including extending the backshore area, will be within 200' of the Colvos Passage shoreline. Two mooring buoys will be added to the two existing buoys. The proposed trail routes will be delineated and the rating established. The square footage of the wetland areas is unknown at this time.

- 3) Estimate the amount of fill and dredge material that would be placed in or removed from surface water or wetlands and indicate the area of the site that would be affected. Indicate the source of fill material.

None: areas within wetlands will be bridged with a fiberglass grating deck.

- 4) Will the proposal require surface water withdrawals or diversions? Give general description, purpose, and approximate quantities if known.

Surface water runoff from the existing parking lot and roads will be redirected to rain gardens or a bioswale.

- 5) Does the proposal lie within a 100-year floodplain? If so, note location on the site plan.

No, the site does not lie within a 100-year floodplain.

- 6) Does the proposal involve any discharges of waste materials to surface waters? If so, describe the type of waste and anticipated volume of discharge.

none

b. Ground:

- 1) Will ground water be withdrawn, or will water be discharged to ground water? Give general description, purpose, and approximate quantities if known.

Ground water will not be withdrawn. Rainwater in all vegetated areas will continue to be allowed to infiltrate.

- 2) Describe waste material that will be discharged into the ground from septic tanks or other sources, if any (for example: Domestic sewage; industrial, containing the following chemicals; agricultural; etc.). Describe the general size of the system, the number of such systems, the number of houses to be served (if applicable), or the number of animals or humans the system(s) are expected to serve.

The existing drain field at the park entry will continue to be used.

c. Water runoff (including stormwater):

- 1) Describe the source of runoff (including storm water) and method of collection and disposal, if any (include quantities, if known). Where will this water flow? Will this water flow into other waters? If so, describe.

Surface runoff will be collected by catch basins and conveyed to a bioswale or rain gardens north of the parking lot via a pipe in the parking lot. From there, water will be piped to a point above the shoreline and allowed to dissipate via an overflow structure.

- 2) Could waste materials enter ground or surface waters? If so, generally describe.

No. Trash and debris will be collected and disposed of off site.

d. Proposed measures to reduce or control surface, ground, and runoff water impacts, if any:

- 1) Facility operations personnel will regularly remove trash and debris. Spill prevention provisions will be planned and practiced to keep pollutants away from contact with runoff.

- 2) The proposed onsite storm water system will have facilities to ensure that discharge water quality is in compliance with the all state and federal requirements.

4. Plants

- a. Types of vegetation found on the site:

Deciduous tree: big leaf maple, vine maple, alder

Evergreen tree: Douglas fir, western red cedar, hemlock, spruce

Shrubs: a variety of Northwest natives, including ferns, salmonberry, thimbleberry, Nootka rose

Grass: native and non-native grasses associated with western Washington coastal vegetation communities

Pasture: none

Crop or grain: none

Wet soil plants: typical native wetland plants

Water plants: none

Other types of vegetation: There are problems with invasive plant species in the park, particularly near trails and roads. Ivy poses the most serious problem at both Kopachuck and, more severely, at Cutts Island.

- b. What kind and amount of vegetation will be removed or altered?

Only vegetation under the building footprint will be removed (approximately 2,500 SF).

Approximately 60,000 SF of existing paving will be removed and those areas planted. All trails within wetlands will be on elevated fiberglass grating which will allow continuous light and rain penetration. No vegetation will be removed.

- c. List threatened or endangered species known to be on or near the site.

There are no known threatened or endangered species in or near the site.

- d. Proposed landscaping, use of native plants, or other measures to preserve or enhance vegetation on the site, if any:

All new planting will be with native plants.

5. Animals

- a. Birds and animals which have been observed on or near the site or are known to be on or near the site:

Birds: Bald eagle nests and a great blue heron colony have been documented in the vicinity of Kopachuck State Park, as well as a plethora of other bird species.

Mammals: deer, fox, raccoon, seals, and sea lions

Fish: salmon, shellfish

- b. List any threatened or endangered species known to be on or near the site.

The Washington Department of Fish and Wildlife (WDFW) Priority Habitats and Species Program (PHS) lists the following species and/or habitats within a 1.5 mile vicinity of the park:

1) great blue heron (*Ardea herodias*) – state-monitored species

2) harbor seal (*Phoca vitulina*) – state-monitored species; priority habitat listed as haul-out site where pupping occurs seasonally

3) bald eagle (*Haliaeetus leucocephalus*) – federal species of concern and state sensitive; within one mile of the park

c. Is the site part of a migration route? If so, explain.

The project site is located within the Pacific Flyway which is a flight corridor for migrating waterfowl and other avian fauna. The Pacific Flyway extends from Alaska to South America.

d. Proposed measures to preserve or enhance wildlife, if any:

Existing native vegetation will be retained. Supplemental native plantings will be added to the center of the parking lot. There will be no barriers to wildlife.

In 2009, the Classification and Management Planning (C.A.M.P.) project was undertaken by State Parks to determine whether Kopachuck could become consistent with the State Parks and Recreation Commission's vision for parks in the system. Those classifications and proposed facility developments that would allow higher recreation use have been applied in existing disturbed areas in such a manner as to avoid compromising the wildlife management of the park. Other proposed measures include continuing consultations with WDFW habitat biologists and implementing recommended management guidelines for priority species. In addition, State Parks will participate in site-specific restoration/enhancement projects/proposals. Development will be reviewed in consultation with WDFW when appropriate. Biological assessments will be conducted as required and potential mitigation measures will be identified for any listed species which could be affected by project actions. Additional baseline resource surveys, inventories, and monitoring will help guide park management activities through the further identification of sensitive species and priority habitats.

6. Energy and Natural Resources

a. What kinds of energy (electric, natural gas, oil, wood stove, solar) will be used to meet the completed project's energy needs? Describe whether it will be used for heating, manufacturing, etc.

Electric power will be used for site and building lighting.

b. Would your project affect the potential use of solar energy by adjacent properties? If so, generally describe.
No.

c. What kinds of energy conservation features are included in the plans of this proposal? List other proposed measures to reduce or control energy impacts, if any:

LED light fixtures will be used along the entry/exit roads and parking lot. Sustainable building materials, recycled materials, and waste management are key considerations and requirements of the project.

7. Environmental Health

a. Are there any environmental health hazards, including exposure to toxic chemicals, risk of fire and explosion, spill, or hazardous waste, that could occur as a result of this proposal? If so, describe.

- 1) Diesel or oil spill associated with construction equipment.
- 2) Miscellaneous industrial chemicals used during construction.
- 3) Airborne construction dust containing irritants.

1) Describe special emergency services that might be required.

- A) Medic services for potential serious injuries.

B) Petroleum and chemical spills would be small because of small amounts stored on site; such will be handled by the contractor's work force.

2) Proposed measures to reduce or control environmental health hazards, if any:

- A) Petroleum spill prevention and cleanup provisions will govern the project.
- B) Workers will be educated about MSDS data for industrial chemical use.
- C) Daily cleanup and dust suppression will govern the project.
- D) Fire prevention and safety procedures will govern the project.

b. Noise

1) What types of noise exist in the area which may affect your project (for example: traffic, equipment, operation, other)?

Only sounds of nature are audible on site.

2) What types and levels of noise would be created by or associated with the project on a short-term or a long-term basis (for example: traffic, construction, operation, other)? Indicate what hours noise would come from the site.

- 1) Short Term: construction equipment operation noises up to 80dBA from 7:00 AM to 4:30 PM on week days.
- 2) Long Term: outside activities related to picnicking.

3) Proposed measures to reduce or control noise impacts, if any:

- 1) Minimize the operation of construction equipment by bundling noisy activities.

8. Land and Shoreline Use

a. What is the current use of the site and adjacent properties?

The site is a day use facility for picnicking- and beach-related activities. Adjacent properties are some distance away and are residential. A middle school and elementary school are to the east.

b. Has the site been used for agriculture? If so, describe.

No.

c. Describe any structures on the site.

There are three existing wood and masonry restroom structures, all three of which are scheduled for removal as part of the proposed improvements. One precast restroom, approximately 2,500 SF, will be retained. There are four open-sided shelters, approximately 16'x20', which will be retained and/or relocated on site. There is an existing park ranger residence and shop at the southeast corner of the property.

d. Will any structures be demolished? If so, what?

Yes. The three existing restrooms will be demolished. One precast concrete restroom will be retained.

e. What is the current zoning classification of the site?

R-10

f. What is the current comprehensive plan designation of the site?

Currently, the comprehensive plan designation is "Park."

- g. If applicable, what is the current shoreline master program designation of the site?
conservancy
- h. Has any part of the site been classified as an "environmentally sensitive" area? If so, specify.
There are county-designated critical wetland areas.
- i. Approximately how many people would reside or work in the completed project?
There is one permanent park ranger residing at the park's ranger residence. Future improvements may result in a minor increase in park staff.
- j. Approximately how many people would the completed project displace?
none
- k. Proposed measures to avoid or reduce displacement impacts, if any:
none required
- l. Proposed measures to ensure the proposal is compatible with existing and projected land uses and plans, if any:
A pre-submittal meeting was conducted with Pierce County staff. They indicated that the proposal appears to be compatible with the existing and projected land uses and plans.

9. Housing

- a. Approximately how many units would be provided, if any? Indicate whether high, middle, or low-income housing.
No additional housing units will be part of the proposal.
- b. Approximately how many units, if any, would be eliminated? Indicate whether high, middle, or low-income housing.
No housing will be eliminated.
- c. Proposed measures to reduce or control housing impacts, if any:
none required

10. Aesthetics

- a. What is the tallest height of any proposed structure(s), not including antennas; what is the principal exterior building material(s) proposed?
The tallest height of the kitchen/shelter/restroom is approximately 24 feet. The principal exterior building material will be wood.
- b. What views in the immediate vicinity would be altered or obstructed?
No views will be altered.
- c. Proposed measures to reduce or control aesthetic impacts, if any:
All new buildings will have the same Cascadian Northwest architectural character. New site furnishings such as rails and benches will be of the same architectural character. Design standards are part of the proposal in order to maintain architectural quality and character in any remedial work that may be required in the future or done by volunteers.

11. Light and glare

- a. What type of light or glare will the proposal produce? What time of day would it mainly occur?
Exterior security lighting and parking lot lighting will utilize state of the art LED lights.

b. Could light or glare from the finished project be a safety hazard or interfere with views?

No.

c. What existing off-site sources of light or glare may affect your proposal?

none

d. Proposed measures to reduce or control light and glare impacts, if any:

none required

12. Recreation

a. What designated and informal recreational opportunities are in the immediate vicinity?

The site currently serves as a day use facility for hiking, picnicking, and beach-related activities.

b. Would the proposed project displace any existing recreational uses? If so, describe.

No. In fact, the intent of the project is to enhance the day use facilities and capabilities of the site. The improvements will also provide ADA access to the beach area, to viewing platforms, and to the shoreline itself. Access to the picnic area and kitchen/shelter/restroom will also be ADA-compliant.

c. Proposed measures to reduce or control impacts on recreation, including recreation opportunities to be provided by the project or applicant, if any:

The fully realized plan will greatly enhance recreation opportunities for citizens of Washington State. The purpose of the proposal is to allow for and enhance, in balance with natural and cultural stewardship responsibilities, appropriate recreational values.

13. Historic and cultural preservation

a. Are there any places or objects listed on, or proposed for, national, state, or local preservation registers known to be on or next to the site? If so, generally describe.

Records on file at State Parks and the Department of Archeology and Historic Preservation (DAHP) indicate that archeological sites and historic properties exist at Cutts Island.

b. Generally describe any landmarks or evidence of historic, archaeological, scientific, or cultural importance known to be on or next to the site.

Cutts Island is known to have been a burial site for local Native American tribes. It is also rumored to have been a stopping point for Peter Puget during his exploration of the area.

c. Proposed measures to reduce or control impacts, if any:

In compliance with Chapter 27.44 RCW, Chapter 27.53 RCW, and DAHP rules and regulations, contract specifications for proposed improvements will contain provisions for the protection of cultural resources. Overnight use of Cutts Island, as well as campfires and the removal of any vegetation in the park, is prohibited.

14. Transportation

a. Identify public streets and highways serving the site, and describe proposed access to the existing street system.

Show on site plans, if any.

Vehicle access is from Kopachuck Drive NW to 56th Street NW. These are both Pierce County Roads.

- b. Is site currently served by public transit? If not, what is the approximate distance to the nearest transit stop?
No, and there are no plans by Pierce Transit to provide public transit to the site.
- c. How many parking spaces would the completed project have? How many would the project eliminate?
105 parking spaces will be provided. There are approximately 150 available spaces now. The majority of the parking lot has been closed for some time.
- d. Will the proposal require any new roads or streets, or improvements to existing roads or streets, not including driveways? If so, generally describe (indicate whether public or private).
No new roads or streets will be added; however, the existing entrance and exits roads will both be resurfaced as part of the improvements. The beach access road will also be paved. It is not anticipated that improvements will generate any new vehicular trips.
- e. Will the project use (or occur in the immediate vicinity of) water, rail, or air transportation? If so, generally describe.
No.
- f. How many vehicular trips per day would be generated by the completed project? If known, indicate when peak volumes would occur.
Park capacity will not change.
- g. Proposed measures to reduce or control transportation impacts, if any:
The existing entrance road and exit road are being switched in order to make park access and parking lot circulation more efficient.

15. Public Services

- a. Would the project result in an increased need for public services (for example: fire protection, police protection, health care, schools, other)? If so, generally describe.
This project is intended to address the demand for public recreation services. There will be no increased demand for water or power other than what is required to light the parking lot and entrance and exit roads.
- b. Proposed measures to reduce or control direct impacts on public services, if any.
The addition of security cameras and the ability for park rangers to operate gates remotely will enhance site security. In the past, the only police calls to the site regarded car prowls. The addition of security cameras and a staffed welcome center at the entrance to the parking lot will reduce the potential for vandalism or theft. The beach area access road will be controlled by remotely-operable gates. There will be a hammerhead turnaround for emergency vehicles at the beach area.

16. Utilities

- a. Circle utilities currently available at the site: electricity, natural gas, water, refuse service, telephone
Other utilities include: storm water and data/cable/internet
- b. Describe the utilities that are proposed for the project, the utility providing the service, and the general construction activities on the site or in the immediate vicinity which might be needed.
- 1) Electricity is provided by Peninsula Light Company.
 - 2) Sanitary sewer will utilize the existing or possibly modified drain field.

- 3) Water service is from the existing onsite well near the ranger residence. New water lines will be included as part of the park project.

C. SIGNATURE

The above answers are true and complete to the best of my knowledge. I understand that the lead agency is relying on them to make its decision.

Signature: Ben G. [Signature]

Date Submitted: 6/17/14

Attachment 2

Inadvertent Discovery Plan (IDP) – Cultural Resources

Kopachuck State Park

Inadvertent Discoveries of Cultural Resources and Human Skeletal Remains

Many of Washington's most important heritage sites reside on lands owned or managed by the Washington State Parks and Recreation Commission (WSPRC). Nearly all Washington State Parks contain one or more important historic buildings, structures, or archaeological sites. For this reason, archaeological surveys and historic building inventories are ordinarily commissioned as a part of background analysis and information gathering for park developments and undertakings. Results of these surveys are used during project planning to ensure every effort is made to avoid impacts to cultural resources. Yet, despite these efforts, there **always** remains some potential for unanticipated discoveries while working in Washington State Parks.

All unanticipated discoveries, both cultural resources and human skeletal remains, are subject to all applicable federal and state statutes, regulations, and executive orders. For these reasons, the Inadvertent Discovery Plan (IDP) provides useful guidance and instructions for circumstances when cultural resources or human skeletal remains are found. Please carefully read these instructions. If you have any questions, please contact the appropriate WSPRC Area Manager or the WSPRC archaeologist assigned to the undertaking. It is also strongly recommended that anyone conducting ground-disturbing activities watch the training video produced by Washington State Dept of Ecology: [Inadvertent Discovery of Cultural Resources or Human Remains: Training for Field Staff](#). This IDP for cultural resources and human skeletal remains is based on [RCW 27.53](#), [RCW 68.50.645](#), [RCW 27.44.055](#), and [RCW 68.60.055](#) and [recommended language](#) from the Department of Archaeology and Historic Preservation (DAHP).

INADVERTENT DISCOVERY PLAN FOR CULTURAL RESOURCES

If cultural resources are found during a project, activity in the immediate area of the find should be discontinued (**stop**), the area secured (**protect**), and the WSPRC archaeologists notified to assess the find (**notify**). ***When in doubt, assume the material is a cultural resource and implement the IDP outlined below.***

Recognizing Cultural Resources-Types of Historic/Prehistoric Artifacts and/or Activity Areas That May Be Found

- **Artifacts-** Both historic and prehistoric artifacts may be found exposed in backhoe trenches or back dirt piles.
 - Prehistoric artifacts may range from finished tools such as stone pestles, arrowheads/projectile points, shell beads, or polished bone tools to small pieces or "flakes" or "chips" of exotic stone such as chert, jasper, or obsidian.
 - Historic artifacts may include older (more than 50 years) nails, plates/ceramics, bottles, cans, coins, glass insulators, or bricks.
 - Old abandoned industrial materials from farming, logging, railways, lighthouses, and military installations.
- **Activity Area/Cultural Features-** While excavating trench lines look for evidence of buried activity areas/cultural features such as old campfire hearths or buried artifacts.
 - An area of charcoal or very dark stained soil with artifacts or burned rocks may be a fire hearth.
 - A concentration of shell with or without artifacts may be shell midden deposits.
 - Modified or stripped trees, often cedar or aspen, or other modified natural features, such as rock drawings or carvings
- **Historic building foundation/structural remains-** During excavation, buried historic structures (e.g., privies, building foundations) that are more than 50 years old may be found.
- **Bone-** Complete or broken pieces of bones may be discovered exposed in trench walls or in back dirt piles. Bone of recent age is usually transparent or white in color. Older bone is

usually found in various shades of brown. Burned bone is usually black or, if heavily burned, bluish-white.

Steps to Take If a Cultural Resource Is Found During Construction

1. **Stop** if a cultural resource(s) is observed or suspected, all work within the immediate area of the discovery must stop.
2. **Protect** the area from further disturbance. Do not touch, move, or further disturb the exposed materials/artifacts. Create a protected area with temporary fencing, flagging, stakes, or other clear markings that is large enough (30 feet or larger) to protect the discovery location area. The WSPRC archaeologist can help determine the size of the protected area. Do not permit vehicles, equipment, or unauthorized personnel to traverse the discovery site.
3. **Notify** the WSPRC archaeologist. If the area needs to be secured, notify the Park Ranger or Park staff as well.
4. If requested by the WSPRC archaeologist, take photographs with a scale (e.g., pen, coin, etc.) and collect geospatial information of the discovery site to document the initial finds.

What Not to Do If a Cultural Resource Is Found During Construction

- Do not remove any artifacts from the site of the discovery.
- Do not dig out objects protruding from any trench walls as this may cause further damage to artifacts and/or destroy important contextual information.
- Do not share any information about the find, including on social media, except as necessary to implement the IDP.

What Happens Next?

1. The find will be assessed by a professional archaeologist (may be a WSPRC archaeologist or an archaeology consultant).
 - a. If the find is not a cultural resource, construction work may resume.
 - b. If the find is a cultural resource, the WSPRC archaeologist will contact the DAHP and affected Tribes, as appropriate, to develop a suitable treatment plan for the resource.
2. Construction work may resume in the protected area after the WSPRC archaeologist assigned to the undertaking has determined that the find has been adequately investigated and, if necessary, a treatment plan and monitor are in place to protect any remaining archaeological deposits.

INADVERTENT DISCOVERY PLAN FOR HUMAN SKELETAL REMAINS

Native American burials and historic grave sites are uncommon features on Washington State Park lands. These remains, as well as any associated artifacts or funerary objects, are protected under state law and, if the park is a federal lease, applicable federal law. If you discover human remains (or bones that you believe may be human remains) during construction, please follow these important instructions. It is imperative that reporting and treatment of any human remains found during construction or any ground-disturbing activities are treated with utmost dignity and respect.

Steps to Take If Human Skeletal Remains are Found During Construction

1. **Stop** if human skeletal remains observed or suspected, all work within the immediate area of the discovery must stop.
2. **Protect** the area from further disturbance. Do not touch, move, or further disturb the remains. Cover the remains with a tarp or other materials (not soil or rocks) for temporary protection in place and shield them from being photographed. Create a protected area with temporary fencing, flagging, stakes, or other clear markings that is large enough (30 feet or larger) to protect the discovery location area. The WSPRC archaeologist can help determine the size of the protected area. Do not permit vehicles, equipment, or unauthorized personnel to traverse the discovery site.

3. **Notify** law enforcement and the appropriate county medical examiner/coroner as soon as possible. If you are unsure if the remains are human, the physical anthropologist at DAHP may be called. Also notify the Park Ranger, the WSPRC archaeologist, and the WSPRC Curator of Collections/NAGRPA Specialist of the discovery of the remains.
4. If requested by the law enforcement, the county coroner/examiner, the DAHP physical anthropologist, or the WSPRC archaeologist, take photographs with a scale (e.g., pen, coin, etc.) and geospatial information of the discovery site to document the initial finds.

What Not to Do If Human Skeletal Remains are Found During Construction

- Do not pick up or remove anything.
- Do not take any photographs of the remains unless instructed to do so by law enforcement, the county coroner/examiner, the DAHP physical anthropologist, or the WSPRC archaeologist. If pictures are requested, be prepared to photograph them with a scale (e.g., pen, coin, etc.) and collect geospatial information of the remains.
- Do not call 911 unless you cannot reach law enforcement or the coroner/examiner by other means.
- Do not share any information about the find, including on social media, except as necessary to implement the IDP.

What Happens Next?

1. The county medical examiner/coroner will assume jurisdiction over the human skeletal remains and decide whether those remains are forensic (crime-related) or non-forensic.
 - a. If forensic, the county medical examiner/coroner will retain jurisdiction over the remains.
 - b. If non-forensic, the county medical examiner/coroner will report that finding to the DAHP who will then take jurisdiction over the remains. The DAHP will notify any appropriate cemeteries and all affected Tribes of the remains. The State Physical Anthropologist will decide whether the remains are Indian or Non-Indian and report that finding to any appropriate cemeteries and the affected Tribes. The DAHP will then handle all consultation with the affected parties as to the future preservation, excavation, and disposition of the remains.
 Note: The WSPRC archaeologist assigned to the undertaking will be coordinating and consulting with the DAHP, affected Tribes, and other groups as necessary. Additionally, WSPRC's Curator of Collections/NAGPRA Specialist should be included on all written and/or verbal correspondence until the remains have been officially transferred from WSPRC's possession to an outside authority. Until the remains are transferred off of WSPRC's property, it is the responsibility of the Curator of Collections/NAGPRA Specialist to document and track the information regarding all human remains and associated funerary objects (including all material from excavation areas/units from which the human remains were removed).
2. Construction work may resume in the protected area after the WSPRC archaeologist assigned to the undertaking has determined that the find has been adequately investigated and, if necessary, a treatment plan and monitor are in place.

EMERGENCY CONTACTS

WSPRC Archaeologists

Jennifer Wilson, Archaeology Program Manager	(360) 787-6511 (cell)
Shari Silverman, Archaeologist	(435) 260-9894 (cell)

WSPRC Curator of Collections/NAGPRA Specialist

Alicia L. Woods, Statewide Curator of Collections & NAGPRA Specialist	(360) 586-0206 (office)
---	-------------------------

State Physical Anthropologist

Guy Tasa, PhD, Dept. of Archaeology and Historic Preservation	(360) 790-1633 (cell)
---	-----------------------

Assistant State Physical Anthropologist

Alex Garcia-Putnam, Dept. of Archaeology and Historic Preservation (360) 890-2633 (cell)

Local Law Enforcement

Ranger Olyvia Buday (Assistant South Sound Area Manager; Penrose State Park): Kopachuck State Park is within the South Sound Area and Ranger Buday is located at Penrose Point State Park, so that is the office phone below).

(360) 867-8243 (work cell)
(253) 884-2514 (park office)

Pierce County Medical Examiner:

Karen Cline-Parhamovich, DO (Chief Medical Examiner) (253) 798-6494

Area Manager

Joel Pillers, Area Manager, South Sound Area (360) 640-4425 (cell)

Attachment 3

DAHP Letter



Allyson Brooks Ph.D., Director
State Historic Preservation Officer

April 22, 2019

Ms. Shari Maria Silverman
Washington State Parks & Recreation Commission
1111 Israel Road SW
PO Box 42650
Olympia, Washington 98504-2650

Re: Day Use Area Development Project
Log No.: 2018-12-09548-WSPRC

Dear Ms. Silverman:

Thank you for contacting our department pursuant to Executive Order 05-05. We have reviewed the professional archaeological survey report you provided for the proposed Day Use Area Development Project at Kopachuck State Park, Pierce County, Washington.

We concur with the determination of no cultural resource impacts with the stipulation for an unanticipated discovery plan.

We would appreciate receiving any correspondence or comments from concerned tribes or other parties that you receive.

In the event that archaeological or historic materials are discovered during project activities, work in the immediate vicinity must stop, the area secured, and this department and the consulted tribes notified.

These comments are based on the information available at the time of this review and on behalf of the State Historic Preservation Officer in compliance with Executive Order 05-05. Should additional information become available, our assessment may be revised, including information regarding historic properties that have not yet been identified. Thank you for the opportunity to comment and a copy of these comments should be included in subsequent environmental documents.

Sincerely,

A handwritten signature in blue ink, appearing to read 'Rob Whitlam', followed by a long horizontal line.

Robert G. Whitlam, Ph.D.
State Archaeologist
(360) 586-3080
email: rob.whitlam@dahp.wa.gov



Attachment 4

Shoreline Substantial Development, Conditional Use, & Variance Permit



Pierce County

Office of the Pierce County Hearing Examiner

2401 South 35th Street, Room 2
Tacoma, Washington 98409-7460
(253) 798-7113

STEPHEN K. CAUSSEAU, JR.
Pierce County Hearing Examiner

February 16, 2023

Washington State Parks and Recreation Commission
Attn: Jessica Norton
P.O. Box 42650
Olympia, WA 98504

**RE: ONE YEAR TIME EXTENSION FOR:
SHORELINE SUBSTANTIAL DEVELOPMENT/SHORELINE VARIANCE/
CONDITIONAL USE OF KOPACHUCK STATE PARK DAY USE AREA
Application Numbers: 1004188, 906881, 906883, 906884, 908629**

Dear Applicant:

Transmitted herewith is the Report and Decision of the Pierce County Hearing Examiner regarding your request for the above-entitled matter.

Very truly yours,

A handwritten signature in blue ink, appearing to read "SKC", written over a blue horizontal line.

STEPHEN K. CAUSSEAU, JR.
Hearing Examiner

SKC/jjp
cc: Parties of Record

OFFICE OF THE HEARING EXAMINER

PIERCE COUNTY

REPORT AND DECISION

**TIME EXTENSION FOR: ONE YEAR TIME EXTENSION FOR:
SHORELINE SUBSTANTIAL DEVELOPMENT/
SHORELINE VARIANCE/CONDITIONAL USE OF
KOPACHUCK STATE PARK DAY USE AREA
Application Numbers: 1004188, 906881, 906883,
906884, 908629**

SUMMARY OF REQUEST:

Request for a one-year time extension for the shoreline substantial development permit, shoreline variance, and shoreline conditional use permit for the Kopachuck State Park day use area.

SUMMARY OF DECISION:

Time extension is hereby granted.

FINDINGS AND DECISION:

FINDINGS:

1. By Report and Decision dated September 24, 2020, Deputy Hearing Examiner Michael M. McCarthy conditionally approved a shoreline substantial development permit, shoreline variance, and shoreline conditional use permit to allow improvements to the Kopachuck State Park. The applicant, Washington State Parks and Recreation Commission timely submitted an email request for a one-year extension on October 28, 2022, to Pierce County Planning and Public Works. However, the request was not formally submitted to the County until January 20, 2023.
2. According to a letter from Mr. Robert Perez the County previously accepted the applicant's building permits related to Phase 1 and is proceeding towards issuance. Phase 1 includes the stormwater systems, reconstruction of the upper parking lot and access, new day use buildings, welcome center, ADA accessible picnic area, amphitheater, and play areas. However, the applicant has not submitted development applications or building permit applications for Phase 2.

3. Staff agrees that the applicant has made significant progress in the development of the project and recommends approval of a one-year time extension.
4. Mr. Robert Perez's letter dated February 7, 2023, is incorporated herein by this reference as if set forth in full. Based upon the contents said letter, the request for a one-year time extension is in accordance with conditions of approval imposed by Deputy Examiner McCarthy.
5. The new expiration date is **November 16, 2023**.

DECISION:

The request for a one-year time extension for the shoreline substantial development permit, shoreline variance, and shoreline conditional use permit for the Kopachuck State Park day use area is hereby granted.

ORDERED this 16th day of February, 2023.



STEPHEN K. CAUSSEAU, JR.
Hearing Examiner

TRANSMITTED this 16th day of February, 2023, to the following:

APPLICANT: Washington State Parks and Recreation Commission
Attn: Jessica Norton
P.O. Box 42650
Olympia, WA 98504
jessica.norton@parks.wa.gov

OTHERS:

Thomas Rafoth
11220-56th Street N.W.
Gig Harbor, WA 98335

Drs. Ulf and Shema Hanebutte
11006-56th Street N.W.
Gig Harbor, WA 98335

Michael and Jackie Murphy
11030-56th Street N.W.
Gig Harbor, WA 98335

Lynda Filson
4916-101st Avenue Court N.W.
Gig Harbor, WA 98335

Ben and Susan Paganelli
5125-105th Avenue Court N.W.
Gig Harbor, WA 98335

Charles and Charlene Severin
11024-54th Street N.W.
Gig Harbor, WA 98335

Pat Baxter
11004-54th Street Court N.W.
Gig Harbor, WA 98335

Scott and Rochelle Huntington
11011-54th Street Court N.W.
Gig Harbor, WA 98335

Marty and Candance Behtrott
11016-54th Street Court N.W.
Gig Harbor, WA 98335

David Stuyvenberg
11022-56th Street N.W.
Gig Harbor, WA 98335

Bonnie Daybell
11007-56th Street Court N.W.
Gig Harbor, WA 98335

Scott and Jennifer Sadlier
11108-54th Street N.W.
Gig Harbor, WA 98335

Gig Harbor Peninsula Advisory Commission (PAC)

PIERCE COUNTY LAND USE AND ENVIRONMENTAL REVIEW
PIERCE COUNTY DEVELOPMENT ENGINEERING
PIERCE COUNTY FIRE PREVENTION BUREAU
PIERCE COUNTY PARKS AND RECREATION
PIERCE COUNTY CODE ENFORCEMENT
PIERCE COUNTY BUILDING DIVISION
PIERCE COUNTY CARTOGRAPHY
PIERCE COUNTY UTILITIES
PIERCE COUNTY COUNCIL
TACOMA-PIERCE COUNTY HEALTH DEPARTMENT

**CASE NO.: ONE YEAR TIME EXTENSION FOR:
SHORELINE SUBSTANTIAL DEVELOPMENT/SHORELINE VARIANCE/
CONDITIONAL USE OF KOPACHUCK STATE PARK DAY USE AREA
Application Numbers: 1004188, 906881, 906883, 906884, 908629**

NOTICE

1. RECONSIDERATION:

Any aggrieved party or person affected by the decision of the Examiner may file with the Department of Planning and Land Services a written request for reconsideration including appropriate filing fees within seven (7) working days in accordance with the requirements set forth in Section 1.22.130 of the Pierce County Code.

2. APPEAL OF EXAMINER'S DECISION:

The final decision by the Examiner may be appealed in accordance with Ch. 36.70C RCW.

NOTE: In an effort to avoid confusion at the time of filing a request for reconsideration, please attach this page to the request for reconsideration.



STATE OF WASHINGTON
DEPARTMENT OF ECOLOGY

PO Box 47775 • Olympia, Washington 98504-7775 • (360) 407-6300
711 for Washington Relay Service • Persons with a speech disability can call 877-833-6341

November 16, 2020

Jessica Norton
WA State Parks and Recreation Commission
PO Box 42650
Olympia, WA 98504

Re: Pierce County Local Permit 906881
Jessica Norton, WA State Parks and Recreation Commission - Applicant
Approved Shoreline Variance Permit 736

Dear Jessica Norton:

On October 8, 2020, the Department of Ecology (Ecology) received the Pierce County decision on your Shoreline Variance Permit for stormwater improvements within the shoreline buffer at Kopachuck State Park. The overall project will renovate and expand the day-use area of Kopachuck State Park. Elements include new kitchen and picnic shelters, ADA-compliant trails and picnic areas, improved access to the water, playground equipment, interpretive signs, replacing an antiquated restroom, and parking lot improvements, which include new pavement, stormwater improvements, striping, bumper blocks, and bike racks.

By law, Ecology must review Variance Permits for compliance with:

- The Shoreline Management Act (Chapter 90.58 RCW)
- Ecology's Variance Permit approval criteria (Chapter 173-27-170 WAC)
- The Pierce County Local Shoreline Master Program

After reviewing Variance Permits for compliance, Ecology must decide whether to approve, approve with conditions, or disapprove them.

Our Decision:

Ecology approves your Variance Permit provided your project complies with the conditions required by Pierce County. **Please note, however, that other federal, state, and local permits may be required in addition to this shoreline permit.**

What Happens Next?

Before you begin activities authorized by this permit, the law requires you to wait at least 21 days from the date of this letter, the "date of filing". This waiting period allows anyone (including you) who disagrees with any aspect of this permit, to appeal the decision to the state Shorelines Hearings Board.

Jessica Norton
November 16, 2020
2 of 2

You must wait for the conclusion of an appeal before you can begin the activities authorized by this permit.

We recommend contacting the Shorelines Hearings Board at (360) 664-9160 before beginning permit activities to ensure that no appeal has been filed. Information on appeals is also posted at http://www.eluho.wa.gov/Decision/Search_Cases. Select "Shorelines Hearings Board" from the drop down menu labeled "Board" and enter "Search." The most current appeal will appear on top.

If **you** want to appeal this decision, you can find appeal instructions (Chapter 461-08 WAC) at the Shorelines Hearings Board website above. They are also posted on the website of the Washington State Legislature at: <http://apps.leg.wa.gov/wac>.

If you have any questions, please contact Zach Meyer at (360) 407-6167.

Sincerely,



Perry J Lund, Section Manager
Shorelands and Environmental Assistance Program

cc: Robert Perez, Pierce County

Staff Report

Shoreline Substantial Development Permit/Shoreline Variance/Conditional Use Permit/Environmental Checklist: Kopachuck State Park Day Use Development Application Numbers: 906881, 906883, 908629, 906884 Parcel Number: 0121161010

Examiner’s Hearing: Wednesday, August 26, 2020 at 10:00 a.m.

Due to COVID-19 restrictions on gatherings, this hearing will be held remotely. To participate in the remote hearing, or to find out if room capacity is available, please contact Stacy Weaver at stacy.manthou@piercecountywa.gov or at (252) 798-3292, for instructions.

Proposal: This project will renovate and expand the day-use area of Kopachuck State Park. Elements include new kitchen and picnic shelters, ADA-compliant trails and picnic areas, improved access to the water, playground equipment, interpretive signs, replacing an antiquated restroom, and parking lot improvements, which include new pavement, stormwater improvements, striping, bumper blocks and bike racks. This will be a phased project, portions of which take place outside the shoreline jurisdiction. Phase one consists of the stormwater system, reconstructing upper parking lot and entry and exit roads, new day use buildings, a welcome center, ADA-accessible picnic area, amphitheater and play areas. Phase two originally included a pocket beach to be installed but this was removed from the overall proposal to minimize impacts. ADA pathways are still part of the overall proposal.

Project Location: The site is in the Park and Recreation (PR) zone classification and Conservancy Shoreline Environment, within the Gig Harbor Community Plan area, located at 11101 56th Street NW, Gig Harbor, WA 98335, in the Section 16, Township 21N, Range 01, W.M., in Council District # 7.

Staff Recommendation: County Staff has reviewed this proposal for compliance with all applicable policies, codes, and regulations. The County recommends Approval of the proposed Shoreline Substantial Development Permit, Shoreline Variance, and Conditional Use Permit subject to regulatory requirements and recommended conditions of approval.

State Environmental Policy Act (SEPA): A SEPA checklist was submitted for this application. Planning and Public Works (PPW) has concluded that the previously approved Determination of Nonsignificance, dated June 27, 2014, and associated addendum, are sufficient for this proposal. The County is not assuming lead agency and supports the DNS and associated addendum.

County Contact: Robert Perez, Planner, 253-798-3093, robert.perez@piercecountywa.gov

Pierce County Online Permit Information:

<https://pals.piercecountywa.gov/palsonline/#/permitSearch/permit/departmentsStatus?applPermitId=906881>



Project Data

Application Complete Date: March 26, 2019

LUAC Meeting Date: May 22, 2019

Staff Report Mailed Date: August 19, 2020

Applicant/Agent: Washington State Parks and Recreation Commission
P.O. Box 42650
Olympia, WA 98504
Jessica.norton@parks.wa.gov

Legal and Public Notice

- *April 3, 2019*: Notice of Application and Public Meeting Notice was sent to property owners within a radius of 300 feet, but not less than two parcels deep, around the exterior boundaries of the site.
- *April 13, 2019*: The site was posted with a Public Notice sign and confirmed with a Declaration of Posting.
- *May 8, 2019, and May 9, 2019*: Legal Notices were published in the official County newspaper (*Tacoma News Tribune*), and the *Peninsula Gateway* newspaper advertising the public meeting to be held by the Gig Harbor Peninsula Advisory Commission.
- *August 11, 2020*: Public Notice of the Examiner's Hearing was sent to property owners within a radius of 300 feet, but not less than two parcels deep, around the exterior boundaries of the site.
- *August 12, 2020, and August 13, 2020*: Legal notices were published in the official County newspaper (*Tacoma News Tribune*) and the *Peninsula Gateway* newspaper, advertising the hearing to be held by the Pierce County Hearing Examiner.

Ortho Photo



Site Plan / Day Use Area



- The Washington State Parks and Recreation Commission issued a SEPA “Determination of Non-Significance” (DNS) on October 3, 2011, for a proposed Kopachuck State Park Hazard Tree Removal Project, which involved the harvest of approximately 900 trees in a 50-acre portion of the park.
- In 2017, landslide and erosion activity were identified in the area.
- A Customer Information Meeting was conducted under permit number 899089, on December 6, 2018. The Customer Information Meeting covered many of the 18J requirements as well as the requirements of 18S.

Site Characteristics

- The County Assessor lists parcel 0121161010 as being 107.4 acres in size.
- The parcel is accessed from the south via 56th Street NW.
- The parcel is located on the east shore of Carr Inlet.
- The topography of the site slopes toward the shore.
- The parcel is improved with several park’s facilities and trails.
- The parcel is heavily vegetated throughout the majority of the site.
- The parcel’s upland portion contains parking, trails, restrooms, and signage.
- The parcel’s shoreline portion currently contains a network of earthen trails, benches, shoreline viewing areas, and some largely undisturbed shorelines.

Surrounding Land Use/ Zoning Designation

LAND USE		ZONING
North	Single Family Residence	Rural 10 (R10)
South	Single Family Residence	R10
East	Elementary School	R10
West	Puget Sound	R10

Gig Harbor Peninsula Advisory Commission

The Gig Harbor Peninsula Advisory Commission (PAC) heard the matter at its regularly scheduled meeting on May 22, 2019. Eight members were in attendance. A quorum of members was present. Robert Perez made a presentation and answered questions.

Bruce Dees/Landscape Architect

- He has been working on various portions of the project since 2014.
- He is aware of the requirements for pervious materials within the shoreline jurisdiction.
- Presented proposed plans to address the pervious surface requirements.
- The access roadway coming down to the shoreline would remain impervious surface. (This road is outside of the shoreline jurisdiction.)

Seven members of the public spoke.

- Fear of landslide if more people used the park, and congestion of facilities.
- Belief that proposal is only to generate revenue.
- Handicapped people can’t use the beach.
- Current paths and trails can’t be maintained.
- A day use area shouldn’t be part of this proposal.

- Erosion hazards from previous tree removal.
- ADA compliance is needed at this park.
- Concerns over the amount of water coming down to beach.
- Security concerns as the gate is often left open and unlocked after dark.
- Concerns over increased trash and increased use from people.

A motion was made by James Peschek and seconded by Gordon Ballantyne to recommend approval of the proposal with the following conditions:

- That the County look at an alternate design for the impervious ADA access pathways so the State does not incur more costs for equipment to vacuum out pervious pavers and maintain pervious pathways.

The motion passed by a vote of 8 yes and 0 no.

Governing Regulations

The proposal has been reviewed for conformance with the following goals, policies and requirements in effect on the complete application date of this proposal (include amended dates):

- Title 19A Comprehensive Plan - January 1, 1995, as amended
- Title 17A Construction and Infrastructure Regulations – Site Development and Stormwater Drainage
- Title 17B Construction and Infrastructure Regulations – Road and Bridge Design and Construction Standards
- Title 18 Development Regulations - General Provisions
- Title 18A Development Regulations – Zoning
- Title 18F Development Regulations - Land Division and Boundary Changes
- Title 18J Design Standards and Guidelines

Planning and Public Works Staff Review for Consistency with Regulations and Policies

Gig Harbor Peninsula Community Plan (Pierce County Code, Title 19B)

- Provide adequate park and recreational facilities within the community plan area that satisfy the highest standards for environmental protection while meeting the needs of Peninsula residents.
- Provide and maintain a level of service for regional parks in the community that meets or exceeds the countywide standard.
- Parks that provide shoreline access are considered regional parks regardless of size.
- Provide development incentives such as bonus densities and increased impervious coverage for projects that incorporate trails into the project site plan.
- Encourage acquisition of shoreline access points that provide opportunities for boat launches, public docks or piers, beach walking, wildlife viewing and other shoreline dependent uses.

Staff Comment: This proposal is consistent with the Gig Harbor Peninsula Community Plan policies. The proposal aims to increase ADA accessibility creating more opportunity for the public to access the shoreline environment.

Pierce County Development Regulations - Zoning (Title 18A)

18A.23 Gig Harbor Peninsula Use Table

Zoning is Park and Recreation (PR) and the Civic Use Category is for Public Park Facilities is C3 which requires a conditional use permit for new park facilities.

Public Park Facilities Use Type refers to publicly owned or non-profit recreational areas and recreation facilities open to the general public on an equal basis, with or without fee. Typical facilities include local parks, county parks, regional parks, special use facilities, linear parks/trails, resource conservancy parks, fairgrounds, zoos and cemeteries. Also, see Commercial Category – Amusement and Recreation Use Type for other types of recreation.

Level 3: Regional Parks. Regional Parks attract visitors from throughout the region and which may provide access to significant ecological, cultural, historical features or unique facilities.

18A.36.020 General Provisions for Accessory Uses and Structures.

- A. In all zones, there shall be no limit as to the number of accessory uses allowed on a lot provided:
1. The use is not prohibited from locating in the zone classification;
 2. The use meets all applicable development regulations; and
 3. The use is accessory to a lawfully established principal use.

Staff Comment: The site is zoned Parks and Recreation (PR), which allows Regional Parks and associated accessory uses and structures with the application of a Conditional Use.

Pierce County Development Regulations - Design Standards and Guidelines (Title 18J)

- Building design and architectural standards of this Title shall not apply, per 18J.10.040(C)1.b Building located at a local park, county park, regional park, linear park/trail or Resource Conservation Park.

Staff Comment: Under 18J, many developments require the adherence of design standards. However, in this instance there is an exemption provision from building design and architectural standards.

Pierce County Conservancy Shoreline Environment Designations (Pierce County Code, Title 18S.20.040)-key policies

- Active and passive outdoor recreation activities and resource-based uses such as timber harvesting, aquaculture, and passive agricultural uses such as pasture and range lands shall receive priority.
- Opportunities for ecological restoration should be pursued, giving priority to the areas with the greatest potential to restore ecosystem-wide processes (the site of naturally occurring physical and geologic processes of erosion, transport, and deposition; and specific chemical processes that shape landforms within a specific shoreline ecosystem and determine both the types of habitat and the associated 40 ecological functions) and functions.

- Development should be limited to that which sustains the shoreline area's physical and biological resources and temporary uses that do not substantially degrade ecological functions or the natural character.
- Agriculture, forestry, and aquaculture should be allowed.
- Water-dependent and water-enjoyment recreation facilities that do not deplete the resource over time including, but not limited to boating facilities, angling, hunting, wildlife viewing trails, and swimming beaches, may be allowed.
- Outstanding recreational or scenic values should be protected from incompatible development.

Staff Comment: The proposal is consistent with the Conservancy SED as it supports both active and passive outdoor recreation opportunities. The pathways add ADA access to the shoreline supporting viewing trails, hiking, and the ability for the public to better access the Puget Sound. Phase two of this project originally included the repair/installation of a pocket beach. The beach has been removed from the overall proposal to minimize the overall impact of the project. Public access opportunities that include active or passive outdoor activities are a preferred use in the Conservancy environment.

Pierce County Shoreline Management Use Regulations (Pierce County Code, Title 18S)

18S.30.030 Ecological Protection

- All development shall occur as defined in Table 18S.30.030-1, Mitigation Sequencing, with avoidance of impacts being the highest priority. Lower priority measures shall be applied only when higher priority measures are determined to be infeasible or inapplicable. Mitigation sequencing components consist of a series of consecutive steps beginning with avoidance and ending with monitoring and taking appropriate corrective measures.

Table 18S.30.030-1. Mitigation Sequencing	
Higher Priority ↓ Lower Priority	Avoiding the impact altogether by not taking a certain action or parts of actions.
	Minimizing impacts by limiting the degree or magnitude of the action and its implementation by using appropriate technology or by taking affirmative steps to avoid or reduce impacts.
	Rectify the impact by repairing, rehabilitating, or restoring the affected environment;
	Reducing or eliminating the impact over time by preservation and maintenance operations; or
	Compensate for the impact by replacing, enhancing, or providing substitute resources or environments.
	Monitoring the impact and compensation projects and taking appropriate corrective measures.

- Where new developments and uses are proposed, shoreline vegetation shall be conserved or restored when feasible. Shoreline vegetation helps to maintain shoreline ecological functions and processes and mitigate the direct, indirect and cumulative impacts of shoreline development
- Where retention of shoreline vegetation is not feasible, new developments shall include a vegetation management plan as defined in PCC 18S.30.030 G.2.

- The Department shall periodically evaluate the cumulative effects of all project review actions in shoreline areas.
- Standard shoreline buffers for the Conservancy shoreline environment is 100 feet.
- Water dependent uses and public shoreline access are allowed within the standard shoreline buffer subject to applicable regulations of the Master Program.
- Within the Natural and Conservancy SED impervious surfaces shall be limited to 10 percent effective impervious surfaces.
- The calculation for impervious surfaces shall include parking areas but may exclude a 12-foot-wide driveway. This restriction applies to both principal and accessory uses and structures.
- Retention of existing vegetation shall be a priority within the entire shoreline jurisdiction. Retention of existing trees is particularly important. Significant trees as identified in Table 18J.15.030-1 cannot be removed without approval of a vegetation planting plan. Prior to proposing any tree removal, the landowner shall first evaluate alternate means of achieving their development goals, such as selective limbing and tree topping.

Staff Comment: The project results in an increase in impervious surface by providing ADA compliant access to the public beach. This increase is not desirable, but it is related to providing public access which is a preferred use under the Shoreline Management Act. It should be noted that the new access is designed to be effectively pervious. Overall, the project demonstrates impact minimization through appropriate design and by repairing, rehabilitating, or restoring the affected environment. Staff feel that it has been sufficiently demonstrated that avoidance of impact was utilized to the degree feasible.

18S.30.040 Excavation, Dredging, Filling, and Grading

- Excavation, dredging, filling, and/or grading shall not occur without an authorized principal use or development.
- Excavation, dredging, filling, and/or grading shall be limited to the minimum amount necessary for the specific use or development proposed.
- Excavation, dredging, filling, and/or grading shall not unnecessarily impact natural processes such as water flow, circulation, currents, channel migration, erosion, sediment transport, and floodwater storage, and shall not cut off or isolate hydrologic features.
- Stabilization measures should be designed to blend physically and visually with existing topography.
- New development shall be located and designed to avoid or minimize the need for maintenance dredging.

Staff Comment: Some grading will be required during installation of the ADA walkways. Proposed plans show that the excavation, grading, and filling is being limited to the minimum amount necessary to create the ADA walkways.

18S.30.050 Shoreline Access

- Public Shoreline access shall consist of land or a physical improvement in the form of walkway, trail, bikeway, viewpoint, park, deck, observation tower, pier, boat launching ramp, dock or pier area, or other area serving as a means of view and/or physical approach to public waters.
- Public shoreline access may include interpretive centers and displays.

- Public shorelines access shall incorporate the following location and design criteria:
 - Public pedestrian access is required where open space, including critical areas, is provided along the water's edge, and public access can be provided in a manner that will not adversely impact shoreline ecological processes and functions.
 - The access shall be buffered from sensitive ecological features and provide limited and controlled access to the water's edge where appropriate.
 - Fencing may be used to control damage to plants and other sensitive ecological features.
 - Pedestrian access shall be constructed of permeable materials to reduce impacts to ecologically sensitive resources.
 - Public areas and shoreline access points shall connect to abutting public 23 sidewalks, walkways, trails and streets.
 - Where views of the water or shoreline are available and physical access to the water's edge is not present or appropriate, a public viewing area shall be provided.
 - Intrusions on privacy shall be minimized by avoiding locations adjacent to windows and outdoor private open spaces or by screening or other separation techniques.
 - Public Shoreline access design shall provide for the safety of users to the extent feasible. Appropriate amenities such as benches, picnic tables, and public parking sufficient to serve the users shall be provided.
- Public shoreline access sites (on or off site) should be fully developed and available for public use at the time of use or occupancy of the shoreline development. If a financial contribution to a parks department, agency, or entity furthering public access is allowed, the payment shall be received prior to occupancy, although the specific project it is funding need not be initiated.
- Public shoreline access provisions shall run with the land and be recorded via a legal instrument such as an easement, or as a dedication on the face of a plat or short plat. Such legal instruments shall be recorded with the County Auditor's Office prior to the time of building permit approval, occupancy, or plat approval, whichever comes first pursuant to RCW 58.17.110. Future actions by the applicant's successors in interest or other parties shall not diminish the usefulness or value of required public access areas and associated improvements.
- Shoreline access should be available to the public from dawn to dusk unless specific hours of operation are established through a shoreline permit or approval.
- Public shoreline access sites shall be made barrier-free for the physically disabled and in accordance with the Americans with Disabilities Act (ADA).
- Signs that indicate the public's right of shoreline access shall be constructed, installed, and maintained by the applicant or owner in conspicuous locations at public access sites.

Staff Comment: The proposal is clearly aimed at providing greater access to the public. The proposal also includes the possibility of signage and fencing to protect vegetation. Benches and picnic tables are going to be placed throughout the project and the parking will be located outside the 200-foot shoreline jurisdiction. The public will have access to the facilities during normal park hours.

This proposal has gone through several iterations in order to meet the requirement of 18S.30.050.D.1. Pedestrian access shall be constructed of permeable materials to reduce impacts to ecologically sensitive resources. The applicant has submitted designs that meet these requirements while also addressing concerns about slope stability.

18S.30.060 Scenic Protection and Compatibility

- Parking lots, including circulation driveways, shall be located as far inland as practicable with pedestrian access provided by walkways or other methods.
- Compatibility with, and impacts to, the following shall be considered: navigation, recreation, public access, public use of the beaches and surface waters, traffic, abutting uses, and views.
- Appropriate measures shall be employed to protect public safety and prevent adverse impacts on navigation, public access, recreation, and other approved shoreline development.

Staff Comment: Staff agrees that the proposal is compatible with recreation, public use of waters, traffic, abutting uses, and views. The parking that is being reoriented is outside of the 200-foot Shoreline Jurisdiction.

18S.30.090 Water Oriented Development

- Give priority to water-oriented uses over non water-oriented uses, with highest priority given to water-dependent uses.
- Parking areas associated with a principal use shall be located outside shorelines unless no feasible alternative location exists. Parking as a principal use is prohibited.
- Water dependent uses and public access to shorelines are preferred use in all shoreline environments.
- In the Conservancy SED, water-dependent and water-enjoyment recreation facilities that do not deplete the resource over time including, but not limited to boating facilities, angling, hunting, wildlife viewing trails, and swimming beaches, may be allowed if adverse impacts to the shoreline are mitigated.

Staff Comment: This proposal's use is supported by 18S.30.090, primarily consisting of public access trails and viewing areas. Included in this, is support for the overarching policy of the Pierce County Shoreline Master Program that, "The public's opportunity to enjoy the physical and aesthetic qualities of natural shorelines of the State shall be preserved to the greatest extent feasible, consistent with the overall best interest of the State and the people."

18S.30.100 Water Quality, Stormwater, and Nonpoint Pollution

Policies

- Locate, construct, and operate development in a manner that maintains or enhances the quantity and quality of surface and ground water over the long term.
- Prevent impacts to water quality and stormwater quantity that would result in a net loss of shoreline ecological functions.
- Prevent contamination of surface and ground water and soils.
- Minimize the need for chemical fertilizers, pesticides, or other similar chemical treatments.
- Encourage the use of low impact development (LID) techniques.
- Minimize the use of impervious surfaces.
- Protect commercial shellfish areas and legally established aquaculture enterprises from damaging sources of pollution.

Staff Comment: The stormwater treatment portion of the project runs along Park Exit Drive and through the upland parking lot. It then connects with Beach Road to the mechanical treatment structure. The mechanical treatment structures will then transport the treated stormwater down to an infiltration/dispersion trench. There exists opportunity for increased deployment of Low Impact Development (LID) techniques especially for the handling of stormwater runoff around the trail systems within the 200-foot jurisdiction. The proposal is collecting the water from the pathways and using a tight line to transport water down the slope to avoid additional water weakening the slope stability.

Use Development Policies and Regulations – Chapter 18S.40

18S.40.090 Recreation

Key Policies

- Give preference to developments that facilitate the public's ability to reach, touch, and enjoy the water's edge, to travel on the waters of the State, and to view the water and the shoreline.
- Provide ample, varied, and balanced recreational experiences in appropriate shoreline locations.
- Design facilities to accommodate expected capacity and to prevent overuse.
- Locate recreational developments so that use and intensity are consistent with the characteristics of the shoreline in which they are located.
- Discourage recreational development that requires extensive structures, utilities, roads, or substantial modifications of topography or vegetation removal.
- Incorporate public education regarding shoreline ecological functions and processes, the role of human actions on the environment, and the importance of public involvement in shoreline management.
- Encourage linkage of shoreline parks, upland recreation opportunities and water-oriented opportunities.
- Discourage vehicular traffic on beaches and the water's edge.

Regulation

- Locations and designs requiring flood protection or shoreline stabilization should be avoided.
- When multiple recreational facilities are proposed, cumulative impacts shall be addressed.
- Recreational water activities shall not impede the ability of watercraft to navigate past the site.
- Swimming areas, underwater parks, and similar uses shall include safety provisions to warn boating traffic of their location.
- Restrooms, refuse disposal, parking, maintenance, and similar facilities shall be provided consistent with the expected demand. Designs shall consider ways to prevent overuse of the site.

Staff Comment: This proposal is supported by preferences to facilitate the public's ability to reach, touch, and enjoy the water's edge, to travel on the waters of the state, and to view the water and the shoreline. The proposal within the shoreline jurisdiction contains public access that is ADA compliant and viewing areas.

The original proposal was going to establish a pocket beach at the water's edge. This has been abandoned and the current access to the water's edge will be repaired making it safer to access the water.

18S.40.110 Restoration and Enhancement

- Encourage restoration actions that enhance aquatic and upland ecological functions, processes, and physical features (such as native vegetation) and that address the needs of regulated fish and wildlife species.
- Encourage and support cooperative restoration efforts between local, state, and federal public agencies, tribes, non-profit organizations, and landowners to improve shorelines with impaired ecological functions and/or processes.
- Incorporate public education regarding shoreline ecological functions and processes, the role of human actions on the environment, and the importance of public involvement in shorelines management in restoration and enhancement plans.
- Restoration and enhancement projects shall achieve goals and objectives of the Pierce County Shoreline Restoration Plan or in other recovery plans for listed species and/or populations, provided such other plans are consistent with achieving goals and objectives in the Pierce County Shoreline Restoration Plan.

Staff Comment: The proposal already includes restoration in the form of trails to be vacated. The applicant is also in the process of creating a Vegetation Planting Plan. Throughout the entire proposal there also exists opportunity for educational signage areas near restoration efforts.

18S.40.120 Transportation

- Include systems for pedestrians, bicycle, and public transportation where appropriate in circulation system planning.
- Appropriate measures shall be employed to protect public safety and prevent adverse impacts on navigation, public access, recreation, and other approved shoreline uses.
- Parking areas associated with a principal use shall be located outside shorelines unless no feasible alternative location exists. Parking as a principal use is prohibited.

Staff Comment: The trail system is primarily for pedestrian foot traffic. The trails will be lined with natural material barriers, i.e. short rock walls or wooden pile fences. Parking facilities are both located outside of the 200-foot shoreline jurisdiction.

18S.40.130 Utilities

- Locate new public and private utilities inland from the land/water interface, preferably out of shorelines.
- Allow non water-oriented utility production and processing facilities, or parts of those facilities within shorelines, only when there is no other feasible option.
- Utilities should be underground, including underneath water bodies, unless such location would cause greater degradation to ecological functions or be technically prohibitive.
- Appropriate measures shall be employed to protect public safety and prevent adverse impacts on navigation, public access, recreation and other approved shoreline development.
- After construction, the work site shall be restored to the maximum extent possible.

- Any mitigation required shall be maintained for the life of the project.
- All normal utilities associated with a principal use shall be reviewed as part of the principal use.
- Applicants shall demonstrate the need for a shoreline location, and if the utility is proposed outside of an existing right-of-way, why collocation within existing right of-way is not feasible.

Staff Comment: The inlets for the stormwater facility are located along the upland roads and parking areas. This system is going to be located underground. Approval conditions require (in general) the site is to be restored to the maximum extent possible, future utilities be brought down the same pathway created for this stormwater pipe, and maintenance of the system shall be required for the life of the system.

18S.40.140 Water Access Facilities – key regulations

- Limited fill or excavation may be allowed landward of the OHWM to match the upland with the elevation of the over-water structure.
- Water access facilities are subject to Chapter 18E.110 PCC, Erosion Hazard Areas.
- Signage providing usage rules shall be provided and shall be located in a conspicuous manner.

Staff Comment: This section is not generally applicable as the pocket beach has been removed from this proposal. There are repairs being done to the existing stairs and pathways to the beach.

Pierce County Code Title 18A Development Regulations – Zoning

For the Required Findings below the applicant’s comments are provided verbatim followed by Staff Comment.

18A.75.030.B.1 Required Findings Conditional Use

a. The granting of the proposed Conditional Use Permit will not:

1) be detrimental to the public health, safety, and general welfare;

Applicant’s Comment: The granting of the proposed Conditional Use Permit will not result in detrimental effects to the public health, safety and general welfare. This project incorporates many design features intended to improve hazardous site conditions such as traffic/pedestrian safety, steep slopes and shoreline access, and landslide and erosion hazards as discussed in more detail below (see Question D). Public benefits of the project include safer pedestrian access, improved Americans with Disabilities Act (ADA) access and increased recreation opportunities.

2) adversely affect the established character and planned character of the surrounding vicinity; nor

Applicant’s Comment: This project implements the Kopachuck State Park Master Plan developed in 2014 to provide park improvements for the public. Development of the master plan was accomplished through an extensive public involvement process that included formation of an ad hoc committee that met regularly, meetings with staff, and

presentations to the public. Two open public meetings were held to solicit feedback from the citizens in the community. A list of design criteria was used to guide and evaluate the master plan as it was developed. These criteria were developed using input from the ad hoc committee, feedback from the initial public meeting and comments from staff. The new event building and welcome center were designed based on feedback from the ad hoc committee and public who advocated for an attractive new picnic shelter that could be enclosed and utilized year-round. The proposed buildings were sited and designed to enhance viewing opportunities of Colvos Passage and the surrounding forest. Scaled to be visually attractive and integrate seamlessly into the site as a whole, these new facilities will establish the rustic and forested character and quality for the rest of the proposed improvements. This project will preserve and maintain the natural vegetated buffers and forested characteristics of the site and promote views of Puget Sound consistent with the Urban and Rural Design goals in the Community Character and Design Element (Chapter 3) of the Gig Harbor Community Plan.

3) be injurious to the uses, planned uses, property, or improvements adjacent to, and in the vicinity of, the site upon which the proposed use is to be located.

Applicant's Comment: This project proposes site improvements to an existing State Park that will enhance the day use facilities and capabilities of the site. All proposed improvements will occur within the existing developed areas of the park away from adjoining properties and uses (primarily residential) which are some distance away. The project is not anticipated to result in any land use impacts. The project has been designed to be compatible with existing and projected land uses and plans and meet all applicable development regulations. Two Customer Information Meetings with Pierce County staff have helped guide the development of this project, one on April 9, 2014 and on December 6, 2018. State Parks will continue to work with Pierce County to ensure that we meet all applicable regulations and receive all required approvals.

b. That the granting of the proposed Conditional Use Permit is consistent and compatible with the intent of the goals, objectives and policies of the County's Comprehensive Plan, appropriate Community Plan (provided that, in the event of conflict with the Comprehensive Plan, the Comprehensive Plan prevails), and any implementing regulation.

Applicant's Comment: The project is consistent and compatible with the intent of the goals, objectives and policies of the Gig Harbor Community Plan and Title 18S PCC. Specifically, this project supports the Community Plan as discussed below.

Community Wide Goals. Despite its beautiful location, Kopachuck is severely underutilized due to several factors: closure of the individual and group camp sites due to laminated root rot, lack of public knowledge about the park, and limited and low-quality facilities. Updating and improving the day use facilities will enable the park to better serve the public and meet the Community Wide Recreation Goal "to assure that abundant and varied recreation opportunities are established and enhanced to serve as focal points for present and future population needs as an integral part of neighborhoods and the larger community."

Environment Policies. The goal of the Kopachuck State Park Master Plan process was to develop a plan that would protect park resources, enhance park visitation, comply with applicable state park and land use policies and create a park that is sustainable in terms of operation costs and revenues. The result was a project that, as designed, meets the Environment Policies goals to:

- provide residents the opportunity to live, work, and play in a healthy environment;
- maintain, protect and enhance the natural features which contribute to the scenic beauty and livability of the area for the enjoyment and use of present and future generations; and
- protect and conserve all elements of the natural environment.

This project has sited the new buildings and improvements to avoid and minimize environmental impacts. Two geotechnical evaluations, a wetland assessment, and a habitat assessment of the project area have been conducted to inform the overall site design and stormwater drainage plan consistent with goals GH ENV-7.1, GH ENV-7.2, GH ENV-9, and GH ENV-10.4.1 of the policy. Based on consultation with the State Parks Forester, the proposed welcome center, event building and amphitheater were relocated to avoid impacts to significant trees and minimize impacts to critical root zones to the extent possible. In all areas of the project, the intent is to salvage or replant native vegetation to infill adjacent to improvements, which will help provide areas for infiltration of surface water and groundwater recharge to occur consistent with goal GH ENV-8.1. Additional plantings will occur to restore remaining disturbed areas. All planted and transplanted areas in the upper day use area will be irrigated with drip line to promote water conservation consistent with goal GH ENV-8.3.

Parks and Recreation Policies

Kopachuck State Park is considered a Regional Park and the proposed improvements will help meet the Parks and Recreation Policies goals to: provide adequate park and recreational facilities within the community plan area that satisfy the highest standards for environmental protection while meeting the needs of Peninsula residents; and provide and maintain a level of service for regional parks in the community that meets or exceeds the countywide standard. In addition, the proposed ADA improvements will provide much needed access to restrooms, park features and shorelands consistent with goal GH PR-8.2 of the policy.

Transportation Policies

This project incorporates pedestrian access improvements for local residents and students from the adjacent Voyager Elementary School and Kopachuck Middle School who use the park for educational programs. The project will construct a new pedestrian walkway along 56th St NW from 106th Ave NW/Artondale Ct NW to the day use area in order to separate pedestrian access from vehicular access for safety purposes consistent with goals GH T-2 and GH T-8 of this policy.

- c. **That all conditions necessary to lessen any impacts of the proposed use are conditions that can be monitored and enforced.**

Applicant's Comment: There are no anticipated significant adverse effects to the environment as a result of this project. State Parks completed a SEPA environmental checklist and issued a Determination of Non-significance in 2014 and prepared an addendum in 2019. This project proposes improvements to the existing recreational use of the park and will improve public access, maintain the ecological conditions of the park and preserve the visual aesthetics of the area. A Tree Preservation and Planting Plan has been prepared and will be provided to the contractor hired to construct the project. Builders will be required to implement a Stormwater Pollution Prevention Plan, which includes the use of temporary erosion controls, best management practices and construction practices for controlling erosion. A cultural resources survey of the project has been completed and an inadvertent discovery plan to address any unanticipated discoveries made during construction will be developed and incorporated in the final construction plans. Adherence to these plans will be monitored and enforced by State Parks Capital staff in charge of the project. The project has been designed to meet all applicable development regulations. State Parks will continue to work with Pierce County to ensure that we meet all applicable regulations and receive all required approvals. Adherence to all permit conditions and required inspections will ensure proper enforcement.

- d. **That the proposed use will not introduce hazardous conditions at the site that cannot be mitigated to protect adjacent properties, the vicinity, and the public health, safety, and welfare of the community from such hazard.**

Applicant's Comment: This project incorporates many design features intended to improve hazardous site conditions such as landslide and erosion hazards, laminated root rot, access issues, and traffic/pedestrian safety, which will help protect the public health, safety and welfare of the community. Two pressing concerns at the site are slope instability - damaging and threatening to trails, restrooms and beach access – and ground movement which has resulted in cracks and slumps in several areas including the beach area restroom and marine campsite. The beach restroom was removed in 2014 and the campsite was relocated in 2016 due to geologic instability and safety concerns. In order to ensure public safety, the new beach restroom will be relocated to the existing parking lot area, which has remained stable. The project adheres to the design recommendations provided in the Subsurface Exploration, Geological Hazard, and Geotechnical Engineering Report prepared for the project (2018). The new event building and welcome center have been located to meet the recommended building setback from the top of the headscarp to provide a suitable buffer to protect future structures and associated improvements. Additionally, stormwater treatment will tight line runoff down to the beach area to avoid saturating unstable slopes. Due to dangers posed by laminated root rot, the campground has been eliminated and the development of overnight and sitting areas within the fall zone of affected trees has been prohibited. The area of the existing parking lot within the delineated fall zone will become a rain garden/treatment swale to capture stormwater runoff. Other unsatisfactory conditions at present include uneven and inconsistent trail treads, no ADA-compliant trails, and no ADA-accessible routes to restrooms or park features. This project will provide improved ADA walkways and boardwalks to accommodate universal access to the new event building, welcome center, amphitheater, picnic areas and beach. In order to improve safety and vehicle access into the park,

access/egress for the park is being reversed giving those exiting the park more adequate site distance. In addition, a new pedestrian walkway will be constructed along 56th St NW from 106th Ave NW/Artondale Ct NW to the day use area to separate pedestrian access from vehicle access.

- e. **That the conditional use will be supported by, and not adversely affect, adequate public facilities and services, or that conditions can be imposed to lessen any adverse impacts on such facilities and services.**

Applicant's Comments: This project is intended to enhance the existing public park facilities and will benefit public services. Proposed improvements will upgrade the existing sewer lines, stormwater system, and water services from a Blue operating permit to a Green operating permit. The addition of security cameras and the ability for park rangers to operate gates remotely will enhance site security. The addition of security cameras and a staffed welcome center at the entrance of the parking lot will reduce the potential for vandalism or theft reducing the need for police calls. In addition, the beach access road improvements will enhance the turnaround for emergency vehicles at the beach area.

- f. **That the Level of Service standards for public facilities and services are met in accordance with concurrency management requirements**

Applicant's Comment: One of the goals of the Gig Harbor Community Plan is to provide and maintain a level of service for regional parks in the community that meets or exceeds the countywide standard. Kopachuck is an existing 280-acre State Park that is considered by Pierce County to be a Regional Park. Based on the Community Plan estimated 2017 plan area population of 52,000, the park greatly exceeds the County's proposed LOS standard of 1.50 or 78 acres.

Staff Comment: The Conditional Use Permit is for the expansion of park facilities including a new day use area and associated building, a welcome center, new water main, new sanitary force main, and reconfiguring of the parking lot. This expansion is within the already developed areas and would allow for greater access to the park and associated facilities. Staff agrees that there will be no significant adverse effects to the environment as a result of approval of the Conditional Use Permit. Some LID techniques are being utilized in regard to vegetation and stormwater and since this project is centrally located the existing trees would operate as a visual break and noise reduction screen during construction to neighboring properties. This project's intent also aligns with the Comprehensive Plan, Gig Harbor Community Plan, and Pierce County Code.

Shoreline Variance (18S.60.070)

Decision Criteria – Development Landward of Ordinary High Water Mark (OHWM)

1. **The strict application of the bulk or dimensional standards precludes or significantly interferes with reasonable use of the property.**

Applicant's Comment: Without the requested variance for the stormwater treatment system, State Parks would not be able to construct the necessary park improvements needed to fulfill the 2014 Kopachuck State Park Master Plan. Strict application of the standard 100-ft buffer would significantly interfere with stormwater treatment and outfall at the park. The park's geology and

topography pose challenges to siting, construction, and maintaining safe and stable facilities. A site reconnaissance level survey of the geological hazards and conditions at Kopachuck was conducted by Associated Earth Sciences, Inc. (AESI) in 2012 and 2018. According to the two AESI reports, the park is roughly divided into two major areas, the upland portion and the lower portion, clearly defined by an abrupt edge or head scarp. The upland area is relatively stable, but the lower area is a mapped landslide complex showing indications of localized soil creep. Both AESI reports recommend that all storm water from impervious surfaces should not be discharged directly onto the steep slopes but, instead directed away from the slopes or tight lined to the bottom of the slope. Concentration of runoff water could form new channels or flow into existing channels causing erosion and sediment transport, and potentially decreasing the stability of site slopes. In addition, an increase in ground water recharge could impact the deep-seated stability of the landslide complex. These conditions necessitate that the stormwater outfall be located at the bottom of the slope, which is located at the beach, to reduce storm water impacts and protect the existing development within the park. Based on consultation with Washington Department of Fish and Wildlife (WDFW) Habitat Biologist Matthew Curtis (site visit conducted September 13, 2018), any proposed outfall in this area is required to have some sort of energy dissipator at the end and fish must not be able to access the outfall. By burying the level spreader under the proposed pocket beach, this design meets both WDFW requirements.

- 2. The hardship described in 1 above is specifically related to the property and is the result of unique conditions such as irregular lot shape, size, or natural features and the application of Title 18S PCC and not, for example, from deed restrictions or the applicant's own actions.**

Applicant's Comment: As discussed above, the hardship is specifically related to sites constraints associated with the geology and topography of the State Park property and not from deed restrictions or other actions.

- 3. The design of the project is compatible with other authorized development within the area and with development planned for the area under the comprehensive plan and Title 18S PCC and will not cause adverse impacts to the shoreline environment.**

Applicant's Comment: The project is compatible with other authorized development planned for the area under the comprehensive plan (Gig Harbor Community Plan) and Title 18S PCC. Specifically, this project supports Community Plan goals to "assure abundant and varied recreation opportunities" (Recreation) and "promote development of public and private pedestrian access to shoreland and tidelands" (GH PR-8.2). The project is located within the Conservancy shoreline environment designation and helps promotes the goals of Title 18S PPC such as providing improved public access. The project will improve public access, maintain the ecological conditions of the shoreline and preserve the visual aesthetics of the area.

- 4. The Shoreline Variance will not constitute a grant of special privilege not enjoyed by the other properties in the area.**

Applicant's Comment: Granting of this variance should not be considered a grant of special privilege. This project will not prevent or impact the ability of others the area to seek approval for similar projects.

5. The Shoreline Variance requested is the minimum necessary to afford relief.

Applicant's Comment: The stormwater outfall has been sited to avoid and minimize environmental impacts. The pipes and treatment vault are proposed to be located outside of the shoreline buffer under the existing access road and parking area. The only portion that will be located within the buffer requiring a variance is the new level spreader and infiltration trench. This location will minimize impacts because it will be constructed under the area that will become the new pocket beach. Because the stormwater treatment system and outfall will be buried underground, it will not interfere with normal public use of the shoreline at the park or the visual aesthetics of the area.

Staff Comment: Staff agrees that topography and geological issues do reasonably affect the use of the property. If the stormwater is not handled and transported after treatment to a lower elevation the flow would likely impact slope stability. To further minimize impacts, storm facilities will be placed in the disturbance footprint of other improvements and the pocket beach was removed from the overall proposal. The stormwater facility will support the development both within the shoreline jurisdiction and the upland development to allow for greater public access, recreation opportunities, and also educational opportunities for the public. Staff also agrees that granting of this Shoreline Variance would be the minimum necessary to afford relief from the 100-foot buffer as placing the outfall higher on the property outside of the buffer would create more ecological harm as the water outlet would likely cause the slope to fail and damage the parks trees, damage improvements, and create conditions that would be unsafe to the public.

Conditions of Approval

Should the project be approved by the Examiner, the applicants must comply with all applicable provisions of Federal, State, local regulations and the conditions of this staff report.

Planning:

1. The decision set forth herein is based upon representations made and exhibits, including plans and proposals submitted at the hearing conducted by the Examiner. Pursuant to WAC 173-27-100, any substantial change to the design, terms, or conditions of the project shall be subject to approval of the Examiner and may require further and additional hearings.
2. Development shall be started/completed per the timelines in WAC section 173-27-090 for the development within shoreline jurisdiction.
3. The applicant shall adhere to all conditions imposed under the authority of the Pierce County Hearing Examiner.
4. Additional conditions may be imposed through the County Building Permit review process.
5. The Shoreline Variance requires approval by the Washington State Department of Ecology.
6. The Pocket Beach described in application materials, JARPA, has been removed from the proposal to minimize impacts.

d

7. The Site Plan – Beach Area, Site Plan – Day Use Area, and Site Plan – all revised June 1, 2020, located under Geological Assessment (Non-Residential) – 922461, are the site plans proposed by this application. If approved, any change to the above referenced site plans will be subject to Revision to Shoreline Permit 18S.60.080.
8. Prior to issuance of the building permit, the applicants/property owners must submit and receive approval of a vegetation planting plan. The applicants must install the plantings within the next planting season and must submit the plan to the Planning Department for approval. The vegetative planting plan shall include monitoring and maintenance per 18S.30.030. If any vegetation is removed and/or dies at any time it must be replaced within 180 days. **No permit will be issued until a vegetation planting plan is submitted and has been approved by the Planning Department.** Disputes regarding the plan may be returned to the Examiner for resolution in writing.
9. Should archeological materials or human remains be observed, work shall stop and the State Department of Archeology and Historic Preservation, County Planning Department, affected Tribes and County Coroner (if applicable), shall be contacted immediately. See the “inadvertent Archeological and Historic Resources Discovery Plan” at the end of the Staff Report.

Resource Management:

10. The proposed day use improvements will avoid impacts to all identified wetlands and associated buffers.
11. Once this project is approved by the Pierce County Hearing Examiner, issuance of the Final Wetland and Habitat Conservation Area Approval documents will be required to be recorded with the Pierce County Auditor’s Office prior to the issuance of any permits on-site.

Development Engineering:

12. The applicant is responsible for following all recommendations contained in the approved landslide geotechnical assessment. Upon discovery of poor/unstable soils, the contractor shall stop work and consult the geotechnical engineer for recommendations and shall notify pierce county development engineering.

List of Exhibits Provided to the Pierce County Hearing Examiner

1. STAFF REPORT
2. APPLICATION:
 - A. Joint Aquatic Resources Permit Application (JARPA), dated March 15, 2019
 - B. Required Findings – Conditional Use
 - C. Cover letter from Jessica Norton, Environmental Planner with Washington State Parks and Recreation Commission (WSPRC), dated March 18, 2019
 - D. Site Photos
 - E. Applications: #906881 (SD); #906883 (SDV); #908629; #906884 (SEPA)
3. STATE ENVIRONMENTAL POLICY ACT (SEPA):
 - A. Determination of Nonsignificance (DNS), from WSPRC, dated June 27, 2014
 - B. Addendum to DNS, from WSPRC, issued March 15, 2019
4. AGENCY COMMENTS:
 - A. Requests for Review and Response, emailed April 3, 2019, and April 19, 2019
 - B. Email from Deborah Johnson, Washington State Department of Health, dated April 19, 2019
 - C. Email from Rhonda Foster, Squaxin Island Tribe, dated April 23, 2019
 - D. Memorandum from Dan Smith, Development Engineer, dated April 29, 2019
 - E. Letter in response to Dan Smith Memo., from Brian Yearout, WSPRC, dated May 6, 2019
 - F. Letter from Scott Sissons, Environmental Biologist, to Jessica Norton, dated May 15, 2019
 - G. Letter in response to review comments from Lori Roosendaal, Fire Prevention, dated May 17, 2019
 - H. Letter in support of the project from Patricia T. Lantz, WSPRC, dated May 20, 2019
 - I. Email from Rob Jenkins regarding time extension due to COVID-19, dated June 5, 2020
 - J. PALS+ comments
5. PUBLIC COMMENTS/PARTIES OF RECORD:
 - A. Party of Record Requests
 - B. PAC Sign-in Sheet
 - C. Letter from Dr. Shema Henebutte and Dr. Ulf Hanebutte, dated April 29, 2019
 - D. Letter from Michael B. Murphy, dated May 22, 2019
6. NOTICE AND ROUTING DOCUMENTS:
 - A. Notice of Application (NOA), mailing lists, and map, dated April 3, 2019
 - B. Revised NOA, mailing lists, and map, dated April 19, 2019
 - C. Declarations of Postings of Posting, dated April 13, 2019
 - D. Public Notice, Agenda, mailing lists, map, legal notice, and letter
7. LAND USE ADVISORY COMMISSION (LUAC):
 - A. Agenda and Legal Notice for the PAC meeting on May 22, 2019
 - B. Sign-in Sheet and Minutes for the PAC meeting on May 22, 2019
8. REPORTS AND STUDIES:
 - A. Geologic Hazard Evaluation from Associated Earth Sciences, Inc., dated November 16, 2012
 - B. Habitat Assessment prepared by PND Engineers, Inc., dated February 28, 2019
 - C. Geotechnical Engineering Report, Upland Day-Use Improvements, dated May 9, 2019
 - D. Geotechnical Engineering Report, Park Beach Area Improvements, dated September 30, 2019
9. SITE PLANS:
 - A. Original Site Plan, Grading Plans, and Landscape Plans, dated November 7, 2018
 - B. Revised Proposed Site Plan, dated May 7, 2020
 - C. Revised Beach Area Plan, dated May 7, 2020
 - D. Revised Day Use Area Plan, dated May 7, 2020
 - E. Revised Landscape Planting Plan, dated February 28, 2019
 - F. ADA Beach Access Walk & Rock Wall Section Plan

Please note: A complete set of exhibits may be found at the following link:

<https://pals.piercecountywa.gov/palsonline/#/permitSearch/permit/documents?applPermitId=906881>

Appendix

Inadvertent Archaeological and Historic Resources Discovery Plan

In the event that any ground-disturbing activities or other project activities related to this development, or in any future development, uncover protected cultural material (e.g., bones, shell, antler, horn or stone tools), the following actions will be taken:

1. When an unanticipated discovery of protected cultural material (see definitions below) occurs, the property owner or contractor will completely secure the location and contact:
 - a. The property owner and/or project manager;
 - b. A professional archaeologist;
 - c. Pierce County Planning and Public Works Department (253-798-7037);
 - d. The Department of Archaeology and Historic Preservation (DAHP) (Stephanie Jolivette, State Archeologist, 360-586-3088, 360-628-2755 cell);
 - e. The Puyallup Tribe (Brandon Reynon, Cultural Regulatory Specialist, 253-573-7986, 360-384-2298);
 - f. The Squaxin Island Tribe (Shaun Dinubilo, 360-432-3850);
 - g. The Nisqually Tribe (Jackie Wall, Cultural Resources, 360-456-5221, ext. 2180) and
 - h. The Muckleshoot Tribe (Laura Murphy, Archaeologist, 253-876-3272).
2. If the discovery is human remains, the property owner or contractor will stop work in and adjacent to the discovery, completely secure the work area by moving the land-altering equipment to a reasonable distance, and will immediately contact:
 - a. The property owner;
 - b. The Pierce County Sheriff's Department (253-798-4721); and
 - c. The Pierce County Medical Examiner, Thomas B. Clark, MD (253-798-6494) to determine if the remains are forensic in nature.
 - d. If the remains are not forensic in nature the Department of Archaeology and Historic Preservation (DAHP) Guy Tasa, State Physical Anthropologist, 360-586-3534; will take the lead on determining the appropriate method of treatment for the remains and will consult with the affected tribes.
3. Cultural material that may be protected by law could include but is not limited to:
 - a. Buried layers of black soil with layers of shell, charcoal, and fish and mammal bones (Figure 1);
 - b. Non-natural sediment or stone deposits that may be related to activity areas of people;
 - c. Stone, bone, shell, horn, or antler tools that may include projectile points (arrowheads), scrapers, cutting tools, wood working wedges or axes, and grinding stones (Figures 2 and 3);
 - d. Stone tools or stone flakes (Figures 2 and 3);
 - e. Buried cobbles that may indicate a hearth feature (Figure 4);
 - f. Old ceramic pieces, metal pieces, tools and bottles (Figures 5 and 6); and
 - g. Perennially damp areas may have preservation conditions that allow for remnants of wood and other plant fibers; in these locations there may be remains including: Fragments of basketry, weaving, wood tools, or carved pieces; and Human remains.
4. Compliance with all applicable laws pertaining to Archaeological Resources (RCW 27.53, 27.44 and WAC 25-48) and with human remains (RCW 68.50) is required. Failure to comply with these requirements could result in a misdemeanor and possible civil penalties and constitute a felony.

Figure 1: Shell midden



Figure 2: Example of stone tools



Figure 3: Example of stone flake



Figure 4: Example of hearth (oven) feature



Figure 5: Example of historic artifacts from debris scatter



Figure 6: Example of bottle from historic debris dump



Attachment 5

Critical Areas Review Permit



Sent via Email and Regular Mail on October 5th, 2020

October 2, 2020

Washington State Parks – Jessica Norton
PO Box 42650
Olympia, WA 98501
jessica.norton@parks.wa.gov

Subject: Critical Area Title Notification for Kopachuck State Park Day Use Development, Parcel No. 0121161010, Habitat Assessment App. No. 906886 & Wetland App. No. 906888, Shoreline Substantial Development App. No. 906881, Shoreline Conditional Use App. No. 908629, Shoreline Variance App. No. 906883, SEPA App. No. 906884

Dear Ms. Norton:

On September 24, 2020 the Pierce County Hearing Examiner approved this proposal subject to several Conditions. Condition #11 requires wetland and fish & wildlife approval. The project meets the requirements of Title 18E.40. (Fish & Wildlife) & Title 18E.30 (Wetlands) Development Regulations - Critical Areas.

This parcel contains wetlands and Habitat of Local Importance (forage fish & regulated water types), therefore a Critical Area Title Notification (enclosed) is required as part of Pierce County’s wetland and fish and wildlife review.

Please sign and notarize the Title Notice and record with the Pierce County Auditor's Office. Once recorded; please provide me with the Auditor’s Fee Recording Number (AFN).

Due to the COVID-19 outbreak, effective immediately Pierce County Recording is offering limited, in-person, services. Please call the Auditor’s Office first to make an appointment at 253-798-7440. I have also attached a list of companies that do electronic recordings for a small fee.

This will then complete the wetland and fish & wildlife approval required by Pierce County Resource Management.

Please be advised that other County departments may have additional requirements associated with your project. It is the applicant’s responsibility to research and comply with all other local, state and federal regulations and obtain relevant permits.

If you have any questions, please feel free to call me at (253) 798-2758 or via email at scott.sissons@piercescountywa.gov.

Sincerely,

Scott R. Sissons
Environmental Biologist 3

SRS:ds
543686 KopachuckPark_CriticalAreaTitleNotification.docx

Enclosures: Critical Area Title Notification
List of Companies that do Electronic Recordings

cc: Robert Perez, Associate Planner

Return to:
Washington State Parks
PO Box 42650
Olympia, WA 98501

TITLE NOTIFICATION – CRITICAL AREA

For purposes of this agreement and for indexing by the Auditor as required by R.C.W. Chapter 65.04, the parties to this agreement are Washington State Parks, Grantor, and Pierce County, Grantee.

Present Owner: Washington State Parks

Parcel Number: 0121161010

Parcel Address: 11101 – 56th Street NW

Legal description: (abbreviated: i.e., lot, block, subdivision name/number or quarter/quarter section, township, range): Section 16 Township 21 Range 01 Quarter 13: THAT POR OF SE OF NW LY NWLY OF ROSEDALE BAY RELOCATION RD ALSO SW OF NE ALSO LOT 2 ALSO NW OF SE EXC RDS

Notice: A portion, or all of this, site lies within a:

Wetlands and Fish & Wildlife Habitat Area (Forage Fish & Regulated Water Types), as defined by Pierce County Code Title 18E.30 & 18E.40.

Proposed Action: This project will renovate and expand the day-use area of Kopachuck State Park. Elements include new kitchen and picnic shelters, ADA-compliant trails and picnic areas, improved access to the water, playground equipment, interpretive signs, replacing an antiquated restroom, and parking lot improvements, which include new pavement, stormwater improvements, striping, bumper blocks and bike racks. This will be a phased project, portions of which take place outside the shoreline jurisdiction. Phase one consists of the stormwater system, reconstructing upper parking lot and entry and exit roads, new day use buildings, a welcome center, ADA accessible picnic area, amphitheater and play areas. Phase two originally included a pocket beach to be installed but this was removed from the overall proposal to minimize impacts. ADA pathways are still part of the overall proposal.

Chler Ham
Signature of Owner(s)

Chelsea Hamer
Print Name(s)

NOTARY:

STATE OF WASHINGTON)

) ss
COUNTY OF PIERCE Thurston

On this 31st day of December, 2020, before me, the undersigned, a Notary Public in and for the State of Washington, duly commissioned and sworn, personally appeared Chelsea Hamer to me known to be the individual described in and who executed the foregoing instrument, and acknowledged to me that he/she/they signed and sealed the said instrument as a free and voluntary act and deed for the uses and purposes therein mentioned.

Given under my hand and official seal this 31st day of December, 2020
Sneytouch Ryser
Notary Public in and for the State of Washington

Residing at Tumwater

My commission expires 10-3-23



AFFIX SEAL OR STAMP ABOVE THIS LINE

Attachment 6

Forest Practices ICN & Communication

From: [Adonais Clark](#)
To: [Hamer, Chelsea \(PARKS\)](#)
Cc: [Robert Perez](#); [Adonais Clark](#)
Subject: RE: Kopachuck State Park Day Use - Pierce County Permit Applications #906881 and #908629
Date: Wednesday, July 06, 2022 10:52:44 AM
Attachments: [image001.png](#)

External Email

Hi Chelsea,

Sorry for the delay in responding.

We have reviewed the Washington State Department of Natural Resources (DNR) Informal Conference Note (ICN) for Kopachuck State Park, dated September 29, 2021.

We note that the ICN states, "All of the trees that were proposed for removal were located within a tree length and half of a permanent structure that is frequented by people and not considered forest land. No forest practice permit is required from WDNR for tree removal on this site."

The removal of merchantable timber on non-forestland does not require a forest practices permit.

It is our determination that no forest practices permit is required from Pierce County for the proposed removal of merchantable timber at Kopachuck State Park, that is located within a tree length and half of a permanent structure that is frequented by people, as discussed with the DNR and documented in the ICN, dated September 29, 2021.

Take care.

Adonais



Adonais Clark
Senior Planner

Planning & Public Works | Land Use and Environmental Review
(253) 798-7165

From: Hamer, Chelsea (PARKS) <Chelsea.Hamer@PARKS.WA.GOV>
Sent: Wednesday, May 25, 2022 11:56 AM
To: Adonais Clark <adonais.clark@piercecountywa.gov>
Subject: Kopachuck State Park Day Use

Hello Adonais,

I hope your time off was wonderful!

This is just a follow-up to our conversation last month regarding Kopachuck State Park and forest practices permitting – I have attached the ICN from the site visit with DNR.

To recap our discussion, a forest practices permit is not required from WADNR nor the county since the tree removal would be occurring within one and a half tree lengths of existing structures frequently used by the public and is therefore not considered forest land; the tree removal was also reviewed during the county shoreline and critical areas permitting process. Could the county please provide State Parks with a letter for our project files confirming that a forest practices permit is not required?

Please let me know if you have any questions or if you would like to discuss any of this further.

Thank you!

Chelsea Hamer

Environmental Planner | SW Region Capital Program

Washington State Parks & Recreation Commission

PO BOX 42650 | 1111 Israel Rd SW | Olympia, WA 98504-2650

Cell: (360)790-8512 | chelsea.hamer@parks.wa.gov



Legal Subdivision	Section	TWP	RGE E/W	Application / Notification #	Class
	16	21	1 E		
Landowner	Timber Owner	Operator			
Kopachuck State Park					
Mailing Address	Mailing Address	Mailing Address			
10712 56 th St NW					
City, State / Province, Zip / Postal Code	City, State / Province, Zip / Postal Code	City, State / Province, Zip / Postal Code			
Gig Harbor Wa 98335					
Meeting Location	Telephone Conference []	Date	Time	Region	
on-site		9-29-2007	10:00	SPS	

Subjects Discussed:

KSP requested site visit to determine if they need a permit from WPNR for harvest of trees around existing structures

- tree length & 1/2 = 250' from existing structure Not Forest land

- Trees that are located within a tree length & half of a permanent structure that is frequented by people are not considered forest land.

Decisions Made:

* All of the trees that were proposed for removal were located within a tree length and half of a permanent structure that is frequented by people and not considered forest land.

No forest practice permit is required from WPNR for tree removal on this site. You should contact (Pierce County/local government) to see if they require permits for tree harvest.
RCW 76.09.020

PRINT Participants' Names	*SIGNATURES of Participants	Representing	Copies Mailed
Chelsea Himer		Kopachuck State Park	[]
			[]
			[]

Position No.	Signature & Title of DNR Representative	Date	Work Phone
3054		9-29-21	360 895 1631

* Participant signature means Note is correct for subjects discussed and decisions made at the meeting.

Did not attend -- mail copies to:

[] Timber Owner [] Landowner [] Other Parties: P.C. - Adonis Clark

**KOPACHUCK STATE PARK
DAY USE DEVELOPMENT**

The following list of major items of construction has been included for Bidder's convenience in preparing a bid proposal. Exclusion of items from this summary does not indicate exclusion from project. For lump sum items, the bidder is cautioned that the drawings are the only source for measurement of project quantities, and drawings have been detailed for this purpose. In preparing a bid proposal, Bidder should note apparent discrepancies between the list below and the drawings and consult with Engineer for verification.

Base Bid includes all work shown and specified, except Bid Alternates.

BASE BID ITEMS

BID ITEM	DESCRIPTION	ESTIMATED QUANTITY	PAYMENT
1.	TRENCH EXCAVATION SAFETY PROVISIONS See instructions on Bid Proposal Form.	L.S.	PER LUMP SUM
2.	MOBILIZATION This item shall consist of preparatory Work and operations including, but not limited to those necessary for the movement of equipment, supplies and incidentals to the Project site; and bonding, insurance, etc. A. Payment shall be based on a percentage of actual construction completed at time of payment estimate.	L.S.	PER LUMP SUM
3.	DAY USE AREA SITE IMPROVEMENTS This item shall consist of all day use area site improvements including demolition, clearing, grubbing, grading, concrete, asphalt, sanitary sewer, storm sewer, domestic water, electrical systems, and landscape planting other than specific elements identified in other bid items listed below. A. Payment shall be based on a percentage of actual construction completed at time of payment estimate.	L.S.	PER LUMP SUM
4.	PARK ENTRY STRUCTURE This item shall consist of all work related to construction of the Park Entry Structure and Sign, including structure footings and vehicular access gate and footings. A. Payment shall be based on a percentage of actual construction completed at time of payment estimate.	L.S.	PER LUMP SUM

**KOPACHUCK STATE PARK
DAY USE DEVELOPMENT**

10. WELCOME CENTER BUILDING L.S. PER LUMP SUM

This item shall consist of all work related to construction of the Welcome Center Building, including all mechanical and electrical systems within the building.

A. Payment shall be based on a percentage of actual construction completed at time of payment estimate.

11. STORM DRAINAGE TO BEACH AREA L.S. PER LUMP SUM

This item shall consist of all work related to construction of the storm drainage connection from the beach access gate to the beach area dispersion trench, including all clearing, trenching, storm drainage, catch basins, stormwater filter vault, sediment control structure, dispersion trench, landscape restoration, and beach access wood stair.

A. Payment shall be based on a percentage of actual construction completed at time of payment estimate.

12. SITE SECURITY CCTV SYSTEM L.S. PER LUMP SUM

This item shall consist of all work related to the bidder-designed site security CCTV Video Surveillance system including cameras, conduits, handholes, cabling, recording equipment, etc. located on-site and within the Day Use Building and Welcome Center that comprise a complete turn-key system.

A. Payment shall be based on a percentage of actual construction completed at time of payment estimate.

ALTERNATE BID ITEMS

ALTERNATE

BID ITEM	DESCRIPTION	ESTIMATED QUANTITY	PAYMENT
---------------------	--------------------	-------------------------------	----------------

A1. WOOD DECK/RAMP & STAIRS DAY USE AREA TO BEACH TRAIL L.S. PER LUMP SUM

This Alternate item shall consist of all work related to that portion of wood deck, ramps, & stairs extending from the east side of Day Use Building entry and connecting to the beach area trails where shown on Contract Documents. Includes all materials required for construction of this section of wood decking, ramps, stairs, handrails, framing, posts, beams, bracing, diamond pier footings, and connection to Base Bid wood decking at entrance to Day Use Building where shown.

A. If awarded, payment shall be based on a percentage of actual construction completed at time of payment estimate.

**KOPACHUCK STATE PARK
DAY USE DEVELOPMENT**

A2. AMPHITHEATER WOOD DECK, RAMP, STEPS, AND SEATING **L.S. PER LUMP SUM**

This Alternate item shall consist of all work related to constructing the wood amphitheater deck, ramp, steps, and seating located off wood deck/ramp connecting Day Use Building entry to beach area trails (Alternate No. A1) where shown on Contract Documents. Includes all materials required for construction of amphitheater wood decking, ramp, steps, seating, handrails, framing, posts, beams, bracing, diamond pier footings, and connection to Alternate A1 wood decking where shown.

A. If awarded, payment shall be based on a percentage of actual construction completed at time of payment estimate.

A3. WELCOME CENTER WOOD STAIRS **L.S. PER LUMP SUM**

This Alternate item shall consist of all work related to the wood stairs and deck connecting the plaza near the Welcome Center to the play area perimeter path where shown on Contract Documents. Includes all materials required for construction of wood decking, stairs, handrails, framing, posts, beams, bracing, diamond pier footings, and concrete footing shown.

A. If Awarded, payment shall be based on a percentage of actual construction completed at time of payment estimate.

A4. SCHOOL CONNECTOR TRAIL AND SMALL PARKING LOT ALONG 56th ST NW **L.S. PER LUMP SUM**

This Alternate item shall consist of all work related to construction of the trail/pathway and small parking lot shown along the south side of 56th St NW where shown on Contract Documents including, clearing, demolition, grading, surfacing, curbing, paving, striping, signage, landscape, etc.

A. If Awarded, payment shall be based on a percentage of actual construction completed at time of payment estimate.

A5. DAY USE TO BEACH AREA TRAILS **L.S. PER LUMP SUM**

This Alternate item shall consist of all work related to construction of the trail/pathways between the day use area Stair (Alternate A1) to the existing beach area drive where shown on Contract Documents including, clearing, demolition, minor grading, surfacing, landscape steps, etc. (Note: Storm drainage work in this area is included in Base Bid).

A. If Awarded, payment shall be based on a percentage of actual construction completed at time of payment estimate.

**KOPACHUCK STATE PARK
DAY USE DEVELOPMENT**

A6. USE OF ON-SITE SALVAGED WOOD MATERIAL FOR PLAY TOWER STRUCTURE **L.S. PER LUMP SUM**

This Alternate item shall consist use of on-site wood pole material in lieu of purchased wood pole material for construction of the play area tower structure.

- A. If Awarded, payment shall be based on a percentage of actual construction completed at time of payment estimate.

A7. USE OF ON-SITE SALVAGED WOOD MATERIAL FOR PARK ENTRY GATE STRUCTURE **L.S. PER LUMP SUM**

This Alternate item shall consist use of on-site wood pole material in lieu of purchased wood pole material for construction of the park entry gate structure.

- A. If Awarded, payment shall be based on a percentage of actual construction completed at time of payment estimate.

END OF SECTION



KOPACHUCK STATE PARK
DAY USE DEVELOPMENT

BIDS DUE:
1:00PM, THURSDAY,
APRIL 25, 2024

BID DELIVERY LOCATION:

DELIVER BIDS ELECTRONICALLY TO [BIDBOX@PARKS.WA.GOV](mailto:bidbox@parks.wa.gov)

Subject line to read: "SW-C1811 [YOUR COMPANY NAME]."

***** Bid Proposal and Signature: See Sections 7.1 and 11.1 of the Instructions to Bidders for expanded instructions for bid submittal. *****

**** PLEASE PRINT CLEARLY BELOW ****

<h1>TOTAL BASE BID</h1>	
(NOT INCLUDING SALES TAX)	
↓ PRICE WRITTEN-OUT COMPLETELY IN WORDS ↓	↓ PRICE IN NUMBERS ONLY ↓
_____ (U.S.) DOLLARS	\$ _____

Printed Name of Person Signing Bid Proposal ↑	Firm Name (Printed legibly) ↑
Title ↑ (Estimator, Vice-President, Owner, Principal, etc.)	Physical Street Address ↑ (NO PO Boxes Here)
Contractor Registration No. & Expiration Date ↑	City ↑ State Zip + PLUS 4 ()
Taxpayer Identification Number ↑	Area Code Phone Number ↑ ()
Washington UBI Number ↑	Area Code Fax Number ↑ ()
Employment Security Department Number ↑	Area Code Cellular Phone Number ↑ ()
PO Box for US Mail Delivery (if any) ↑	E-Mail Address (Enter N/A if none) ↑



**KOPACHUCK STATE PARK
DAY USE DEVELOPMENT**

Unit prices and estimated quantities shall be used to determine the Base Bid. These prices shall also be used to adjust the Contract in the event there is an increase or decrease in the estimated quantities. All costs shall be “in place” costs and complete, **excluding State Sales Tax.** *In the event of an irregularity, the unit price prevails. The Owner reserves the right to make mathematical corrections of multiplication or addition errors on the bid form.*

Trench Excavation Safety Provisions: If the contract contains any work which requires trenching exceeding a depth of four (4) feet, all costs for adequate trench safety systems shall be identified as a separate bid item in compliance with Chapter 39.04 RCW. The purpose of this provision is to ensure that the bidder agrees to comply with all relevant trench safety requirements of Chapter 49.17 RCW. This bid amount shall be considered part of the total base bid. **Include a lump sum dollar amount (even if the value is \$0.00) to be considered responsive to the bid solicitation.**

Wage Certification. The bidder certifies under penalty of perjury under the laws of the State of Washington that the foregoing is true and correct: within the three-year period immediately preceding the bid solicitation date, the bidder has not been a “willful” violator, as defined in RCW 49.48.082, of any provision of chapters 49.46, 49.48, or 49.52 RCW, as determined by a final and binding citation and notice of assessment issued by the Department of Labor and Industries or through a civil judgment entered by a court of limited or general jurisdiction.

BASE BID ITEMS

BE SURE TO INCLUDE UNIT PRICES IF THE BOX IS NOT SHADED

ITEM NO.	DESCRIPTION	EST QTY	UNIT PRICE	TOTAL AMOUNT
1.	Trench Excavation Safety Provisions	L.S.		
2.	Mobilization	L.S.		
3.	Day Use Area Site Improvements	L.S.		
4.	Park Entry Structure	L.S.		
5.	Play Tower and Log Cabin Structures	L.S.		
6.	Play Area Faux Water Feature	L.S.		
7.	Play Area Imp. Inside Perimeter Path	L.S.		
8.	Day Use Building	L.S.		
9.	Day Use Lower Wood Deck & Stairs	L.S.		
10.	Welcome Center Building	L.S.		
11.	Storm Drainage to Beach Area	L.S.		
12.	Site Security CCTV System	L.S.		
ITEM TOTAL MUST AGREE WITH PAGE 1 BID AMOUNT →				\$



**KOPACHUCK STATE PARK
DAY USE DEVELOPMENT**

ALTERNATE BID ITEMS

ITEM NO.	DESCRIPTION	EST QTY	UNIT PRICE	TOTAL AMOUNT
A1	Wood Deck/Ramp & Stairs Day Use Area to Beach Trail.	L.S.		
A2	Amphitheater Wood Deck, Ramp, Steps, and Seating.	L.S.		
A3	Welcome Center Wood Stairs.	L.S.		
A4	School Connector Trail and Small Parking Lot Along 56 th St NW.	L.S.		
A5	Day Use to Beach Area Trails.	L.S.		
A6	Use of On-Site Salvaged Wood Material for Play Tower Structure.	L.S.		
A7	Use of On-Site Salvaged Wood Material for Park Entry Gate Structure.	L.S.		

Minority and Women’s Business Enterprises (MWBE) Utilization Certification: The bidder certifies they have, in good faith, afforded maximum opportunities to MWBEs, and if they are the successful bidder on this project, the following MWBE firms or approved substitutes shall be utilized on the project. If the bidder does not expect to utilize MWBE firms, enter “N.A.” on line one below.

Firm Name, Address and Federal I.D. #	Telephone Number	Type of Work	Certificate Number	MBE%	WBE%
1					
2					
TOTALS					

Bidder may attach a separate sheet for additional MWBE Utilization Certification.

The Bidder declares that they have carefully examined the site of the proposed work, the Drawings, Specifications and all of the conditions affecting the work. Therefore, the Bidder proposes to provide all labor, equipment, materials, and permits and to perform all work as required by, and in strict accordance with the Contract Documents for the bid amounts as follows.



**KOPACHUCK STATE PARK
DAY USE DEVELOPMENT**

The Commission reserves the right to accept or reject all bids and to waive informalities. No withdrawal of bids after bid deadline, or before award of contract, unless award is delayed over thirty (30) days.

Bidder agrees to complete project (including accepted alternates) in accordance with drawings and specifications within **365** calendar days from the date provided on the Notice to Proceed letter.

It is agreed that liquidated damages, in the amount of **\$1,000.00**, shall be levied for each and every calendar day by which the completion of the work is delayed beyond the time fixed for completion or extension of the contract.

Apprentice Utilization Requirements. The apprentice labor hours required for this project are 15% of the total labor hours. The undersigned agrees to utilize this level of apprentice participation. A monetary incentive of \$1,000.00 will be paid to the contractor meeting the apprentice utilization requirement. A monetary penalty will be applied to the contractor failing to meet the utilization requirement and failing to demonstrate a Good Faith Effort. The penalty will be \$100.00 per percentage point not utilized.

Expected Apprenticeship Utilization cost value to be included in the bid associated with meeting the goals: \$ _____.

Addenda: Receipt of addenda numbered [] through [] is hereby acknowledged.

Signature of Authorized Official



**KOPACHUCK STATE PARK
DAY USE DEVELOPMENT**

SUBCONTRACTORS UTILIZATION LIST

In compliance with the contract documents, the following subcontractor list is submitted:

SUBCONTRACTOR LISTING – RCW 39.30.060

If the base bid and the sum of the additive alternates is one million dollars or more, the Bidder shall provide names of the subcontractors with whom the Bidder will **directly** subcontract for performance of the following work. If the Bidder intends to perform the work, the Bidder must enter its name for that category of work.

- A. Submission Deadline: The completed and signed Subcontractors List must be submitted with bid.
- B. List Subcontractors: The Bidder shall indicate on the Subcontractors List the names of the subcontractors with whom the Bidder, if awarded the contract, will directly subcontract for performance of the work of heating, ventilation, and air conditioning, plumbing as described in Chapter 18.106 RCW, electrical as described in Chapter 19.28 RCW, structural steel installation, and rebar installation.
- C. List Bidder if Bidder Performing Work: If the Bidder will self-perform the work in any of the five areas required, the Bidder shall name itself for the work on the Subcontractors List.
- D. Name Only One Firm for Each Category of Work: The Bidder shall not list more than one firm (subcontractor or Bidder) for each category of work identified, unless subcontractors vary with bid Alternatives or Additives, in which case the Bidder must indicate which firm will be used for which Alternate or Additive.
- E. Substitution of Subcontractors: Substitution of any listed subcontractor may only be according to the procedure and parameters set forth in RCW 39.30.060.
- F. Factors Relating to Non-Responsiveness: **Failure of the Bidder to submit the names of such subcontractors or to name itself to perform such work or the naming of two or more firms (subcontractors or Bidder) to perform the same work shall render the Bidder's bid nonresponsive and, therefore, VOID.**
- G. Applicable to Direct Subcontractors: The requirement of this section to name the Bidders' proposed heating, ventilation and air conditioning, plumbing, electrical, structural steel installation, and rebar installation subcontractors applies only to proposed heating, ventilation and air conditioning, plumbing, electrical, structural steel installation, and rebar installation subcontractors who will contract directly with the Bidder.



**KOPACHUCK STATE PARK
DAY USE DEVELOPMENT**

1. HVAC, Electrical, Plumbing: The requirement of this section to name the bidder's proposed heating, ventilation and air conditioning, plumbing and electrical subcontractors applies only to proposed heating, ventilation, and air conditioning, plumbing and electrical subcontractors who will contract directly with the bidder.

Category of Work	Bidder MUST check one box for each Category of Work. If subcontracting the work, bidder must name the subcontractor.
HVAC (Heating, Ventilation & Air Conditioning)	<input type="checkbox"/> Name of Subcontractor: _____ <input type="checkbox"/> Bidder will self-perform this work, or the project does not include this work.
Electrical	<input type="checkbox"/> Name of Subcontractor: _____ <input type="checkbox"/> Bidder will self-perform this work, or the project does not include this work.
Plumbing	<input type="checkbox"/> Name of Subcontractor: _____ <input type="checkbox"/> Bidder will self-perform this work, or the project does not include this work.

Bidder may attach a separate sheet for additional alternate bid subcontractors

2. Structural Steel Installation and Rebar Installation: The requirement of this section to name the bidder's proposed names of the subcontractors with whom the bidder, if awarded, will subcontract for performance of the work of structural steel installation and rebar installation.

Category of Work	Bidder MUST check one box for each Category of Work. If subcontracting the work, bidder must name the subcontractor.
Structural Steel Installation	<input type="checkbox"/> Name of Subcontractor: _____ <input type="checkbox"/> Bidder will self-perform this work, or the project does not include this work.
Rebar Installation	<input type="checkbox"/> Name of Subcontractor: _____ <input type="checkbox"/> Bidder will self-perform this work, or the project does not include this work.

Bidder may attach a separate sheet for additional alternate bid subcontractors

Signature of Authorized Official

GENERAL CONDITIONS FOR CONSTRUCTION AT WASHINGTON STATE PARKS

<u>Part</u>	<u>Page</u>	<u>Part</u>	<u>Page</u>
PART 1 GENERAL PROVISIONS		5.15 Tests and Inspection	20
1.01	2	5.16 Correction of Nonconforming Work	21
1.02	3	5.17 Clean Up	22
1.03	4	5.18 Access to Work	22
PART 2 INSURANCE AND BONDS		5.19 Other Contracts	22
2.01	4	5.20 Subcontractors and Suppliers	22
2.02	5	5.21 Warranty of Construction	23
2.03	6	5.22 Indemnification	23
2.04	6	PART 6 PAYMENTS AND COMPLETION	
2.05	6	6.01 Contract Sum	24
2.06	6	6.02 Schedule of Values	24
PART 3 TIME AND SCHEDULE		6.03 Application for Payment	24
3.01	7	6.04 Progress Payments	25
3.02	7	6.05 Payments Withheld	25
3.03	8	6.06 Retainage and Bond Claim Rights	25
3.04	8	6.07 Substantial Completion	26
3.05	8	6.08 Prior Occupancy	26
3.06	9	6.09 Final Completion, Acceptance, and Payment	26
3.07	9	PART 7 CHANGES	
PART 4 SPECIFICATIONS, DRAWINGS, AND OTHER DOCUMENTS		7.01 Changes in the Work	27
4.01	10	7.02 Change in the Contract Sum	27
4.02	10	7.03 Change in the Contract Time	32
4.03	10	PART 8 CLAIMS AND DISPUTE RESOLUTION	
4.04	11	8.01 Claims Procedure	34
4.05	11	8.02 Arbitration	35
PART 5 PERFORMANCE		8.03 Claims Audits	35
5.01	12	PART 9 TERMINATION OF THE WORK	
5.02	13	9.01 Termination by Owner for Cause	36
5.03	13	9.02 Termination by Owner for Convenience	37
5.04	13	PART 10 MISCELLANEOUS PROVISIONS	
5.05	14	10.01 Governing Law	38
5.06	14	10.02 Successors and Assigns	38
5.07	15	10.03 Meaning of Words	38
5.08	17	10.04 Rights and Remedies	38
5.09	17	10.05 Contractor Registration	38
5.10	18	10.06 Time Computations	38
5.11	18	10.07 Records Retention	38
5.12	19	10.08 Third-Party Agreements	39
5.13	19	10.09 Antitrust Assignment	39
5.14	20	10.10 Minority & Women's Business Enterprises (MWBE) Participation	39
		10.11 Minimum Levels of Apprenticeship Participation	40
		10.12 Headings and Captions	41

GENERAL CONDITIONS FOR CONSTRUCTION AT WASHINGTON STATE PARKS

PART 1 - GENERAL PROVISIONS

1.01 DEFINITIONS

- A. "Application for Payment" means a written request submitted by Contractor to A/E for payment of Work completed in accordance with the Contract Documents and approved Schedule of Values, supported by such substantiating data as Owner or A/E may require.
- B. "Architect," "Engineer," or "A/E" shall mean that person designated by the State Parks and Recreation Commission to be in charge of the work covered by this contract.
- C. "Change Order" means a written instrument signed by Owner and Contractor stating their agreement upon all of the following: (1) a change in the Work; (2) the amount of the adjustment in the Contract Sum, if any, and (3) the extent of the adjustment in the Contract Time, if any.
- D. "Claim" means Contractor's exclusive remedy for resolving disputes with Owner regarding the terms of a Change Order or a request for equitable adjustment, as more fully set forth in part 8.
- E. "Contract Award Amount" is the sum of the Base Bid and any accepted Alternates.
- F. "Contract Documents" means the Advertisement for Bids, Instructions for Bidders, completed Form of Proposal, General Conditions, Modifications to the General Conditions, Supplemental Conditions, Public Works Contract, other Special Forms, Drawings and Specifications, and all addenda and modifications thereof.
- G. "Contract Sum" is the total amount payable by Owner to Contractor for performance of the Work in accordance with the Contract Documents, including all taxes imposed by law and properly chargeable to the Work, except Washington State sales tax.
- H. "Contract Time" is the number of calendar days allotted in the Contract Documents for achieving Substantial Completion of the Work.
- I. "Contractor" means the person or entity who has agreed with Owner to perform the Work in accordance with the Contract Documents.
- J. "Drawings" are the graphic and pictorial portions of the Contract Documents showing the design, location, and dimensions of the Work, and may include plans, elevations, sections, details, schedules, and diagrams.
- K. "Final Acceptance" means the written acceptance issued to Contractor by Owner after Contractor has completed the requirements of the Contract Documents, as more fully set forth in Section 6.09 B.
- L. "Final Completion" means that the Work is fully and finally completed in accordance with the Contract Documents, as more fully set forth in Section 6.09 A.
- M. "Force Majeure" means those acts entitling Contractor to request an equitable adjustment in the Contract Time, as more fully set forth in paragraph 3.05 A.
- N. "Notice" means a written notice which has been delivered in person to the individual or a member of the firm or entity or to an officer of the corporation for which it was intended or, if delivered or sent by registered or certified mail, to the last business address known to the party giving notice.
- O. "Notice to Proceed" means a notice from Owner to Contractor that defines the date on which the Contract Time begins to run.
- P. "Owner" shall mean the Washington State Parks and Recreation Commission and its authorized representative with the authority to enter into, administer and/or terminate contracts and make related determinations and findings.
- Q. "Person" means a corporation, partnership, business association of any kind, trust, company, or individual.

GENERAL CONDITIONS FOR CONSTRUCTION AT WASHINGTON STATE PARKS

- R. "Prior Occupancy" means Owner's use of all or parts of the Project before Substantial Completion, as more fully set forth in Section 6.08 A.
- S. "Progress Schedule" means a schedule of the Work, in a form satisfactory to Owner, as further set forth in section 3.02.
- T. "Project" means the total construction of which the Work performed in accordance with the Contract Documents may be the whole or a part and which may include construction by Owner or by separate contractors.
- U. "Project Manual" means the volume usually assembled for the Work which may include the bidding requirements, sample forms, and other Contract Documents.
- V. "Project Record" means the separate set of Drawings and Specifications as further set forth in paragraph 4.02A.
- W. "Schedule of Values" means a written breakdown allocating the total Contract Sum to each principle category of Work, in such detail as requested by Owner.
- X. "Specifications" are that portion of the Contract Documents consisting of the written requirements for materials, equipment, construction systems, standards, and workmanship for the Work, and performance of related services.
- Y. "Subcontract" means a contract entered into by Subcontractor for the purpose of obtaining supplies, materials, equipment, or services of any kind for or in connection with the Work.
- Z. "Subcontractor" means any person, other than Contractor, who agrees to furnish or furnishes any supplies, materials, equipment, or services of any kind in connection with the Work.
- AA. "Substantial Completion" means that stage in the progress of the Work where Owner has full and unrestricted use and benefit of the facilities for the purposes intended, as more fully set forth in section 6.07.
- AB. "Work" means the construction and services required by the Contract Documents, and includes, but is not limited to, labor, materials, supplies, equipment, services, permits, and the manufacture and fabrication of components, performed, furnished, or provided in accordance with the Contract Documents.

1.02 ORDER OF PRECEDENCE

Any conflict or inconsistency in the Contract Documents shall be resolved by giving the documents precedence in the following order.

1. Signed Public Works Contract, including any Change Orders, and any Special Forms.
2. Supplemental Conditions.
3. General Conditions.
4. Addenda
5. Specifications--provisions in Division 1 shall take precedence over provisions of any other Division.
6. Drawings--in case of conflict within the Drawings, large scale drawings shall take precedence over small scale drawings.
7. Signed and Completed Form of Proposal.
8. Instructions to Bidders.
9. Advertisement for Bids.

GENERAL CONDITIONS FOR CONSTRUCTION AT WASHINGTON STATE PARKS

1.03 EXECUTION AND INTENT

Contractor makes the following representations to Owner:

1. The Contract Sum is reasonable compensation for the Work and the Contract Time is adequate for the performance of the Work, as represented by the Contract Documents;
2. Contractor has carefully reviewed the Contract Documents, visited and examined the Project site, become familiar with the local conditions in which the Work is to be performed, and satisfied itself as to the nature, location, character, quality and quantity of the Work, the labor, materials, equipment, goods, supplies, work, services and other items to be furnished and all other requirements of the Contract Documents, as well as the surface and subsurface conditions and other matters that may be encountered at the Project site or affect performance of the Work or the cost or difficulty thereof;
3. Contractor is financially solvent, able to pay its debts as they mature, and possesses sufficient working capital to complete the Work and perform Contractor's obligations required by the Contract Documents; and
4. Contractor is able to furnish the plant, tools, materials, supplies, equipment and labor required to complete the Work and perform the obligations required by the Contract Documents and has sufficient experience and competence to do so.

PART 2 - INSURANCE AND BONDS

2.01 CONTRACTOR'S LIABILITY INSURANCE

Prior to commencement of the Work, Contractor shall obtain all the insurance required by the Contract Documents and provide evidence satisfactory to Owner that such insurance has been procured. Review of the Contractor's insurance by Owner shall not relieve or decrease the liability of Contractor. Companies writing the insurance to be obtained by this part shall be licensed to do business under Chapter 48 RCW or comply with the Surplus Lines Law of the State of Washington. Contractor shall include in its bid the cost of all insurance and bond costs required to complete the base bid work and accepted alternates. Insurance carriers providing insurance in accordance with the Contract Documents shall be acceptable to Owner, and its A. M. Best rating shall be indicated on the insurance certificates.

- A. Contractor shall maintain the following insurance coverage during the Work and for one year after Final Acceptance. Contractor shall also maintain the following insurance coverage during the performance of any corrective Work required by section 5.16.
 1. Commercial General Liability (CGL) on an Occurrence Form:
 - a. Completed operations/products liability;
 - b. Explosion, collapse, and underground; and
 - c. Employer's liability coverage.
 2. Automobile liability
- B. Contractor shall comply with the Washington State Industrial Insurance Act and, if applicable, the Federal Longshoremen's and Harbor Workers' Act and the Jones Act.
- C. All insurance coverages shall protect against claims for damages for personal and bodily injury or death, as well as claims for property damage, which may arise from operations in connection with the Work whether such operations are by Contractor or any Subcontractor.
- D. All insurance coverages shall be endorsed to include Owner as an additional named insured for Work performed in accordance with the Contract Documents, and all insurance certificates shall evidence the Owner as an additional insured.

GENERAL CONDITIONS FOR CONSTRUCTION AT WASHINGTON STATE PARKS

2.02 COVERAGE LIMITS INSURANCE COVERAGE CERTIFICATES

A. Insurance Coverage Certificates

The Contractor shall furnish acceptable proof of insurance coverage on the State of Washington Certificate of Insurance form SF500A dated 07/02/92 or an acceptable ACORD form.

B. Required Coverages

1. For a contract less than \$100,000.00, the coverage required is:

a. Public Liability Insurance – The Contractor shall at all times during the term of this contract, at its cost and expense, carry and maintain general public liability insurance, including contractual liability, against claims for bodily injury, personal injury, death or property damage occurring or arising out of services provided under this contract. This insurance shall cover claims caused by any act, omission, or negligence of the Contractor or its officers, agents, representatives, assigns or servants. The limits of liability insurance, which may be increased as deemed necessary by the contracting parties, shall be:

Each Occurrence	\$1,000,000.00
General Aggregate Limits (other than products – commercial operations)	\$1,000,000.00
Products – Commercial Operations Limit	\$1,000,000.00
Personal and Advertising Injury Limit	\$1,000,000.00
Fire Damage Limit (any one fire)	\$50,000.00
Medical Expense Limit (any one person)	\$5,000.00

b. If the contract is for underground utility work, then the Contractor shall provide proof of insurance for that above in the form of Explosion, Collapse and Underground (XCU) coverage.

c. Employers Liability on an occurrence basis in an amount not less than \$1,000,000.00 per occurrence.

2. For contracts over \$100,000.00 but less than \$5,000,000.00 the contractor shall obtain the coverage limits as listed for contracts below \$100,000.00 and General Aggregate and Products – Commercial Operations Limit of not less than \$2,000,000.00.

3. Coverage for Comprehensive General Bodily Injury Liability Insurance for a contract over \$5,000,000.00 is:

Each Occurrence	\$2,500,000.00
General Aggregate Limits (other than products – commercial operations)	\$5,000,000.00
Products – Commercial Operations limit	\$5,000,000.00
Personal and Advertising Injury Limit	\$2,500,000.00
Fire Damage Limit (any one fire)	\$50,000.00
Medical Expense Limit (any one Person)	\$5,000.00

4. For all Contracts – Automobile Liability: in the event that services delivered pursuant to this contract involve the use of vehicles or the transportation of clients, automobile liability insurance shall be required. If Contractor-owned personal vehicles are used, a Business Automobile Policy covering at a minimum Code 2 “owned autos only” must be secured. If Contractor employee’s vehicles are used, the Contractor must also include under the Business Automobile Policy Code 9, coverage for non-owned autos. The minimum limits for automobile liability is: \$1,000,000.00 per occurrence, using a combined single limit for bodily injury and property damage.

5. For Contracts for Hazardous Substance Removal (Asbestos Abatement, PCB Abatement, etc.)

a. In addition to providing insurance coverage for the project as outlined above, the Contractor shall provide Environmental Impairment Liability insurance for the hazardous substance removal as follows:

<u>EACH OCCURRENCE</u>	<u>AGGREGATE</u>
\$500,000.00	\$1,000,000.00

or \$1,000,000.00 each occurrence/aggregate bodily injury and property damage combined single limit.

GENERAL CONDITIONS FOR CONSTRUCTION AT WASHINGTON STATE PARKS

- 1) Insurance certificate must state that the insurer is covering hazardous substance removal.
- 2) Should this insurance be secured on a "claims made" basis, the coverage must be continuously maintained for one year following the project's "final completion" through official completion of the project, plus one year following.

For Contracts where hazardous substance removal is a subcomponent of contracted work, the general contractor shall provide to the Owner a certificate of insurance for coverage as defined in 5a. above. The State of Washington must be listed as an additional insured. This certificate of insurance must be provided to the Owner prior to commencing work.

2.03 INSURANCE COVERAGE CERTIFICATES

- A. Prior to commencement of the Work, Contractor shall furnish to Owner a completed certificate of insurance coverage.
- B. All insurance certificates shall name Owner's Project number and Project title.
- C. All insurance certificates shall specifically require 45 (forty-five) days prior notice to Owner of cancellation or any material change, except 30 (thirty) days for surplus line insurance.

2.04 PAYMENT AND PERFORMANCE BONDS

AIA Payment and Performance Bonds, form A312, or equivalent, is required by the Owner for the work of this contract. The forms shall be obtained from the Contractor's bonding company. The Payment Bond shall cover payment to laborers and mechanics, including payments to Employee Benefit Funds, and payments to subcontractors, material suppliers, and persons who shall supply such person or persons, or subcontractors with materials and supplies.

2.05 ALTERNATIVE SURETY

Contractor shall promptly furnish alternative security required to protect Owner and persons supplying labor or materials required by the Contract Documents if:

- A. Owner has a reasonable objection to the surety; or
- B. Any surety fails to furnish reports on its financial condition if requested by Owner.

2.06 BUILDER'S RISK

- A. Contractor shall purchase and maintain property insurance in the amount of the Contract Sum including all Change Orders for the Work on a replacement cost basis until Substantial Completion. The insurance shall cover the interest of Owner, Contractor, and any Subcontractors, as their interests may appear. For projects not involving New Building Construction, 'Installation Floater' is an acceptable substitute for the Builder's Risk Insurance.
- B. Contractor property insurance shall be placed on an "all risk" basis and insure against the perils of fire and extended coverage and physical loss or damage including theft, vandalism, malicious mischief, collapse, false work, temporary buildings, debris removal including demolition occasioned by enforcement of any applicable legal requirements, and shall cover reasonable compensation for A/E's services and expenses required as a result of an insured loss.
- C. Owner and Contractor waive all subrogation rights against each other, any Subcontractors, A/E, A/E's subconsultants, separate contractors described in section 5.20, if any, and any of their subcontractors, for damages caused by fire or other perils to the extent covered by property insurance obtained pursuant to this section or other property insurance applicable to the Work, except such rights as they have to proceeds of such insurance held by Owner as fiduciary. The policies shall provide such waivers of subrogation by endorsement or otherwise. A waiver of subrogation shall be effective to a person or entity even though that person or entity would otherwise have a duty of indemnification, contractual or otherwise, did not pay the insurance premium directly or indirectly, and whether or not the person or entity had an insurable interest in the property damaged.

GENERAL CONDITIONS FOR CONSTRUCTION AT WASHINGTON STATE PARKS

PART 3 - TIME AND SCHEDULE

3.01 PROGRESS AND COMPLETION

- A. Contractor shall diligently prosecute the Work, with adequate forces, achieve Substantial Completion within the Contract Time, and achieve Final Completion within 30 (thirty) calendar days thereafter, unless otherwise noted in Division 1 of the specifications.
- B. The Contractor shall notify the Engineer at least two (2) weekdays in advance if work is to be performed on a Saturday, Sunday, or legal holiday. No excavation work will be allowed on Saturdays, Sundays, or legal holidays unless specifically authorized by the Engineer.

3.02 CONSTRUCTION SCHEDULE

- A. Unless otherwise provided in Division 1, Contractor shall, within 14 (fourteen) calendar days after issuance of the Notice to Proceed, submit a preliminary Progress Schedule. The Progress Schedule shall show the sequence in which Contractor proposes to perform the Work, and the dates on which Contractor plans to start and finish major portions of the Work, including dates for shop drawings and other submittals, and for acquiring materials and equipment.
- B. The Progress Schedule shall be in the form of a Critical Path Method (CPM) logic network or, with the approval of the Owner, a bar chart schedule may be submitted. The scheduling of construction is the responsibility of the Contractor and is included in the contract to assure adequate planning and execution of the work. The schedule will be used to evaluate progress of the work for payment based on the Schedule of Values. The schedule shall show the Contractor's planned order and interdependence of activities, and sequence of work. As a minimum the schedule shall include:
 - 1. Date of Notice to Proceed;
 - 2. Activities (resources, durations, individual responsible for activity, early starts, late starts, early finishes, late finishes, etc.);
 - 3. Utility Shutdowns;
 - 4. Interrelationships and dependence of activities;
 - 5. Planned vs. actual status for each activity;
 - 6. Substantial completion;
 - 7. Punch list;
 - 8. Final inspection;
 - 9. Final completion, and
 - 10. Float time

The Schedule Duration shall be based on the Contract Time of Completion listed on the Bid Proposal form. The Owner shall not be obligated to accept any Early Completion Schedule suggested by the Contractor. The Contract Time for Completion shall establish the Schedule Completion Date.

If the Contractor feels that the work can be completed in less than the Specified Contract Time, then the Surplus Time shall be considered Project Float. This Float time shall be shown on the Project Schedule. It shall be available to accommodate changes in the work and unforeseen conditions.

Neither the Contractor nor the Owner have exclusive right to this Float Time. It belongs to the project.

- C. Owner shall return comments on the preliminary Progress Schedule to Contractor within 14 (fourteen) days of receipt. Review by Owner of Contractor's schedule does not constitute an approval or acceptance of Contractor's construction means, methods, or sequencing, or its ability to complete the Work within the Contract Time. Contractor shall revise and resubmit its schedule, as necessary. Owner may withhold a portion of progress payments until a Progress Schedule has been submitted which meets the requirements of this section.
- D. Contractor shall utilize and comply with the Progress Schedule. On a monthly basis, or as otherwise directed by Owner, Contractor shall submit an updated Progress Schedule at its own expense to Owner indicating actual progress. If, in the opinion of Owner, Contractor is not in conformance with the Progress Schedule for reasons other than acts of Force Majeure as identified in section 3.05, Contractor shall take

GENERAL CONDITIONS FOR CONSTRUCTION AT WASHINGTON STATE PARKS

such steps as are necessary to bring the actual completion dates of its work activities into conformance with the Progress Schedule, or revise the Progress Schedule to reconcile with the actual progress of the Work.

- E. Contractor shall promptly notify Owner in writing of any actual or anticipated event which is delaying or could delay achievement of any milestone or performance of any critical path activity of the Work. Contractor shall indicate the expected duration of the delay, the anticipated effect of the delay on the Progress Schedule, and the action being or to be taken to correct the problem. Provision of such notice does not relieve Contractor of its obligation to complete the Work within the Contract Time.

3.03 OWNER'S RIGHT TO SUSPEND THE WORK FOR CONVENIENCE

- A. Owner may, at its sole discretion, order Contractor, in writing, to suspend all or any part of the Work for up to 90 (ninety) days, or for such longer period as mutually agreed.
- B. Upon receipt of a written notice suspending the Work, Contractor shall immediately comply with its terms and take all reasonable steps to minimize the incurrence of cost of performance directly attributable to such suspension. Within a period up to 90 (ninety) days after the notice is delivered to Contractor, or within any extension of that period to which the parties shall have agreed, Owner shall either:
 - 1. Cancel the written notice suspending the Work; or
 - 2. Terminate the Work covered by the notice as provided in the termination provisions as more fully set forth in Part 9.
- C. If a written notice suspending the Work is cancelled or the period of the notice or any extension thereof expires, Contractor shall resume Work.
- D. Contractor shall be entitled to an equitable adjustment in the Contract Time, or Contract Sum, or both, for increases in the time or cost of performance directly attributable to such suspension, provided Contractor complies with all requirements set forth in Part 7.

3.04 OWNER'S RIGHT TO STOP THE WORK FOR CAUSE

- A. If Contractor fails or refuses to perform its obligations in accordance with the Contract Documents, Owner may order Contractor, in writing, to stop the Work, or any portion thereof, until satisfactory corrective action has been taken.
- B. Contractor shall not be entitled to an equitable adjustment in the Contract Time or Contract Sum for any increased cost or time of performance attributable to Contractor's failure or refusal to perform or from any reasonable remedial action taken by Owner based upon such failure.

3.05 DELAY

- A. Any delay in or failure of performance by Owner or Contractor, other than the payment of money, shall not constitute a default hereunder if and to the extent the cause for such delay or failure of performance was unforeseeable and beyond the control of the party ("Force Majeure"). Acts of Force Majeure include, but are not limited to:
 - 1. Acts of God or the public enemy;
 - 2. Acts or omissions of any government entity;
 - 3. Fire or other casualty for which Contractor is not responsible;
 - 4. Quarantine or epidemic;
 - 5. Strike or defensive lockout;
 - 6. Unusually severe weather, in excess of weather conditions which could not have been reasonably anticipated; and

GENERAL CONDITIONS FOR CONSTRUCTION AT WASHINGTON STATE PARKS

7. Unusual delay in receipt of supplies or products which were ordered and expedited and for which no substitute reasonably acceptable to Owner was available.
- B. Contractor shall be entitled to an equitable adjustment in the Contract Time for changes in the time of performance directly attributable to an act of Force Majeure, provided it makes a request for equitable adjustment according to section 7.03. Contractor shall not be entitled to an adjustment in the Contract Sum resulting from an act of Force Majeure.
- C. Contractor shall be entitled to an equitable adjustment in Contract Time, and may be entitled to an equitable adjustment in Contract Sum, if the cost or time of Contractor's performance is changed due to the fault or negligence of Owner, provided the Contractor makes a request according to sections 7.02 and 7.03.
- D. Contractor shall not be entitled to an adjustment in Contract Time or in the Contract Sum for any delay or failure of performance to the extent such delay or failure was caused by Contractor or anyone for whose acts Contractor is responsible.
- E. To the extent any delay or failure of performance was concurrently caused by the Owner and Contractor, Contractor shall be entitled to an adjustment in the Contract Time for that portion of the delay or failure of performance that was concurrently caused, provided it makes a request for equitable adjustment according to section 7.03, but shall not be entitled to an adjustment in Contract Sum.
- F. Contractor shall make all reasonable efforts to prevent and mitigate the effects of any delay, whether occasioned by an act of Force Majeure or otherwise.
- G. The Owner has acquired ownership and/or easement of lands for the construction, as indicated on the drawings, without cost to the Contractor. The Contractor understands and agrees that, should it appear at any time that the Owner has not acquired title to all of the right-of-ways and lands necessary for the performance of the work under the provisions of this contract, and that if any delay in the performance of said work occasioned by the failure of the Owner, its officers, or employees to acquire a title of any of said lands or right-of-way, such failure shall extend the contract completion date the number of days equal to the period of such delay. The Contractor waives any and all claims for damages against the Owner which the Contractor may sustain by reason of this delay in the work.

3.06 NOTICE TO OWNER OF LABOR DISPUTES

- A. If Contractor has knowledge that any actual or potential labor dispute is delaying or threatens to delay timely performance in accordance with the Contract Documents, Contractor shall immediately give notice, including all relevant information, to Owner.
- B. Contractor agrees to insert a provision in its Subcontracts and to require insertion in all sub-subcontracts, that in the event timely performance of any such contract is delayed or threatened by delay by any actual or potential labor dispute, the Subcontractor or Sub-subcontractor shall immediately notify the next higher tier Subcontractor or Contractor, as the case may be, of all relevant information concerning the dispute.

3.07 DAMAGES FOR FAILURE TO ACHIEVE TIMELY COMPLETION

- A. Liquidated Damages
1. Timely performance and completion of the Work is essential to Owner and time limits stated in the Contract Documents are of the essence. Owner will incur serious and substantial damages if Substantial Completion of the Work does not occur within the Contract Time. However, it would be difficult if not impossible to determine the exact amount of such damages. Consequently, provisions for liquidated damages are included in the Contract Documents.
 2. The liquidated damage amounts set forth in the Contract Documents will be assessed not as a penalty, but as liquidated damages for breach of the Contract Documents. This amount is fixed and agreed upon by and between the Contractor and Owner because of the impracticability and extreme difficulty of fixing and ascertaining the actual damages the Owner would in such event sustain. This amount shall be construed as the actual amount of damages sustained by the Owner, and may be retained by the Owner and deducted from periodic payments to the Contractor.

GENERAL CONDITIONS FOR CONSTRUCTION AT WASHINGTON STATE PARKS

3. Assessment of liquidated damages shall not release Contractor from any further obligations or liabilities pursuant to the Contract Documents.

B. Actual Damages

Actual damages will be assessed for failure to achieve Final Completion within the time provided. Actual damages will be calculated on the basis of direct architectural, administrative, and other related costs attributable to the Project from the date when Final Completion should have been achieved, based on the date Substantial Completion is actually achieved, to the date Final Completion is actually achieved. Owner may offset these costs against any payment due Contractor.

PART 4 - SPECIFICATIONS, DRAWINGS, AND OTHER DOCUMENTS

4.01 DISCREPANCIES AND CONTRACT DOCUMENT REVIEW

- A. The intent of the Specifications and Drawings is to describe a complete Project to be constructed in accordance with the Contract Documents. Contractor shall furnish all labor, materials, equipment, tools, transportation, permits, and supplies, and perform the Work required in accordance with the Drawings, Specifications, and other provisions of the Contract Documents.
- B. The Contract Documents are complementary. What is required by one part of the Contract Documents shall be binding as if required by all. Anything mentioned in the Specifications and not shown on the Drawings, or shown on the Drawings and not mentioned in the Specifications, shall be of like effect as if shown or mentioned in both.
- C. Contractor shall carefully study and compare the Contract Documents with each other and with information furnished by Owner. If, during the performance of the Work, Contractor finds a conflict, error, inconsistency, or omission in the Contract Documents, it shall promptly and before proceeding with the Work affected thereby, report such conflict, error, inconsistency, or omission to A/E in writing.
- D. Contractor shall do no Work without applicable Drawings, Specifications, or written modifications, or Shop Drawings where required, unless instructed to do so in writing by Owner. If Contractor performs any construction activity, and it knows or reasonably should have known that any of the Contract Documents contain a conflict, error, inconsistency, or omission, Contractor shall be responsible for the performance and shall bear the cost for its correction.
- E. Contractor shall provide any work or materials the provision of which is clearly implied and is within the scope of the Contract Documents even if the Contract Documents do not mention them specifically.
- F. Questions regarding interpretation of the requirements of the Contract Documents shall be referred to the A/E.

4.02 PROJECT RECORD

- A. Contractor shall legibly mark in ink on a separate set of the Drawings and Specifications all actual construction, including depths of foundations, horizontal and vertical locations of internal and underground utilities and appurtenances referenced to permanent visible and accessible surface improvements, field changes of dimensions and details, actual suppliers, manufacturers and trade names, models of installed equipment, and Change Order Proposals (COP). This separate set of Drawings and Specifications shall be the "Project Record."
- B. The Project Record shall be maintained on the project site throughout the construction and shall be clearly labeled "PROJECT RECORD". The Project Record shall be updated at least weekly noting all changes and shall be available to Owner at all times.
- C. Contractor shall submit the completed and finalized Project Record to A/E prior to Final Acceptance.

4.03 SUBMITTALS

- A. "Submittals" means documents and other information required to be submitted to A/E by Contractor pursuant to the Contract Documents, showing in detail: the proposed fabrication and assembly of structural

GENERAL CONDITIONS FOR CONSTRUCTION AT WASHINGTON STATE PARKS

elements; and the installation (i.e. form, fit, and attachment details) of materials and equipment. Submittals include, but are not limited to, drawings, diagrams, layouts, schematics, descriptive literature, illustrations, schedules, performance and test data, samples, and similar materials furnished by Contractor to explain in detail specific portions of the Work required by the Contract Documents. For materials and equipment to be incorporated into the Work, Contractor submittal shall include the name of the manufacturer, the model number, and other information concerning the performance, capacity, nature, and rating of the item. When directed, Contractor shall submit all samples at its own expense. Owner may duplicate, use, and disclose Submittals provided in accordance with the Contract Documents.

- B. Contractor shall coordinate all Shop Drawings, and review them for accuracy, completeness, and compliance with the Contract Documents and shall indicate its approval thereon as evidence of such coordination and review. Where required by law, Shop Drawings shall be stamped by an appropriate professional licensed by the state of Washington. Shop Drawings submitted to A/E without evidence of Contractor's approval shall be returned for resubmission. Contractor shall review, approve, and submit Shop Drawings with reasonable promptness and in such sequence as to cause no delay in the Work or in the activities of Owner or separate contractors. Contractor's submittal schedule shall allow a reasonable time for A/E review. A/E will review, approve, or take other appropriate action on the Shop Drawings. Contractor shall perform no portion of the Work requiring submittal and review of Shop Drawings until the respective submittal has been reviewed and the A/E has approved or taken other appropriate action. Owner and A/E shall respond to Shop Drawing submittals with reasonable promptness. Any Work by Contractor shall be in accordance with reviewed Shop Drawings. Submittals made by Contractor which are not required by the Contract Documents may be returned without action.
- C. Approval, or other appropriate action with regard to Submittals, by Owner or A/E shall not relieve Contractor of responsibility for any errors or omissions in such Submittals, nor from responsibility for compliance with the requirements of the Contract Documents. Unless specified in the Contract Documents, review by Owner or A/E shall not constitute an approval of the safety precautions employed by Contractor during construction, or constitute an approval of Contractor's means or methods of construction. If Contractor fails to obtain approval before installation and the item or work is subsequently rejected, Contractor shall be responsible for all costs of correction.
- D. If Shop Drawings show variations from the requirements of the Contract Documents, Contractor shall describe such variations in writing, separate from the Shop Drawings, at the time it submits the Shop Drawings containing such variations. If A/E approves any such variation, an appropriate Change Order will be issued. If the variation is minor and does not involve an adjustment in the Contract Sum or Contract Time, a Change Order need not be issued; however, the modification shall be recorded upon the Project Record.
- E. Unless otherwise provided in Division I, Contractor shall submit to A/E for approval 5 (five) copies of all Submittals. Unless otherwise indicated, 3 (three) sets of all Submittals shall be retained by A/E and 2 (two) sets shall be returned to Contractor.

4.04 ORGANIZATION OF SPECIFICATIONS

Specifications are prepared in sections which conform generally with trade practices. These sections are for Owner and Contractor convenience and shall not control Contractor in dividing the Work among the Subcontractors or in establishing the extent of the Work to be performed by any trade.

4.05 OWNERSHIP AND USE OF DRAWINGS, SPECIFICATIONS, AND OTHER DOCUMENTS

- A. The Drawings, Specifications, and other documents prepared by A/E are instruments of A/E's service through which the Work to be executed by Contractor is described. Neither Contractor nor any Subcontractor shall own or claim a copyright in the Drawings, Specifications, and other documents prepared by A/E, and A/E shall be deemed the author of them and will, along with any rights of Owner, retain all common law, statutory, and other reserved rights, in addition to the copyright. All copies of these documents, except Contractor's set, shall be returned or suitably accounted for to A/E, on request, upon completion of the Work.
- B. The Drawings, Specifications, and other documents prepared by the A/E, and copies thereof furnished to Contractor, are for use solely with respect to this Project. They are not to be used by Contractor or any

GENERAL CONDITIONS FOR CONSTRUCTION AT WASHINGTON STATE PARKS

Subcontractor on other projects or for additions to this Project outside the scope of the Work without the specific written consent of Owner and A/E. Contractor and Subcontractors are granted a limited license to use and reproduce applicable portions of the Drawings, Specifications, and other documents prepared by A/E appropriate to and for use in the execution of their Work.

- C. Contractor and all Subcontractors grant a non-exclusive license to Owner, without additional cost or royalty, to use for its own purposes (including reproduction) all Shop Drawings, together with the information and diagrams contained therein, prepared by Contractor or any Subcontractor. In providing Shop Drawings, Contractor and all Subcontractors warrant that they have authority to grant to Owner a license to use the Shop Drawings, and that such license is not in violation of any copyright or other intellectual property right. Contractor agrees to defend and indemnify Owner pursuant to the indemnity provisions in section 5.03 and 5.23 from any violations of copyright or other intellectual property rights arising out of Owner's use of the Shop Drawings hereunder, or to secure for Owner, at Contractor's own cost, licenses in conformity with this section.
- D. The Shop Drawings and other submittals prepared by Contractor, Subcontractors of any tier, or its or their equipment or material suppliers, and copies thereof furnished to Contractor, are for use solely with respect to this Project. They are not to be used by Contractor or any Subcontractor of any tier, or material or equipment supplier, on other projects or for additions to this Project outside the scope of the Work without the specific written consent of Owner. The Contractor, Subcontractors of any tier, and material or equipment suppliers are granted a limited license to use and reproduce applicable portions of the Shop Drawings and other submittals appropriate to and for use in the execution of their Work under the Contract Documents.

PART 5 - PERFORMANCE

5.01 CONTRACTOR CONTROL AND SUPERVISION

- A. Contractor shall supervise and direct the Work, using its best skill and attention, and shall perform the Work in a skillful manner. Contractor shall be solely responsible for and have control over construction means, methods, techniques, sequences, and procedures and for coordinating all portions of the Work, unless the Contract Documents give other specific instructions concerning these matters. Contractor shall disclose its means and methods of construction when requested by Owner.
- B. Performance of the Work shall be directly supervised by a competent superintendent who is satisfactory to Owner and has authority to act for Contractor. The superintendent shall not be changed without the prior written consent of Owner. Owner may require Contractor to remove the superintendent from the Work or Project site, if Owner reasonably deems the superintendent incompetent, careless, or otherwise objectionable, provided Owner has first notified Contractor in writing and allowed a reasonable period for transition. The superintendent shall be on-site at all times while the Work is being performed, unless approved in writing by owner, in advance.
- C. Contractor shall be responsible to Owner for acts and omissions of Contractor, Subcontractors, and their employees and agents.
- D. Contractor shall enforce strict discipline and good order among Contractor's employees and other persons performing the Work. Contractor shall not permit employment of persons not skilled in tasks assigned to them. Contractor's employees shall at all times conduct business in a manner which assures fair, equal, and nondiscriminatory treatment of all persons. Owner may, by written notice, request Contractor to remove from the Work or Project site any employee Owner reasonably deems incompetent, careless, or otherwise objectionable.
- E. Contractor shall, at all times, keep on the Project site a copy of the Drawings, Specifications, addenda, reviewed Shop Drawings, permits, and permit drawings.
- F. Contractor shall ensure that its owner(s) and employees, and those of its Subcontractors, comply with the Ethics in Public Service Act RCW 42.52, which, among other things, prohibits state employees from having an economic interest in any public works contract that was made by, or supervised by, that employee. Contractor shall remove, at its sole cost and expense, any of its, or its Subcontractors', employees, if they are in violation of this act.

GENERAL CONDITIONS FOR CONSTRUCTION AT WASHINGTON STATE PARKS

5.02 PERMITS, FEES, AND NOTICES

- A. The Owner has obtained a Shorelines Substantial Development Permit and/or other environmental permits as required for this project. The permits with provisions which affect the construction methods or schedule have been incorporated into these specifications. The Contractor shall abide by all restrictions noted in these permits as the construction is in progress.
- B. All other permits or fees required by local, state or federal governmental agencies necessary for the construction of this project shall be obtained and paid by the Contractor. Only the cost for the building permit will be reimbursed by the Owner.
- C. The Contractor shall conform to all local, State and National Codes in all phases of this project. Where conflicts arise between plans, specifications and code requirements, the code shall prevail unless the plans or specifications are more stringent.

5.03 PATENTS AND ROYALTIES

Contractor is responsible for, and shall pay, all royalties and license fees. Contractor shall defend, indemnify, and hold Owner harmless from any costs, expenses, and liabilities arising out of the infringement by Contractor of any patent, copyright, or other intellectual property right used in the Work; however, provided that Contractor gives prompt notice, Contractor shall not be responsible for such defense or indemnity when a particular design, process, or product of a particular manufacturer or manufacturers is required by the Contract Documents. If Contractor has reason to believe that use of the required design, process, or product constitutes an infringement of a patent or copyright, it shall promptly notify Owner of such potential infringement.

5.04 PREVAILING WAGES

- A. Contractor and all subcontractors shall pay the prevailing rate of wages to all workers, laborers, or mechanics employed in the performance of any part of the Work in accordance with RCW 39.12 and the rules and regulations of the Department of Labor and Industries. The schedule of prevailing wage rates for the locality or localities of the Work is determined by the Industrial Statistician of the Department of Labor and Industries. It is the Contractor's responsibility to verify the applicable prevailing wage rate.
- B. Before payment is made by the Owner to the Contractor for any work performed by the Contractor and subcontractors whose work is included in the application for payment, the Contractor shall submit, or shall have previously submitted to the Owner for the Project, a Statement of Intent to Pay Prevailing Wages, approved by the Department of Labor and Industries, certifying the rate of hourly wage paid and to be paid each classification of laborers, workers, or mechanics employed upon the Work by Contractor and Subcontractors. Such rates of hourly wage shall not be less than the prevailing wage rate.
- C. Prior to release of retainage, the Contractor shall submit to the Owner an Affidavit of Wages Paid, approved by the Department of Labor and Industries, for the Contractor and every subcontractor, of any tier, that performed work on the Project.
- D. Disputes regarding prevailing wage rates shall be referred for arbitration to the Director of the Department of Labor and Industries. The arbitration decision shall be final and conclusive and binding on all parties involved in the dispute as provided for by RCW 39.12.060.
- E. Each Application for Payment submitted by Contractor shall state that prevailing wages have been paid in accordance with the prefled statement(s) of intent, as approved. Copies of the approved intent statement(s) shall be posted on the job site with the address and telephone number of the Industrial Statistician of the Department of Labor and Industries where a complaint or inquiry concerning prevailing wages may be made.
- F. In compliance with chapter 296-127 WAC, Contractor shall pay to the Department of Labor and Industries the currently established fee(s) for each statement of intent and/or affidavit of wages paid submitted to the Department of Labor and Industries for certification.
- G. Copies of approved Intents to Pay Prevailing Wages for the Contractor and all subcontractors shall be submitted with the Contractor's first application for payment. As additional subcontractors perform work on

GENERAL CONDITIONS FOR CONSTRUCTION AT WASHINGTON STATE PARKS

the project, their approved Intent forms shall be submitted with the Contractor's next application for payment.

- H. The Contractor or subcontractor directly contracting for "Off-Site, Prefabricated, Non-Standard, Project Specific Items" shall identify and report information required on the affidavit of wages paid form filed with the Department of Labor and Industries. The Contractor shall include language in its subcontracts requiring subcontractors and lower-tier subcontractors to comply with the reporting requirements for "Off-Site, Prefabricated, Non-Standard, Project Specific Item(s)" on the affidavit of wages paid.

The reporting requirement for Items shall apply for all public works contracts estimated to cost over \$1 million entered into by the Owner and Contractor between September 1, 2010 and December 31, 2013.

"Off-site, prefabricated, nonstandard, project specific item(s)" means products or items that are:

1. Made primarily of architectural or structural precast concrete, fabricated steel, pipe and pipe systems, or sheet metal and sheet metal duct work;
2. Produced specifically for the public work and not considered to be regularly available shelf items;
3. Produced or manufactured by labor expended to assemble or modify standard items; and
4. Produced at an off-site location outside Washington.

The Contractor or subcontractor shall comply with the reporting requirements and instructions on the affidavit of wages paid form, and shall report the following information on the affidavit of wages paid form submitted to the Department of Labor and Industries in order to comply with the reporting requirements for use of "Off-Site, Prefabricated, Non-Standard, Project Specific item(s)":

1. The estimated cost of the public works project;
2. The name of the awarding agency and the project title;
3. The contract value of the off-site, prefabricated, nonstandard, project specific item(s) produced outside of Washington State, including labor and materials; and
4. The name, address, and federal employer identification number of the contractor that produced the off-site, prefabricated, nonstandard, project specific item(s).

The owner may direct the contractor, at no additional cost to the owner, to remove and substitute any subcontractor(s) found to be out of compliance with the "Off-Site Prefabricated Non-Standard Project Specific Item(s)" reporting requirements more than one time as determined by the Department of Labor and Industries.

- I. The Contractor and all subcontractors shall promptly submit to the Owner certified payroll copies if requested.

5.05 HOURS OF LABOR

- A. Contractor shall comply with all applicable provisions of RCW 49.28 and they are incorporated herein by reference. Pursuant to that statute, no laborer, worker, or mechanic employed by Contractor, any Subcontractor, or any other person performing or contracting to do the whole or any part of the Work, shall be permitted or required to work more than eight (8) hours in any one calendar day, provided, that in cases of extraordinary emergency, such as danger to life or property, the hours of work may be extended, but in such cases the rate of pay for time employed in excess of eight (8) hours of each calendar day shall be not less than one and one-half times (x1.5) the rate allowed for this same amount of time during eight (8) hours service.
- B. Notwithstanding the preceding paragraph, RCW 49.28 permits a contractor or subcontractor in any public works contract subject to those provisions, to enter into an agreement with its employees in which the employees work up to ten (10) hours in a calendar day. No such agreement may provide that the employees work ten-hour days for more than four (4) calendar days a week. Any such agreement is subject to approval by the employees. The overtime provisions of RCW 49.28 shall not apply to the hours, up to forty (40) hours per week, worked pursuant to any such agreement.

5.06 NONDISCRIMINATION

- A. Discrimination in all phases of employment is prohibited by, among other laws and regulations, Title VII of the Civil Rights Act of 1964, the Vietnam Era Veterans Readjustment Act of 1974, sections 503 and 504 of the Vocational Rehabilitation Act of 1973, the Equal Employment Act of 1972, the Age Discrimination Act of

GENERAL CONDITIONS FOR CONSTRUCTION AT WASHINGTON STATE PARKS

1967, the Americans with Disabilities Act of 1990, the Civil Rights Act of 1991, Presidential Executive Order 11246, Executive Order 11375, the Washington State Law Against Discrimination, RCW 49.60, and Gubernatorial Executive Order 85-09. These laws and regulations establish minimum requirements for affirmative action and fair employment practices which Contractor must meet.

- B. During performance of the Work:
1. Contractor shall not discriminate against any employee or applicant for employment because of race, creed, color, national origin, sex, age, marital status, or the presence of any physical, sensory, or mental disability, Vietnam era veteran status, or disabled veteran status, nor commit any other unfair practices as defined in RCW 49.60.
 2. Contractor shall, in all solicitations or advertisements for employees placed by or for it, state that the contractor is an "equal opportunity employer".
 3. Contractor shall send to each labor union, employment agency, or representative of workers with which it has a collective bargaining agreement or other contract or understanding, a notice advising the labor union, employment agency, or workers' representative of Contractor's obligations according to the Contract Documents and RCW 49.60.
 4. Contractor shall permit access to its books, records, and accounts, and to its premises by Owner, and by the Washington State Human Rights Commission, for the purpose of investigation to ascertain compliance with this section of the Contract Documents.
 5. Contractor shall include the provisions of this section in every Subcontract.
- C. Nondiscrimination Requirement. During the term of this Contract, Contractor, including any subcontractor, shall not discriminate on the bases enumerated at RCW 49.60.530(3). In addition, Contractor, including any subcontractor, shall give written notice of this nondiscrimination requirement to any labor organizations with which Contractor, or subcontractor, has a collective bargaining or other agreement.
- D. Obligation to Cooperate. Contractor, including any subcontractor, shall cooperate and comply with any Washington state agency investigation regarding any allegation that Contractor, including any subcontractor, has engaged in discrimination prohibited by this Contract pursuant to RCW 49.60.530(3).
- E. Default. Notwithstanding any provision to the contrary, Owner may suspend Contractor, including any subcontractor, upon notice of a failure to participate and cooperate with any state agency investigation into alleged discrimination prohibited by this Contract, pursuant to RCW 49.60.530(3). Any such suspension will remain in place until Owner receives notification that Contractor, including any subcontractor, is cooperating with the investigating state agency. In the event Contractor, or subcontractor, is determined to have engaged in discrimination identified at RCW 49.60.530(3), Owner may terminate this Contract in whole or in part, and Contractor, subcontractor, or both, may be referred for debarment as provided in RCW 39.26.200. Contractor or subcontractor may be given a reasonable time in which to cure this noncompliance, including implementing conditions consistent with any court-ordered injunctive relief or settlement agreement.
- F. Remedies for Breach. Notwithstanding any provision to the contrary, in the event of Contract termination or suspension for engaging in discrimination, Contractor, subcontractor, or both, shall be liable for contract damages as authorized by law including, but not limited to, any cost difference between the original contract and the replacement or cover contract and all administrative costs directly related to the replacement contract, which damages are distinct from any penalties imposed under Chapter 49.60, RCW. Owner shall have the right to deduct from any monies due to Contractor or subcontractor, or that thereafter become due, an amount for damages Contractor or subcontractor will owe Owner for default under this provision.

5.07 SAFETY PRECAUTIONS

- A. In performing this contract, the Contractor shall provide for protecting the lives and health of employees and other persons; preventing damage to property, materials, supplies, and equipment; and avoid work interruptions. For these purposes, the Contractor shall:

GENERAL CONDITIONS FOR CONSTRUCTION AT WASHINGTON STATE PARKS

1. Follow Washington Industrial Safety and Health Act (WISHA) regional directives and provide a site-specific safety program that will require an accident prevention and hazard analysis plan for the contractor and each subcontractor on the work site. The Contractor shall submit a site-specific safety plan to the Owner's representative prior to the initial scheduled construction meeting.
 2. Provide adequate safety devices and measures including, but not limited to, the appropriate safety literature, notice, training, permits, placement and use of barricades, signs, signal lights, ladders, scaffolding, staging, runways, hoist, construction elevators, shoring, temporary lighting, grounded outlets, wiring, hazardous materials, vehicles, construction processes, and equipment required by Chapter 19.27 RCW, State Building Code (International Building, Electrical, Mechanical, Fire, and Uniform Plumbing Codes); Chapter 212-12 WAC, Fire Marshal Standards, Chapter 49.17 RCW, WISHA; Chapter 296-155 WAC, Safety Standards for Construction Work; Chapter 296-65 WAC; WISHA Asbestos Standard; WAC 296-62-071, Respirator Standard; WAC 296-62, General Occupation Health Standards, WAC 296-24, General Safety and Health Standards, WAC 296-24, General Safety and Health Standards, Chapter 49.70 RCW, and Right to Know Act.
 3. Comply with the State Environmental Policy Act (SEPA), Clean Air Act, Shoreline Management Act, and other applicable federal, state, and local statutes and regulations dealing with the prevention of environmental pollution and the preservation of public natural resources.
 4. Post all permits, notices, and/or approvals in a conspicuous location at the construction site.
 5. Provide any additional measures that the Owner determines to be reasonable and necessary for ensuring a safe environment in areas open to the public. Nothing in this part shall be construed as imposing a duty upon the Owner or A/E to prescribe safety conditions relating to employees, public, or agents of the Contractors.
 6. The Contractor shall make available a list of hazardous products being used on the project, and their respective Material Safety Data Sheets (MSDS) to the Engineer. This information will be required at the pre-construction conference.
- B. In carrying out its responsibilities according to the Contract Documents, Contractor shall protect the lives and health of employees performing the Work and other persons who may be affected by the Work; prevent damage to materials, supplies, and equipment whether on site or stored off-site; and prevent damage to other property at the site or adjacent thereto. Contractor shall comply with all applicable laws, ordinances, rules, regulations, and orders of any public body having jurisdiction for the safety of persons or property or to protect them from damage, injury, or loss; shall erect and maintain all necessary safeguards for such safety and protection; and shall notify owners of adjacent property and utilities when prosecution of the Work may affect them.
- C. Contractor shall maintain an accurate record of exposure data on all incidents relating to the Work resulting in death, traumatic injury, occupational disease, or damage to property, materials, supplies, or equipment. Contractor shall immediately report any such incident to Owner. Owner shall, at all times, have a right of access to all records of exposure.
- D. Contractor shall provide all persons working on the Project site with information and training on hazardous chemicals in their work at the time of their initial assignment, and whenever a new hazard is introduced into their work area.
1. Information. At a minimum, Contractor shall inform persons working on the Project site of:
 - a. The requirements of chapter 296-62 WAC, General Occupational Health Standards;
 - b. Any operations in their work area where hazardous chemicals are present; and
 - c. The location and availability of written hazard communication programs, including the required list(s) of hazardous chemicals and material safety data sheets required by chapter 296-62 WAC.
 2. Training. At a minimum, Contractor shall provide training for persons working on the Project site which includes:

GENERAL CONDITIONS FOR CONSTRUCTION AT WASHINGTON STATE PARKS

- a. Methods and observations that may be used to detect the presence or release of a hazardous chemical in the work area (such as monitoring conducted by the employer, continuous monitoring devices, visual appearance or odor of hazardous chemicals when being released, etc.);
 - b. The physical and health hazards of the chemicals in the work area;
 - c. The measures such persons can take to protect themselves from these hazards, including specific procedures Contractor, or its Subcontractors, or others have implemented to protect those on the Project site from exposure to hazardous chemicals, such as appropriate work practices, emergency procedures, and personal protective equipment to be used; and
 - d. The details of the hazard communications program developed by Contractor, or its Subcontractors, including an explanation of the labeling system and the material safety data sheet, and how employees can obtain and use the appropriate hazard information.
- E. Contractor's responsibility for hazardous, toxic, or harmful substances shall include the following duties:
1. Contractor shall not keep, use, dispose, transport, generate, or sell on or about the Project site, any substances now or hereafter designated as, or which are subject to regulation as, hazardous, toxic, dangerous, or harmful by any federal, state or local law, regulation, statute or ordinance (hereinafter collectively referred to as "hazardous substances", in violation of any such law, regulation, statute, or ordinance, but in no case shall any such hazardous substance be stored more than 90 days on the Project site.
 2. Contractor shall promptly notify Owner of all spills or releases of any hazardous substances which are otherwise required to be reported to any regulatory agency and pay the cost of cleanup. Contractor shall promptly notify Owner of all failures to comply with any federal, state, or local law, regulation, or ordinance; all inspections of the Project site by any regulatory entity concerning the same; all regulatory orders or fines; and all responses or interim cleanup actions taken by or proposed to be taken by any government entity or private party on the Project site.
- F. All Work shall be performed with due regard for the safety of the public. Contractor shall perform the Work so as to cause a minimum of interruption of vehicular traffic or inconvenience to pedestrians. All arrangements to care for such traffic shall be Contractor's responsibilities. All expenses involved in the maintenance of traffic by way of detours shall be borne by Contractor.
- G. In an emergency affecting the safety of life or the Work or of adjoining property, Contractor is permitted to act, at its discretion, to prevent such threatened loss or injury, and Contractor shall so act if so authorized or instructed.
- H. Nothing provided in this section shall be construed as imposing any duty upon Owner or A/E with regard to, or as constituting any express or implied assumption of control or responsibility over, Project site safety, or over any other safety conditions relating to employees or agents of Contractor or any of its Subcontractors, or the public.

5.08 OPERATIONS, MATERIAL HANDLING, AND STORAGE AREAS

- A. Contractor shall confine all operations, including storage of materials, to Owner-approved areas.
- B. Temporary buildings (e.g., storage sheds, shops, offices) and utilities may be provided by Contractor only with the consent of Owner and without expense to Owner. The temporary buildings and utilities shall remain the property of Contractor and shall be removed by Contractor at its expense upon completion of the Work.
- C. Contractor shall use only established roadways or temporary roadways authorized by Owner. When materials are transported in prosecuting the Work, vehicles shall not be loaded beyond the loading capacity recommended by the manufacturer of the vehicle or prescribed by federal, state, or local law or regulation.
- D. Ownership and control of all materials or facility components to be demolished or removed from the Project site by Contractor shall immediately vest in Contractor upon severance of the component from the facility or severance of the material from the Project site. Contractor shall be responsible for compliance with all

GENERAL CONDITIONS FOR CONSTRUCTION AT WASHINGTON STATE PARKS

laws governing the storage and ultimate disposal. Contractor shall provide Owner with a copy of all manifests and receipts evidencing proper disposal when required by Owner or applicable law.

- E. Contractor shall be responsible for the proper care and protection of its materials and equipment delivered to the Project site. Materials and equipment may be stored on the premises subject to approval of Owner. When Contractor uses any portion of the Project site as a shop, Contractor shall be responsible for any repairs, patching, or cleaning arising from such use.
- F. Contractor shall protect and be responsible for any damage or loss to the Work, or to the materials or equipment until the date of Substantial Completion, and shall repair or replace without cost to Owner any damage or loss that may occur, except damages or loss caused by the acts or omissions of Owner. Contractor shall also protect and be responsible for any damage or loss to the Work, or to the materials or equipment, after the date of Substantial Completion, and shall repair or replace without cost to Owner any such damage or loss that might occur, to the extent such damages or loss are caused by the acts or omissions of Contractor, or any Subcontractor.
- G. Any removed item shall be salvaged without undue damage and stockpiled in a neat and orderly fashion in an area designated by the Engineer. All removed items shall remain the property of the Owner, unless, due to their condition, they are rejected by the Engineer. All materials of whatever nature that are rejected shall be properly disposed by the Contractor in compliance with all laws and regulations.
- H. If designated campsites or emergency overflow areas are approved for use, the Contractor shall comply with all campground rules and regulations of the Washington State Parks and Recreation Commission and the park manager.

5.09 PRIOR NOTICE OF EXCAVATION

- A. "Excavation" means an operation in which earth, rock, or other material on or below the ground is moved or otherwise displaced by any means, except the tilling of soil less than 12 (twelve) inches in depth for agricultural purposes, or road ditch maintenance that does not change the original road grade or ditch flow line. Before commencing any excavation, Contractor shall provide notice of the scheduled commencement of excavation to all owners of underground facilities or utilities, through locator services.

5.10 UNFORESEEN PHYSICAL CONDITIONS

- A. If Contractor encounters conditions at the site which are subsurface or otherwise concealed physical conditions which differ materially from those indicated in the Contract Documents, or unknown physical conditions of an unusual nature which differ materially from those ordinarily found to exist and generally recognized as inherent in construction activities of the character provided for in the Contract Documents, then Contractor shall give written notice to Owner promptly and in no event later than 7 (seven) days after the first observance of the conditions. Conditions shall not be disturbed prior to such notice.
- B. If such conditions differ materially and cause a change in Contractor's cost of, or time required for, performance of any part of the Work, the Contractor may be entitled to an equitable adjustment in the Contract Time or Contract Sum, or both, provided it makes a request therefore as provided in part 7.

5.11 PROTECTION OF EXISTING STRUCTURES, EQUIPMENT, VEGETATION, UTILITIES, AND IMPROVEMENTS

- A. Contractor shall protect from damage all existing structures, equipment, improvements, utilities, and vegetation: at or near the Project site; and on adjacent property of a third party, the locations of which are made known to or should be known by Contractor. Contractor shall repair any damage, including that to the property of a third party, resulting from failure to comply with the requirements of the Contract Documents or failure to exercise reasonable care in performing the Work. If Contractor fails or refuses to repair the damage promptly, Owner may have the necessary work performed and charge the cost to Contractor.
- B. Contractor shall only remove trees when specifically authorized to do so, and shall protect vegetation that will remain in place.
- C. In general, the locations of existing major utilities and equipment, whether above ground or underground, are indicated on the drawings. This information has been obtained from utility maps and verbal

GENERAL CONDITIONS FOR CONSTRUCTION AT WASHINGTON STATE PARKS

descriptions. The Engineer does not guarantee the accuracy or completeness of this information. Other above ground or underground facilities not shown on the drawings may be encountered during the course of the work for which the Contractor is fully responsible to properly locate and identify within the construction area.

- D. Existing above ground and underground facilities and appurtenant structures, which includes but is not limited to, power transmission and distribution, telephone, alarm systems, sanitary sewers, gas services, water service and house or yard drains and fences, shall be located, protected, maintained, relocated, rerouted, removed and restored as may be necessary by the Contractor for completion of the work, but in a manner satisfactory to their respective owners and operators of the services and to the Engineer with the least possible interruption to existing services.
- E. The Contractor shall be responsible for location and maintenance of existing utilities and improvements. Under no circumstances will errors or omissions in location of utilities or improvements, whether they be visible from the surface, buried, or otherwise obscured, be considered as a basis for a claim for additional compensation by the Contractor.
- F. All utilities shall be protected and maintained in continuous operation except where special arrangements have been made with the appropriate utility owner. All damaged utilities shall be restored to original condition, subject to the approval of its owner and at the Contractor's own expense.
- G. If requested, the Contractor shall provide record information about locations, depths, and dimensions of lines, appurtenances, and structures, and any other relevant information about electrical power, water, sewer, and other utilities.
- H. The Contractor shall provide the Engineer with the data required to make a detailed set of record plans. This data will be obtained and recorded by the Contractor during construction on plans supplied by the Engineer. The Contractor shall ensure that the data is obtained. Typical information to be gathered includes the locations of:
 - 1. Buried utilities
 - 2. Junctions of sewer wyes
 - 3. Junctions of electrical taps
 - 4. Clean-outs
 - 5. Deflection points of utilities
 - 6. Valves
- I. Procedure for obtaining this information will be developed by the Engineer working with the Contractor.
- J. Contractor shall protect all existing facilities using whatever methods are necessary, subject to the Engineer's approval. Trees, shrubs, vegetation, or lawn shall not be damaged, scarred, or destroyed unless deemed necessary for work on this contract. All trees damaged during construction shall be immediately repaired using SEAL AND HEAL or other materials as directed by the Engineer. Any damage to the above-mentioned items shall be repaired at the Contractor's expense and to the Engineer's satisfaction.
- K. In the event that archaeological resources are found or unearthed on public land during the performance of this contract, the Contractor shall be required to comply with RCW 27.44 and RCW 27.53 and the rules and regulations of the office of Archaeology and Historic Preservation, including compliance with all archaeological excavation permit requirements.

5.12 LAYOUT OF WORK

- A. Contractor shall plan and lay out the Work in advance of operations so as to coordinate all work without delay or revision.
- B. Contractor shall lay out the Work from Owner-established baselines and bench marks indicated on the Drawings, and shall be responsible for all field measurements in connection with the layout. Contractor shall furnish, at its own expense, all stakes, templates, platforms, equipment, tools, materials, and labor required to lay out any part of the Work. Contractor shall be responsible for executing the Work to the lines

GENERAL CONDITIONS FOR CONSTRUCTION AT WASHINGTON STATE PARKS

and grades that may be established. Contractor shall be responsible for maintaining or restoring all stakes and other marks established.

- C. The indicated limits of work shall be the controlling factor in the Contractor's scope of operation and no payment shall be due for work done out of the limits. Damage to areas not in the Contractor's work area shall be repaired at the Contractor's expense. Questions of what constitutes the work area shall be determined by the Engineer. Only the best methods of construction will be allowed.
- D. The Engineer may adjust or relocate any portion of the system to meet site requirements or to improve the system without additional compensation to the Contractor, provided such adjustments do not represent appreciable costs for additional labor and materials.

5.13 MATERIAL AND EQUIPMENT

- A. All equipment, material, and articles incorporated into the Work shall be new and of the most suitable grade for the purpose intended, unless otherwise specifically provided in the Contract Documents. References in the Specifications to equipment, material, articles, or patented processes by trade name, make, or catalog number, shall be regarded as establishing a standard quality and shall not be construed as limiting competition. Contractor may, at its option, use any equipment, material, article, or process that, in the judgment of A/E, is equal to that named in the specifications, unless otherwise specifically provided in the Contract Documents.
- B. Contractor shall do all cutting, fitting, or patching that may be required to make its several parts fit together properly, or receive or be received by work of others set forth in, or reasonably implied by, the Contract Documents. Contractor shall not endanger any work by cutting, excavating, or otherwise altering the Work and shall not cut or alter the work of any other contractor unless approved in advance by Owner.
- C. Should any of the Work be found defective, or in any way not in accordance with the Contract Documents, this work, in whatever stage of completion, may be rejected by Owner.
- D. The Contractor shall furnish proof of equality in all respects to the specified items when proposing alternate brands or materials. Any significant deviations from specifications, drawings, or equality must be noted by the Contractor when submitting alternate products or materials for approval. The Engineer shall be the sole judge of the equality and suitability of any products, materials, or components proposed by the Contractor as alternates to specified items. The Contractor shall bear all costs and make all secondary changes required to incorporate an approved substitute or alternate into the work. No offers for substitution will be acknowledged from suppliers, distributors, manufacturers, or subcontractors.

5.14 AVAILABILITY AND USE OF UTILITY SERVICES

- A. Owner shall make all reasonable utilities available to Contractor from existing outlets and supplies, as specified in the Contract Documents. Unless otherwise provided in the Contract Documents, the utility service consumed shall be charged to or paid for by Contractor at prevailing rates charged to Owner or, where the utility is produced by Owner, at reasonable rates determined by Owner. Contractor will carefully conserve any utilities furnished.
- B. Contractor shall, at its expense and in a skillful manner satisfactory to Owner, install and maintain all necessary temporary connections and distribution lines, together with appropriate protective devices, and all meters required to measure the amount of each utility used for the purpose of determining charges. Prior to the date of Final Acceptance, Contractor shall remove all temporary connections, distribution lines, meters, and associated equipment and materials.

5.15 TESTS AND INSPECTION

- A. Contractor shall maintain an adequate testing and inspection program and perform such tests and inspections as are necessary or required to ensure that the Work conforms to the requirements of the Contract Documents. Contractor shall be responsible for inspection and quality surveillance of all its Work and all Work performed by any Subcontractor. Unless otherwise provided, Contractor shall make arrangements for such tests, inspections, and approvals with an independent testing laboratory or entity acceptable to Owner, or with the appropriate public authority, and shall bear all related costs of tests, inspections, and approvals. Contractor shall give Owner timely notice of when and where tests and

GENERAL CONDITIONS FOR CONSTRUCTION AT WASHINGTON STATE PARKS

inspections are to be made. Contractor shall maintain complete inspection records and make them available to Owner.

- B. Owner may, at any reasonable time, conduct such inspections and tests as it deems necessary to ensure that the Work is in accordance with the Contract Documents. Owner shall promptly notify Contractor if an inspection or test reveals that the Work is not in accordance with the Contract Documents. Unless the subject items are expressly accepted by Owner, such Owner inspection and tests are for the sole benefit of Owner and do not:
 - 1. Constitute or imply acceptance;
 - 2. Relieve Contractor of responsibility for providing adequate quality control measures;
 - 3. Relieve Contractor of responsibility for risk of loss or damage to the Work, materials, or equipment;
 - 4. Relieve Contractor of its responsibility to comply with the requirements of the Contract Documents; or
 - 5. Impair Owner's right to reject defective or nonconforming items, or to avail itself of any other remedy to which it may be entitled.
- C. Neither observations by an inspector retained by Owner, the presence or absence of such inspector on the site, nor inspections, tests, or approvals by others, shall relieve Contractor from any requirement of the Contract Documents, nor is any such inspector authorized to change any term or condition of the Contract Documents.
- D. Contractor shall promptly furnish, without additional charge, all facilities, labor, material and equipment reasonably needed for performing such safe and convenient inspections and tests as may be required by Owner. Owner may charge Contractor any additional cost of inspection or testing when Work is not ready at the time specified by Contractor for inspection or testing, or when prior rejection makes re-inspection or retest necessary. Owner shall perform its inspections and tests in a manner that will cause no undue delay in the Work.
- E. The Owner shall have the right to appoint an Inspector who will have the authority to reject materials or workmanship which does not fulfill the requirements of these specifications. In case of dispute, the Contractor may appeal to the Engineer whose decision shall be final. The acceptance of any material by the Inspector shall not hinder its subsequent rejection if found defective. Rejected materials and workmanship shall be replaced promptly or be made good by the Contractor without additional cost to the Owner.
- F. Contractor shall deliver one (1) key for each type of lock installed on the project to the Engineer to enable the Engineer to enter all facilities under construction for the purpose of inspection. This includes temporary as well as State Parks' key-coded locks. All keys for key-coded locks shall be delivered to the Engineer as they are made available to the Contractor. These coded keys shall then be signed out to the Contractor on an accountable basis for security purposes.

5.16 CORRECTION OF NONCONFORMING WORK

- A. If a portion of the Work is covered contrary to the requirements in the Contract Documents, it must, if required in writing by Owner, be uncovered for Owner's observation and be replaced at the Contractor's expense and without change in the Contract Time.
- B. If, at any time prior to Final Completion, Owner desires to examine the Work, or any portion of it, which has been covered, Owner may request to see such Work and it shall be uncovered by Contractor. If such Work is in accordance with the Contract Documents, the Contractor shall be entitled to an adjustment in the Contract Sum for the costs of uncovering and replacement, and, if completion of the Work is thereby delayed, an adjustment in the Contract Time, provided it makes a request therefore as provided in part 7. If such Work is not in accordance with the Contract Documents, the Contractor shall pay the costs of examination and reconstruction.
- C. Contractor shall promptly correct Work found by Owner not to conform to the requirements of the Contract Documents, whether observed before or after Substantial Completion and whether or not fabricated, installed, or completed. Contractor shall bear all costs of correcting such nonconforming Work, including additional testing and inspections.

GENERAL CONDITIONS FOR CONSTRUCTION AT WASHINGTON STATE PARKS

- D. If, within one year after the date of Substantial Completion of the Work or designated portion thereof, or within one year after the date for commencement of any system warranties established under section 6.08, or within the terms of any applicable special warranty required by the Contract Documents, any of the Work is found to be not in accordance with the requirements of the Contract Documents, Contractor shall correct it promptly after receipt of written notice from Owner to do so. Owner shall give such notice promptly after discovery of the condition. This period of one year shall be extended, with respect to portions of Work first performed after Substantial Completion, by the period of time between Substantial Completion and the actual performance of the Work. Contractor's duty to correct with respect to Work repaired or replaced shall run for one year from the date of repair or replacement. Obligations under this paragraph shall survive Final Acceptance.
- E. Contractor shall remove from the Project site portions of the Work which are not in accordance with the requirements of the Contract Documents and are neither corrected by Contractor nor accepted by Owner.
- F. If Contractor fails to correct nonconforming Work within a reasonable time after written notice to do so, Owner may replace, correct, or remove the nonconforming Work and charge the cost thereof to the Contractor.
- G. Contractor shall bear the cost of correcting destroyed or damaged Work, whether completed or partially completed, caused by Contractor's correction or removal of Work which is not in accordance with the requirements of the Contract Documents.
- H. Nothing contained in this section shall be construed to establish a period of limitation with respect to other obligations which Contractor might have according to the Contract Documents. Establishment of the time period of one (1) year as described in paragraph 5.16D relates only to the specific obligation of Contractor to correct the Work, and has no relationship to the time within which the Contractor's obligation to comply with the Contract Documents may be sought to be enforced, including the time within which such proceedings may be commenced.
- I. If Owner prefers to accept Work which is not in accordance with the requirements of the Contract Documents, Owner may do so instead of requiring its removal and correction, in which case the Contract Sum may be reduced as appropriate and equitable.

5.17 CLEAN UP

Contractor shall at all times keep the Project site, including hauling routes, infrastructures, utilities, and storage areas, free from accumulations of waste materials. Before completing the Work, Contractor shall remove from the premises its rubbish, tools, scaffolding, equipment, and materials. Upon completing the Work, Contractor shall leave the Project site in a clean, neat, and orderly condition satisfactory to Owner. If Contractor fails to clean up as provided herein, and after reasonable notice from Owner, Owner may do so and the cost thereof shall be charged to Contractor.

5.18 ACCESS TO WORK

Contractor shall provide Owner and A/E access to the Work in progress wherever located.

5.19 OTHER CONTRACTS

Owner may undertake or award other contracts for additional work at or near the Project site. Contractor shall reasonably cooperate with the other contractors and with Owner's employees and shall carefully adapt scheduling and perform the Work in accordance with these Contract Documents to reasonably accommodate the other work.

5.20 SUBCONTRACTORS AND SUPPLIERS

- A. The Contractor shall include the language of this paragraph in each of its first tier subcontracts, and shall require each of its subcontractors to include the same language of this section in each of their subcontracts, adjusting only as necessary the terms used for the contracting parties. Upon request of the Owner, the Contractor shall promptly provide documentation to the Owner demonstrating that the subcontractor meets the subcontractor responsibility criteria below. The requirements of this paragraph apply to all subcontractors regardless of tier. At the time of subcontract execution, the Contractor shall verify that each of its first tier subcontractors meets the following bidder responsibility criteria:

GENERAL CONDITIONS FOR CONSTRUCTION AT WASHINGTON STATE PARKS

1. Have a current certificate of registration as a contractor in compliance with chapter 18.27 RCW, which must have been in effect at the time of subcontract bid submittal;
 2. Have a current Washington Unified Business Identifier (UBI) number;
 3. If applicable, have:
 - a. Industrial Insurance (workers' compensation) coverage for the subcontractor's employees working in Washington, as required in Title 51 RCW;
 - b. A Washington Employment Security Department number, as required in Title 50 RCW;
 - c. A Washington Department of Revenue state excise tax registration number, as required in Title 82 RCW;
 - d. An electrical contractor license, if required by Chapter 19.28 RCW;
 - e. An elevator contractor license, if required by Chapter 70.87 RCW.
 4. Not be disqualified from bidding on any public works contract under RCW 39.06.010 or 39.12.065 (3).
 5. On a project subject to the apprenticeship utilization requirements in RCW 39.04.320, not have been found out of compliance by the Washington state apprenticeship and training council for working apprentices out of ratio, without appropriate supervision, or outside their approved work processes as outlined in their standards of apprenticeship under chapter 49.04 RCW for the one-year period immediately preceding the date of the Owner's first advertisement of the project.
- B. Prior to submitting the first Application for Payment, Contractor shall furnish in writing to Owner, on Owner provided form(s), the names, addresses, telephone numbers, and Tax Identification Numbers (TIN) of all subcontractors, as well as suppliers providing materials in excess of \$2,500.00 which Contractor believes to be MBE or WBE owned businesses, or have identified themselves to the Contractor as MBE or WBE, or are Washington State OMWBE certified. The Contractor shall indicate the anticipated dollar value of each MWBE subcontract. Contractor shall utilize subcontractors and suppliers, which are experienced and qualified, and meet the requirements of the Contract Documents, if any. Contractor shall not utilize any subcontractor or supplier to whom the Owner has a reasonable objection, and shall obtain Owner's written consent before making any substitutions or additions. The Owner may direct the Contractor, at no additional cost to the Owner, to remove and substitute any subcontractor(s) found to be out of compliance with the "Off-Site Prefabricated Non-Standard Project Specific Items" reporting requirements more than one time as determined by the Department of Labor and Industries and as defined in EHB 2805 that amends RCW 39.04.
- C. All Subcontracts must be in writing. By appropriate written agreement, Contractor shall require each Subcontractor, so far as applicable to the Work to be performed by the Subcontractor, to be bound to Contractor by terms of the Contract Documents, and to assume toward Contractor all the obligations and responsibilities which Contractor assumes toward Owner in accordance with the Contract Documents. Each Subcontract shall preserve and protect the rights of Owner in accordance with the Contract Documents with respect to the Work to be performed by the Subcontractor so that subcontracting thereof will not prejudice such rights. Where appropriate, Contractor shall require each Subcontractor to enter into similar agreements with Sub-subcontractors. However, nothing in this paragraph shall be construed to alter the contractual relations between Contractor and its Subcontractors with respect to insurance or bonds.
- D. Contractor shall schedule, supervise, and coordinate the operations of all Subcontractors. No Subcontracting of any of the Work shall relieve Contractor from its responsibility for the performance of the Work in accordance with the Contract Documents or any other obligations of the Contract Documents.
- E. Each subcontract agreement for a portion of the Work is hereby assigned by Contractor to Owner provided that:
1. The assignment is effective only after termination by Owner for cause pursuant to section 9.01 and only for those Subcontracts which Owner accepts by notifying the Subcontractor in writing; and
 2. After the assignment is effective, Owner will assume all future duties and obligations toward the Subcontractor which Contractor assumed in the Subcontract.
 3. The assignment is subject to the prior rights of the surety, if any, obligated under any bond provided in accordance with the Contract Documents.

GENERAL CONDITIONS FOR CONSTRUCTION AT WASHINGTON STATE PARKS

5.21 WARRANTY OF CONSTRUCTION

- A. In addition to any special warranties provided elsewhere in the Contract Documents, Contractor warrants that all Work conforms to the requirements of the Contract Documents and is free of any defect in equipment, material, or design furnished, or workmanship performed, by Contractor.
- B. With respect to all warranties, express or implied, for Work performed or materials furnished according to the Contract Documents, Contractor shall:
 - 1. Obtain all warranties that would be given in normal commercial practice;
 - 2. Require all warranties to be executed, in writing, for the benefit of Owner;
 - 3. Enforce all warranties for the benefit of Owner, if directed by Owner; and
 - 4. Be responsible to enforce any subcontractor's, manufacturer's, or supplier's warranty should they extend beyond the period specified in the Contract Documents.
- C. The obligations under this section shall survive Final Acceptance.

5.22 INDEMNIFICATION

- A. Contractor shall defend, indemnify, and hold Owner and A/E harmless from and against all claims, demands, losses, damages, or costs, including but not limited to damages arising out of bodily injury or death to persons and damage to property, caused by or resulting from:
 - 1. The sole negligence of Contractor or any of its Subcontractors;
 - 2. The concurrent negligence of Contractor, or any Subcontractor, but only to the extent of the negligence of Contractor or such Subcontractor; and
 - 3. The use of any design, process, or equipment which constitutes an infringement of any United States patent presently issued, or violates any other proprietary interest, including copyright, trademark, and trade secret.
- B. In any action against Owner and any other entity indemnified in accordance with this section, by any employee of Contractor, its Subcontractors, Sub-subcontractors, agents, or anyone directly or indirectly employed by any of them, the indemnification obligation of this section shall not be limited by a limit on the amount or type of damages, compensation, or benefits payable by or for Contractor or any Subcontractor under RCW Title 51, the Industrial Insurance Act, or any other employee benefit acts. In addition, Contractor waives immunity as to Owner and A/E only, in accordance with RCW Title 51.

PART 6 - PAYMENTS AND COMPLETION

6.01 CONTRACT SUM

Owner shall pay Contractor the Contract Sum for performance of the Work, in accordance with the Contract Documents. The Contract Sum shall include all taxes imposed by law and properly chargeable to the Project, including sales tax.

6.02 SCHEDULE OF VALUES

Before submitting its first Application for Payment, Contractor shall submit to Owner for approval a breakdown allocating the total Contract Sum to each principle category of work, in such detail as requested by Owner ("Schedule of Values"). The approved Schedule of Values shall include appropriate amounts for demobilization, record drawings, O&M manuals, and any other requirements for Project closeout, and shall be used by Owner as the basis for progress payments. Payment for Work shall be made only for and in accordance with those items included in the Schedule of Values.

6.03 APPLICATION FOR PAYMENT

GENERAL CONDITIONS FOR CONSTRUCTION AT WASHINGTON STATE PARKS

- A. At monthly intervals, unless determined otherwise by Owner, Contractor shall submit to Owner an itemized Application for Payment for Work completed in accordance with the Contract Documents and the approved Schedule of Values. Each application shall be supported by such substantiating data as Owner may require.
- B. By submitting an Application for Payment, Contractor is certifying that all Subcontractors have been paid, less earned retainage in accordance with RCW 60.28.010, as their interests appeared in the last preceding certificate of payment. By submitting an Application for Payment, Contractor is recertifying that the representations set forth in section 1.03 are true and correct, to the best of Contractor's knowledge, as of the date of the Application for Payment.
- C. At the time it submits an Application for Payment, Contractor shall analyze and reconcile, to the satisfaction of Owner, the actual progress of the Work with the Progress Schedule.
- D. If authorized by Owner, the Application for Payment may include request for payment for material delivered to the Project site and suitably stored, or for completed preparatory work. Payment may similarly be requested for material stored off the Project site, provided Contractor complies with or furnishes satisfactory evidence of the following:
 - 1. The material will be placed in a warehouse that is structurally sound, dry, lighted, and suitable for the materials to be stored;
 - 2. The warehouse is located within a 10-mile radius of the Project. Other locations may be utilized, if approved in writing, by Owner;
 - 3. Only materials for the Project are stored within the warehouse (or a secure portion of a warehouse set aside for the Project);
 - 4. Contractor furnishes Owner a certificate of insurance extending Contractor's insurance coverage for damage, fire, and theft to cover the full value of all materials stored, or in transit;
 - 5. The warehouse (or secure portion thereof) is continuously under lock and key, and only Contractor's authorized personnel shall have access;
 - 6. Owner shall at all times have the right of access in company of Contractor;
 - 7. Contractor and its surety assume total responsibility for the stored materials; and
 - 8. Contractor furnishes to Owner certified lists of materials stored, bills of lading, invoices, and other information as may be required, and shall also furnish notice to Owner when materials are moved from storage to the Project site.

6.04 PROGRESS PAYMENTS

- A. Owner shall make progress payments, in such amounts as Owner determines are properly due, within 30 days after receipt of a properly executed Application for Payment. Owner shall notify Contractor in accordance with RCW 39.76 if the Application for Payment does not comply with the requirements of the Contract Documents.
- B. Owner shall retain 5% (five percent) of the amount of each progress payment until forty-five (45) days after Final Acceptance and receipt of all documents required by law or the Contract Documents, including, at Owner's request, consent of surety to release of the retainage. In accordance with RCW 60.28, Contractor may request that monies reserved be retained in a fund by Owner, deposited by Owner in a bank or savings and loan, or placed in escrow with a bank or trust company to be converted into bonds and securities to be held in escrow with interest to be paid to Contractor. Owner may permit Contractor to provide an appropriate bond in lieu of the retained funds.
- C. Title to all Work and materials covered by a progress payment shall pass to Owner at the time of such payment free and clear of all liens, claims, security interests, and encumbrances. Passage of title shall not, however, relieve Contractor from any of its duties and responsibilities for the Work or materials, or waive any rights of Owner to insist on full compliance by Contractor with the Contract Documents.

GENERAL CONDITIONS FOR CONSTRUCTION AT WASHINGTON STATE PARKS

- D. Payments due and unpaid in accordance with the Contract Documents shall bear interest as specified in RCW 39.76.

6.05 PAYMENTS WITHHELD

- A. Owner may withhold or, on account of subsequently discovered evidence, nullify the whole or part of any payment to such extent as may be necessary to protect Owner from loss or damage for reasons including but not limited to:
1. Work not in accordance with the Contract Documents;
 2. Reasonable evidence that the Work required by the Contract Documents cannot be completed for the unpaid balance of the Contract Sum;
 3. Work by Owner to correct defective Work or complete the Work in accordance with section 5.17;
 4. Failure to perform in accordance with the Contract Documents; or
 5. Cost or liability that may occur to Owner as the result of Contractor's fault or negligent acts or omissions.
- B. In any case where part or all of a payment is going to be withheld for unsatisfactory performance, Owner shall notify Contractor in accordance with RCW 39.76.

6.06 RETAINAGE AND BOND CLAIM RIGHTS

- A. Prior to release of the contract retainage, an "Affidavit of Wages Paid", approved by the Washington State Department of Labor and Industries, must be on file in the Owner's office. Contracts over \$20,000, including tax, necessitate a clearance from the Washington State Department of Revenue and the Washington State Department of Employment Security. The Owner shall initiate action for the releases from the Departments of Revenue and Employment Security.
- B. RCW chapters 39.08 and 60.28, concerning the rights and responsibilities of Contractor and Owner with regard to the performance and payment bonds and retainage, are made a part of the Contract Documents by reference as though fully set forth herein.
- C. In accordance with RCW 60.28, the lien period for filing liens against the contract retainage shall be forty-five (45) days. Persons performing labor or furnishing supplies toward the completion of the contract who intend to file a lien against the contract retainage must do so within forty-five (45) days from the date of Final Acceptance of the contract by the Owner and in the manner as described in RCW 39.08.030.

6.07 SUBSTANTIAL COMPLETION

Substantial Completion is the stage in the progress of the Work (or portion thereof designated and approved by Owner) when the construction is sufficiently complete, in accordance with the Contract Documents, so Owner can fully occupy the Work (or the designated portion thereof) for the use for which it is intended. All Work other than incidental corrective or punch list work shall be completed. Substantial Completion shall not have been achieved if all systems and parts are not functional, if utilities are not connected and operating normally, if all required occupancy permits have not been issued, or if the Work is not accessible by normal vehicular and pedestrian traffic routes. The date Substantial Completion is achieved shall be established in writing by Owner. Contractor may request an early date of Substantial Completion which must be approved by Change Order. Owner's occupancy of the Work or designated portion thereof does not necessarily indicate that Substantial Completion has been achieved.

6.08 PRIOR OCCUPANCY

- A. Owner may, upon written notice thereof to Contractor, take possession of or use any completed or partially completed portion of the Work ("Prior Occupancy") at any time prior to Substantial Completion. Unless otherwise agreed in writing, Prior Occupancy shall not: be deemed an acceptance of any portion of the Work; accelerate the time for any payment to Contractor; prejudice any rights of Owner provided by any insurance, bond, guaranty, or the Contract Documents; relieve Contractor of the risk of loss or any of the

GENERAL CONDITIONS FOR CONSTRUCTION AT WASHINGTON STATE PARKS

obligations established by the Contract Documents; establish a date for termination or partial termination of the assessment of liquidated damages; or constitute a waiver of claims.

- B. Notwithstanding anything in the preceding paragraph, Owner shall be responsible for loss of or damage to the Work resulting from Prior Occupancy. Contractor's one (1) year duty to repair and any system warranties shall begin on building systems activated and used by Owner as agreed in writing by Owner and Contractor.

6.09 FINAL COMPLETION, ACCEPTANCE, AND PAYMENT

- A. Final Completion shall be achieved when the Work is fully and finally complete in accordance with the Contract Documents. The date Final Completion is achieved shall be established by Owner in writing.
- B. Final Acceptance is the formal action of Owner acknowledging Final Completion. Prior to Final Acceptance, Contractor shall, in addition to all other requirements in the Contract Documents, submit to Owner a written notice of any outstanding disputes or claims between Contractor and any of its Subcontractors, including the amounts and other details thereof. Neither Final Acceptance, nor final payment, shall release Contractor or its sureties from any obligations of these Contract Documents or the Public Works Bond, or constitute a waiver of any claims by Owner arising from Contractor's failure to perform the Work in accordance with the Contract Documents.
- C. Acceptance of final payment by Contractor, or any Subcontractor, shall constitute a waiver and release to Owner of all claims by Contractor, or any such Subcontractor, for an increase in the Contract Sum or the Contract Time, and for every act or omission of Owner relating to or arising out of the Work, except for those Claims made in accordance with the procedures, including the time limits, set forth in part 8.

PART 7 - CHANGES

7.01 CHANGES IN THE WORK

- A. Owner may, at any time and without notice to Contractor's surety, order additions, deletions, revisions, or other changes in the Work. These changes in the Work shall be incorporated into the Contract Documents through the execution of Change Orders. If any change in the Work ordered by Owner causes an increase or decrease in the Contract Sum or the Contract Time, an equitable adjustment shall be made as provided in section 7.02 or 7.03, respectively, and such adjustment(s) shall be incorporated into a Change Order.
- B. If Owner desires to order a change in the Work, it may request a written Change Order Proposal (COP) from Contractor. Contractor shall submit a Change Order Proposal within 14 (fourteen) days of the request from Owner, or within such other period as mutually agreed. Contractor's Change Order Proposal shall be full compensation for implementing the proposed change in the Work, including any adjustment in the Contract Sum or Contract Time, and including compensation for all delays in connection with such change in the Work and for any expense or inconvenience, disruption of schedule, or loss of efficiency or productivity occasioned by the change in the Work.
- C. Upon receipt of the Change Order proposal, or a request for equitable adjustment in the Contract Sum or Contract Time, or both, as provided in sections 7.02 and 7.03, Owner may accept or reject the proposal, request further documentation, or negotiate acceptable terms with Contractor. Pending agreement on the terms of the Change Order, Owner may direct Contractor to proceed immediately with the Change Order Work. Contractor shall not proceed with any change in the Work until it has obtained Owner's approval. All Work done pursuant to any Owner-directed change in the Work shall be executed in accordance with the Contract Documents.
- D. If Owner and Contractor reach agreement on the terms of any change in the Work, including any adjustment in the Contract Sum or Contract Time, such agreement shall be incorporated in a Change Order. The Change Order shall constitute full payment and final settlement of all claims for time and for direct, indirect, and consequential costs, including costs of delays, inconvenience, disruption of schedule, or loss of efficiency or productivity, related to any Work either covered or affected by the Change Order, or related to the events giving rise to the request for equitable adjustment.

GENERAL CONDITIONS FOR CONSTRUCTION AT WASHINGTON STATE PARKS

- E. If Owner and Contractor are unable to reach agreement on the terms of any change in the Work, including any adjustment in the Contract Sum or Contract Time, Contractor may at any time in writing, request a final offer from Owner. Owner shall provide Contractor with its written response within 30 (thirty) days of Contractor's request. Owner may also provide Contractor with a final offer at any time. If Contractor rejects Owner's final offer, or the parties are otherwise unable to reach agreement, Contractor's only remedy shall be to file a Claim as provided in part 8.
- F. Field Authorization
1. The Field Authorization (FA) is executed as a directive to proceed with work when the processing time for an approved change order would impact the project.
 2. A scope of work must be defined, a maximum not to exceed cost agreed upon, and any estimated modification to the contract completion time determined. The method of final cost verification must be noted and supporting cost data must be submitted in accordance with the requirements of Part 7 of the General Conditions. Upon satisfactory submittal and approval of supporting cost data, the completed FA will be processed into a change order. No payment will be made to the Contractor for FA work until that FA is converted to a Change Order.

7.02 CHANGES IN THE CONTRACT SUM

- A. General Application
1. The Contract Sum shall only be changed by a Change Order. Contractor shall include any request for a change in the Contract Sum in its Change Order Proposal.
 2. If the cost of Contractor's performance is changed due to the fault or negligence of Owner, or anyone for whose acts Owner is responsible, Contractor shall be entitled to make a request for an equitable adjustment in the Contract Sum in accordance with the following procedure. No change in the Contract Sum shall be allowed to the extent: Contractor's changed cost of performance is due to the fault or negligence of Contractor, or anyone for whose acts Contractor is responsible; the change is concurrently caused by Contractor and Owner; or the change is caused by an act of Force Majeure as defined in Section 3.05.
 - a. A request for an equitable adjustment in the Contract Sum shall be based on written notice delivered to Owner within 7 (seven) days of the occurrence of the event giving rise to the request. For purposes of this part, "occurrence" means when Contractor knew, or in its diligent prosecution of the Work should have known, of the event giving rise to the request. If Contractor believes it is entitled to an adjustment in the Contract Sum, Contractor shall immediately notify Owner and begin to keep and maintain complete, accurate, and specific daily records. Contractor shall give Owner access to any such records and, if requested shall promptly furnish copies of such records to Owner.
 - b. Contractor shall not be entitled to any adjustment in the Contract Sum for any occurrence of events or costs that occurred more than 7 (seven) days before Contractor's written notice to Owner. The written notice shall set forth, at a minimum, a description of: the event giving rise to the request for an equitable adjustment in the Contract Sum; the nature of the impacts to Contractor and its Subcontractors of any tier, if any; and to the extent possible the amount of the adjustment in Contract Sum requested. Failure to properly give such written notice shall, to the extent Owner's interests are prejudiced, constitute a waiver of Contractor's right to an equitable adjustment.
 - c. Within 30 (thirty) days of the occurrence of the event giving rise to the request, unless Owner agrees in writing to allow an additional period of time to ascertain more accurate data, Contractor shall supplement the written notice provided in accordance with subparagraph a. above with additional supporting data. Such additional data shall include, at a minimum: the amount of compensation requested, itemized in accordance with the procedure set forth herein; specific facts, circumstances, and analysis that confirms not only that Contractor suffered the damages claimed, but that the damages claimed were actually a result of the act, event, or condition complained of and that the Contract Documents provide entitlement to an equitable adjustment to Contractor for such act, event, or condition; and documentation sufficiently detailed to permit an informed analysis

GENERAL CONDITIONS FOR CONSTRUCTION AT WASHINGTON STATE PARKS

of the request by Owner. When the request for compensation relates to a delay, or other change in Contract Time, Contractor shall demonstrate the impact on the critical path, in accordance with section 7.03C. Failure to provide such additional information and documentation within the time allowed or within the format required shall, to the extent Owner's interests are-prejudiced, constitute a waiver of Contractor's right to an equitable adjustment.

- d. Pending final resolution of any request made in accordance with this paragraph, unless otherwise agreed in writing, Contractor shall proceed diligently with performance of the Work.
 - e. Any requests by Contractor for an equitable adjustment in the Contract Sum and in the Contract Time that arise out of the same event(s) shall be submitted together.
3. The value of any Work covered by a Change Order, or of any request for an equitable adjustment in the Contract Sum, shall be determined by one of the following methods:
 - a. On the basis of a fixed price as determined in paragraph 7.02B.
 - b. By application of unit prices to the quantities of the items involved as determined in paragraph 7.02C.
 - c. On the basis of time and material as determined in paragraph 7.02D.
 4. When Owner has requested Contractor to submit a Change Order proposal, Owner may direct Contractor as to which method in subparagraph 3 above to use when submitting its proposal. Otherwise, Contractor shall determine the value of the Work, or a request for an equitable adjustment, on the basis of the fixed price method.

B. Change Order Pricing -- Fixed Price

When the fixed price method is used to determine the value of any Work covered by a Change Order or a request for an equitable adjustment in the Contract Sum, the following procedures shall apply:

1. Contractor's Change Order Proposal, or request for adjustment in the Contract Sum, shall be accompanied by a complete itemization of the costs, including labor, material, subcontractor costs, and overhead and profit. The costs shall be itemized in the manner set forth below, and shall be submitted on breakdown sheets in a form approved by Owner.
2. All costs shall be calculated based upon appropriate industry standard methods of calculating labor, material quantities, and equipment costs.
3. If any of Contractor's pricing assumptions are contingent upon anticipated actions of Owner, Contractor shall clearly state them in the proposal or request for an equitable adjustment.
4. The cost of any additive or deductive changes in the Work shall be calculated as set forth below, except that overhead and profit shall not be included on deductive changes in the Work. Where a change in the Work involves additive and deductive work by the same Contractor or Subcontractor, small tools, overhead, profit, bond, and insurance markups will apply to the net difference.
5. If the total cost of the change in the Work or request for equitable adjustment does not exceed \$1,000, Contractor shall not be required to submit a breakdown if the description of the change in the Work or request for equitable adjustment is sufficiently definitive for Owner to determine fair value.
6. If the total cost of the change in the Work or request for equitable adjustment is between \$1,000 and \$2,500, Contractor may submit a breakdown in the following level of detail if the description of the change in the Work or if the request for equitable adjustment is sufficiently definitive to permit the Owner to determine fair value:
 - a. lump sum labor;
 - b. lump sum material;
 - c. lump sum equipment usage;
 - d. overhead and profit as set forth below; and
 - e. insurance and bond costs as set forth below.

GENERAL CONDITIONS FOR CONSTRUCTION AT WASHINGTON STATE PARKS

7. Any request for adjustment of Contract Sum based upon the fixed price method shall include only the following items:
- a. Craft labor costs: These are the labor costs determined by multiplying the estimated or actual additional number of craft hours needed to perform the change in the Work by the hourly labor costs. Craft hours should cover direct labor, as well as indirect labor due to trade inefficiencies. The hourly costs shall be based on the following:
 - 1) Basic wages and benefits: Hourly rates and benefits as stated on the Department of Labor and Industries approved "statement of intent to pay prevailing wages." Direct supervision shall be a reasonable percentage not to exceed 15% (fifteen percent) of the cost of direct labor. No supervision markup shall be allowed for a working supervisor's hours.
 - 2) Worker's insurance: Direct contributions to the state of Washington for industrial insurance; medical aid; and supplemental pension, by the class and rates established by the Department of Labor and Industries.
 - 3) Federal insurance: Direct contributions required by the Federal Insurance Compensation Act; Federal Unemployment Tax Act; and the State Unemployment Compensation Act.
 - 4) Travel allowance: Travel allowance and/or subsistence, if applicable, not exceeding those allowances established by regional labor union agreements, which are itemized and identified separately.
 - 5) Safety: Cost incurred due to the Washington Industrial Safety and Health Act, which shall be a reasonable percentage not to exceed 2% (two percent) of the sum of the amounts calculated in (1), (2), and (3) above.
 - b. Material costs: This is an itemization of the quantity and cost of materials needed to perform the change in the Work. Material costs shall be developed first from actual known costs, second from supplier quotations or if these are not available, from standard industry pricing guides. Material costs shall consider all available discounts. Freight costs, express charges, or special delivery charges, shall be itemized.
 - c. Equipment costs: This is an itemization of the type of equipment and the estimated or actual length of time the construction equipment appropriate for the Work is or will be used on the change in the Work. Costs will be allowed for construction equipment only if used solely for the changed Work, or for additional rental costs actually incurred by the Contractor. Equipment charges shall be computed on the basis of actual invoice costs or if owned, from the current edition of one of the following sources:
 - 1) Associated General Contractors - Washington State Department of Transportation (AGC-WSDOT) Equipment Rental Agreement; current edition, on the Contract execution date.
 - 2) The state of Washington Utilities and Transportation Commission for trucks used on highways.
 - 3) The National Electrical Contractors Association for equipment used on electrical work.
 - 4) The Mechanical Contractors Association of America for equipment used on mechanical work.

The Data Quest Rental Rate (Blue Book) shall be used as a basis for establishing rental rates of equipment not listed in the above sources. The maximum rate for standby equipment shall not exceed that shown in the AGC WSDOT Equipment Rental Agreement, current edition, on the Contract execution date.
 - d. Allowance for small tools, expendables, and consumable supplies: Small tools consist of tools which cost \$250 or less and are normally furnished by the performing contractor. The maximum rate for small tools shall not exceed the following:

GENERAL CONDITIONS FOR CONSTRUCTION AT WASHINGTON STATE PARKS

- 1) For Contractor, 3% (three percent) of direct labor costs.
- 2) For Subcontractors, 5% (five percent) of direct labor costs.

Expendables and consumable supplies directly associated with the change in Work must be itemized.

- e. Subcontractor costs: This is defined as payments Contractor makes to Subcontractors for changed Work performed by Subcontractors of any tier. The Subcontractors' cost of Work shall be calculated and itemized in the same manner as prescribed herein for Contractor.
- f. Allowance for overhead: This is defined as costs of any kind attributable to direct and indirect delay, acceleration, or impact, added to the total cost to Owner of any change in the Contract Sum but not to the cost of any change in the Contract Time for which contractor has been compensated pursuant to the conditions set forth in Section 7.03. This allowance shall compensate Contractor for all non-craft labor, temporary construction facilities, field engineering, schedule updating, record drawings, home office cost, B&O taxes, office engineering, estimating costs, additional overhead because of extended time, and any other cost incidental to the change in the Work. It shall be strictly limited in all cases to a reasonable amount, mutually acceptable, or if none can be agreed upon to an amount not to exceed the rates below:

1) For projects where the Contract Award Amount is under \$3 million, the following shall apply:

- a) For Contractor, for any Work actually performed by Contractor's own forces, 16% (sixteen percent) of the first \$50,000 of the cost, and 4% (four percent) of the remaining cost, if any.
- b) For each Subcontractor (including lower tier subcontractors), for any Work actually performed by its own forces, 16% (sixteen percent) of the first \$50,000 of the cost, and 4% (four percent) of the remaining cost, if any.
- c) For Contractor, for any work performed by its Subcontractor(s), 6% (six percent) of the first \$50,000 of the amount due each Subcontractor, and 4% (four percent) of the remaining amount if any.
- d) For each Subcontractor, for any Work performed by its Subcontractor(s) of any lower tier, 4% (four percent) of the first \$50,000 of the amount due the sub-Subcontractor, and 2% (two percent) of the remaining amount if any.
- e) The cost to which overhead is to be applied shall be determined in accordance with subparagraphs a.-e. above.

2) For projects where the Contract Award Amount is equal to or exceeds \$3 million, the following shall apply:

- a) For Contractor, for any Work actually performed by Contractor's own forces, 12% (twelve percent) of the first \$50,000 of the cost, and 4% (four percent) of the remaining cost, if any.
- b) For each Subcontractor (including lower tier subcontractors), for any Work actually performed by its own forces, 12% (twelve percent) of the first \$50,000 of the cost, and 4% (four percent) of the remaining cost, if any.
- c) For Contractor, for any Work performed by its Subcontractor(s), 4% (four percent) of the first \$50,000 of the amount due each Subcontractor, and 2% (two percent) of the remaining amount if any.
- d) For each Subcontractor, for any Work performed by its Subcontractor(s) of any lower tier, 4% (four percent) of the first \$50,000 of the amount due the sub-Subcontractor, and 2% (two percent) of the remaining amount if any.

GENERAL CONDITIONS FOR CONSTRUCTION AT WASHINGTON STATE PARKS

- e) The cost to which overhead is to be applied shall be determined in accordance with subparagraphs a.- e. above.
- g. Allowance for profit: This is an amount to be added to the cost of any change in contract sum, but not to the cost of change in Contract Time for which contractor has been compensated pursuant to the conditions set forth in section 7.03. It shall be limited to a reasonable amount, mutually acceptable, or if none can be agreed upon, to an amount not to exceed the rates below:
 - 1) For Contractor or Subcontractor of any tier for work performed by their forces, 6% (six percent) of the cost developed in accordance with Section 7.02 b. 7a.- e.
 - 2) For Contractor or Subcontractor of any tier for work performed by a subcontractor of a lower tier, 4% (four percent) of the Subcontractor cost developed in accordance with Section 7.02 b. 7a. - h.
- h. Cost of change in insurance or bond premium: This is defined as:
 - 1) Contractor's liability insurance: The cost of any changes in Contractor's liability insurance arising directly from execution of the Change Order; and
 - 2) Public works bond: The cost of the additional premium for Contractor's bond arising directly from the changed Work.

The costs of any change in insurance or bond premium shall be added after overhead and allowance for profit are calculated in accordance with subparagraph f. and g. above.

C. Change Order Pricing -- Unit Prices

- 1. Whenever Owner authorizes Contractor to perform Work on a unit-price basis, Owner's authorization shall clearly state:
 - a. Scope of work to be performed;
 - b. Type of reimbursement including pre-agreed rates for material quantities; and
 - c. Cost limit of reimbursement.
- 2. Contractor shall:
 - a. Cooperate with Owner and assist in monitoring the Work being performed. As requested by Owner, Contractor shall identify workers assigned to the Change Order Work and areas in which they are working;
 - b. Leave access as appropriate for quantity measurement; and
 - c. Not exceed any cost limit(s) without Owner's prior written approval.
- 3. Contractor shall submit costs in accordance with paragraph 7.02B. and satisfy the following requirements:
 - a. Unit prices shall include reimbursement for all direct and indirect costs of the Work, including overhead and profit, and bond and insurance costs; and
 - b. Quantities must be supported by field measurement statements signed by Owner.

D. Change Order Pricing -- Time-and-Material Prices

- 1. Whenever Owner authorizes Contractor to perform Work on a time-and-material basis, Owner's authorization shall clearly state:
 - a. Scope of Work to be performed;
 - b. Type of reimbursement including pre-agreed rates, if any, for material quantities or labor; and
 - c. Cost limit of reimbursement.
- 2. Contractor shall:

GENERAL CONDITIONS FOR CONSTRUCTION AT WASHINGTON STATE PARKS

- a. Cooperate with Owner and assist in monitoring the Work being performed. As requested by Owner, identify workers assigned to the Change Order Work and areas in which they are working;
 - b. Identify on daily time sheets all labor performed in accordance with this authorization. Submit copies of daily time sheets within 2 working days for Owner's review;
 - c. Leave access as appropriate for quantity measurement;
 - d. Perform all Work in accordance with this section as efficiently as possible; and
 - e. Not exceed any cost limit(s) without Owner's prior written approval.
3. Contractor shall submit costs in accordance with paragraph 7.02B and additional verification supported by:
- a. Labor detailed on daily time sheets; and
 - b. Invoices for material.

7.03 CHANGES IN THE CONTRACT TIME

- A. The Contract Time shall only be changed by a Change Order. Contractor shall include any request for a change in the Contract Time in its Change Order Proposal.
- B. If the time of Contractor's performance is changed due to an act of Force Majeure, or due to the fault or negligence of Owner or anyone for whose acts Owner is responsible, Contractor shall be entitled to make a request for an equitable adjustment in the Contract Time in accordance with the following procedure. No adjustment in the Contract Time shall be allowed to the extent Contractor's changed time of performance is due to the fault or negligence of Contractor, or anyone for whose acts Contractor is responsible.
1. A request for an equitable adjustment in the Contract Time shall be based on written notice delivered within 7 (seven) days of the occurrence of the event giving rise to the request. If Contractor believes it is entitled to adjustment of Contract Time, Contractor shall immediately notify Owner and begin to keep and maintain complete, accurate, and specific daily records. Contractor shall give Owner access to any such record and if requested, shall promptly furnish copies of such record to Owner.
 2. Contractor shall not be entitled to an adjustment in the Contract Time for any events that occurred more than 7 (seven) days before Contractor's written notice to Owner. The written notice shall set forth, at a minimum, a description of: the event giving rise to the request for an equitable adjustment in the Contract Time; the nature of the impacts to Contractor and its Subcontractors of any tier, if any; and to the extent possible the amount of the adjustment in Contract Time requested. Failure to properly give such written notice shall, to the extent Owner's interests are prejudiced, constitute a waiver of Contractor's right to an equitable adjustment.
 3. Within 30 (thirty) days of the occurrence of the event giving rise to the request, unless Owner agrees in writing to allow an additional period of time to ascertain more accurate data, Contractor shall supplement the written notice provided in accordance with subparagraph 7.03B.2 with additional supporting data. Such additional data shall include, at a minimum: the amount of delay claimed, itemized in accordance with the procedure set forth herein; specific facts, circumstances, and analysis that confirms not only that Contractor suffered the delay claimed, but that the delay claimed was actually a result of the act, event, or condition complained of, and that the Contract Documents provide entitlement to an equitable adjustment in Contract Time for such act, event, or condition; and supporting documentation sufficiently detailed to permit an informed analysis of the request by Owner. Failure to provide such additional information and documentation within the time allowed or within the format required shall, to the extent Owner's interests are prejudiced, constitute a waiver of Contractor's right to an equitable adjustment.
 4. Pending final resolution of any request in accordance with this paragraph, unless otherwise agreed in writing, Contractor shall proceed diligently with performance of the Work.
- C. Any change in the Contract Time covered by a Change Order, or based on a request for an equitable adjustment in the Contract Time, shall be limited to the change in the critical path of Contractor's schedule attributable to the change of Work or event(s) giving rise to the request for equitable adjustment. Any Change Order proposal or request for an adjustment in the Contract Time shall demonstrate the impact on the critical path of the schedule. Contractor shall be responsible for showing clearly on the Progress

GENERAL CONDITIONS FOR CONSTRUCTION AT WASHINGTON STATE PARKS

Schedule that the change or event: had a specific impact on the critical path, and except in case of concurrent delay, was the sole cause of such impact; and could not have been avoided by resequencing of the Work or other reasonable alternatives.

- D. Contractor may request compensation for the cost of a change in Contract Time in accordance with this paragraph, 7.03D, subject to the following conditions:
1. The change in Contract Time shall solely be caused by the fault or negligence of Owner or A/E;
 2. Compensation under this paragraph is limited to changes in Contract Time for which Contractor is not entitled to be compensated under section 7.02;
 3. Contractor shall follow the procedure set forth in paragraph 7.03B;
 4. Contractor shall establish the extent of the change in Contract Time in accordance with paragraph 7.03C; and
 5. The daily cost of any change in Contract Time shall be limited to the items below, less funds that may have been paid pursuant to a change in the Contract Sum that contributed to this change in Contract Time:
 - a. cost of nonproductive field supervision or labor extended because of the delay;
 - b. cost of weekly meetings or similar indirect activities extended because of the delay;
 - c. cost of temporary facilities or equipment rental extended because of the delay;
 - d. cost of insurance extended because of the delay;
 - e. general and administrative overhead in an amount to be agreed upon, but not to exceed 3% (three percent) of Contract Sum divided by the Contract Time for each day of the delay.

PART 8 - CLAIMS AND DISPUTE RESOLUTION

8.01 CLAIMS PROCEDURE

- A. If the parties fail to reach agreement on the terms of any Change Order for Owner-directed Work as provided in section 7.01, or on the resolution of any request for an equitable adjustment in the Contract Sum as provided in section 7.02 or the Contract Time as provided in section 7.03, Contractor's only remedy shall be to file a Claim with Owner as provided in this section.
- B. Contractor shall file its Claim within the earlier of: 120 (one hundred twenty) days from Owner's final offer in accordance with either paragraph 7.01E or the date of Final Acceptance.
- C. The Claim shall be deemed to cover all changes in cost and time (including direct, indirect, impact, and consequential) to which Contractor may be entitled. It shall be fully substantiated and documented. At a minimum, the Claim shall contain the following information:
1. A detailed factual statement of the Claim for additional compensation and time, if any, providing all necessary dates, locations, and items of Work affected by the Claim;
 2. The date on which facts arose which gave rise to the Claim
 3. The name of each employee of Owner or A/E knowledgeable about the Claim;
 4. The specific provisions of the Contract Documents which support the Claim;
 5. The identification of any documents and the substance of any oral communications that support the Claim;
 6. Copies of any identified documents, other than the Contract Documents, that support the Claim;
 7. If an adjustment in the Contract Time is sought: the specific days and dates for which it is sought; the specific reasons Contractor believes an extension in the Contract Time should be granted; and

GENERAL CONDITIONS FOR CONSTRUCTION AT WASHINGTON STATE PARKS

Contractor's analysis of its Progress Schedule to demonstrate the reason for the extension in Contract Time;

8. If an adjustment in the Contract Sum is sought, the exact amount sought and a breakdown of that amount into the categories set forth in, and in the detail required by, section 7.02; and
 9. A statement certifying, under penalty of perjury, that the Claim is made in good faith, that the supporting cost and pricing data are true and accurate to the best of Contractor's knowledge and belief, that the Claim is fully supported by the accompanying data, and that the amount requested accurately reflects the adjustment in the Contract Sum or Contract Time for which Contractor believes Owner is liable.
- D. After Contractor has submitted a fully documented Claim that complies with all applicable provisions of parts 7 and 8, Owner shall respond, in writing, to Contractor as follows:
1. If the Claim amount is less than \$50,000, with a decision within 60 (sixty) days from the date the Claim is received; or
 2. If the Claim amount is \$50,000 or more, with a decision within 60 (sixty) days from the date the Claim is received, or with notice to Contractor of the date by which it will render its decision. Owner will then respond with a written decision in such additional time.
- E. To assist in the review of Contractor's Claim, Owner may visit the Project site, or request additional information, in order to fully evaluate the issues raised by the Claim. Contractor shall proceed with performance of the Work pending final resolution of any Claim. Owner's written decision as set forth above shall be final and conclusive as to all matters set forth in the Claim, unless Contractor follows the procedure set forth in section 8.02.
- F. Any Claim of the Contractor against the Owner for damages, additional compensation, or additional time, shall be conclusively deemed to have been waived by the Contractor unless timely made in accordance with the requirements of this section.

8.02 ARBITRATION

- A. If Contractor disagrees with Owner's decision rendered in accordance with paragraph 8.01D, Contractor shall provide Owner with a written demand for arbitration. No demand for arbitration of any such Claim shall be made later than 30 (thirty) days after the date of Owner's decision on such Claim; failure to demand arbitration within said 30-day period shall result in Owner's decision being final and binding upon Contractor and its Subcontractors.
- B. Notice of the demand for arbitration shall be filed with the American Arbitration Association (AAA), with a copy provided to Owner. The parties shall negotiate or mediate under the Voluntary Construction Mediation Rules of the AAA, or mutually acceptable service, before seeking arbitration in accordance with the Construction Industry Arbitration Rules of AAA as follows:
1. Disputes involving \$30,000 or less shall be conducted in accordance with the Northwest Region Expedited Commercial Arbitration Rules; or
 2. Disputes over \$30,000 shall be conducted in accordance with the Construction Industry Arbitration Rules of the AAA, unless the parties agree to use the expedited rules.
- C. All Claims arising out of the Work shall be resolved by arbitration. The judgment upon the arbitration award may be entered, or review of the award may occur, in the superior court having jurisdiction thereof. No independent legal action relating to or arising from the Work shall be maintained.
- D. Claims between Owner and Contractor, Contractor and its Subcontractors, Contractor and A/E, and Owner and A/E shall, upon demand by Owner, be submitted in the same arbitration or mediation.
- E. If the parties resolve the Claim prior to arbitration judgment, the terms of the resolution shall be incorporated in a Change Order. The Change Order shall constitute full payment and final settlement of the Claim, including all claims for time and for direct, indirect, or consequential costs, including costs of delays, inconvenience, disruption of schedule, or loss of efficiency or productivity.

GENERAL CONDITIONS FOR CONSTRUCTION AT WASHINGTON STATE PARKS

8.03 CLAIMS AUDITS

- A. All Claims filed against Owner shall be subject to audit at any time following the filing of the Claim. Failure of Contractor, or Subcontractors of any tier, to maintain and retain sufficient records to allow Owner to verify all or a portion of the Claim or to permit Owner access to the books and records of Contractor, or Subcontractors of any tier, shall constitute a waiver of the Claim and shall bar any recovery.
- B. In support of Owner audit of any Claim, Contractor shall, upon request, promptly make available to Owner the following documents:
1. Daily time sheets and supervisor's daily reports;
 2. Collective bargaining agreements;
 3. Insurance, welfare, and benefits records;
 4. Payroll registers;
 5. Earnings records;
 6. Payroll tax forms;
 7. Material invoices, requisitions, and delivery confirmations;
 8. Material cost distribution worksheet;
 9. Equipment records (list of company equipment, rates, etc.);
 10. Vendors', rental agencies', Subcontractors', and agents' invoices;
 11. Contracts between Contractor and each of its Subcontractors, and all lower-tier Subcontractor contracts and supplier contracts;
 12. Subcontractors' and agents' payment certificates;
 13. Cancelled checks (payroll and vendors);
 14. Job cost report, including monthly totals;
 15. Job payroll ledger;
 16. Planned resource loading schedules and summaries;
 17. General ledger;
 18. Cash disbursements journal;
 19. Financial statements for all years reflecting the operations on the Work. In addition, the Owner may require, if it deems it appropriate, additional financial statements for 3 (three) years preceding execution of the Work;
 20. Depreciation records on all company equipment whether these records are maintained by the company involved, its accountant, or others;
 21. If a source other than depreciation records is used to develop costs for Contractor's internal purposes in establishing the actual cost of owning and operating equipment, all such other source documents;
 22. All non-privileged documents which relate to each and every Claim together with all documents which support the amount of any adjustment in Contract Sum or Contract Time sought by each Claim;
 23. Work sheets or software used to prepare the Claim establishing the cost components for items of the Claim including but not limited to labor, benefits and insurance, materials, equipment, Subcontractors,

GENERAL CONDITIONS FOR CONSTRUCTION AT WASHINGTON STATE PARKS

all documents which establish the time periods, individuals involved, the hours for the individuals, and the rates for the individuals; and

24. Work sheets, software, and all other documents used by Contractor to prepare its bid.

- C. The audit may be performed by employees of Owner or a representative of Owner. Contractor, and its Subcontractors, shall provide adequate facilities acceptable to Owner, for the audit during normal business hours. Contractor, and all Subcontractors, shall make a good faith effort to cooperate with Owner's auditors.

PART 9 - TERMINATION OF THE WORK

9.01 TERMINATION BY OWNER FOR CAUSE

- A. Owner may, upon 7 (seven) days written notice to Contractor and to its surety, terminate (without prejudice to any right or remedy of Owner) the Work, or any part of it, for cause upon the occurrence of any one or more of the following events:
1. Contractor fails to prosecute the Work or any portion thereof with sufficient diligence to ensure Substantial Completion of the Work within the Contract Time;
 2. Contractor is adjudged bankrupt, makes a general assignment for the benefit of its creditors or a receiver is appointed on account of its insolvency;
 3. Contractor fails in a material way to replace or correct Work not in conformance with the Contract Documents;
 4. Contractor repeatedly fails to supply skilled workers or proper materials or equipment;
 5. Contractor repeatedly fails to make prompt payment due to Subcontractors or for labor;
 6. Contractor materially disregards or fails to comply with laws, ordinances, rules, regulations, or orders of any public authority having jurisdiction; or
 7. Contractor is otherwise in material breach of any provision of the Contract Documents.
- B. Upon termination, Owner may at its option:
1. Take possession of the Project site and take possession of or use all materials, equipment, tools, and construction equipment and machinery thereon owned by Contractor to maintain the orderly progress of, and to finish, the Work;
 2. Accept assignment of subcontracts pursuant to section 5.20; and
 3. Finish the Work by whatever other reasonable method it deems expedient.
- C. Owner's rights and duties upon termination are subject to the prior rights and duties of the surety, if any, obligated under any bond provided in accordance with the Contract Documents.
- D. When Owner terminates the Work in accordance with this section, Contractor shall take the actions set forth in paragraph 9.02B, and shall not be entitled to receive further payment until the Work is accepted.
- E. If the unpaid balance of the Contract Sum exceeds the cost of finishing the Work, including compensation for A/E's services and expenses made necessary thereby and any other extra costs or damages incurred by Owner in completing the Work, or as a result of Contractor's actions, such excess shall be paid to Contractor. If such costs exceed the unpaid balance, Contractor shall pay the difference to Owner. These obligations for payment shall survive termination.
- F. Termination of the Work in accordance with this section shall not relieve Contractor or its surety of any responsibilities for Work performed.

GENERAL CONDITIONS FOR CONSTRUCTION AT WASHINGTON STATE PARKS

- G. If Owner terminates Contractor for cause, and it is later determined that none of the circumstances set forth in paragraph 9.01A exist, then such termination shall be deemed a termination for convenience pursuant to section 9.02.

9.02 TERMINATION BY OWNER FOR CONVENIENCE

- A. Owner may, upon written notice, terminate (without prejudice to any right or remedy of Owner) the Work, or any part of it, for the convenience of Owner.
- B. Unless Owner directs otherwise, after receipt of a written notice of termination for either cause or convenience, Contractor shall promptly:
1. Stop performing Work on the date and as specified in the notice of termination;
 2. Place no further orders or subcontracts for materials, equipment, services or facilities, except as may be necessary for completion of such portion of the Work as is not terminated;
 3. Cancel all orders and subcontracts, upon terms acceptable to Owner, to the extent that they relate to the performance of Work terminated;
 4. Assign to Owner all of the right, title, and interest of Contractor in all orders and subcontracts;
 5. Take such action as may be necessary or as directed by Owner to preserve and protect the Work, Project site, and any other property related to this Project in the possession of Contractor in which Owner has an interest; and
 6. Continue performance only to the extent not terminated.
- C. If Owner terminates the Work or any portion thereof for convenience, Contractor shall be entitled to make a request for an equitable adjustment for its reasonable direct costs incurred prior to the effective date of the termination, plus a reasonable allowance for overhead and profit on Work performed prior to termination, plus the reasonable administrative costs of the termination, but shall not be entitled to any other costs or damages, whatsoever, provided however, the total sum payable upon termination shall not exceed the Contract Sum reduced by prior payments. Contractor shall be required to make its request in accordance with the provisions of part 7.
- D. If Owner terminates the Work or any portion thereof for convenience, the Contract Time shall be adjusted as determined by Owner.

PART 10 - MISCELLANEOUS PROVISIONS

10.01 GOVERNING LAW

The Contract Documents and the rights of the parties herein shall be governed by the laws of the state of Washington. Venue shall be in the county in which Owner's principal place of business is located, unless otherwise specified.

10.02 SUCCESSORS AND ASSIGNS

Owner and Contractor respectively bind themselves, their partners, successors, assigns, and legal representatives to the other party hereto and to partners, successors, assigns, and legal representatives of such other party in respect to covenants, agreements, and obligations contained in the Contract Documents. Neither party shall assign the Work without written consent of the other, except that Contractor may assign the Work for security purposes, to a bank or lending institution authorized to do business in the state of Washington. If either party attempts to make such an assignment without such consent, that party shall nevertheless remain legally responsible for all obligations set forth in the Contract Documents.

10.03 MEANING OF WORDS

Unless otherwise stated in the Contract Documents, words which have well-known technical or construction industry meanings are used in the Contract Documents in accordance with such recognized meanings. Reference to standard specifications, manuals, or codes of any technical society, organization, or association, or

GENERAL CONDITIONS FOR CONSTRUCTION AT WASHINGTON STATE PARKS

to the code of any governmental authority, whether such reference be specific or by implication, shall be to the latest standard specification, manual, or code in effect on the date for submission of bids, except as may be otherwise specifically stated. Wherever in these Drawings and Specifications an article, device, or piece of equipment is referred to in the singular manner, such reference shall apply to as many such articles as are shown on the drawings, or required to complete the installation.

10.04 RIGHTS AND REMEDIES

No action or failure to act by Owner or A/E shall constitute a waiver of a right or duty afforded them under the Contract Documents, nor shall such action or failure to act constitute approval of an acquiescence in a breach therein, except as may be specifically agreed in writing.

10.05 CONTRACTOR REGISTRATION

Pursuant to RCW 39.06, Contractor shall be registered or licensed as required by the laws of the State of Washington, including but not limited to RCW 18.27.

10.06 TIME COMPUTATIONS

When computing any period of time, the day of the event from which the period of time begins shall not be counted. The last day is counted unless it falls on a weekend or legal holiday, in which event the period runs until the end of the next day that is not a weekend or holiday. When the period of time allowed is less than 7 (seven) days, intermediate Saturdays, Sundays, and legal holidays are excluded from the computation.

10.07 RECORDS RETENTION

The wage, payroll, and cost records of Contractor, and its Subcontractors, and all records subject to audit in accordance with section 8.03, shall be retained for a period of not less than 6 (six) years after the date of Final Acceptance.

10.08 THIRD-PARTY AGREEMENTS

The Contract Documents shall not be construed to create a contractual relationship of any kind between: A/E and Contractor; Owner and any Subcontractor; or any persons other than Owner and Contractor.

10.09 ANTITRUST ASSIGNMENT

Owner and Contractor recognize that in actual economic practice, overcharges resulting from antitrust violations are in fact usually borne by the purchaser. Therefore, Contractor hereby assigns to Owner any and all claims for such overcharges as to goods, materials, and equipment purchased in connection with the Work performed in accordance with the Contract Documents, except as to overcharges which result from antitrust violations commencing after the Contract Sum is established and which are not passed on to Owner under a Change Order. Contractor shall put a similar clause in its Subcontracts, and require a similar clause in its sub-Subcontracts, such that all claims for such overcharges on the Work are passed to Owner by Contractor.

10.10 MINORITY AND WOMEN'S BUSINESS ENTERPRISES (MWBE) PARTICIPATION

In Accordance with the legislative findings and policies set forth in Chapter 39.19 RCW the State of Washington encourages participation in all of its contracts by MWBE firms certified by the Office of Minority and Women's Business Enterprises (OMWBE). Participation may be either on a direct basis in response to this solicitation or as a subcontractor to a Bidder. Any affirmative action requirements set forth in federal regulations or statutes included or referenced in the contract documents will apply. Bidders may contact OMWBE to obtain information on certified firms for potential subcontractors/suppliers.

- A. When referred to in this Contract, the terms Minority Business Enterprise (MBE) and Women's Business Enterprise (WBE) will be as defined by OMWBE, WAC 326-02-030.

GENERAL CONDITIONS FOR CONSTRUCTION AT WASHINGTON STATE PARKS

- B. The OMWBE has compiled a directory of certified firms. Copies of this directory may be obtained through the OMWBE. For information regarding the certification process or the certification status of a particular firm, contact:
- OMWBE, 406 South Water Street, PO Box 41160, Olympia, WA 98504-1160, telephone (360) 753-9693.
- C. Eligible MWBEs or M/W firms
- MWBE firms utilized for this project for voluntary MWBE goals may be certified by Washington State OMWBE or self identified as minority or women owned (M/W firm).
- D. MWBE Voluntary Goals
- The Owner has established voluntary goals for MWBE participation for this project. The voluntary goals are set forth in the Advertisement for Bids.
- E. If any part of the contract, including the supply of materials and equipment, is anticipated to be subcontracted, then prior to receipt of the first payment, Contractor shall submit, pursuant to Section 5.20 A, a list of all subcontractors/suppliers it intends to use, designate whether any of the subcontractors/suppliers are MWBE firms, indicate the anticipated dollar value of each MWBE subcontract, and provide Tax Identification Number (TIN).
- F. If any part of the contract, including the supply of materials and equipment is actually subcontracted during completion of the work, then prior to final acceptance or completion of the contract or as otherwise indicated in the contract documents, the Contractor shall submit a statement of participation indicating what MWBEs were used and the dollar value of their subcontracts.
- G. The provisions of this section are not intended to replace or otherwise change the requirements of RCW 39.30.060. If said statute is applicable to this contract then the failure to comply with RCW 39.30.060 will still render a bid non-responsive.
- H. The Contractor shall maintain, for at least three years after completion of this contract, relevant records and information necessary to document the level of utilization of MWBEs and other businesses as subcontractors and suppliers in this contract, as well as any efforts the Contractor makes to increase the participation of MWBEs as listed in section I below. The Contractor shall also maintain, for at least three years after completion of this contract, a record of all quotes, bids, estimates, or proposals submitted to the Contractor by all businesses seeking to participate as subcontractors or suppliers in this contract. The state shall have the right to inspect and copy such records. If this contract involves federal funds, Contractor shall comply with all record keeping requirements set forth in any federal rules, regulations, or statutes included or referenced in the contract documents.
- I. Bidders should advertise opportunities for subcontractors or suppliers in a manner reasonably designed to provide MWBEs capable of performing the work with timely notice of such opportunities, and all advertisements shall include a provision encouraging participation by MWBE firms. Advertising may be done through general advertisements (e.g. newspapers, journals, etc.) or by soliciting bids directly from MWBEs. Bidders shall provide MWBEs that express interest with adequate and timely information about plans, specifications, and requirements of the contract.
- J. Contractors shall not create barriers to open and fair opportunities for all businesses including MWBEs to participate in all State contracts and to obtain or compete for contracts and subcontracts as sources of supplies, equipment, construction and services.
- K. Any violation of the mandatory requirements of this part of the contract shall be a material breach of contract for which the Contractor may be subject to a requirement of specific performance, or damages and sanctions provided by contract, by RCW 39.19.090, or by other applicable laws.

10.11 MINIMUM LEVELS OF APPRENTICESHIP PARTICIPATION

In accordance with Executive Order 00-01 the State of Washington may require apprenticeship participation for projects of a certain cost. The bid advertisement and Bid Proposal form shall establish the minimum percentage of apprentice labor hours as compared to the total labor hours.

GENERAL CONDITIONS FOR CONSTRUCTION AT WASHINGTON STATE PARKS

- A. Voluntary workforce diversity goals have been established for the apprentice hours. These goals are that one-fifth (1/5) of the apprentice hours be performed by minorities, and one-sixth (1/6) of the apprentice hours be performed by women.
- B. Apprentice participation, under this contract, may be counted towards the required percentage (%) only if the apprentices are from an apprenticeship program registered and approved by the Washington State Apprenticeship and Training Council (RCW 49.04 and WAC 296-04).
- C. Bidders may contact the Department of Labor and Industries, Specialty Compliance Services Division, Apprenticeship Section, P.O. Box 44530, Olympia, WA 98504-4530 by phone at (360) 902-5320, and e-mail at thum235@lni.wa.gov, to obtain information on available apprenticeship programs.
- D. For each project that has apprentice requirements, the contractor shall submit a "Statement of Apprentice/Journeyman Participation" on forms provided by the Department of General Administration, with every request for progress payment. The Contractor shall submit consolidated and cumulative data collected by the Contractor and collected from all subcontractors by the Contractor. The data to be collected and submitted includes the following:
1. Contractor name and address
 2. Contract number
 3. Project name
 4. Contract value
 5. Reporting period "Notice to Proceed" through "Invoicing Date"
 6. Craft/trade/occupation of all (contractor and subcontractor trades working on the project) apprentices and journeymen
 7. Total number of apprentices and total number of hours worked by apprentices, both categorized by gender and ethnicity
 8. Total number of journeymen and total number of hours worked by journeymen, both categorized by gender and ethnicity
 9. Cumulative combined total of apprentice and journeymen labor hours.
 10. Total percentage of apprentice hours worked
 11. No changes to the required percentage (%) of apprentice participation shall be allowed without written approval of the Owner. In any request for the change the Contractor shall clearly demonstrate a good faith effort to comply with the requirements for apprentice participation.
 12. Any substantive violation of the mandatory requirements of this part of the contract may be a material breach of the contract by the Contractor. The Owner may withhold payment pursuant to Part 6.05, stop the work for cause pursuant to Part 3.04, and terminate the contract for cause pursuant to Part 9.01.

10.12 HEADINGS AND CAPTIONS

Headings for convenience only: All headings and captions used in these General Conditions are only for convenience of reference, and shall not be used in any way in connection with the meaning, effect, interpretation, construction, or enforcement of the General Conditions, and do not define the limit or describe the scope or intent of any provision of these General Conditions.

END OF CONDITIONS

/ / / / /

Approved as to Form:
William Van Hook /s/
Asst. Attorney General
02/2007
08/2010 GA Updates – jrc
09/2010 to AAG Schwartz

PREVAILING WAGES

The State of Washington prevailing wage rates for this public works project, which is located in Pierce County, may be found at the following website address of the Department of Labor and Industries:

<https://secure.lni.wa.gov/wagelookup/>.

The prevailing wages for this project are those that are in effect on the date that the bids are due.

A copy of the applicable wage rates is available for viewing at the Washington State Parks and Recreation Commission: Contracts, Grants, and Procurement Office, 1111 Israel Road SW, Tumwater, WA 98501-6512, or Washington State Parks and Recreation Commission will mail a hard copy of the applicable wage rates upon request. Please telephone (360) 902-8554; or email at: contracts@parks.wa.gov.

**KOPACHUCK STATE PARK
DAY USE DEVELOPMENT**

SECTION 010000 – GENERAL REQUIREMENTS

PART 1 - GENERAL

1.1 DESCRIPTION OF WORK

- A. The project consists of work related to day use area development including removal of an existing restroom building, construction of a new Day Use Building and deck, Welcome Center building, wood decks, ramps, and stairs, wood amphitheater, concrete ADA accessible paths, picnic areas, play area elements, play tower structure, faux water feature, park entry gateway and sign, concrete walls, paved one-way parking lot with 98 stalls, vehicular gates, and school connector trail / pathway along the south side of 56th St NW. Work includes clearing, grading, concrete, asphalt, sanitary sewer, storm sewer, domestic water, electrical systems, CCTV system, and landscape planting.

1.2 TIME FOR COMPLETION OF PROJECT

- A. Substantially complete project in accordance with the drawings and specifications within 365 calendar days from date on Notice to Proceed letter. Final completion in accordance with Contract Documents within 30 calendar days from substantial completion date.

1.3 HOURS OF WORK

- A. Work hours are between 7 a.m. and 5 p.m. Monday through Friday, excluding national holidays.

1.4 LIQUIDATED DAMAGES

- A. If Contractor fails to complete Contract within stipulated time, an assessment of \$1000.00 per day will be made against Contractor for each additional day required to complete contract, unless an extension of time was granted through Change Order. This assessment is to cover Commission's liquidated damages and is not to be construed as a penalty.
- B. Contract authorizes the Washington State Parks and Recreation Commission to deduct liquidated damages from money due at completion of contract.

1.5 PRE-CONSTRUCTION CONFERENCE

- A. Following notification of award to Contractor, the date for an on-site pre-construction conference will be set. Do not commence Work prior to conference or until written clearance has been obtained from Project Representative.
- B. Furnish Project Representative with following:

**KOPACHUCK STATE PARK
DAY USE DEVELOPMENT**

1. Complete list of sub-contractors, including business address, telephone numbers, items of Work, and registration numbers. List is to be updated during contract life.
2. Name and contact information of Contractor's staff who is in charge and responsible for site safety and will be on site at all times.
3. A Site-Specific Safety Plan that is in compliance with the Department of Labor and Industries and 000011 – General Conditions specifically for this project.
4. A progress schedule in accordance with General Conditions.
5. A detailed cost breakdown for lump sum bid items. Furnish a fair evaluation of actual cost of each items of Work listed. This will be used in processing Contractor's requests for partial payment. Submittal of breakdown does not affect the Contract terms.
6. Written document detailing plans to comply with 15 percent Apprenticeship Participation requirement stated in Instruction to Bidders 4.1B.

- C. Project Representative will supply a list of hazardous products that could be encountered on Project. Appropriate Safety Data Sheet (SDS) will be on file at park.

1.6 PROGRESS CLEANING

- A. Remove rubbish and debris from park property daily unless otherwise directed do not allow accumulation. Store materials that cannot be removed daily only in areas specified by the Project Representative.
- B. Maintain worksites in a neat and orderly condition.
- C. Cleanup operations are incidental to the Contract and no extra compensation will be made.

1.7 WASHINGTON STATE DEPARTMENT OF TRANSPORTATION (WSDOT)

- A. **None** of WSDOT General Requirements, measurement or payment provisions apply.

1.8 AS-BUILT DRAWINGS

- A. Keep a clean set of full-sized drawings at job site to use to identify changes.

1.9 PROJECT CONDITIONS

- A. Hazardous Materials: Hazardous materials are present in construction affected by removal and dismantling work. A report on the presence of hazardous materials is on file for review and use. Examine report to become aware of locations where hazardous materials are present.
1. Hazardous material remediation is specified elsewhere in the Contract Documents.
 2. Do not disturb hazardous materials or items suspected of containing hazardous materials except under procedures specified elsewhere in the Contract Documents.

**KOPACHUCK STATE PARK
DAY USE DEVELOPMENT**

1.10 PROJECT SIGN

- A. Provide following temporary sign. Sign location is shown on drawings or determined by Project Representative. Upon Project completion, remove sign and restore area to original condition.

1.11 PROJECT SIGN LETTERING

TITLE OF PROJECT:	KOPACHUCK DAY USE IMPROVEMENTS
NAME OF FACILITY:	KOPACHUCK STATE PARK
NAME OF CONTRACTOR:	(Place Contractor's Name here)
ADDRESS OF CONTRACTOR:	(Place Contractor's Address here)
FUNDING TITLE NUMBER 1:	STATE BUILDING CONSTRUCTION ACCOUNT
FUNDING TITLE NUMBER 2:	(LEAVE BLANK FOR THIS PROJECT)

1.12 PARTNERSHIP IN THE CONTRACT

- A. As partners in this contract, both Contractor and Commission recognize the value of a successful Project. Both parties recognize, besides the tangible benefits to Contractor and the Commission, the citizens of Washington State and visitors to Washington State Parks will benefit immensely from the successful completion of a quality Project.

PART 2 - PRODUCTS (NOT USED)

PART 3 - EXECUTION (NOT USED)

**KOPACHUCK STATE PARK
DAY USE DEVELOPMENT**

PROJECT SIGN DETAIL

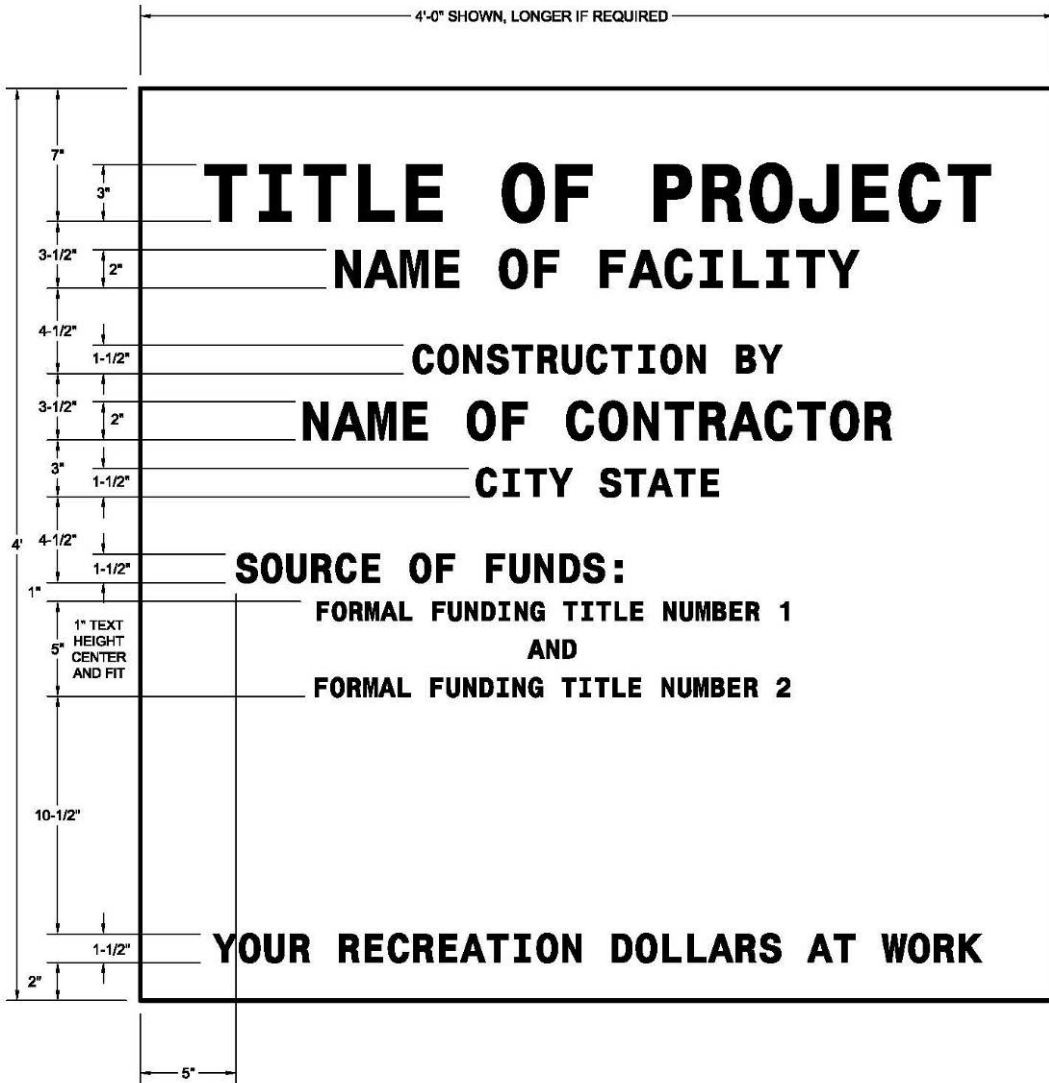

LAY OUT SIGN TO FIT ON A PORTION OF ONE (1) SHEET OF PLYWOOD. IF PLYWOOD IS THE FINAL SURFACE, PAINT IT WITH TWO (2) OR MORE COATS OF WHITE PAINT TO FORM A SMOOTH, NONABSORBENT SURFACE. PROVIDE DARK GREEN WELL FORMED LETTERS, EVENLY SPACED, NEAT IN APPEARANCE, AND ALIGNED AS SHOWN ABOVE.

**WASHINGTON STATE PARKS
PROJECT SIGN DETAIL**

**KOPACHUCK STATE PARK
DAY USE DEVELOPMENT**

PROJECT SIGN DETAIL

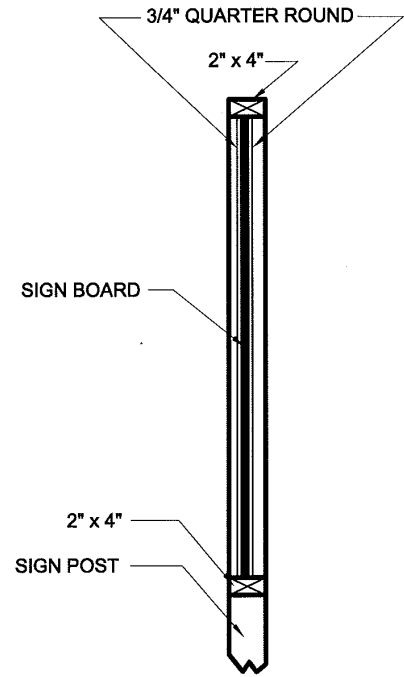
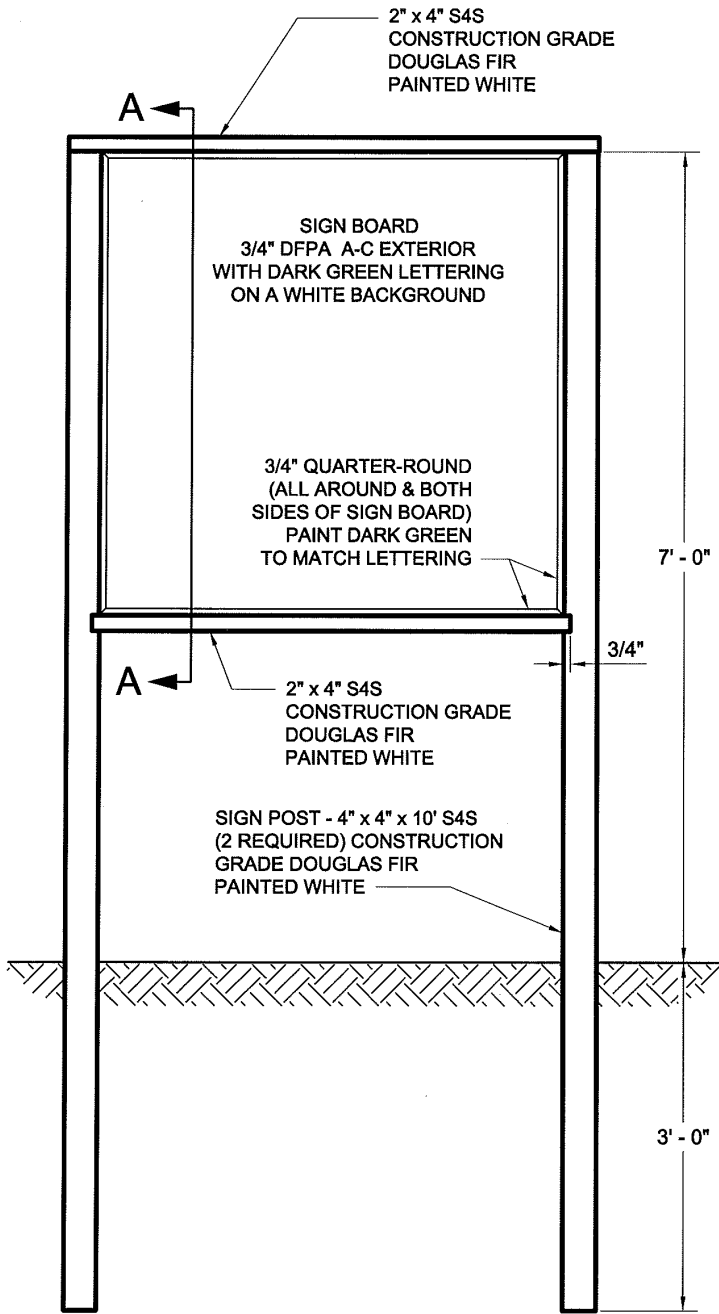

SECTION A - A

END OF SECTION

**KOPACHUCK STATE PARK
DAY USE DEVELOPMENT**

SECTION 010099 – SURVEYING

PART 1 - GENERAL

1.1 DESCRIPTION OF WORK

- A. This section addresses work covered by Base Bid and awarded Alternates.
- B. Set and maintain alignment and grades necessary for construction; including clearing limits, grading, utilities, roads, trails, and structures. Except for the data specified to be furnished by the Owner, the Contractor is responsible for calculations, surveying materials and measuring required for setting and maintaining the necessary lines and grades. Furnish copies of calculations and staking data, when requested by Project Representative. AutoCAD design data will be provided as noted on Contract Drawings.
- C. Staking requirements that do not fit field conditions will be reviewed and, if necessary, adjusted by the Engineer. Revisions to the staking information will be provided for completing the work.

1.2 SURVEY CONTROL AND DATA

- A. To facilitate establishment of lines and elevations, Owner will furnish the following survey control and data:
 - 1. Elevation benchmarks, and horizontal control points, for one time only.
 - 2. Provide technical advice, if requested.
- B. Give three weeks' notice to allow adequate time to provide data.

1.3 TOLERANCES

- A. Ensure accuracy of line and elevations within a tolerance of 0.01 foot.
- B. Set subgrade blue tops and surfacing red and yellow tops at min. 50-foot intervals in tangent sections, min. 25-foot intervals in curve sections and min. 10-foot intervals in intersection radii.
- C. In disputes concerning line and elevation accuracy, resolve dispute to Project Representative's satisfaction. Correct discrepancies before proceeding. No additional time or compensation will be provided for corrective work.

1.4 PAYMENT

- A. Lump sum price for "Surveying" includes full pay costs for labor, tools, survey instruments, materials, other equipment, and traffic control necessary for the setting and maintaining horizontal locations and grades as specified.

**KOPACHUCK STATE PARK
DAY USE DEVELOPMENT**

PART 2 – PRODUCTS (NOT USED)

PART 3 – EXECUTION (NOT USED)

END OF SECTION

**KOPACHUCK STATE PARK
DAY USE DEVELOPMENT**

SECTION 012300 – ALTERNATES

PART 1 - GENERAL

1.1 SUMMARY

- A. Section includes administrative and procedural requirements for alternates.

1.2 DEFINITIONS

- A. Alternate: An amount proposed by bidders and stated on the Bid Form for certain work defined in the Bidding Requirements that may be added to or deducted from the base bid amount if Owner decides to accept a corresponding change either in the amount of construction to be completed or in the products, materials, equipment, systems, or installation methods described in the Contract Documents.
 - 1. Alternates described in this Section are part of Work only if accepted by the Commission.
 - 2. The cost or credit for each alternate is the net addition to or deduction from Contract Sum to incorporate alternate into Work. No other adjustments are made to Contract Sum.

1.3 PROCEDURES

- A. Coordination: Modify or adjust affected adjacent work as necessary to completely integrate work of the alternate into Project.
 - 1. Include as part of each alternate, miscellaneous devices, accessory objects, and similar items incidental to or required for a complete installation whether or not indicated as part of alternate.
- B. Execute accepted alternates under the same conditions as other work of Contract.
- C. Schedule: A schedule of alternates is included at the end of this Section. Specification Sections referenced in schedule contain requirements for materials necessary to achieve work described under each alternate.

1.4 REINSTATEMENT OF BID ALTERNATES

- A. The Commission reserves the right to reinstate, within sixty (60) calendar days after Notice to Proceed date, any bid alternates not incorporated into the contract, at the stated alternate bid price.

1.5 ORDER OF CONSIDERATION

- A. Bid alternates may be selected in any order or combination by the Commission in any order.

**KOPACHUCK STATE PARK
DAY USE DEVELOPMENT**

PART 2 - PRODUCTS (NOT USED)

PART 3 - EXECUTION

3.1 SCHEDULE OF ALTERNATES

- A. Alternate No. A1 – Wood Deck/Ramp & Stairs from Day Use Area to Beach Trail:
1. Alternate Includes: That portion of wood deck, ramps, & stairs extending from the east side of Day Use Building entry and connecting to the beach area trails where shown on Contract Documents. Includes all materials required for construction of this section of wood decking, ramps, stairs, handrails, framing, posts, beams, bracing, diamond pier footings, and connection to Base Bid wood decking at entrance to Day Use Building where shown. (Note: Alternate A1 must be awarded if Alternate A2 is awarded.)
- B. Alternate No. A2 – Amphitheater Wood Deck, Ramp, Steps, and Seating:
1. Alternate Includes: Wood amphitheater deck, ramp, steps and seating located off wood deck/ramp connecting Day Use Building entry to beach area trails (Alternate No. A1) where shown on Contract Documents. Includes all materials required for construction of amphitheater wood decking, ramp, steps, seating, handrails, framing, posts, beams, bracing, diamond pier footings, and connection to Alternate A1 wood decking where shown.
- C. Alternate No. A3 – Welcome Center Wood Stairs:
1. Alternate Includes: Wood stairs and deck connecting the plaza near the Welcome Center to the play area perimeter path where shown on Contract Documents. Includes all materials required for construction of wood decking, stairs, handrails, framing, posts, beams, bracing, diamond pier footings, and concrete footing shown.
- D. Alternate No. A4 – School Connector Trail and Small Parking Lot along 56th St NW:
1. Alternate Includes: All work related to construction of the trail/pathway and small parking lot shown along the south side of 56th St NW where shown on Contract Documents including, clearing, demolition, grading, surfacing, curbing, paving, striping signage, landscape, etc.
- E. Alternate No. A5 – Day Use to Beach Area Trails:
1. Alternate Includes: All work related to construction of the trail/pathways between the day use area Stair (Alternate A1) to the existing beach area drive where shown on Contract Documents including, clearing, demolition, minor grading, surfacing, landscape steps, etc. (Note: Storm drainage work in this area is included in Base Bid.)

**KOPACHUCK STATE PARK
DAY USE DEVELOPMENT**

- F. Alternate No. A6 – Use of On-site Salvaged Wood Material for Play Tower Structure Poles in Lieu of Purchased Poles:
 - 1. Alternate Includes: Use of on-site wood pole material in lieu of purchased wood pole material for construction of the play area tower structure. This could be an add or a deduct from the Base Bid amount.

- G. Alternate No. A7 – Use of On-site Salvaged Wood Material for Park Entry Gate Structure Poles in Lieu of Purchased Poles:
 - 1. Alternate Includes: Use of on-site wood pole material in lieu of purchased wood pole material for construction of the park entry gateway / sign structure. This could be an add or a deduct from the Base Bid amount.

END OF SECTION

**KOPACHUCK STATE PARK
DAY USE DEVELOPMENT**

SECTION 013300 – SUBMITTAL PROCEDURES

PART 1 – GENERAL

1.1 WORK IN THIS SECTION

- A. General: The types of submittal requirements specified in this Section include Shop Drawings, product data, Samples and miscellaneous Work-related submittals. Specialized submittal requirements are specified in applicable Sections for each unit of Work. Refer to other Division 01 Sections and other Contract documents for requirements of administrative submittals.
- B. Definitions: Work-related submittals of this Section are categorized for convenience as follows:
 - 1. Shop Drawings: Specially-prepared technical data for this Project, including Drawings, diagrams, performance curves, data sheets, schedules, templates, patterns, reports, calculations, instructions, measurements and similar information not in standard printed form for general application to several projects.
 - 2. Product Data: Standard printed information on materials, products and systems; not specially-prepared for this Project, other than the designation of selections from among available choices printed therein.
 - 3. Samples: Fabricated and unfabricated physical examples of materials, products and units of Work; both as completed units and as smaller portions of units of Work; either for limited visual inspection or (where indicated) for more detailed testing and analysis.
 - 4. Miscellaneous: Submittals related directly to the Work (non-administrative) include warranties, informational, maintenance agreements, workmanship bonds, Project photographs, survey data and reports, physical Work records, quality testing and certifying reports, copies of industry standards, record drawings, field measurement data, operating and maintenance materials, overrun stock, and similar information, devices and materials applicable to the Work and not processed as Shop Drawings, product data or Samples. See Specification Sections.

1.2 RELATED REQUIREMENTS

- A. General Conditions 4.03
- B. Section 014000 – Quality Requirements
- C. Section 017700 – Closeout Procedures

1.3 GENERAL SUBMITTAL REQUIREMENTS

- A. Coordination and Sequencing: Coordinate preparation and processing of submittals with performance of the Work so that Work will not be delayed by submittals. Coordinate and sequence different categories of submittals for same Work, and for interfacing units of Work, so that one will not be delayed for coordination with another.

**KOPACHUCK STATE PARK
DAY USE DEVELOPMENT**

- B. Preparation of Submittals: Provide permanent marking on, or with, each submittal to identify Project, date, Contractor, sub-contractor, submittal name and similar information to distinguish it from other submittals.

1.4 SPECIFIC SUBMITTAL REQUIREMENTS

A. General:

- 1. Except as otherwise indicated in individual Work Sections, comply with requirements specified herein for each indicated category of submittal.
- 2. Provide and process intermediate submittals, where required between initial and final, similar to initial submittals.
- 3. Include a transmittal with all submittals.

B. Shop Drawings:

- 1. General: No claims for extras may be initiated, based on Work shown on Shop Drawings.
- 2. Where Work of more than one sub-contractor is involved, submit composite Drawings, clearly defining the Work of each separate sub-contractor.
- 3. No extension of time in respect to the final completion date of building will be granted to Contractor because of failure to have any Shop Drawings submitted in ample time to allow for checking.
- 4. Verify all dimensions by taking field measurements. Do not begin Work until required submittals have been returned by the Engineer with stamp and initials indicating review. If Work has been done which is contrary to the approved Drawings, it will be corrected at no additional cost to the Commission. Maintain one complete set of shop drawings at the site for use by the Engineer.
- 5. Submit four (4) copies. Engineer will retain two (2) copies and return two (2) copies.

C. Product Data:

- 1. General:
 - a. Collect required data into one submittal for each unit of Work or system; and mark each copy to show which choices and options are applicable to Project. Include manufacturer's standard printed recommendations for application and use, compliance with standards, application of labels and seals, notation of field measurements which have been checked, and modify details as required for application into the Work. Include color selection information where necessary.
 - b. Do not proceed with installation of materials, products or systems until final copy of applicable product data is in possession of Installer. Maintain one complete set of product data at the site for use by Project Representative.
- 2. Preparation and Processing: Do not submit product data, or allow its use on the Project, until compliance with requirements of Contract documents has been confirmed by Contractor. Submittal is for information and record, unless otherwise indicated. Initial submittal is final submittal unless returned by Engineer, marked with an "Action" which indicates an observed noncompliance.

**KOPACHUCK STATE PARK
DAY USE DEVELOPMENT**

3. Submit four (4) copies. Engineer will retain two (2) copies and return two (2) copies to the Contractor.

D. Samples:

1. General: Provide units identical with final condition of proposed materials or products for the Work. Include "range" Samples (not less than three (3) units) where there are unavoidable variations between units of each set. Provide full set of optional Samples where Engineer's selection is required. Prepare Samples to match Engineer's sample where indicated. Include information with each sample to show generic description, source or product name and manufacturer, limitations, and compliance with standards. Samples are submitted for review and confirmation of color, pattern, texture and "kind" by Engineer. Engineer will not "test" Samples (except as otherwise indicated) for compliance with other requirements, which are, therefore, for exclusive responsibility of the Contractor.
2. Processing: Submit two (2) sets of Samples for Engineer's review and "Action"; one (1) set will be returned. Large Samples, which may be incorporated into the Work, may be submitted singly.
3. Reusable Samples: Returned Samples which are intended or permitted to be incorporated in the Work are so indicated in the individual Work sections, and must be in undamaged condition at time of use.

- E. Warranties and Guarantees: In addition to copies desired for Contractor's use, furnish three (3) executed copies, except furnish additional copies where required for maintenance manuals.

- F. Survey Data: Refer to other Sections for specific general requirements on property surveys, field measurements, quantitative records of actual Work, damage surveys, photographs and similar data required by individual Work Sections of these specifications. None of specified copies will be returned.

1.5 ACTION ON SUBMITTALS

- A. Engineer's Action: Engineer will review each submittal, mark with "Action", and where possible return within two (2) weeks of receipt. Where submittal must be held for coordination, they will be returned to the Contractor within two (2) weeks of receipt for the Contractor to resubmit when it is appropriate.

1. Final Unrestricted Release: Work may proceed, provided it complies with Contract documents, when submittal is returned with marking: "Approved as Submitted".
2. Final-But-Restricted Release: Work may proceed, provided it complies with notations and corrections on submittal and with Contract documents, when submittal is returned with the marking: "Approved as Noted".
3. Returned and Rejected: Do not proceed with Work. Submittal item is not acceptable and may not be used on the Project when noted as "Not Approved".

**KOPACHUCK STATE PARK
DAY USE DEVELOPMENT**

PART 2 - PRODUCTS (NOT USED)

PART 3 - EXECUTION (NOT USED)

END OF SECTION

KOPACHUCK STATE PARK
DAY USE DEVELOPMENT

SECTION 013301- SUBMITTAL TRANSMITTAL

SUBMITTAL TRANSMITTAL

Project: _____

Date: _____

A/E Project Number: _____

Transmittal
A
To: Bruce Dees & Associates
222 E. 26th Street, Suite 202
Tacoma, WA 98421

Contractor Submittal Reference Number: _____

From: (Contractor)
Address
City, ST ZIP

By:

Qty.	Submittal Item No.	Description	Spec. Section Title and Paragraph / Drawing Detail Reference

Submitted for review

Substitution involved – Substitution request attached with point-by-point comparative data or preliminary details.

Resubmitted for review

Other remarks on above submission:

Transmittal
B
To: (Contractor)

Attn:

Date Received by A/E:

B

From: Bruce Dees & Associates

By:

Date Transmitted by A/E:

Conforms to Design Concept

Non-Conformance – Revise & Resubmit

Conforms to Design Concept with Revisions/Notations as Noted

Submission Incomplete / Resubmit

Not subject to review

No action required

Other remarks on above submission:

**KOPACHUCK STATE PARK
DAY USE DEVELOPMENT**

SECTION 013501 – INADVERTENT DISCOVERIES OF CULTURAL RESOURCES AND HUMAN
SKELETAL REMAINS

PART 1 - GENERAL

1.1 PROJECT SPECIFIC REQUIREMENTS

- A. No cultural resource sites are known to exist within Work area. However, there always exist the potential for unanticipated discoveries during excavation work.

1.2 EMERGENCY CONTACTS

WSPRC Archaeologists

Jennifer Wilson, Archaeology Program Manager	(360) 787-6511 (cell)
Email: jennifer.wilson@parks.wa.gov	(360) 902-8637 (office)
Shari Silverman, Archaeologist SW Region	(435) 260-9894 (cell)
Email: shari.silverman@parks.wa.gov	(360) 902- 8640 (office)
Kayley Bass, Archaeologist SW Region	(360) 701-1277 (cell)
Emails: kayley.bass@parks.wa.gov	
Sarah DuBois, Archaeologist Eastern Region	(509) 972-5884 (cell)
Email: sarah.dubois@parks.wa.gov	(509) 665-4336 (office)
Ayla Aymond, Archaeologist Eastern Region	(509) 743-8251 (cell)
Email: ayla.aymond@parks.wa.gov	
Sean Stcherbinine, Archaeologist NW Region	(360) 770-1419 (cell)
Email: sean.stcherbinine@parks.wa.gov	
Laura Syvertson, Archaeologist NW Region	(360) 770-0444 (cell)
Email: laura.syvertson@parks.wa.gov	
Maurice Major, Stewardship Archaeologist	(360) 701-6218 (cell)
Email: maurice.major@parks.wa.gov	(360) 902-8503 (office)

WSPRC Curator of Collections/NAGPRA Specialist

Alicia L. Woods, Statewide Curator of Collections & NAGPRA Specialist (360) 586-0206 (office)

State Physical Anthropologist

Guy Tasa, PhD, Dept. of Archaeology and Historic Preservation (360) 790-1633 (cell)

Assistant State Physical Anthropologist

Julie Berger, Dept. of Archaeology and Historic Preservation (360) 890-2633 (cell)

County Coroner/Examiner

Karen Cline-Parhamovich, DO (Chief Medical Examiner) (253) 798-6494

**KOPACHUCK STATE PARK
DAY USE DEVELOPMENT**

Area Manager

Olyvia Buday, Area Manager, South Sound Area

(253) 884-2524 (office)
(360) 401-5494 (cell)

Region Manager

Darrel Hopkins

(360) 725-9781

Local Law Enforcement (if can't get ahold of any park staff)

Michael Farley, Belfair State Park

360-628-4234 (phone)
Michael.Farley@parks.wa.gov

1.3 INADVERTENT DISCOVERIES OF CULTURAL RESOURCES AND HUMAN SKELETAL REMAINS

- A. Many of Washington's most important heritage sites reside on lands owned or managed by the Washington State Parks and Recreation Commission (WSPRC). Nearly all Washington State Parks contain one or more important historic buildings, structures, or archaeological sites. For this reason, archaeological surveys and historic building inventories are ordinarily commissioned as a part of background analysis and information gathering for park developments and undertakings. Results of these surveys are used during project planning to ensure every effort is made to avoid impacts to cultural resources. Yet, despite these efforts, there **always** remains some potential for unanticipated discoveries while working in Washington State Parks.
- B. All unanticipated discoveries, both cultural resources and human skeletal remains, are subject to all applicable federal and state statutes, regulations, and executive orders. For these reasons, the Inadvertent Discovery Plan (IDP) provides useful guidance and instructions for circumstances when cultural resources or human skeletal remains are found. Please carefully read these instructions. If you have any questions, please contact the appropriate WSPRC Area Manager or the WSPRC archaeologist assigned to the undertaking. It is also strongly recommended that anyone conducting ground-disturbing activities watch the training video produced by Washington State Dept of Ecology: [Inadvertent Discovery of Cultural Resources or Human Remains: Training for Field Staff](#). This IDP for cultural resources and human skeletal remains is based on [RCW 27.53](#), [RCW 68.50.645](#), [RCW 27.44.055](#), and [RCW 68.60.055](#) and [recommended language](#) from the Department of Archaeology and Historic Preservation (DAHP).

1.4 INADVERTENT DISCOVERY PLAN FOR CULTURAL RESOURCES

- A. If cultural resources are found during a project, activity in the immediate area of the find should be discontinued (**stop**), the area secured (**protect**), and the WSPRC archaeologists notified to assess the find (**notify**). *When in doubt, assume the material is a cultural resource and implement the IDP outlined below.*
- B. **Recognizing Cultural Resources-Types of Historic/Prehistoric Artifacts and/or Activity Areas That May Be Found**
1. Artifacts- Both historic and prehistoric artifacts may be found exposed in backhoe trenches or back dirt piles.

KOPACHUCK STATE PARK DAY USE DEVELOPMENT

- a) Prehistoric artifacts may range from finished tools such as stone pestles, arrowheads/projectile points, shell beads, or polished bone tools to small pieces or “flakes” or “chips” of exotic stone such as chert, jasper, or obsidian.
 - b) Historic artifacts may include older (more than 50 years) nails, plates/ceramics, bottles, cans, coins, glass insulators, or bricks.
 - c) Old abandoned industrial materials from farming, logging, railways, lighthouses, and military installations.
2. Activity Area/Cultural Features- While excavating trench lines look for evidence of buried activity areas/cultural features such as old campfire hearths or buried artifacts.
- a) An area of charcoal or very dark stained soil with artifacts or burned rocks may be a fire hearth.
 - b) A concentration of shell with or without artifacts may be shell midden deposits.
 - c) Modified or stripped trees, often cedar or aspen, or other modified natural features, such as rock drawings or carvings
3. Historic building foundation/structural remains- During excavation, buried historic structures (e.g., privies, building foundations) that are more than 50 years old may be found.
4. Bone- Complete or broken pieces of bones may be discovered exposed in trench walls or in back dirt piles. Bone of recent age is usually transparent or white in color. Older bone is usually found in various shades of brown. Burned bone is usually black or, if heavily burned, bluish-white.
- C. STEPS TO TAKE IF A CULTURAL RESOURCE IS FOUND DURING CONSTRUCTION
1. **Stop** if a cultural resource(s) is observed or suspected, all work within the immediate area of the discovery must stop.
 2. **Protect** the area from further disturbance. Do not touch, move, or further disturb the exposed materials/artifacts. Create a protected area with temporary fencing, flagging, stakes, or other clear markings that is large enough (30 feet or larger) to protect the discovery location area. The WSPRC archaeologist can help determine the size of the protected area. Do not permit vehicles, equipment, or unauthorized personnel to traverse the discovery site.
 3. **Notify** the WSPRC archaeologist. If the area needs to be secured, notify the Park Ranger or Park staff as well.
 4. If requested by the WSPRC archaeologist, take photographs with a scale (e.g., pen, coin, etc.) and collect geospatial information of the discovery site to document the initial finds.
- D. WHAT NOT TO DO IF A CULTURAL RESOURCE IS FOUND DURING CONSTRUCTION
1. Do not remove any artifacts from the site of the discovery.
 2. Do not dig out objects protruding from any trench walls as this may cause further damage to artifacts and/or destroy important contextual information.
 3. Do not share any information about the find, including on social media, except as necessary to implement the IDP.
- E. WHAT HAPPENS NEXT?
1. The find will be assessed by a professional archaeologist (may be a WSPRC archaeologist or an archaeology consultant).

KOPACHUCK STATE PARK DAY USE DEVELOPMENT

- a) If the find is not a cultural resource, construction work may resume.
 - b) If the find is a cultural resource, the WSPRC archaeologist will contact the DAHP and affected Tribes, as appropriate, to develop a suitable treatment plan for the resource.
2. Construction work may resume in the protected area after the WSPRC archaeologist assigned to the undertaking has determined that the find has been adequately investigated and, if necessary, a treatment plan and monitor are in place to protect any remaining archaeological deposits.

1.5 INADVERTENT DISCOVERY PLAN FOR HUMAN SKELETAL REMAINS

A. Native American burials and historic grave sites are uncommon features on Washington State Park lands. These remains, as well as any associated artifacts or funerary objects, are protected under state law and, if the park is a federal lease, applicable federal law. If you discover human remains (or bones that you believe may be human remains) during construction, please follow these important instructions. It is imperative that reporting and treatment of any human remains found during construction or any ground-disturbing activities are treated with utmost dignity and respect.

B. Steps to Take If Human Skeletal Remains are Found During Construction

1. **Stop** if human skeletal remains observed or suspected, all work within the immediate area of the discovery must stop.
2. **Protect** the area from further disturbance. Do not touch, move, or further disturb the remains. Cover the remains with a tarp or other materials (not soil or rocks) for temporary protection in place and shield them from being photographed. Create a protected area with temporary fencing, flagging, stakes, or other clear markings that is large enough (30 feet or larger) to protect the discovery location area. The WSPRC archaeologist can help determine the size of the protected area. Do not permit vehicles, equipment, or unauthorized personnel to traverse the discovery site.
3. **Notify** law enforcement and the appropriate county medical examiner/coroner as soon as possible. If you are unsure if the remains are human, the physical anthropologist at DAHP may be called. Also notify the Park Ranger, the WSPRC archaeologist, and the WSPRC Curator of Collections/NAGRPA Specialist of the discovery of the remains.
4. If requested by law enforcement, the county coroner/examiner, the DAHP physical anthropologist, or the WSPRC archaeologist, take photographs with a scale (e.g., pen, coin, etc.) and geospatial information of the discovery site to document the initial finds.

C. What Not to Do If Human Skeletal Remains are Found During Construction

1. Do not pick up or remove anything.
2. Do not take any photographs of the remains unless instructed to do so by law enforcement, the county coroner/examiner, the DAHP physical anthropologist, or the WSPRC archaeologist. If pictures are requested, be prepared to photograph them with a scale (e.g., pen, coin, etc.) and collect geospatial information of the remains.
3. Do not call 911 unless you cannot reach law enforcement or the coroner/examiner by other means.
4. Do not share any information about the find, including on social media, except as necessary to implement the IDP.

**KOPACHUCK STATE PARK
DAY USE DEVELOPMENT**

D. What Happens Next?

1. The county medical examiner/coroner will assume jurisdiction over the human skeletal remains and decide whether those remains are forensic (crime-related) or non-forensic.
 - a) If forensic, the county medical examiner/coroner will retain jurisdiction over the remains.
 - b) If non-forensic, the county medical examiner/coroner will report that finding to the DAHP who will then take jurisdiction over the remains. The DAHP will notify any appropriate cemeteries and all affected Tribes of the remains. The State Physical Anthropologist will decide whether the remains are Indian or Non-Indian and report that finding to any appropriate cemeteries and the affected Tribes. The DAHP will then handle all consultation with the affected parties as to the future preservation, excavation, and disposition of the remains.

Note: The WSPRC archaeologist assigned to the undertaking will be coordinating and consulting with the DAHP, affected Tribes, and other groups as necessary. Additionally, WSPRC's Curator of Collections/NAGPRA Specialist should be included on all written and/or verbal correspondence until the remains have been officially transferred from WSPRC's possession to an outside authority. Until the remains are transferred off of WSPRC's property, it is the responsibility of the Curator of Collections/NAGPRA Specialist to document and track the information regarding all human remains and associated funerary objects (including all material from excavation areas/units from which the human remains were removed).

2. Construction work may resume in the protected area after the WSPRC archaeologist assigned to the undertaking has determined that the find has been adequately investigated and, if necessary, a treatment plan and monitor are in place.

PART 2 - PRODUCTS (NOT USED)

PART 3 - EXECUTION (NOT USED)

END OF SECTION

**KOPACHUCK STATE PARK
DAY USE DEVELOPMENT**

SECTION 014000 - QUALITY REQUIREMENTS

PART 1 - GENERAL

1.1 SUMMARY

- A. Section includes administrative and procedural requirements for quality assurance and quality control.
- B. Testing and inspecting services are required to verify compliance with requirements specified or indicated. These services do not relieve Contractor of responsibility for compliance with the Contract Document requirements.
 - 1. Specified tests, inspections, and related actions do not limit Contractor's other quality-assurance and -control procedures that facilitate compliance with the Contract Document requirements.
 - 2. Requirements for Contractor to provide quality-assurance and -control services required by Project Representative, Owner, or Authorities Having Jurisdiction are not limited by provisions of this Section.
- C. Related Requirements:
 - 1. Divisions 02 through 49 Sections for specific test and inspection requirements.

1.2 DEFINITIONS

- A. Quality-Assurance Services: Activities, actions, and procedures performed before and during execution of the Work to guard against defects and deficiencies and substantiate that proposed construction will comply with requirements.
- B. Quality-Control Services: Tests, inspections, procedures, and related actions during and after execution of the Work to evaluate that actual products incorporated into Work and completed construction comply with requirements. Services do not include contract enforcement activities performed by Project Representative.
- C. Mockups: Full-size physical assemblies that are constructed on-site. Mockups are constructed to verify selections made under Sample submittals; to demonstrate aesthetic effects and, where indicated, qualities of materials and execution; to review coordination, testing, or operation; to show interface between dissimilar materials; and to demonstrate compliance with specified installation tolerances. Mockups are not Samples. Unless otherwise indicated, approved mockups establish the standard by which the Work will be judged.
- D. Preconstruction Testing: Tests and inspections performed specifically for Project before products and materials are incorporated into the Work, to verify performance or compliance with specified criteria.

**KOPACHUCK STATE PARK
DAY USE DEVELOPMENT**

- E. Product Testing: Tests and inspections that are performed by an NRTL, an NVLAP, or a testing agency qualified to conduct product testing and acceptable to Authorities Having Jurisdiction, to establish product performance and compliance with specified requirements.
- F. Source Quality-Control Testing: Tests and inspections that are performed at the source, e.g., plant, mill, factory, or shop.
- G. Field Quality-Control Testing: Tests and inspections that are performed on-site for installation of the Work and for completed Work.
- H. Testing Agency: An entity engaged to perform specific tests, inspections, or both. Testing laboratory shall mean the same as testing agency.
- I. Installer/Applicator/Erector: Contractor or another entity engaged by Contractor as an employee, Subcontractor, or Sub-subcontractor, to perform a particular construction operation, including installation, erection, application, and similar operations.
 - 1. Use of trade-specific terminology in referring to a trade or entity does not require that certain construction activities be performed by accredited or unionized individuals, or that requirements specified apply exclusively to specific trade(s).
- J. Experienced: When used with an entity or individual, "experienced" means having successfully completed a minimum of [**five**] **5** previous projects similar in nature, size, and extent to this Project; being familiar with special requirements indicated; and having complied with requirements of authorities having jurisdiction.

1.3 CONFLICTING REQUIREMENTS

- A. Referenced Standards: If compliance with two or more standards is specified and the standards establish different or conflicting requirements for minimum quantities or quality levels, comply with the most stringent requirement. Refer conflicting requirements that are different, but apparently equal, to Project Representative for a decision before proceeding.
- B. Minimum Quantity or Quality Levels: The quantity or quality level shown or specified shall be the minimum provided or performed. The actual installation may comply exactly with the minimum quantity or quality specified, or it may exceed the minimum within reasonable limits. To comply with these requirements, indicated numeric values are minimum or maximum, as appropriate, for the context of requirements. Refer uncertainties to Project Representative for a decision before proceeding.

1.4 QUANTITY SHEETS/WEIGHT TICKETS

- A. For bulk items, supply quantity sheets (load receipts) to account for each load delivered to the jobsite. Deliver quantity sheets to Inspector on job at delivery time. If Inspector is not on job, deliver quantity sheets on a daily basis to place designated by Project Representative.
- B. No payment shall be made for materials delivered for which quantity tickets have not been turned into Inspector or delivered to designated place at end of working day. Backdated tickets are not acceptable as a basis for payment, except at Project Representative's discretion.

**KOPACHUCK STATE PARK
DAY USE DEVELOPMENT**

- C. If bid item for material to be delivered to jobsite is stated in TONS, only weight slips from approved scale are acceptable for payment purposes, unless approved in advance by Project Representative.
- D. No payment for materials will be made until proper accounting has been made. Final quantity records are approved by Project Representative, with payment at Project Representative's discretion.

1.5 INFORMATIONAL SUBMITTALS

- A. Contractor's Statement of Responsibility: When required by Authorities Having Jurisdiction, submit copy of written statement of responsibility sent to Authorities Having Jurisdiction before starting work on the following systems:
 - 1. Seismic-force-resisting system, designated seismic system, or component listed in the designated seismic system quality-assurance plan prepared by Engineer.
 - 2. Main wind-force-resisting system or a wind-resisting component listed in the wind-force-resisting system quality-assurance plan prepared by Engineer.
- B. Testing Agency Qualifications: For testing agencies specified in "Quality Assurance" Article to demonstrate their capabilities and experience. Include proof of qualifications in the form of a recent report on the inspection of the testing agency by a recognized authority.

1.6 REPORTS AND DOCUMENTS

- A. Test and Inspection Reports: Prepare and submit certified written reports specified in other Sections. Include the following:
 - 1. Date of issue.
 - 2. Project title and number.
 - 3. Name, address, and telephone number of testing agency.
 - 4. Dates and locations of samples and tests or inspections.
 - 5. Names of individuals making tests and inspections.
 - 6. Description of the Work and test and inspection method.
 - 7. Identification of product and Specification Section.
 - 8. Complete test or inspection data.
 - 9. Test and inspection results and an interpretation of test results.
 - 10. Record of temperature and weather conditions at time of sample taking and testing and inspecting.
 - 11. Comments or professional opinion on whether tested or inspected Work complies with the Contract Document requirements.
 - 12. Name and signature of laboratory inspector.
 - 13. Recommendations on retesting and reinspecting.
- B. Manufacturer's Field Reports: Prepare written information documenting tests and inspections specified in other Sections. Include the following:
 - 1. Name, address, and telephone number of representative making report.
 - 2. Statement on condition of substrates and their acceptability for installation of product.

**KOPACHUCK STATE PARK
DAY USE DEVELOPMENT**

3. Summary of installation procedures being followed, whether they comply with requirements and, if not, what corrective action was taken.
4. Results of operational and other tests and a statement of whether observed performance complies with requirements.
5. Other required items indicated in individual Specification Sections.

C. Permits, Licenses, and Certificates: For Owner's records, submit copies of permits, licenses, certifications, inspection reports, releases, jurisdictional settlements, notices, receipts for fee payments, judgments, correspondence, records, and similar documents, established for compliance with standards and regulations bearing on performance of the Work.

1.7 QUALITY ASSURANCE

A. General: Qualifications paragraphs in this article establish the minimum qualification levels required; individual Specification Sections specify additional requirements.

B. Manufacturer Qualifications: A firm experienced in manufacturing products or systems similar to those indicated for this Project and with a record of successful in-service performance, as well as sufficient production capacity to produce required units.

C. Fabricator Qualifications: A firm experienced in producing products similar to those indicated for this Project and with a record of successful in-service performance, as well as sufficient production capacity to produce required units.

D. Installer Qualifications: A firm or individual experienced in installing, erecting, or assembling work similar in material, design, and extent to that indicated for this Project, whose work has resulted in construction with a record of successful in-service performance.

E. Professional Engineer Qualifications: A professional engineer who is legally qualified to practice in jurisdiction where Project is located and who is experienced in providing engineering services of the kind indicated. Engineering services are defined as those performed for installations of the system, assembly, or product that are similar in material, design, and extent to those indicated for this Project.

F. Specialists: Certain Specification Sections require that specific construction activities shall be performed by entities who are recognized experts in those operations. Specialists shall satisfy qualification requirements indicated and shall be engaged for the activities indicated.

1. Requirements of Authorities Having Jurisdiction shall supersede requirements for specialists.

G. Testing Agency Qualifications: An NRTL, an NVLAP, or an independent agency with the experience and capability to conduct testing and inspecting indicated, as documented according to ASTM E329; and with additional qualifications specified in individual Sections; and, where required by Authorities Having Jurisdiction, that is acceptable to authorities.

1. NRTL: A nationally recognized testing laboratory according to 29 CFR 1910.7.
2. NVLAP: A testing agency accredited according to NIST's National Voluntary Laboratory Accreditation Program.

**KOPACHUCK STATE PARK
DAY USE DEVELOPMENT**

- H. Manufacturer's Representative Qualifications: An authorized representative of manufacturer who is trained and approved by manufacturer to observe and inspect installation of manufacturer's products that are similar in material, design, and extent to those indicated for this Project.
- I. Preconstruction Testing: Where testing agency is indicated to perform preconstruction testing for compliance with specified requirements for performance and test methods, comply with the following:
 - 1. Contractor responsibilities include the following:
 - a. Provide test specimens representative of proposed products and construction.
 - b. Submit specimens in a timely manner with sufficient time for testing and analyzing results to prevent delaying the Work.
 - c. Build laboratory mockups at testing facility using personnel, products, and methods of construction indicated for the completed Work.
 - d. When testing is complete, remove test specimens, assemblies, mockups, and laboratory mockups; do not reuse products on Project.
 - 2. Testing Agency Responsibilities: Submit a certified written report of each test, inspection, and similar quality-assurance service to Project Representative, with copy to Contractor. Interpret tests and inspections and state in each report whether tested and inspected work complies with or deviates from the Contract Documents.
- J. Mockups: Before installing portions of the Work requiring mockups, build mockups for each form of construction and finish required to comply with the following requirements, using materials indicated for the completed Work:
 - 1. Build mockups in location and of size indicated or, if not indicated, as directed by Project Representative.
 - 2. Notify Project Representative [**seven**] 7 days in advance of dates and times when mockups will be constructed.
 - 3. Demonstrate the proposed range of aesthetic effects and workmanship.
 - 4. Obtain Project Representative's approval of mockups before starting work, fabrication, or construction.
 - a. Allow [**seven**] 7 days for initial review and each re-review of each mockup.
 - 5. Maintain mockups during construction in an undisturbed condition as a standard for judging the completed Work.
 - 6. Demolish and remove mockups when directed unless otherwise indicated.

1.8 QUALITY CONTROL

- A. Owner Responsibilities: Where quality-control services are indicated as Owner's responsibility, Owner will engage a qualified testing agency to perform these services.
 - 1. Owner will furnish Contractor with names, addresses, and telephone numbers of testing agencies engaged and a description of types of testing and inspecting they are engaged to perform.

**KOPACHUCK STATE PARK
DAY USE DEVELOPMENT**

2. Costs for retesting and reinspecting construction that replaces or is necessitated by work that failed to comply with the Contract Documents will be charged to Contractor, and the Contract Sum will be adjusted by Change Order.
- B. Contractor Responsibilities: Tests and inspections not explicitly assigned to Owner are Contractor's responsibility. Perform additional quality-control activities required to verify that the Work complies with requirements, whether specified or not.
1. Where services are indicated as Contractor's responsibility, engage a qualified testing agency to perform these quality-control services.
 - a. Contractor shall not employ same entity engaged by Owner, unless agreed to in writing by Owner.
 2. Notify testing agencies at least **[twenty-four] 24** hours in advance of time when Work that requires testing or inspecting will be performed.
 3. Where quality-control services are indicated as Contractor's responsibility, submit a certified written report, in duplicate, of each quality-control service.
 4. Testing and inspecting requested by Contractor and not required by the Contract Documents are Contractor's responsibility.
 5. Submit additional copies of each written report directly to authorities having jurisdiction, when they so direct.
- C. Manufacturer's Field Services: Where indicated, engage a manufacturer's representative to observe and inspect the Work. Manufacturer's representative's services include examination of substrates and conditions, verification of materials, inspection of completed portions of the Work, and submittal of written reports.
- D. Retesting/Reinspecting: Regardless of whether original tests or inspections were Contractor's responsibility, provide quality-control services, including retesting and reinspecting, for construction that replaced Work that failed to comply with the Contract Documents.
- E. Testing Agency Responsibilities: Cooperate with Project Representative and Contractor in performance of duties. Provide qualified personnel to perform required tests and inspections.
1. Notify Project Representative and Contractor promptly of irregularities or deficiencies observed in the Work during performance of its services.
 2. Determine the location from which test samples will be taken and in which in-situ tests are conducted.
 3. Conduct and interpret tests and inspections and state in each report whether tested and inspected work complies with or deviates from requirements.
 4. Submit a certified written report, in duplicate, of each test, inspection, and similar quality-control service through Contractor.
 5. Do not release, revoke, alter, or increase the Contract Document requirements or approve or accept any portion of the Work.
 6. Do not perform any duties of Contractor.
- F. Associated Services: Cooperate with agencies performing required tests, inspections, and similar quality-control services, and provide reasonable auxiliary services as requested. Notify agency sufficiently in advance of operations to permit assignment of personnel. Provide the following:

**KOPACHUCK STATE PARK
DAY USE DEVELOPMENT**

1. Access to the Work.
 2. Incidental labor and facilities necessary to facilitate tests and inspections.
 3. Adequate quantities of representative samples of materials that require testing and inspecting. Assist agency in obtaining samples.
 4. Facilities for storage and field curing of test samples.
 5. Delivery of samples to testing agencies.
 6. Preliminary design mix proposed for use for material mixes that require control by testing agency.
 7. Security and protection for samples and for testing and inspecting equipment at Project site.
- G. Coordination: Coordinate sequence of activities to accommodate required quality-assurance and -control services with a minimum of delay and to avoid necessity of removing and replacing construction to accommodate testing and inspecting.
1. Schedule times for tests, inspections, obtaining samples, and similar activities.

1.9 SPECIAL TESTS AND INSPECTIONS

- A. Special Tests and Inspections: Owner will engage a qualified testing agency to conduct special tests and inspections required by authorities having jurisdiction as the responsibility of Owner, as indicated in Statement of Special Inspections per structural engineer's special inspections requirements on Contract Documents, and as follows:
1. Verifying that manufacturer maintains detailed fabrication and quality-control procedures and reviews the completeness and adequacy of those procedures to perform the Work.
 2. Notifying Project Representative and Contractor promptly of irregularities and deficiencies observed in the Work during performance of its services.
 3. Submitting a certified written report of each test, inspection, and similar quality-control service to Project Representative with copy to Contractor and to Authorities Having Jurisdiction.
 4. Submitting a final report of special tests and inspections at Substantial Completion, which includes a list of unresolved deficiencies.
 5. Interpreting tests and inspections and stating in each report whether tested and inspected work complies with or deviates from the Contract Documents.
 6. Retesting and reinspecting corrected work.

PART 2 - PRODUCTS (NOT USED)

PART 3 - EXECUTION

3.1 TEST AND INSPECTION LOG

- A. Test and Inspection Log: Prepare a record of tests and inspections. Include the following:
1. Date test or inspection was conducted.
 2. Description of the Work tested or inspected.

**KOPACHUCK STATE PARK
DAY USE DEVELOPMENT**

3. Date test or inspection results were transmitted to Project Representative.
 4. Identification of testing agency or special inspector conducting test or inspection.
- B. Maintain log at Project site. Post changes and revisions as they occur. Provide access to test and inspection log for Project Representative's reference during normal working hours.

3.2 REPAIR AND PROTECTION

- A. General: On completion of testing, inspecting, sample taking, and similar services, repair damaged construction and restore substrates and finishes.
1. Provide materials and comply with installation requirements specified in other Specification Sections or matching existing substrates and finishes. Restore patched areas and extend restoration into adjoining areas with durable seams that are as invisible as possible.
- B. Protect construction exposed by or for quality-control service activities.
- C. Repair and protection are Contractor's responsibility, regardless of the assignment of responsibility for quality-control services.

END OF SECTION

**KOPACHUCK STATE PARK
DAY USE DEVELOPMENT**

SECTION 014100 - REGULATORY REQUIREMENTS

PART 1 - GENERAL

1.1 PERMITS, CODES AND REGULATIONS

A. The following permits have been applied for (or are on file) and incorporated into the contract:

1. S.E.P.A. (#906884)
2. Construction Stormwater General Permit (#T.B.D.)
3. Shoreline Substantial Development (#906881)
4. Shoreline Variance (#906883)
5. Shoreline Conditional Use (#908629)
6. Geological Assessment (#922461)
7. Critical Fish & Wildlife Review (#906886 / #906888)
8. Demolition of Restroom at Day Use Area (#960173)
9. Site Development (#960672)
10. Walls at Parking Lot (#960668)
11. Entrance Pole Structure (#961639)
12. Entrance Gate (#961642)
13. Entrance Sign (#961871)
14. Wall at play Area Ramp (#960663)
15. Walls at Horseshoe Pits (#960660)
16. Stairs at Welcome Center (#960656)
17. Open Sided Pole Structure Play Tower (#960659)
18. Welcome Center Building (#971023)
19. Welcome Center Bldg. Mechanical (#971025)
20. Welcome Center Bldg. Plumbing (#971026)
21. Day Use Building Building (#970914)
22. Day Use Bldg. Mechanical (#970919)
23. Day Use Bldg. Plumbing (#970916)
24. Water Systems – Commercial (#1001712)
25. Commercial Sprinkler Underground (#1001713)
26. Minor Improvements in Existing Right-of-Way (#1013242)
27. Day Use Deck, Ramp, Stairs & Amphitheater (#1020590)
28. On Site Sewer TPCD (#SR0265350)
29. The Contractor shall obtain and pay for any other permits required.

B. The contractor shall notify the Owner and coordinate with the permitting authority for extension for all permits that expire prior to final acceptance. The Owner will be responsible for permit fees and/or related extension costs for the Owner furnished permits only unless extension is required due to Contractor error or negligence. See Appendix for list of permits and required meetings and inspections.

C. Conform with the requirements of listed permits and additional or other applicable permits, codes, and regulations as may govern Work.

**KOPACHUCK STATE PARK
DAY USE DEVELOPMENT**

- D. Obtain and pay fees for licenses, permits, inspections, and approvals required by laws, ordinances, and rules of appropriate governing or approving agencies necessary for proper completion of Work (other than those listed under item 1.1A. above and Special Inspections called for by the International Building Code).
- E. Conform with current applicable codes, regulations and standards, which is the minimum standard of quality for material and workmanship. Provide labor, materials, and equipment necessary for compliance with code requirements or interpretations, although not specifically detailed in the Drawings or specifications. Be familiar with applicable codes and standards prior to bidding.
- F. Process through Project Representative, requests to extend, modify, revise, or renew any of the permits (listed in 1.1A above). Furnish requests in writing and include a narrative description and adequate Drawings to clearly describe and depict proposed action. Do not contact regulatory agency with requests for permit extensions, modifications, revisions, or renewals without the prior written consent of Project Representative.

1.2 VARIATIONS WITH CODES, REGULATIONS AND STANDARDS

- A. Nothing in the drawings and specifications permits Work not conforming to codes, permits or regulations. Promptly submit written notice to Project Representative of observed variations or discrepancies between the Contract documents and governing codes and regulations.
- B. Appropriate modifications to the Contract documents will be made by Change Order to incorporate changes to Work resulting from code and/or regulatory requirements. Contractor assumes responsibility for Work contrary to such requirements if Work proceeds without notice.
- C. Contractor is not relieved from complying with requirements of Contract documents which may exceed, but not conflict with requirements of governing codes.

1.3 COORDINATION WITH REGULATORY AGENCIES

- A. Coordinate Work with appropriate governing or regulating authorities and agencies.
- B. Provide advance notification to proper officials of Project schedule and schedule revisions throughout Project duration, in order to allow proper scheduling of inspection visits at proper stages of Work completion.
- C. Regulation coordination is in addition to inspections conducted by Project Representative. Notify Project Representative of scheduled inspections involving outside regulating officials, to allow Project Representative to be present for inspections.

PART 2 - PRODUCTS (NOT USED)

PART 3 - EXECUTION (NOT USED)

END OF SECTION

**KOPACHUCK STATE PARK
DAY USE DEVELOPMENT**

SECTION 014200 – REFERENCES

PART 1 - GENERAL

1.1 DEFINITIONS

- A. General: Basic Contract definitions are included in the General Conditions of the Contract.
- B. "Approved": When used to convey Project Representative's action on Contractor's submittals, applications, and requests, "approved" is limited to Project Representative's duties and responsibilities as stated in the General Conditions of the Contract.
- C. "Directed": A command or instruction by Project Representative. Other terms including "requested," "authorized," "selected," "required," and "permitted" have the same meaning as "directed."
- D. "Indicated": Requirements expressed by graphic representations or in written form on Drawings, in Specifications, and in other Contract Documents. Other terms including "shown," "noted," "scheduled," and "specified" have the same meaning as "indicated."
- E. "Regulations": Laws, ordinances, statutes, and lawful orders issued by authorities having jurisdiction, and rules, conventions, and agreements within the construction industry that control performance of the Work.
- F. "Furnish": Supply and deliver to Project site, ready for unloading, unpacking, assembly, installation, and similar operations.
- G. "Install": Operations at Project site including unloading, temporarily storing, unpacking, assembling, erecting, placing, anchoring, applying, working to dimension, finishing, curing, protecting, cleaning, and similar operations.
- H. "Provide": Furnish and install, complete and ready for the intended use.
- I. "Project Engineer", "Project Architect", "Engineer", and "Architect" are interchangeable terms.
- J. Project Representative and Owners Representative are interchangeable terms.
- K. "As-built Drawings": Drawings done by the Contractor in the field showing changes to the Work.
- L. "Record Drawings": Drawings prepared based on the information on the As-built Drawings.

1.2 GENERAL

- A. Applicable standards of the construction industry have the same force and effect (and are made a part of the Contract Documents by reference) as if directly copied or bound herein.

**KOPACHUCK STATE PARK
DAY USE DEVELOPMENT**

1.3 PUBLICATION DATES

- A. Where compliance with an industry standard is required, comply with the standard in effect on Bid Date.

1.4 ABBREVIATIONS AND NAMES

- A. The following acronyms or abbreviations, referenced in the Contract documents, are defined to mean the associated name. Applicable standards include, but are not limited to the following:

1.	AASHTO	American Association of State Highway & Transportation Officials
2.	ACI	American Concrete Institute
3.	AGA	American Gas Association
4.	AI	Asphalt Institute
5.	AIA	American Institute of Architects (The)
6.	AISC	American Institute of Steel Construction, Inc.
7.	AISI	American Iron and Steel Institute
8.	AITC	American Institute of Timber Construction
9.	ANSI	American National Standards Institute
10.	APA	Engineered Wood Association (The)
11.	APWA	American Public Works Association
12.	ASME	American Society of Mechanical Engineers
13.	ASTM	American Society for Testing and Materials International
14.	AWPA	American Wood Protection Association
15.	AWS	American Welding Society
16.	AWWA	American Water Works Association
17.	CRSI	Concrete Reinforcing Steel Institute
18.	EPA	Environmental Protection Agency
19.	HPVA	Hardwood Plywood and Veneer Association
20.	IBC	International Building Code
21.	IEEE	Institute of Electrical & Electronics Engineers, Inc. (The)
22.	IES	Illuminating Engineering Society of North America
23.	LPI	Lighting Protection Institute
24.	MCAA	Mechanical Contractors Association of America, Inc.
25.	NIST	National Institute of Standards and Technology
26.	NCMA	National Concrete Masonry Association
27.	NEC	National Electrical Code
28.	NECA	National Electrical Contractors Association, Inc.
29.	NFPA	National Fire Protection Association
30.	NHLA	National Hardwood Lumber Association
31.	NSF	National Sanitation Foundation International
32.	OSHA	Occupational Safety & Health Administration
33.	PCA	Portland Cement Association, (The)
34.	SEPA	State Environmental Policy Act
35.	UL	Underwriters Laboratories, Inc.
36.	UPC	Uniform Plumbing Code
37.	WCLIB	West Coast Lumber Inspection Bureau (Grading Rules)
38.	WRI	Wire Reinforcement Institute
39.	WSDOE	Washington State Department of Ecology (or ECY)
40.	WSDOH	Washington State Department of Health (or DOH)

**KOPACHUCK STATE PARK
DAY USE DEVELOPMENT**

- | | | |
|-----|-------|---|
| 41. | WSDOT | Washington State Department of Transportation |
| 42. | WSPRC | Washington State Parks and Recreation Commission |
| 43. | WWPA | Western Wood Products Association (Grading Rules) |

PART 2 – PRODUCTS (NOT USED)

PART 3 – EXECUTION (NOT USED)

END OF SECTION

**KOPACHUCK STATE PARK
DAY USE DEVELOPMENT**

SECTION 015000 – TEMPORARY FACILITIES AND CONTROLS

PART 1 - GENERAL

1.1 PROTECTION OF PROPERTY AND EXISTING FACILITIES

- A. Provide protections necessary to prevent damage to park property and facilities.
- B. Only rubber-tired equipment is permitted to operate on paved park roads.
- C. Protect existing trees and other vegetation indicated to remain in place against cutting, breaking or skinning of roots, skinning and bruising of bark, or smothering of trees by stockpiling materials within dripline. Provide necessary temporary guards to protect trees and vegetation to remain in place.
- D. Make every effort to minimize damage and cutting major tree roots during excavation operations. Provide protection for larger tree roots exposed or cut during excavation operations.

1.2 ENVIRONMENTAL PROTECTIONS

- A. Scope:
 - 1. Provide labor, materials, equipment and perform Work required for protection of environment during and as a result of construction operations under contract.
- B. Applicable Regulations:
 - 1. Comply with applicable federal, state and local laws and regulations concerning environmental pollution control and abatement, and specific requirements elsewhere in specifications and drawings to prevent and provide for control of environmental pollution.
- C. Protection of Land Resources:
 - 1. Give special attention to the effect of Contractor's operations upon surroundings. Take special care to maintain natural surroundings undamaged and conduct Work in compliance with following requirements:
 - a. When Work is completed, remove storage and other Contractor buildings and facilities, and sites restored to a neat and presentable condition appropriate to surrounding landscape, unless otherwise specified. Remove debris resulting from Contractor's operation.
 - b. Store petroleum products, industrial chemicals and similar toxic or volatile materials in durable containers approved by the Authority Having Jurisdiction and located in areas where accidental spillage will not enter water. Store substantial quantities of materials in an area surrounded by containment dikes of sufficient capacity to contain an aggregate capacity of tanks.

**KOPACHUCK STATE PARK
DAY USE DEVELOPMENT**

D. Protection and Restoration of Property:

1. Preserve public and private property, monuments, power and telephone lines, other utilities, prevention of damage to natural environment, etc., insofar as they may be endangered by Work.
2. When or where any direct or indirect damage or injury is done to public or private property by or on account of any act, omission, neglect or misconduct in execution of Work, or in consequence of non-execution of Contractor, restore, or have restored at Contractor's expense, such property to a condition similar and equal to that existing before such damage or injury was done, by repairing, rebuilding, or otherwise restoring same, or make good damage or injury in some other manner acceptable to Project Representative.

E. Protection of Water Resources:

1. Perform Work not to create conditions injurious to fish or to their habitat, or which would make water unsuitable for private, municipal, or industrial use.
2. Take special measures to prevent chemicals, fuels, oils, grease, bituminous materials, waste washings, herbicides, insecticides, lime, wet concrete, cement, silt or organic or other deleterious material from entering waterways.
3. Dispose of offsite, in a lawful manner conforming to applicable local, state and federal laws wastes, effluents, trash, garbage, oil, grease, chemicals, cement, bitumen, etc., petroleum, and chemical products or wastes containing such products. Furnish Owner with documentation showing compliance with this requirement.
4. Conform to applicable local, state and federal laws for disposal of effluents. Dispose of waters used to wash down equipment in a manner to prevent their entry into a waterway. If waste material is dumped in unauthorized areas, remove material and restore area to condition of adjacent, undisturbed area. If necessary, excavate contaminated ground and disposed of as directed by Project Representative and replace with suitable compacted fill material with surface restored to original condition.

F. Dust Control:

1. Dust control is required on roads used by Contractor. Maintain excavations, embankments, stockpiles, roads, plant sites, waste areas, borrow areas and other Work areas within or without the Project boundaries free from dust which would cause a hazard or nuisance to others. Provide approved, temporary methods of stabilization consisting of sprinkling, chemical treatment, light bituminous treatment or equal methods to control dust. If sprinkling is used, sprinkling must be repeated at intervals to keep disturbed areas at least damp.

G. Temporary Water Pollution/Erosion Controls:

1. Provide for prevention, control and abatement of soil erosion and water pollution within the limits of Project, to prevent and/or minimize damage to adjacent bodies of water and Work itself.
2. Coordinate temporary soil erosion/water pollution control measures with permanent drainage and erosion control Work to ensure effective and continuous controls are maintained throughout Project life.

**KOPACHUCK STATE PARK
DAY USE DEVELOPMENT**

3. Develop a written spill prevention and response plan for construction activities adjacent to/and over any surface waters and/or wetlands. “Adjacent” means within 150’ as measured on a horizontal plane. Plan addresses:
 - a. Narrative description of the proposed construction methods, materials, and equipment to be used for Work
 - b. Assessment and listing of hazardous materials and/or potential contaminants that could be released during execution of Work
 - c. SDS sheets with cleanup instructions for potential contaminants
 - d. Spill response/cleanup materials and instructions for use
 - e. Procedures and precautions to prevent spills
 - f. Spill response training for on-site personnel, including the location of the containment and cleanup materials at site
 - g. Emergency notification in case of a spill or release. Park Manager and Project Representative must be included on the list of notified.
4. Comply with applicable codes and ordinances for spill prevention and response plan and submit a copy to Project Representative before commencing Work adjacent to or over any waters and/or wetlands.

H. Emergency Spill Response Notification

1. Under state law, Ecology must be notified when any amount of regulated waste or hazardous material that poses an imminent threat to life, health, or the environment is released to the air, land, or water, or whenever oil is spilled on land or to waters of the state. The spiller is always responsible for reporting a spill. Failure to report a spill in a timely manner may result in enforcement actions. If you are not responsible for a spill, making the initial notification does not make you liable. However, please consult with Ecology’s response team before attempting any type of response or cleanup. Also notify Park Manager and Project Representative.
2. If oil or hazardous materials are spilled to state waters, the spiller must notify both federal and state spill response agencies. The federal agency is the National Response Center at 1-800-424-8802. For state notification, call the Washington Emergency Management Division (EMD) at 1-800-258-5990 or 1-800-OILS-911 AND the appropriate Ecology regional office for your county (see numbers below). An Ecology spill responder will normally call reporting party back to gather more information. The agency will then determine its response actions. Also notify Park Manager and Project Representative.
3. Ecology Regional Spill Reporting Numbers:
 - a. Southwest Regional Office: (360) 407-6300 (Clallam, Clark, Cowlitz, Grays Harbor, Jefferson, Lewis, Mason, Pacific, Pierce, Skamania, Thurston, and Wahkiakum counties).
TDD: Washington Relay Service 711 or (800) 833-6388.

1.3 PARK TRAFFIC/PEDESTRIAN CONTROLS

- A. Properly warn the public of construction equipment and activities, open trenches, and/or other unsafe conditions by providing all necessary warning equipment. Equipment includes warning signs, barricades, fencing, flashing lights and traffic control personnel (flaggers).

**KOPACHUCK STATE PARK
DAY USE DEVELOPMENT**

- B. Conduct operations with the least possible obstruction and inconvenience to the public in accordance with appropriate Section(s) of the WSDOT "Standard Specifications".

1.4 PROTECTION OF WORK

- A. Protect Work, materials, and equipment against damage, weather conditions, or other hazards. Equipment, Work or materials found damaged or in other than new condition will be rejected by Project Representative.

1.5 REMOVAL AND REPLACEMENT OF STATE-OWNED ITEMS

- A. Should any state-owned items, such as signs, bumper blocks, or related items, interfere with the proper construction process, remove and reinstall such items to the satisfaction of Project Representative.

1.6 USE OF PARK SPACE

- A. Only in areas of park that Contract covers and only during active inclusive dates of Contract.
- B. Contractor vehicle and equipment parking only as designated by Project Representative.
- C. Contractor will be issued temporary parking passes for construction crew, vehicles and equipment, valid for the duration of the contract only.

1.7 ROADWAY CLOSURE

- A. The project area will be closed for the duration of the project. Supply necessary barricades, etc., to effectively prevent automotive traffic from entering the project site.

1.8 UTILITIES

- A. Existing subsurface utilities on Project are represented on Contract Drawings to the best of the Commission's knowledge. It is Contractor's responsibility to verify existence of utilities and determine exact location and depth. Maintain use of utilities during construction through temporary connections or other measures suitable to Commission. No extra compensation will be made for removal, temporary connections, relocations, or replacement of utilities.

1.9 SERVICE OUTAGES

- A. Coordinate and schedule outages for, power, water, and sewer service connections/repairs with Park Manager, so as not to inconvenience park staff or public.

**KOPACHUCK STATE PARK
DAY USE DEVELOPMENT**

1.10 SANITARY FACILITIES

- A. Provide temporary toilets, wash facilities, and drinking water for use of construction personnel. Comply with requirements of Authorities Having Jurisdiction for type, number, location, operation, and maintenance of fixtures and facilities.

PART 2 - PRODUCTS (NOT USED)

PART 3 - EXECUTION (NOT USED)

END OF SECTION

**KOPACHUCK STATE PARK
DAY USE DEVELOPMENT**

SECTION 015526 – TRAFFIC CONTROL

PART 1 – GENERAL

1.1 RELATED REQUIREMENTS

- A. Section 015000 – Temporary Facilities and Controls

1.2 GENERAL

- A. Provide flaggers, signs, and other traffic control devices in accordance with the Washington State Department of Transportation (WSDOT) Current Edition, Standard Specifications for Road, Bridge, and Municipal Construction and the Manual on Uniform Traffic Control Devices (MUTCD). Erect and maintain construction signs, warning signs, detour signs, and other traffic control devices necessary to warn and protect the public from injury or damage as a result of the Contractor's operations that may occur on highways, roads, drives, streets, or sidewalks and walkways. Do no work on or adjacent to the above locations until necessary signs and traffic control devices are in place.
- B. These flaggers, signs, and other traffic control devices are for the safety of the public, the Contractor's employees, and Commission's personnel and to facilitate the movement of the traveling public. They may be used for the separation or merging of public and construction traffic when in accordance with a specific approved traffic control plan.
- C. Upon failure of the Contractor to immediately provide flaggers; erect, maintain, and remove signs; or provide, erect, maintain, and remove other traffic control devices, the Commission may, without further notice to the Contractor, shut down the Contractor's activity until adjacent traffic control is implemented.
- D. Providing adequate flaggers, signs, and other traffic control devices for the protection of the work and the public at all times, regardless of whether or not the flaggers, signs, and other traffic control devices are ordered by the Project Representative, furnished by the Commission, or paid for by the Commission or by any modifications made by the Contractor. The Contractor shall be liable for injuries and damages to persons and property suffered by reason of the Contractor's operations or any negligence in connection therewith.
- E. Lane closure or diversion: advise Project Representative a minimum of two calendar days prior to implementation.

1.3 CONFORMANCE TO ESTABLISHED STANDARDS

- A. Flagging, signs, and other traffic control devices: conform to the standards established in the latest edition of the WSDOT Standard Specifications for Road, Bridge, and Municipal Construction, to the WSDOT Traffic Control Plans 1 through 18 (TC1-19) as published by WSDOT at <https://www.wsdot.wa.gov/Design/Standards/PlanSheet/Work-Zone-Typical-TCPs.htm> and to the Manual on Uniform Traffic Control Devices (MUTCD).

**KOPACHUCK STATE PARK
DAY USE DEVELOPMENT**

1.4 SUBMITTALS

- A. Submit a temporary traffic control plan for Project Representative review.

PART 2 – PRODUCTS (NOT USED)

PART 3 – EXECUTION

3.1 CONSTRUCTION PARKING CONTROL

- A. Control vehicular parking to prevent interference with public traffic and parking, and access by emergency vehicles. Monitor parking of construction personnel's vehicles. Maintain vehicular access to and through parking areas. Prevent parking on or adjacent to access roads or in non-designated areas.

END OF SECTION

KOPACHUCK STATE PARK DAY USE DEVELOPMENT

SECTION 015639 - TEMPORARY TREE AND PLANT PROTECTION

PART 1 - GENERAL

1.1 SUMMARY

- A. This Section includes the administrative and procedural requirements for the protection of trees, shrubs, and plant material not designated for removal. Trees, shrubs, and plant material not designated for removal shall be left in place and protected from damage or injury during construction using full and adequate methods of protection in order to preserve these natural resources, ecological function, and aesthetic character of the park.

1.2 REFERENCES

A. Definitions

1. Arborist Qualifications: An Arborist approved of by the Project Representative or certified by the International Society of Arboriculture (ISA) or Association of Consulting Arborists (ASCA) and licensed in the jurisdiction where project is located.
2. Critical Root Zone (CRZ): The portion of the root system nearest the stem that is critical for the stability and vitality of the tree. The minimum CRZ is a circular area having a radius of one foot for each one inch of trunk diameter defined by measuring the trunk diameter at 4.5 feet above ground level. For example, a tree that has a diameter of 20 inches would have a CRZ with a radius of 20 feet from the base of the tree. This is a MINIMUM CRZ radius for healthy trees; the CRZ often extends beyond the dripline of the tree. A critical root zone defined by 2.5 feet radius for each 1-inch diameter is desirable for old growth, historic, and character trees as designated by the Project Representative.
3. Vegetation Protection Zone (VPZ): A defined area of any size within the project area where existing vegetation (trees, shrubs, or other plant material) is to be protected from construction impacts. The zone may be accomplished by physical barriers or other means (e.g., soil protection layers or treatments).
4. Soil Protection Zone (SPZ): A defined area of any size within the project area where sensitive native soils are to be protected from construction impacts. The zone may be accomplished by physical barriers or other means (e.g., soil protection layers, durable matting, or other treatments as specified by the Project Representative).
5. High Risk Tree: Any tree with a structural defect and/or disease that makes the tree highly prone to failure, and which has a target and may result in personal injury or property damage. A high risk tree is the same as an "Emergency Tree" as defined in WAC 352-28-005 (<https://apps.leg.wa.gov/wac/default.aspx?cite=352-28-005>)

B. Reference Standards

1. ANSI A300. Specifications for Tree, Shrub, and Other Woody Plant Management including Section 5: Management of Trees and Shrubs During Site Planning, Site Development, and Construction.

**KOPACHUCK STATE PARK
DAY USE DEVELOPMENT**

2. ANSI Z133-2012. Safety Requirements for Arboricultural Operations.
3. Council of Tree and Landscape Appraisers. (2020). *Guide for Plant Appraisal*, 10th ed. International Society of Arboriculture, Champaign, Illinois.

1.3 SUBMITTALS

- A. Tree Removal and Pruning Schedule: Written schedule from project Arborist detailing scope and extent of tree removals and pruning of trees to remain that interfere with or are affected by construction.
- B. Certification: From project Arborist, certifying that trees indicated to remain have been protected during construction according to recognized standards and that trees were promptly and properly treated and repaired when damaged.
- C. Maintenance Recommendations: From project Arborist, for care and protection of trees affected by construction during and after completing the Work.

1.4 QUALITY ASSURANCE

- A. Tree Pruning Standard: Comply with ANSI A300 (Part 1), "Tree, Shrub, and Other Woody Plant Maintenance--Standard Practices (Pruning)."
- B. Construction Management Standard: Comply with ANSI A300 (Part 5): Management of Trees and Shrubs During Site Planning, Site Development, and Construction
- C. Tree Planting: Comply with ANSI A300 (Part 6) Planting and Transplanting
- D. Tree Root Protection and Management: Comply with ANSI A300 (Part 8) - 2013 Root Management Standard.

PART 2 - PRODUCTS

2.1 TREE PROTECTION MATERIALS

- A. Temporary Fencing
 1. Chain link fencing panels 6 feet tall by any length up to 14 feet. Panels must be braced and must be secured to stands and weighted per manufacturers specifications.
 2. Continuous molded safety mesh 36 inches wide with clear openings no more than 1-1/2 inches x 2 inches. Orange, 40 grams per square foot, high density polyethylene with U-V inhibitor suitable for above-grade use installed around the circumference of the CRZ.
 3. Posts five-foot steel heavy-duty "T" posts, 1-3/8 inches x 1-3/8 inches x 7/64 inches with steel anchor placed at 8' intervals at or beyond the CRZ.
 4. Nylon zip straps having a minimum breaking strength of 150 lbs.

**KOPACHUCK STATE PARK
DAY USE DEVELOPMENT**

2.2 SOIL AND ROOT PROTECTION

- A. Mulch: Ground, shredded bark, or wood and bark chips, or “hog fuel” free from deleterious materials. Or new straw mulch, free from weeds, weed seeds, and foreign materials.
- B. Landscape fabric: American Excelsior Stabilenka 140, Celanese Mirafi 140, Propex 45-45, or approved equivalent geotextile.
- C. Filter Fabric: Manufacturer’s standard, nonwoven, pervious, geotextile fabric of polypropylene, nylon, or polyester fibers.
- D. Ground staples: 9 inches x 9 inches wire staples sufficient for holding landscape fabric or filter fabric in place for required time period.
- E. Ground protection mats: Construction mats or timber mats, as a temporary road surface of sufficient weight rating for the equipment being operated in the work area.

2.3 TREE TRUNK PROTECTION

- A. Where work has been approved to take place within the CRZ, tree trunk protection shall be installed vertically around tree trunk on all sides exposed to construction activity.
- B. Common wood 2 inches x 4 inches lumber, 8 feet long, without nails, other hardware, concrete residue, or other material that may be detrimental to plant health.
- C. Strapping sufficient to hold 2 x 4’s

PART 3 - EXECUTION

3.1 PLANNING AND NOTIFICATION

- A. Where existing trees and other vegetation are in the area of work, or where existing trees outside the area of work have a CRZ extending into the area of work, employ methods to minimize adverse impact to the existing trees (including limbs, stems, and roots), understory vegetation and their root systems, and soils. Where VPZ are designated by the Project Representative and/or in project plans, observe protection measures set forth herein. Notify the Project Representative of any construction work within the CRZ of trees at least two (2) working days before the scheduled activity.

3.2 PREPARATION

- A. Prior to Construction: Erect tree and plant protection prior to beginning any site work. Protect trees to remain against cutting, breaking, skinning, or compaction of roots; skinning or bruising of bark; breaking of branches and foliage. Review locations, fencing, and other markings of any VPZ and CRZ for trees within the construction area with the Project Representative.
- B. Tree Removal: Trees that are scheduled for removal as part of the project should be removed before construction to prevent hazards during construction.

**KOPACHUCK STATE PARK
DAY USE DEVELOPMENT**

- C. Material Storage: Do not store construction materials, debris, or excavated material inside critical root zones or vegetation protection zones.
- D. Vehicle and Foot Traffic: Designate access routes within construction area and limitations on equipment and vehicles. Designate parking on existing pavement or away from critical root zones of trees. Tree protection fencing will serve as an exclusion zone within the CRZ except for where plans stipulate work will take place within the CRZ.

3.3 CRITICAL ROOT ZONE AND VEGETATION PROTECTION ZONE DESIGNATION

- A. Temporary Fencing: Install temporary fencing around CRZ, VPZ, or SPZ of either chain link or plastic mesh as indicated by Project Representative. Maintain temporary fence during construction and remove only when construction is complete.
 - 1. For plastic mesh, line posts space at eight feet maximum. Set posts vertically to minimum 18 inches depth. Posts may be driven provided method of driving does not damage posts. Ensure that posts do not damage tree roots.
 - 2. Where plastic fence is used, secure plastic fencing to posts with nylon zip-straps, minimum three per post. Draw fence material tight and vertical. Where chain link panels are used join panels with manufacturers clamps that require tool removal.
 - 3. With Project Representative's approval, sections of tree protection fencing may be removed temporarily to allow approved short-term construction activities. Reinstall fencing immediately when construction operations permit.
- B. Tree Trunk Protection: Where required tree trunks shall be protected by placing 2 x 4 lumber around the trunk, spaced so that strapping will not come in contact with the tree bark and lumber does not damage branches. Use strapping to hold lumber in place. Secure straps without nailing into or otherwise damaging tree bark.

3.4 SOIL COMPACTION, LOSS, AND DAMAGE WITHIN THE CRITICAL ROOT ZONE

- A. Protection against soil compaction within the CRZ may include but will not be limited to the following methods:
 - 1. Application of a minimum 6-inch thick layer of mulch (or wood chips salvaged from clearing and grubbing operations) within the CRZ. Replenish mulch as necessary to maintain a 6-inch depth. Do not place mulch within 6 inches of tree trunks. Where mulch is to be removed following project completion it should be underlaid with a porous geotextile.
 - 2. Ground protection mats, such as: timber or steel planking, construction mats, 1/2 inches thick CDX grade (or better) plywood, or brush for protection of surface roots and vegetation from equipment.
 - 3. Where equipment operating within the CRZ exceeds 12,000 lbs use a 6-inch layer of mulch overlaid with ground protection mats described above.
- B. Protection of soils against erosion and loss within the critical root zone of trees may require application of mulch, wood chips, ground protection mats, or landscape fabric at the request of the Project Representative.

**KOPACHUCK STATE PARK
DAY USE DEVELOPMENT**

- C. Noxious Materials: Protect soils from damage caused by runoff or spillage of noxious materials while operating, mixing, placing, or storing construction materials and equipment; this includes washout of concrete mixing vessels, dewatering operations, equipment cleanup, maintenance, and service; ponding, erosion, or excessive wetting may incur a Stop-Work order at the discretion of the Project Representative.
- 3.5 TRENCHING, DIGGING, TUNNELING, AND GRADING WITHIN THE CRITICAL ROOT ZONE:
- A. Disturbance to soils and impacts to roots within the CRZ may require any of, and will not be limited to, the following methods, practices, and restrictions:
1. Maintain existing grade within CRZ of trees unless otherwise directed.
 - a. Lowering grades (cutting): Where existing grade is above new finish grade shown around trees, carefully excavate within CRZ to new grade. Document roots exposed in this process with photographs to be shared with project Representative.
 - b. Raising grades (filling): Where existing grade is raised within the CRZ to greater than 4 inches above existing grade these roots shall be considered damaged by smothering. Methods to increase air exchange of tree roots within these areas may be required. Examples of such methods may include and will not be limited to:
 - 1) Application of a 6 inch or thicker layer of large clean aggregate (2 inches by 4 inches or larger) covered with landscape fabric below fill material to maintain large pore space.
 - 2) Selection of a fill material with high porosity and minimal compressibility, which may include mulch. Compaction will not be required except as required by structural load requirements, to limit soil compaction.
 2. Alternative excavation methods that minimize root damage may be required. These may include but are not limited to: hand digging, horizontal boring, use of an air excavation tool, or other methods as otherwise deemed necessary by the Project Representative.
- B. Only limited intrusions into tree CRZ zones will be allowed as shown on the plans and with the approval of the Project Representative. Where trenching for utilities or irrigation is required within CRZ's of trees the following may be required:
1. No cutting of roots greater than two inches diameter. Tunnel under or around roots by drilling, auger boring, air excavation, or digging by hand.
 2. Where necessary for installation, cut roots with sharp pruning instruments flush with the edge of the trench or tunnel; do not break or chop.
 3. Avoid hitting roots with heavy equipment. Roots that are ripped by equipment should be excavated by hand, photographed, kept moist with mulch or burlap layers, and inspected by the Project Representative.
 4. Pile excavated soil outside of the CRZ of residual trees and return area to original grade upon completion of work.
 5. Cover exposed roots with soil as soon as possible or at the end of each day; the soil compacted to the original firmness only; and, watered when conditions are dry.
 6. Tree root pruning or other tree root treatments may be required as directed by the Project Representative.

**KOPACHUCK STATE PARK
DAY USE DEVELOPMENT**

7. Root painting is not permitted.

3.6 STEM AND BRANCH PRUNING:

- A. Any unnecessary cutting, breaking, skinning, or bruising of bark; breaking of branches and foliage; damage or clearing of vegetation in the work area will not be permitted. Where permitted, stem and branch pruning must follow ANSI A300 Standards (including Part 1 and Part 5).
- B. Temporarily tie-up of low limbs is permitted where designated by the project representative.
- C. All final pruning cuts shall be made in branch tissue close to the trunk or parent limb, without cutting into the branch bark ridge or branch collar and without leaving a stub. Flush cuts to the tree trunk that remove the branch collar are unacceptable. Flush cuts result in a larger wound and expose trunk tissues to the possibility of decay.
- D. All significant tree pruning must have prior approval of Project Representative. An approved Arborist may be required, at the Contractors expense, for extensive or technically challenging pruning activities. Such requirements will be made explicit to the Contractor prior to the start of work.
- E. Only proper branch pruning techniques will be accepted. Improperly pruned trees could be irreparably damaged and are subject to section 3.7 DAMAGE TO TREES AND TREE REPLACEMENT.

3.7 DAMAGE TO TREES AND TREE REPLACEMENT:

- A. Should any tree or vegetation designated to remain be damaged in the course of construction activities immediately notify the Project Representative for inspection and direction for remedy.
- B. Remedies for damage will, at the Owner's discretion, require removal and disposal of the damaged tree(s) and be one of the following, at the discretion of the Project Representative.
 1. Compensate the Owner in cash or as a credit to the contract for up to the full value of the damaged tree, as appraised by an ISA certified Arborist according to the latest edition of the "Guide for Plant Appraisal".
 2. Replace each damaged tree under 6 inches diameter at breast height measurement with one replacement tree of 1-3/4 inches caliper measure. Replace each damaged tree over 6 inches diameter at breast height measurement with one replacement tree of 1-3/4 inches caliper measure for each 6 inches of diameter at breast height measure of the damaged tree. The new trees may or may not be the same species, at the discretion of the Project Representative. Select nursery stock, plant, and maintain as specified in Section 1.4 QUALITY ASSURANCE.
 3. For identified old-growth trees specified to remain, the Project Representative may be provided alternative remediation requirements from Parks Stewardship staff above and beyond requirements of 3.7.B.1 and 3.7.B.2.

**KOPACHUCK STATE PARK
DAY USE DEVELOPMENT**

- C. Notify Project Representative in any case where construction called for in the contract documents cannot be completed without damage to trees identified to remain. Approval of the Project Representative is required prior to beginning construction described in the contract documents that might damage a tree designated to remain. Any tree designated to remain which is damaged without Project Representative's written approval, even if damage is necessary to complete the work, will subject the Contractor to remedies described in section 3.7 B above.

END OF SECTION

**KOPACHUCK STATE PARK
DAY USE DEVELOPMENT**

SECTION 015713 – TEMPORARY EROSION CONTROL

PART 1 - GENERAL

1.1 RELATED DOCUMENTS

- A. Drawings and general provisions of the Contract, including General Terms and Conditions and Division 1 Specification Sections, apply to this section.
- B. Stormwater Pollution Prevention Plan previously submitted during permitting by the Owner to Pierce County.
- C. Washington Department of Ecology Construction Stormwater General Permit.

1.2 DESCRIPTION

- A. Work in this section includes, but is not limited to the following:
 - 1. Temporary erosion control structures including erecting and maintaining in good condition all catch basin fabric covers, silt fences, temporary vegetation, and other erosion control measures described in the Drawings or as required by Local, State, and Federal jurisdictional agencies.
 - 2. Implement the requirements of the Stormwater Pollution Prevention Plan (SWPPP).
 - 3. Monitor stormwater and inspect best management practices (BMP's).
 - 4. Record and report results of stormwater monitoring.
 - 5. Maintenance of all erosion control measures throughout the construction period, including monthly mowing of temporary vegetation.
 - 6. Remove erosion control measures when directed by Owner.
 - 7. Terminate the Construction Stormwater General Permit and submit written verification.

1.3 JOB CONDITIONS

- A. Construct silt fence, stabilized construction entrance, catch basin fabric covers, and other temporary erosion control measures as necessary to prevent erosion or siltation of the storm sewer or adjacent areas.

1.4 SUBMITTALS

- A. Erosion Control Plan: An erosion control plan meeting Pierce County Standards, the requirements of the Stormwater Pollution Prevention Plan (SWPPP), and the WSDOE construction Stormwater General Permit shall be submitted.
- B. The plan shall identify erosion control measures to be used by the contractor for each phase of the construction. The erosion control plan shall employ best management policies.

**KOPACHUCK STATE PARK
DAY USE DEVELOPMENT**

- C. Drawings show the minimal erosion control measures to be implemented at the commencement of construction. Provide additional measures as required by Pierce County and the Washington Department of Ecology at Contractor's expense.

PART 2 - PRODUCTS

2.1 MATERIALS: EROSION CONTROL MEASURES

- A. Filter Fabric Material: Filter material for erosion control barriers shall be Mirafi 140N, or equal.
- B. Wire Fabric: Wire fabric for erosion control fence shall be 2" x 2" mesh, 14 gauge galvanized wire.
- C. Support Posts: Support posts for erosion protection barriers shall be 2 x 4, No. 2 or better wood posts or 1-1/2 x 5/8 medium weight steel fence posts.
- D. Quarry Spalls: Quarry spalls shall meet the following requirements for grading:

SIEVE SIZE	PERCENT PASSING
6"	100
3"	40 max.
3/4"	10 max.

- E. Other materials: As needed for each selected temporary erosion control measure.

PART 3 - EXECUTION

3.1 SEQUENCE

- A. All silt fence and construction entrance shall be installed prior to clearing or grading the site.

3.2 CATCH BASINS

- A. Insert filter fabric covers between the frames and grates to minimize siltation of the storm sewer system.

3.3 SILT FENCE

- A. Construct silt fence as detailed.

3.4 CONSTRUCTION ENTRANCE

- A. Construct as detailed.

**KOPACHUCK STATE PARK
DAY USE DEVELOPMENT**

3.5 CLEAN UP

- A. Remove all erosion control measures upon successful establishment of permanent stabilization.

END OF SECTION 015713

**KOPACHUCK STATE PARK
DAY USE DEVELOPMENT**

SECTION 016000 – PRODUCT REQUIREMENTS

PART 1 - GENERAL

1.1 COMMISSION FURNISHED ITEMS

- A. The Commission furnishes no items, except for paper towel dispenser/waste receptacles, toilet tissue dispensers, soap dispensers, picnic tables, and barbeques for installation by the Contractor. Make all arrangements for and provide all materials required to accomplish the Work.

1.2 IMPLIED/INCIDENTAL MATERIALS

- A. Minor materials required for proper Project completion although not specifically mentioned or shown in Contract documents, are part of materials to be provided by Contractor as a part of Contract and are considered incidental to the total cost of Project. No additional compensation is due to the Contractor for providing such items.

1.3 QUALITY OF MATERIALS

- A. Materials are to be new, free from defects, and of quality specified in the drawings and specifications.
- B. Select and provide materials to ensure satisfactory operation and rated life in prevailing environmental conditions where installed.
- C. Same make and quality throughout the entire job, for each type. Furnish materials of latest standard design products of manufacturers regularly engaged in their production.

1.4 SPECIFIED MATERIALS

- A. Drawings and specifications generally reference only one make and model for each item of material or equipment required. This is not intended to be restrictive but indicates the standard of quality, design, and features required.
- B. Specified product is the basis of design regarding physical size, strength, and performance. Products named indicate minimum acceptable product and are "or equal" unless noted otherwise.

1.5 SUBSTITUTIONS

- A. Substitutions for Cause: Submit requests for substitution immediately on discovery of need for change, but not later than [15] fifteen days prior to time required for preparation and review of related submittals.

**KOPACHUCK STATE PARK
DAY USE DEVELOPMENT**

1. Conditions: Project Representative will consider Contractor's request for substitution when the following conditions are satisfied:
 - a. Requested substitution is consistent with Contract Documents and will produce indicated results.
 - b. Requested substitution provides sustainable design characteristics that specified product provided.
 - c. Requested substitution will not adversely affect Contractor's construction schedule.
 - d. Requested substitution has received necessary approvals of Authorities Having Jurisdiction.
 - e. Requested substitution is compatible with other portions of Work.
 - f. Requested substitution has been coordinated with other portions of Work.
 - g. Requested substitution provides specified warranty.
 - h. If requested substitution involves more than one contractor, requested substitution has been coordinated with other portions of Work, is uniform and consistent, is compatible with other products, and is acceptable to all contractors involved.
 - i. Any cost savings for the approved substitution goes to the Owner.

B. Substitutions for Convenience: Project Representative will consider requests for substitution if received within [15] fifteen days after the Notice to Proceed.

1. Conditions: Project Representative will consider Contractor's request for substitution when the following conditions are satisfied:
 - a. Requested substitution offers Owner a substantial advantage in cost, time, energy conservation, or other considerations, after deducting additional responsibilities Owner must assume. Owner's additional responsibilities may include compensation to Engineer for redesign and evaluation services, increased cost of other construction by Owner, and similar considerations.
 - b. Requested substitution does not require extensive revisions to Contract Documents.
 - c. Requested substitution is consistent with Contract Documents and will produce indicated results.
 - d. Requested substitution provides sustainable design characteristics that specified product provided.
 - e. Requested substitution will not adversely affect Contractor's construction schedule.
 - f. Requested substitution has received necessary approvals of Authorities Having Jurisdiction.
 - g. Requested substitution is compatible with other portions of Work.
 - h. Requested substitution has been coordinated with other portions of Work.
 - i. Requested substitution provides specified warranty.
 - j. If requested substitution involves more than one contractor, requested substitution has been coordinated with other portions of Work, is uniform and consistent, is compatible with other products, and is acceptable to all contractors involved.

1.6 SUBSTITUTION OF MATERIALS ("OR EQUAL")

- A. Proposed equipment to be considered "or equal" will necessitate written approval by the Engineer prior to substitution.

**KOPACHUCK STATE PARK
DAY USE DEVELOPMENT**

- B. On requests for substitution of materials clearly define and describe proposed substitute.
- C. Accompany requests by complete specifications, samples, records of performance, certified test reports, and such other information as the Engineer may request to evaluate the substitute product.
- D. Contractor is responsible for a substitute item suiting the installation requirements and for additional costs incurred as a result of substitution.
- E. Final decisions regarding quality and suitability of proposed substitutions rests solely with Engineer and will be based on information submitted.

1.7 TECHNICAL DATA

- A. Technical data and information contained herein relies entirely on tests and ratings provided by manufacturers who are solely responsible for their accuracy. Project Representative, by use of this information in no way implies that Project Representative has tested or otherwise verified the results of published manufacturer's information.

1.8 DELIVERY, STORAGE AND HANDLING

- A. Transport products by methods to avoid product damage. Only deliver products to the site that are undamaged and free from defects.
- B. Provide proper equipment and personnel to handle and transport materials/products to the Project sites safely and undamaged.
- C. Promptly inspect material to assure that products comply with Contract requirements, quantities are correct, and products are undamaged.
- D. Store and/or stockpile materials and products only in areas of park designated and approved by Project Representative prior to delivery.
- E. Arrange storage to provide easy access for inspections. Original product labels, certifications, stamps, etc. to be intact and readily visible for inspection purposes.

PART 2 - PRODUCTS (NOT USED)

PART 3 - EXECUTION (NOT USED)

END OF SECTION

**KOPACHUCK STATE PARK
DAY USE DEVELOPMENT**

SECTION 017419 - CONSTRUCTION WASTE MANAGEMENT AND DISPOSAL

PART 1 - GENERAL (NOT USED)

PART 2 - PRODUCTS (NOT USED)

PART 3 - EXECUTION

3.1 DISPOSAL OF WASTE

- A. General: Except for items or materials to be salvaged, recycled, or otherwise reused, remove waste materials from Project site and legally dispose of them in a landfill or incinerator acceptable to Authorities Having Jurisdiction.
 - 1. Except as otherwise specified, do not allow waste materials that are to be disposed of accumulate on-site.
 - 2. Remove and transport debris in a manner that will prevent spillage on adjacent surfaces and areas.
- B. Waste and debris removed from the worksite and not specified for reuse becomes the responsibility of the Contractor and disposed of off park property in areas authorized by the applicable county and/or state agencies and in accordance with current rules and regulations governing the disposal of solid waste. Disposal fees and sundry charges are paid by the Contractor and are incidental to the contract.
- C. Burning: Do not burn waste materials.
- D. Disposal: Remove waste materials from Owner's property and legally dispose of them.

END OF SECTION

**KOPACHUCK STATE PARK
DAY USE DEVELOPMENT**

SECTION 017700 – CLOSEOUT PROCEDURES

PART 1 - GENERAL

1.1 REQUIREMENTS INCLUDED

- A. Related Requirements
- B. Closeout Procedures
- C. Certification that Work is Complete
- D. Final Statement of Accounting
- E. Operation and Maintenance (O&M) Instruction Manual
- F. As-Builts
- G. Special Tools
- H. Spare Materials and Parts
- I. Certificates and Permits
- J. Certification of Required Training
- K. Warranties and Bonds
- L. Outstanding Documents
- M. Prior Occupancy
- N. Substantial Completion
- O. Damage to Facilities, Roads, Vegetation or Property
- P. Final Clean-Up
- Q. Final Inspection and Acceptance

1.2 RELATED REQUIREMENTS

- A. General Conditions: Fiscal provisions, legal submittals, and other administrative requirements.
- B. General Conditions, Article 6.07 – Substantial Completion Procedure
- C. General Conditions, Article 6.09 – Final Completion Procedure

**KOPACHUCK STATE PARK
DAY USE DEVELOPMENT**

- D. Section 015000 – Temporary Facilities and Controls

1.3 CLOSEOUT PROCEDURES

- A. Comply with procedures stated in the General Conditions, Articles 6.07 and 6.09 for issuance of Certificate of Substantial Completion and Final Completion procedure. Upon issuance of Certificate of Substantial Completion, the Contractor shall complete all punch lists within thirty (30) consecutive days from the date of Substantial Completion.
- B. Owner will occupy designated portion(s) of Project for the purpose of conduct of business, under provision(s) stated in the Certificate of Substantial Completion.

1.4 CERTIFICATION THAT WORK IS COMPLETE

- A. When Contractor considers Work has reached final completion, Contractor shall submit written certification that Contract Documents have been reviewed, Work has been inspected, and that Work is complete in accordance with the Contract Documents and is ready for Owner's Representative's inspection.

1.5 FINAL STATEMENT OF ACCOUNTING

- A. In addition to submittals required by conditions of the Contract, provide submittals required by governing authorities, and submit a final statement of accounting giving total adjusted Contract Sum, previous payments, and sum remaining due.
- B. Owner will issue a final Change Order reflecting approved adjustments to Contract Sum not previously made by Change Order.

1.6 OPERATION AND MAINTENANCE (O&M) INSTRUCTION MANUAL

- A. Final payment will be held to no more than 95 percent completion percentage until receipt of the final, hard copy O&M Instruction Manuals. Payment for Contract closeout item will be made after receipt and approval of the manuals by the Project Representative. Have O&M Instruction Manuals prepared before final payment. Lack of O&M Instruction Manuals will not be a cause for Contract extension(s).
- B. Submit one (1) complete electronic PDF copy of the O&M Instruction Manual for review by Owner's Representative prior to final acceptance. Make any corrections or revisions noted by Owner's Representative and resubmit one (1) complete, revised electronic PDF copy for final review prior to creating required final hard copy sets.
- C. Furnish three (3) complete hard copy sets of binders and one (1) Electronic PDF copy on a storage device containing the following data for each mechanical, pumping, electrical equipment, major hardware, and plumbing installation provided on this Project:
 - 1. Installation instructions
 - 2. Operating instructions (start-up and shut-down)
 - 3. Maintenance instructions, including trouble shooting guide

**KOPACHUCK STATE PARK
DAY USE DEVELOPMENT**

4. Electrical schematics
 5. Illustrated parts breakdown and code (if available)
 6. Parts list (complete)
 7. Technical manuals
 8. Provide a complete list of manufacturer's representatives sales offices, or suppliers of major parts used on this Project, including their business address and telephone number, for the Park Manager's use when maintaining/repairing the system. Major parts are defined as other than miscellaneous plumbing, wire, piping fittings, etc.
 9. List of subcontractors contact information, and specific items of work performed by them.
 10. Copies of all Warranties.
 11. Tab binders and clearly mark all information contained.
- D. Affix to walls, panels, boxes or at other locations, the following data sealed in heavy plastic:
1. Operating instructions (start-up and shut-down)
 2. Electrical schematics
- E. Operating instructions refer to designated parts of each particular installation as necessary and tag such parts with permanent markers as directed by Project Representative. This includes operational equipment.

1.7 AS-BUILTS

- A. Before final acceptance of Project, furnish Project Representative "As-BUILTS" which shows as-built locations and dimensions of major items constructed. Include locations and elevations of existing utilities encountered during excavation. Show location of pipes, manholes, buildings, structures, etc. by field measurements consisting of at least two (2) ties to permanent surface objects such as hydrants, buildings, etc.
- B. Final payment: No more than 95 percent until As-Built Drawings received. Payment made after receipt and acceptance of drawings by Project Representative. Lack of As-Built Drawings will not be a cause for contract extensions.

1.8 SPECIAL TOOLS

- A. Deliver special tools required for maintenance and adjustment of equipment to Project Representative upon completion and before final acceptance of Project.

1.9 SPARE MATERIALS AND PARTS

- A. Before final acceptance, deliver spare materials, parts and other similar items in quantities specified in each Section, in addition to that used for construction of Work, to storage locations specified by Project Representative and obtain receipt of delivery prior to final payment.

1.10 CERTIFICATES AND PERMITS

- A. Submit signed original certificates of compliance and final approval from Authorities Having Jurisdiction.

**KOPACHUCK STATE PARK
DAY USE DEVELOPMENT**

1.11 CERTIFICATION OF REQUIRED TRAINING

- A. Submit signed certification that all required training of Owner's maintenance and operating personnel has been completed.

1.12 WARRANTIES AND BONDS

- A. Manufacturer, Supplier, Subcontractor Warranties and Bonds:

- 1. Provide duplicate, notarized copies. Execute Contractor's submittals and assemble documents executed by subcontractors, suppliers, and manufacturers. Provide table of contents and assemble bound in 8-1/2 x 11 inch three-ring hard cover side binders with clear view, and durable plastic covers.
- 2. Submit material prior to final application for payment. For equipment put into use with Owner's permission during construction, submit within ten (10) days after first operation. For items of Work delayed materially beyond Date of Substantial Completion, provide updated submittal within ten (10) days after acceptance, listing date of acceptance as start of Warranty period.

- B. Warranties Longer Than One Year:

- 1. For warranties specified to extend for a longer period than one (1) year, submit a letter from each subcontractor countersigned by the Contractor covering all portions of the work incorporated in the Project under agreement between Contractor and said subcontractor for the periods of time specified, beginning from Date of Substantial Completion. Letter will be substantially as follows:

*(Owner)
(Address)*

RE: (Project)

Gentlemen:

We as Subcontractor and Contractor, do hereby warrant for a period of () year(s) from the date of substantial completion that portion of the work incorporated in the project by (sub-contractor) as described below:

*()
We will remedy at our expense any defects appearing during that period due to poor or defective materials and/or workmanship and will pay for any damage resulting from occurrence of said defects and the correction of same.*

This warranty shall not be interpreted as holding the Contractor responsible for normal wear or any deterioration of work due to abuse of the work by the Owner.

Sincerely,

Subcontractor

Contractor

**KOPACHUCK STATE PARK
DAY USE DEVELOPMENT**

- C. Provide additional copies of each Warranty for inclusion in the O&M Instruction Manuals.

1.13 OUTSTANDING DOCUMENTS

- A. Expedite and submit outstanding administrative documents including outstanding cost proposals, Change Orders, etc.

1.14 PRIOR OCCUPANCY

- A. Reference General Conditions, Article 6.08.
- B. Commission has the right to occupy completed portions of Project prior to final acceptance, and such occupation is not an acceptance of Project. Prior to occupancy, Project Representative and Contractor mutually agree to a date for prior occupancy; the area to be occupied; that occupancy is commencing within the requirements of applicable codes and ordinances; that endorsements from insurance companies, as necessary to maintain full insurance of Project regardless of prior occupancy, have been obtained; and that other necessary provisions are completed.
- C. The Project Representative will inspect areas designated for prior occupancy and issue a letter of acceptance or provide a list of deficiencies to be corrected to Contractor. Correct deficiencies prior to date of occupancy.

1.15 SUBSTANTIAL COMPLETION

- A. Reference General Conditions, Article 6.07.
- B. Notify Project Representative in writing a minimum of seven (7) days in advance of the scheduled date of completion. Project Representative will conduct a "pre-final" inspection and formulate a final punch list of Work items to be completed prior to final inspection. Project Representative will establish the date of substantial completion based on pre-final inspection findings. Following this inspection, Project Representative will either issue notice of substantial completion or advise the Contractor of deficient items which must be corrected prior to issuance of substantial completion.

1.16 DAMAGE TO FACILITIES, ROADS, VEGETATION OR PROPERTY

- A. During the course of construction, should any park facility be damaged by the Contractor's actions, operations or neglect, repair any such damages to their original condition, as acceptable to the Project Representative, at no cost to the Commission.
- B. Repair, restore or replace any park roads, vegetation or property damaged by the Contractor to the original condition at the time construction began. Repair or replace trees and vegetation indicated to remain, which has been damaged by construction operations, in a manner acceptable to the Project Representative.

**KOPACHUCK STATE PARK
DAY USE DEVELOPMENT**

1.17 FINAL CLEAN-UP

- A. Upon completion of the Work and prior to final inspection and acceptance, clean up the entire construction site and all grounds occupied by the Contractor in connection with the Work.
- B. Fine graded, rake clean and smooth all worksites and disturbed areas. Remove from the park rubbish, surplus and discarded materials, falsework, temporary structures, equipment, and debris.
- C. Leave all phases of the Project clean and ready for public use prior to final acceptance.
- D. Inspect all materials and surfaces for damage, scratches, marring, untreated ends of saw cuts, etc. and repair to original or intended condition.

1.18 FINAL INSPECTION AND ACCEPTANCE

- A. Reference General Conditions, Article 6.09.
- B. Notify Project Representative in writing when Work, including punch list items, has been completed.
- C. Project Representative will schedule and conduct a final inspection to verify that outstanding Work items are complete.
- D. Owner will establish the date of final acceptance based on the results of final inspection. Complete/correct any items identified as outstanding during final inspection prior to final acceptance of Project.

PART 2 - PRODUCTS (NOT USED)

PART 3 - EXECUTION (NOT USED)

END OF SECTION 017700

**KOPACHUCK STATE PARK
DAY USE DEVELOPMENT**

SECTION 024000 - DEMOLITION

PART 1 - GENERAL

1.1 RELATED DOCUMENTS

- A. Drawings and general provisions of the Contract, including General Conditions and Division 1 Specifications, apply to this Section.

1.2 SUMMARY

- A. This section includes demolition and removal of the following:
 - 1. Asphalt and concrete as indicated.
 - 2. Existing restroom building, septic tank and drain field.
 - 3. Miscellaneous structures as required for new construction.
- B. Materials to be salvaged and/or reused:
 - 1. Existing stones (approximately 25 each) on the side of the existing restroom shall be reused in the children's play area.
 - 2. Salvage all ecology blocks and load onto owner's trailer. Coordinate with Owner's Representative.
- C. Related work in other sections include, but is not limited to:
 - 1. Section 015639 – Temporary Tree and Plant Protection.
 - 2. Section 015713 – Temporary Erosion Control.
 - 3. Section 310000 – Earthwork.
 - 4. Section 311000 – Site Clearing.

1.3 DEFINITIONS

- A. Remove: Detach items from existing construction and legally dispose of them off-site unless indicated to be removed and salvaged or recycled.
- B. Remove and Salvage: Detach items from existing construction and deliver them to Owner's Representative.
- C. Existing to Remain: Existing items of construction that are not to be removed and that are not otherwise indicated to be removed, removed and salvaged, or recycled.

**KOPACHUCK STATE PARK
DAY USE DEVELOPMENT**

1.4 SUBMITTALS

- A. Schedule of Demolition Activities: Indicate detailed sequence of demolition and removal work, with starting and ending dates for each activity, and locations of temporary protection and means of egress.

1.5 PROJECT CONDITIONS

- A. Owner assumes no responsibility for structures to be demolished.
 - 1. Conditions existing at time of inspection for bidding purpose will be maintained by Owner as far as practical, except for removal of salvaged items by salvage contractor.

PART 2 - PRODUCTS (NOT USED)

PART 3 - EXECUTION

3.1 EXAMINATION

- A. When unanticipated mechanical, electrical, or structural elements are encountered, investigate and measure the nature and extent of the element. Promptly submit a written report to the Owner's Representative.

3.2 PREPARATION

- A. Existing Utilities: Locate, identify, disconnect, and seal or cap off utilities serving structures to be demolished.
 - 1. Arrange to shut off indicated utilities with utility companies.
 - 2. If utility services are required to be removed, relocated, or abandoned, before proceeding with demolition provide temporary utilities that bypass structures to be demolished and that maintain continuity of service to other structures.
 - 3. Cut off pipe or conduit a minimum of 2' below grade. Cap, valve, or plug and seal remaining portion of pipe or conduit after bypassing.
- B. Existing Utilities: Do not begin demolition work until utility disconnecting and sealing has been completed and verified in writing.
 - 1. Temporary Shoring: Provide and maintain interior and exterior shoring, bracing, or structural support to preserve stability and prevent unexpected movement or collapse of construction being demolished.

**KOPACHUCK STATE PARK
DAY USE DEVELOPMENT**

3.3 PROTECTION

- A. Existing Items to Remain: Protect trees indicated to remain against damage during demolition.

3.4 DEMOLITION, GENERAL

- A. General: Demolish indicated existing structures and site improvements completely. Use methods required to complete the work within limitations of governing regulations and as follows:
 - 1. Do not use cutting torches until work area is cleared of flammable materials. Maintain portable fire-suppression devices during flame-cutting operations.
 - 2. Maintain adequate ventilation when using cutting torches.
 - 3. Locate demolition equipment and remove debris and materials so as not to impose excessive loads on supporting walls, floors, or framing.
- B. Site Access and Temporary Controls: Conduct demolition and debris-removal operations to ensure minimum interference with roads, streets, walks, walkways, and other adjacent occupied and used facilities.
 - 1. Do not close or obstruct streets, walks, walkways, or other adjacent occupied or used facilities without written permission from Owner and authorities having jurisdiction. Provide alternate routes around closed or obstructed traffic ways if required by authorities having jurisdiction.
 - 2. Use water mist and other suitable methods to limit spread of dust and dirt. Comply with governing environmental-protection regulations. Do not use water when it may damage adjacent construction or create hazardous or objectionable conditions, such as ice, flooding, and pollution.

3.5 MECHANICAL DEMOLITION

- A. Equipment: Disconnect equipment at nearest fitting connection to services, complete with service valves. Remove as whole units, complete with controls.
- B. Below-Grade Construction: Demolish foundation walls and other below-grade construction.
 - 1. Remove below-grade construction including foundation walls and footings completely.
- C. Existing Utilities: Demolish existing utilities and below grade utility structures that are within area for new construction including sitework. Abandon utilities outside this area.
 - 1. Fill abandoned utility structures with satisfactory soil materials according to backfill requirements in Section 310000 – Earthwork.

3.6 EXPLOSIVE DEMOLITION

- A. Explosives: Use of explosives is not permitted.

**KOPACHUCK STATE PARK
DAY USE DEVELOPMENT**

3.7 SITE RESTORATION

- A. Below-Grade Areas: Rough grade below-grade areas ready for further excavation or new construction.

3.8 REPAIRS

- A. General: Promptly repair damage to adjacent construction caused by demolition operations.

3.9 RECYCLING DEMOLISHED MATERIALS

- A. General: Separate recyclable demolished materials from other demolished materials to the maximum extent possible. Separate recyclable materials by type.
 - 1. Provide containers or other storage method approved by Owner's Representative for controlling recyclable materials until they are removed from Project site.
 - 2. Stockpile processed materials on-site without intermixing with other materials. Place, grade, and shape stockpiles to drain surface water. Cover to prevent windblown dust.
 - 3. Stockpile materials away from demolition area. Do not store within drip line of remaining trees.
 - 4. Store components off the ground and protect from the weather.
 - 5. Transport recyclable materials off Owner's property and legally dispose of them.
- B. Recycling Incentives: Revenues, savings, rebates, tax credits, and other incentives received from recycling building demolition materials shall accrue to Contractor.

3.10 DISPOSAL OF DEMOLISHED MATERIALS

- A. General: Except for items or materials indicated to be recycled, salvaged, or otherwise indicated to remain Owner's property, remove demolished materials from Project site and legally dispose of them in an EPA-approved landfill.
 - 1. Do not allow demolished materials to accumulate on-site.
 - 2. Remove and transport debris in a manner that will prevent spillage on adjacent surfaces and areas.
- B. Burning: Do not burn demolished materials.

3.11 CLEANING

- A. Clean adjacent structures and improvements of dust, dirt, and debris caused by building demolition operations. Return adjacent areas to condition existing before demolition operations began.

END OF SECTION 024000

**KOPACHUCK STATE PARK
DAY USE DEVELOPMENT**

SECTION 031000 – CONCRETE FORMING

PART 1 GENERAL

1.1 DESCRIPTION OF WORK

- A. Work in this section includes the providing the structural support and physical barriers or forms that control the shape and location of the concrete. Also included in this section are the requirements for the removal of the forms and their support

1.2 RELATED SECTIONS

- A. The provisions and intent of the Contract, including the General Conditions, Supplementary Conditions and General Requirements, apply to the work as if specified in this section.
- B. Section 032000 – Concrete Reinforcing
- C. Section 033000 – Cast-In-Place Concrete

1.3 REFERENCES

- A. U.S. Product Standard.

1.4 SUBMITTALS

- A. Manufactures product data and installation instructions for proprietary materials including form coatings, form liner, manufactured form systems, ties and accessories.
- B. Shop drawings for fabrication and erection of formwork and shoring.

1.5 QUALITY ASSURANCE

- A. Concrete Forms
 - 1. Clean concrete forms of foreign material or other objects considered deleterious to the concrete structure or surface.
- B. Design Criteria
 - 1. Design concrete forms, to meet the requirements of the type of concrete, sequence of placing, schedule, and conditions of the Project.
 - a. For calculating the strength required of forms, 1-cubic-foot of standard weight concrete is assumed to weigh 160 pounds.

**KOPACHUCK STATE PARK
DAY USE DEVELOPMENT**

- b. Construct concrete forms of stress-gradable materials. Unless noted otherwise, the maximum allowable design deflection shall be 1/360 of the span for exposed beams or slabs and 1/270 of the span for other concrete.
- c. Provide wedges, jacks, or similar devices to ensure uniform take-up or release of the forms. Do not place wedges where they will be subject to undue bearing stress. Cribbing or stacking of blocking will not be allowed.

C. Codes and Standards:

- 1. Where provisions of pertinent codes and standards conflict with these specifications, the more stringent provisions shall govern.

PART 2 PRODUCTS

2.1 GENERAL

- A. Materials for concrete forms may be new or used. The quality of the materials, not the age or previous usage, will be the determining factor as to their suitability.

2.2 JOB-BUILT FORMS

A. Wood Forms

- 1. Framing lumber shall be of standard dimensions and of such quality as to meet the requirements of the stresses applied.
- 2. Use High Density Overlay, Plywood U.S. Product Standard PS-1, for exposed concrete forms.
- 3. The plywood shall be exterior type without splits or knotholes and sanded smooth. The face grain of the plywood shall run perpendicular to the studs or joists. Joints in surfaces of forms used on exposed surfaces shall be vertical or horizontal. Plywood shall not be less than 1/2-inch thick except where curved areas require the use of 1/4-inch thick material. When 1/4-inch thick material is used, it shall be backed with heavier material.
- 4. Shiplap, square-edged boards, or tongue-and-groove sheathing may be used for forming unexposed concrete surfaces.
- 5. Use metal, fiberglass, or other special form lining where indicated on the drawings.

B. Steel Forms

- 1. Steel forms to be fabricated at the site shall be approved by the Engineer prior to construction.

C. Miscellaneous Forms

- 1. Paper, fiberglass, micarta, asphalt-impregnated fiber and other miscellaneous form materials shall be approved prior to construction.

**KOPACHUCK STATE PARK
DAY USE DEVELOPMENT**

2.3 PREFABRICATED FORMS

- A. Prefabricated forms, whether they are part of a patented system or custom-fabricated, shall be approved by the Engineer prior to assembly.

2.4 FORM LINERS AND COATINGS

- A. Form liners for board formed concrete shall be Fraser series manufactured by US Formliner.
- B. Line, coat, or treat forms with a suitable bond-breaker to ensure their timely removal with minimum damage to the concrete. Bond-breaker material shall be non-coloring and shall not leave a film on the concrete surface that will prohibit the subsequent finishing activities required to attain the desired appearance.

2.5 FORM TIES AND ACCESSORIES

- A. Form ties shall be manufactured items with stress values published. Form ties shall have a premeasured, break-back, weakened area so that ties can be removed within 3/4-inch of the concrete surface.
- B. Tie rods for use with inserts shall be set back 1-1/2 inches from the concrete surface. Tie-rod steel shall have published stress values.
- C. Wire ties and wood spacers will not be allowed.
- D. Corner brackets, column clamps and other specialized accessories shall be utilized in accordance with the manufacturer's recommendations.

2.6 FORM REMOVAL

- A. Quick-release mechanisms, wedges, screw jacks, blocking, eccentric toggle levers, or other equipment shall be according to the approved drawings.

PART 3 EXECUTION

3.1 GENERAL

- A. Set forms to allow for structural camber plus an allowance for shrinkage and settlement. The finished concrete shall conform to the lines and grades indicated on the drawings.

3.2 FORM INSTALLATION

- A. Prior to final setting or placing of reinforcing steel, forms for exposed concrete surfaces shall be treated with a bond-breaker or parting compound. Apply the compound at a rate recommended by the manufacturer, to provide a smooth surface free of dusting action caused by the chemical reaction of the compound.

**KOPACHUCK STATE PARK
DAY USE DEVELOPMENT**

- B. Forms may be set with a slight bevel or draft for easy removal, where approved by the Engineer. Use 3/4-inch chamfer strips on exposed inside and outside corners. Forms shall be mortar tight. Standing water in the forms will not be permitted. Clean the forms immediately prior to placing of concrete.

3.3 FORM REMOVAL

- A. Do not remove or release forms without the approval of the Engineer.
- B. Forms shall remain in place, during which time the temperature shall average 50 degrees F or higher, in accordance with the time specified in the following table:

Structure Component	Standard Concrete	Early Strength Concrete
Concrete retaining walls (not yet supporting loads)	3 days	N/A

Or 80 percent of design strength if no loads are to be applied, provided that a curing compound is applied immediately. Do not apply the curing compound to a construction joint surface area between footing and column or wall or to any reinforcing steel. Wet-curing may be utilized in lieu of curing compound; however, at no time during the removal of the forms and the subsequent curing period shall the surfaces of the concrete be allowed to become dry.

- C. In areas where the surface of the concrete will be exposed to seawater do not remove the forms for a period of thirty (30) calendar days, or for a period of seven (7) days for Type III cement or longer if required by the Engineer.
- D. Do not release forms from under concrete which has been cured at a temperature under 50 degrees Fahrenheit without first determining if the concrete has gained adequate strength, without regard to the time element.

3.4 SPECIAL INSPECTIONS

- A. Periodic
 - 1. Inspect formwork for shape, location and dimensions of the concrete member being formed

END OF SECTION 031000

**KOPACHUCK STATE PARK
DAY USE DEVELOPMENT**

SECTION 032000- CONCRETE REINFORCING

PART 1 GENERAL

1.1 DESCRIPTION OF WORK

- A. Work under this section shall include all labor, materials, tools and equipment necessary for the manufacture, detail, cutting, bending, transporting, and placing concrete reinforcement and associated items in conformance with the drawings and specifications for exterior retaining walls.

1.2 RELATED SECTIONS

- A. Section 031000 – Concrete Forming
- B. Section 033000 – Cast-In-Place Concrete

1.3 REFERENCES

- A. American Concrete Institute (ACI) Manual of Concrete Practice
 - 1. ACI 315 (2004) Manual of Standard Practice for Detailing Reinforced Concrete Structures
- B. ASTM International (ASTM)
 - 1. ASTM A615 (2016) Standard Specification for Deformed & Plain Carbon-Steel Bars for Concrete Reinforcement
 - 2. ASTM A706 Specification for Weldable Deformed and Plain Low-Alloy Steel Bars for Concrete Reinforcement
- C. Washington State Department of Transportation (WSDOT)
 - 1. (2018) Standard Plans for Road, Bridge, Municipal Construction; and Amendments

1.4 SUBMITTALS

- A. Manufactures product data, specifications and installation procedures for proprietary materials and reinforcement.
- B. Steel producer's certificates of mill analysis, tensile and bend tests.
- C. Concrete reinforcement will not be delivered to the job site until receipt of shop drawings and bending diagrams approval from Engineer Certifications for Reinforcement.

**KOPACHUCK STATE PARK
DAY USE DEVELOPMENT**

- D. Shop drawings for fabrication, bending and placement
- E. Other materials required for installation.

1.5 QUALIFICATIONS OF WORKERS

- A. Provide at least one qualified person who shall be present at all times during execution of this portion of the work. The qualified person shall be thoroughly familiar with the type of materials being installed and the best methods for their installation. The qualified person shall direct all Work performed under this section.

1.6 CODES AND STANDARDS

- A. In addition to complying with all pertinent codes and regulations, concrete reinforcement work shall comply with all pertinent recommendations contained in “Manual of Standard Practice for Detailing Reinforced Concrete Structures,” publication ACI 315 of the American Concrete Institute.

1.7 QUALITY CONTROL/QUALITY ASSURANCE

- A. Prior to beginning the placement of concrete reinforcing materials, the Contractor shall furnish to the Engineer a QA/QC plan outlining how concrete reinforcing will be inspected on site.

PART 2 PRODUCTS

2.1 GENERAL

- A. All concrete reinforcement materials shall be new and free from rust and shall comply with the following reference drawings for exterior retaining walls.

2.2 REINFORCING STEEL

- A. Reinforcing steel shall be ASTM A615 deformed bar, Grade 60.
- B. Where concrete reinforcement bar is to be welded. It shall conform to ASTM A706.

2.3 OTHER MATERIALS

- A. Dowels between footing and walls or columns shall be the same grade, size and spacing as the main reinforcing unless notified otherwise.
- B. Chairs or spacers for reinforcing shall be non-ferrous or plastic coated when resting on exposed surfaces.

**KOPACHUCK STATE PARK
DAY USE DEVELOPMENT**

- C. All other materials not specifically described but required for a complete and proper installation of reinforcement, shall be selected by the Contractor, and submitted to the Engineer for review and approval.

PART 3 EXECUTION

3.1 GENERAL

- A. Prior to installation of this section, carefully inspect the installed work of other trades and verify that such work is complete to the point where this installation may properly commence.

3.2 PRODUCT HANDLING

A. Protection

1. Protect reinforcement before, during and after installation and protect the installed work and materials of other trades.
2. Store material in a manner to prevent fouling with dirt, grease and other bond-breaking coatings.
3. Use all necessary precautions to maintain identification after the bundles are broken.

B. Replacements

1. In the event of damage, approval from the Engineer shall be required for all repairs and replacements necessary at no additional cost.

3.3 REINFORCING STEEL BARS

A. Order Lists

1. Before ordering material, Contractor shall furnish all order lists and bending diagrams for approval by the Engineer; reinforcement placing drawings submitted for approval shall conform to CRSI detailing practice and ASTM A767 as applicable. Material shall not be ordered until such bending diagrams have been approved. The approval of bending diagrams by the Engineer shall in no way relieve the Contractor of responsibility for the correctness of such lists and diagrams.

B. Fabrication

1. Contractor shall bend all bars cold to the shapes indicated on the Engineer approved shop drawings. Do not field-bend bars partially embedded in concrete except as indicated on the drawings or as approved by the Engineer. Make bends and hooks in accordance with the applicable portions of the International Building Code (IBC) and ASTM A767 as applicable.

**KOPACHUCK STATE PARK
DAY USE DEVELOPMENT**

C. Marking and identification

1. All bars shall be marked so their identification can be made when the final in place inspection is made.

D. Placing and Fastening

1. Contractor shall place all steel reinforcement accurately and hold firmly in the position indicated on the drawing during the placing and setting of concrete. Reinforcement shall be placed in accordance with the Concrete Reinforcing Steel Institute (CRSI) "Manual of Standard Practice". Each reinforcing bar shall be wired to a cross bar at a maximum spacing of 24" o.c. Tie bars at all intersections, except where spacing is less than one-foot in each direction, and then tie alternate intersections. Provide all accessories necessary to support reinforcing in positions shown on the plans.
2. Contractor shall provide minimum concrete covering of reinforcement as indicated on the drawings or otherwise approved by the Engineer.
3. Contractor shall maintain the minimum distance from the forms by means of stays, blocks, ties, hangers, or other approved supports. Blocks, for holding reinforcement from contact with the forms, shall be precast mortar blocks of compressive strength no less than 3,750 psi of approved shape and dimensions, or approved metal chairs. Metal chairs which are in contact with the exterior surface of the concrete shall be plastic-coated or galvanized. Separate layers of bars by plastic chairs, by precast mortar blocks of compressive strength not less than 3,750 psi, or by other equally suitable devices. The use of pebbles, pieces of broken stone, brick, metal pipe, and wooden blocks will not be permitted. The minimum spacing between bars shall be one bar diameter or one-inch minimum, but not less than 1-1/3 times the maximum size of coarse aggregate. Place reinforcement; inspect; and obtain approval of the Engineer before placing concrete. Concrete placed in violation of this provision may be rejected and removal required, to be followed by placing of new reinforcing steel and concrete by the Contractor at no additional cost.
4. In the event of reinforcement interferences as indicated on the drawings or as otherwise required, Contractor shall immediately consult the Engineer and obtain approval of new procedure before placing concrete.
5. All dowels, anchor bolts and other hardware to be set in concrete shall be tied in place prior to placement of concrete. No wet setting, stabbing, rodding or other movement of embedded items shall be performed during placement of concrete.

E. Splicing

1. Contractor shall furnish all reinforcement in the full lengths indicated on the drawings. Splicing of bars, except when indicated on the drawings, will not be permitted without written approval of the Engineer. When approved, stagger splices as far as possible.
2. 45 diameters, 24 inches minimum.
3. Splices in continuous reinforcement as used in walls, wall footings, etc., shall have a class "B" lap (1'-6" min) and the splices in adjacent bars shall be not less than 5'-0" apart. Vertical wall bars shall be spliced at or near floor lines. Bars may be wired together at splices or laps except for top reinforcing of beams and slabs or where specifically detailed to be separated.
4. Continuous reinforcement at phase transitions construction joint shall be mechanically spliced in accordance with the drawings. Reinforcement shall not be installed into insert

**KOPACHUCK STATE PARK
DAY USE DEVELOPMENT**

until start of subsequent phase. Splice inserts and cured concrete shall be protected to prevent corrosion between phases.

5. Unless shown otherwise on drawings, Contractor shall lap all reinforcing steel as follows:
 - a. No. 6 bar and smaller shall have 46 bar diameters.
 - b. No. 7 bar through No. 9 bar shall be 86 bar diameters.

3.4 CLEANING REINFORCEMENT

- A. Steel reinforcement, at the time concrete is placed around it, shall be free from loose rust or mill scale, oil, paint and all other coatings which will destroy or reduce the bond between steel and concrete.

3.5 SPECIAL INSPECTIONS

- A. Periodic
 1. Inspect reinforcing steel and placement.

END OF SECTION 032000

**KOPACHUCK STATE PARK
DAY USE DEVELOPMENT**

SECTION 033000 – CAST-IN-PLACE CONCRETE

PART 1 - GENERAL

1.1 SECTION INCLUDES

- A. Floors and slabs on grade.
- B. Vapor retarder for below slab installation.
- C. Concrete footings and foundations.
- D. Concrete reinforcement.
- E. Joint devices associated with concrete work.
- F. Concrete curing.

1.2 RELATED REQUIREMENTS

- A. Section 079200 – Joint Sealants: Products and installation for sealants for saw cut joints and isolation joints in slabs.

1.3 REFERENCE STANDARDS

- A. ACI 211.1 – Standard Practice for Selecting Proportions for Normal, Heavyweight, and Mass Concrete; 1991 (Reapproved 2009).
- B. ACI 301 – Specifications for Structural Concrete; American Concrete Institute International; 2010 (Errata 2012).
- C. ACI 302.1R – Guide for Concrete Floor and Slab Construction; 2004 (Errata 2007).
- D. ACI 304R – Guide for Measuring, Mixing, Transporting, and Placing Concrete; American Concrete Institute International; 2000.
- E. ACI 305R – Hot Weather Concreting; American Concrete Institute International; 2010.
- F. ACI 306R – Cold Weather Concreting; 2010.
- G. ACI 308R – Guide to Curing Concrete; American Concrete Institute International; 2001 (Reapproved 2008).
- H. ACI 318 – Building Code Requirements for Structural Concrete and Commentary; American Concrete Institute International; 2011.

**KOPACHUCK STATE PARK
DAY USE DEVELOPMENT**

- I. ASTM E1643 – Standard Practice for Selection, Design, Installation and Inspection of Water Vapor Retarders Used in Contact with Earth or Granular Fill Under Concrete Slabs; 2011.
- J. ASTM E1745 – Standard Specifications for Plastic Water Vapor Retarders Used in Contact with Soil or Granular Fill under Concrete Slabs; 2011.

1.4 SUBMITTALS

- A. See Section 013000 – Submittal Procedures, for submittal procedures.
- B. Refer to Structural Notes on drawings for submittal requirements.
- C. Product Data: Submit manufacturers’ data on manufactured products showing compliance with specified requirements and installation instructions.
- D. Samples: Submit samples of underslab vapor retarder to be used.
- E. Mix Design: Submit mix design for each application. See Structural Notes on Drawings.
- F. Reinforcing Steel Shop Drawings: Include bar schedules, shapes of bent bars, spacing of bars, and locations of splices, in conformance with ACI 315-92 and 318-95.
- G. Project Record Documents: Accurately record actual locations of embedded utilities and components that will be concealed from view upon completion of concrete work.

1.5 QUALITY ASSURANCE

- A. Perform work of this section in accordance with ACI 301 and ACI 318.
- B. Follow recommendations of ACI 305R when concreting during hot weather.
- C. Follow recommendations of ACI 306R when concreting during cold weather.

PART 2 - PRODUCTS

2.1 REINFORCEMENT

- A. See General Structural Notes on Drawings.
- B. Reinforcement Accessories:
 - 1. Tie Wire: Annealed, minimum 16 gage, 0.0508 inch.
 - 2. Chairs, Bolsters, Bar Supports, Spacers: Sized and shaped for adequate support of reinforcement during concrete placement.

**KOPACHUCK STATE PARK
DAY USE DEVELOPMENT**

2.2 CONCRETE MATERIALS

- A. Per Structural Drawings.

2.3 ADMIXTURES

- A. Do not use chemicals that will result in soluble chloride ions in excess of 0.1 percent by weight of cement.
- B. Per Structural Drawings.

2.4 ACCESSORY MATERIALS

- A. Underslab Vapor Retarder: Multi-layer, fabric-, cord-, grid-, or aluminum-reinforced polyethylene or equivalent, complying with ASTM E1745, Class A; stated by manufacturer as suitable for installation in contact with soil or granular fill under concrete slabs. The use of single ply polyethylene is prohibited.
 - 1. Installation: Comply with ASTM E1643.
 - 2. Accessory Products: Vapor retarder manufacturer's recommended tape, adhesive, mastic, prefabricated boots, etc., for sealing seams and penetrations in vapor retarder.
 - 3. Manufacturers:
 - a. Henry; Moistop Ultra 15: www.henry.com.
 - b. W.R. Meadows, Inc; PERMINATOR Class A – 15 mils: www.wrmeadows.com/sle.
 - c. Substitutions: See Section 016000 – Product Requirements.
- B. Non-Shrink Cementitious Grout: Premixed compound consisting of non-metallic aggregate, cement, water reducing and plasticizing agents.

2.5 BONDING AND JOINTING PRODUCTS

- A. Slab Isolation Joint Filler: 1/2 inch thick, height equal to slab thickness, with removable top section that will form 1/2 inch deep sealant pocket after removal.
- B. Joint Filler: ASTM D 1751; Asphalt impregnated fiberboard or felt, 1/4 inch thick; tongue and groove profile.

2.6 CONCRETE MIX DESIGN

- A. See General Structural Notes for Requirements.
- B. Admixtures: Add acceptable admixtures as recommended in ACI 211.1 and at rates recommended or required by manufacturer.

**KOPACHUCK STATE PARK
DAY USE DEVELOPMENT**

PART 3 - EXECUTION

3.1 EXAMINATION

- A. Verify lines, levels and dimensions before proceeding with work of this section.

3.2 PREPARATION

- A. Verify that forms are clean and free of rust before applying release agent.
- B. Coordinate placement of embedded items with erection of concrete form work and placement of form accessories.
- C. Where new concrete is to be bonded to previously placed concrete, prepare existing surface by cleaning with steel brush and applying bonding agent in accordance with manufacturer's instructions.
- D. Interior Slabs on Grade: Install vapor retarder under interior slabs on grade. Lap joints minimum 6 inches. Seal joints, seams and penetrations watertight with manufacturer's recommended products and follow manufacturer's written instructions. Repair damaged vapor retarder before covering.

3.3 INSTALLING REINFORCEMENT AND OTHER EMBEDDED ITEMS

- A. Comply with requirements of ACI 301. Clean reinforcement of loose rust and mill scale, and accurately position, support, and secure in place to achieve not less than minimum concrete coverage required for protection.
- B. Verify that anchors, seats, plates, reinforcement and other items to be cast into concrete are accurately placed, positioned securely, and will not interfere with concrete placement.

3.4 PLACING CONCRETE

- A. Place concrete in accordance with ACI 304R, IBC 1905, and ACI 301.
- B. Place concrete for floor slabs in accordance with ACI 302.1R.
- C. Notify Architect not less than 24 hours prior to commencement of placement operations.
- D. Ensure reinforcement, inserts, embedded parts, and formed construction joint devices will not be disturbed during concrete placement.
- E. Finish floors level and flat, unless otherwise indicated, within the tolerances specified below.

3.5 SLAB JOINTING

- A. Locate joints as indicated on the drawings.

**KOPACHUCK STATE PARK
DAY USE DEVELOPMENT**

- B. Anchor joint fillers and devices to prevent movement during concrete placement.
- C. Isolation Joints: Use preformed joint filler with removable top section for joint sealant, total height equal to thickness of slab, set flush with top of slab.
- D. Saw cut joints within 24 hours after placing. Use 3/16 inch thick blade, cut into 1/4 depth of slab thickness.
- E. Screed floors and slabs on grade level, maintaining surface flatness of maximum 1/4 inch in 10 ft.

3.6 FLOOR FLATNESS AND LEVELNESS TOLERANCES

- A. Correct defects by grinding or by removal and replacement of the defective work. Areas requiring corrective work will be identified. Re-measure corrected areas by the same process.

3.7 CONCRETE FINISHING

- A. Concrete Slabs: Finish to requirements of ACI 302.1R, and as follows:
 - 1. Surfaces to Receive Thin Floor Coverings: "Steel trowel" as described in ACI 302.1R; thin floor coverings include carpeting, resilient flooring, and seamless flooring.
 - 2. Other Surfaces to Be Left Exposed: Trowel as described in ACI 302.1R minimizing burnish marks and other appearance defects.

3.8 CURING AND PROTECTION

- A. Comply with requirements of ACI 308R. Immediately after placement, protect concrete from premature drying, excessively hot or cold temperatures, and mechanical injury.
- B. Maintain concrete with minimal moisture loss at relatively constant temperature for period necessary for hydration of cement and hardening of concrete.
 - a. Normal concrete: Not less than 7 days.
 - b. High early strength concrete: Not less than 4 days.
- C. Surfaces Not in Contact with Forms:
 - a. Slabs and Floors To Receive Adhesive-Applied Flooring: Curing compounds and other surface coatings are usually considered unacceptable by flooring and adhesive manufacturers. If such materials must be used, either obtain the approval of the flooring and adhesive manufacturers prior to use or remove the surface coating after curing to flooring manufacturer's satisfaction.
 - b. Initial Curing: Start as soon as free water has disappeared and before surface is dry. Keep continuously moist for not less than three days by water ponding, water-saturated sand, water-fog spray, or saturated burlap.
 - c. Final Curing: Begin after initial curing but before surface is dry.

**KOPACHUCK STATE PARK
DAY USE DEVELOPMENT**

3.9 FIELD QUALITY CONTROL

- A. An independent testing agency will perform field quality control tests, as specified in Section 014000 - Quality Requirements.
- B. Provide free access to concrete operations at project site and cooperate with appointed firm.
- C. Tests of concrete and concrete materials may be performed at any time to ensure conformance with specified requirements.

3.10 DEFECTIVE CONCRETE

- A. Defective Concrete: Concrete not conforming to required lines, details, dimensions, tolerances or specified requirements.
- B. Repair or replacement of defective concrete will be determined by the Architect. The cost of additional testing shall be borne by Contractor when defective concrete is identified.
- C. Do not patch, fill, touch-up, repair, or replace exposed concrete except upon express direction of Architect for each individual area.

END OF SECTION 033000

**KOPACHUCK STATE PARK
DAY USE DEVELOPMENT**

SECTION 033713 – PNEUMATICALLY APPLIED CONCRETE

PART 1 – GENERAL

1.1 THE REQUIREMENTS

- A. These specifications are intended to cover the material, labor, and finishing of Pneumatically Applied Concrete (Shotcrete) applied by a dry and/or wet-mix process, including formwork, color, reinforcement, concrete materials, mixture design, placement procedures, and finishes for Boulder Structures in accordance with the contract drawings and other specifications.
- B. Any work or material which is not called for in these specifications but is shown on the contract drawings, or vice versa, shall be furnished the same as if it were both on the drawings and called for in the specifications. Also, any material which has been omitted from the drawings, but which is necessary to complete the Work shall be furnished by the Contractor at no additional cost to Owner.
- C. If the Contractor has any exceptions to these specifications, these exceptions shall be made in writing and included in the formal quotation for the Work covered by these specifications.
- D. Work that does not meet the requirements of this specification for location, finish or materials used is subject to be rejected and replaced at the Contractor's expense.
- E. Definitions
 - 1. Shotcrete: Mortar and concrete (mix as specified herein) pneumatically projected onto a surface at high velocity.
 - 2. Wet-Mix Shotcrete: Shotcrete with ingredients, including mixing water, mixed before introduction into delivery hose.
 - 3. Dry-Mix Shotcrete: Shotcrete with ingredients, excluding mixing water, mixed at delivery nozzle.
- F. The Contractor shall provide and install Pneumatically Placed Concrete with integral color and steel reinforcement as shown on the Contract Drawings. Concrete wasted or rejected shall be removed from the work site at the Contractor's expense.
- G. The Contractor shall provide shop drawings and up to three (3) mock-ups of boulder improvements for the inspection by Owner's Representative. Mock ups shall be constructed off-site and stored at the project staging area. Each mock up to demonstrate final texture and color for review and/or approval by Owner's Representative prior to construction. Each Mock-up to consist of no less than the physical area of 4' long x 3' wide x 2' high and consist of a finished surface of concrete no less than 8" thick. Mockups shall be available for Owner's Representative, Landscape Architect, and Contractor reference during construction and be removed from the project site at the end of the project unless otherwise directed by the Owner's Representative.
- H. The Contractor shall meet or exceed the Installer Qualifications as listed herein.

**KOPACHUCK STATE PARK
DAY USE DEVELOPMENT**

1.2 RELATED SECTIONS

- A. Section 321313 – Cast in Place Concrete

1.3 CONTINGENT PAYMENT

- A. Payment will not be made for any material or equipment delivered to the job site for which the Contractor has not provided the required submittals or has not obtained Owner's Representative's approval of required submittals.

1.4 REFERENCES

- A. The following publications form a part of this specification to the extent referenced. The version shall be the latest version available at the time of award of contract.

1. American Concrete Institute (ACI):
 - ACI 117 Standard Specifications for Tolerances for Concrete Construction and Materials
 - ACI 211.1 Standard Practice for Selecting Proportions for Normal, Heavyweight, or Mass Concrete
 - ACI 211.5R Guide for Submittal of Concrete Proportions
 - ACI 301 Standard Specifications for Structural Concrete
 - ACI 304R Guide for Measuring, Mixing, Transporting, and Placing Concrete
 - ACI 304.2R Placing Concrete by Pumping Methods
 - ACI 305R Hot Weather Concreting
 - ACI 306R Cold Weather Concreting
 - ACI 309R Guide for Consolidation of Concrete
 - ACI 315 Details and Detailing of Concrete Reinforcement
 - ACI 318 Building Code Requirements for Reinforced Concrete
 - ACI 347 Formwork for Concrete
 - ACI 506.2 Specification for Shotcrete
 - ACI 546.2R Guide to Underwater Repair of Concrete

2. American Society for Testing and Materials (ASTM):
 - ASTM A 615 Standard Specification for Deformed and Plain Billet-Steel Bars for Concrete Reinforcement
 - ASTM C 29 Standard Test Method for Bulk Density ("Unit Weight") and Voids in Aggregate
 - ASTM C 33 Standard Specification for Concrete Aggregate
 - ASTM C 39 Standard Test Method for Compressive strength of Cylindrical Concrete Specimens
 - ASTM C 94 Standard Specification for Ready-Mixed Concrete
 - ASTM C 138 Standard Test Method for Unit Weight, Yield, and Air Content (Gravimetric) of Concrete
 - ASTM C 143 Standard Test Method for Slump of Hydraulic Cement Concrete
 - ASTM C 150 Standard Specification for Portland Cement
 - ASTM C 172 Standard Practice for Sampling Freshly Mixed Concrete

**KOPACHUCK STATE PARK
DAY USE DEVELOPMENT**

ASTM C 231	Standard Test Method for Air Content of Freshly Mixed Concrete by the Pressure Method
ASTM C 260	Standard Specification for Air-Entraining Admixtures for Concrete
ASTM C 309	Standard Specification for Liquid Membrane-Forming Compounds for Curing Concrete
ASTM C 494	Standard Specification for Chemical Admixtures for Concrete
ASTM C 618	Standard Specification for Coal Fly Ash and Raw or Calcined natural Pozzolan for Use as a Mineral Admixture in Concrete
ASTM C 1064	Standard Test Method for Temperature of Freshly Mixed Portland Cement Concrete
ASTM C 1116-10a	Standard Specification for Fiber Reinforced Concrete
ASTM C 1436	Standard Specification for Materials for Shotcrete

3. U.S. Department of Commerce, National Institute of Standards and Technology (NIST): PS 1 – Product Standard for Construction and Industrial Plywood.

- a. U.S. Department of Interior:

4. Concrete Manual, Chapter 4, 8th Edition. Specification M-47 (MO470000.296). Standard Specification for Repair of Concrete, February 1996.

B. In the event of a conflict between these Specifications and the Codes and Standards listed above, the Contractor shall bring the conflict to the attention of the Owner's Representative for written resolution.

1.5 SUBMITTALS

A. The Contractor shall submit as defined in Section 013300- Submittal Procedures

B. The Contractor shall submit the following to the Owner's Representative:

1. Work Plan and Preliminary Project Construction Schedule

- a. Means and Methods of Construction including sequencing and scheduling, temporary structures, equipment utilized, outline for proposed methods of de-watering, outline for proposed methods of placing, curing, cleanup, and protecting concrete, and contingency procedures if an unforeseen delay occurs.
 - b. List of and description of all equipment to be utilized on site.

2. Data:

- a. Concrete supplier's ready mix plant information, including plant certification.
 - b. Manufacturer's data, certificates of compliance, mill test reports and sources for cement, pozzolan, admixtures, and aggregates; manufactured materials including reinforcement and forming accessories, and integral color(s).
 - c. Design mixes for each shotcrete mix. Concrete mixture proportions in accordance with ACI 211.5 R and ACI 301.
 - d. Material Certificates: For each material item, signed by manufacturers.

**KOPACHUCK STATE PARK
DAY USE DEVELOPMENT**

- e. Quantity and size of reinforcing bars anticipated for the completion of this project.
- 3. Mock Ups:
 - a. Boulder mock ups to resemble the finished product and will be used as a reference for the level of aesthetic finishing.
 - 1) Aesthetic finishes to be selected by Owner's Representative.
 - b. Boulder mock ups shall be constructed and/or removed at the request of the Owner's Representative. The Owner's Representative shall have the right to reject any mock up for any reason.
 - c. Boulders shall be integral colored and stained to match the Bandera Granite as selected by the Owner's Representative/Landscape Architect.
- 4. Contractor to provide shop drawings for construction of faux rock elements.
- 5. Qualification Data: As described in the Quality Assurance section of this specification.
- 6. Material Test Reports: For concrete materials.
- 7. Field quality-control test reports
- 8. Substitutions and/or deviations from the plans and specifications.

1.6 QUALITY ASSURANCE

- A. Contractor shall implement procedures to assure that items and services, including subcontracted items and services, comply with this specification. These procedures will be subject to review by the Owner's Representative. Contractor shall retain services of an independent testing laboratory for performing quality control testing. The testing laboratory retained by Contractor shall meet the requirements of ASTM C 1077 – Practice for Laboratory Testing Concrete and Concrete Aggregates for use in Construction and Criteria for Laboratory Evaluation.
- B. The Contractor shall be responsible for routine quality control of concrete and its ingredients. The cost of laboratory tests on concrete field samples will be borne by the Contractor. All costs associated with additional tests, investigations, reviews, studies, etc on Work not meeting the specifications shall be sole responsibility of the Contractor.
- C. Qualifications of the Contractor and Superintendent shall meet or exceed the qualifications as specified.
 - 1. Qualifications of Artists/Finishers: Provide artists/finishers skilled in the simulation of natural formation of rock to supervise and perform the application of all work. Submit resume including all projects the Artists/Finishers have worked on, photos and detailed descriptions of the work, his/her role, the date of the project, and project Owner's current contact information. Qualifications of Artists/Finishers to be submitted with the bid proposal.
 - 2. Dry Mix Nozzleman: Certified as required by ACI 506.3R with a minimum of 3000 hours of dry mix installation and able to demonstrate by test his abilities to apply shotcrete as required by the specifications. Submit resume including all projects the Nozzleman has worked on, photos and detailed descriptions of the work, his/her role, the date of the project, and project Owner's current contact information. Qualifications of Dry Mix Nozzleman to be submitted with the bid proposal.

**KOPACHUCK STATE PARK
DAY USE DEVELOPMENT**

3. Wet Mix Nozzleman: Certified as required by ACI 506.3R with a minimum of 3000 hours of wet mix installation and able to demonstrate by test his abilities to apply shotcrete as required by the specifications. Submit resume including all projects the Nozzleman has worked on, photos and detailed descriptions of the work, his/her role, the date of the project, and project Owner's current contact information. Qualifications of Wet Mix Nozzleman to be submitted with the bid proposal.

- D. Testing Agency Qualifications: An independent agency qualified according to ASTM C 1077 and ASTM E 329 for testing indicated.

- E. Preinstallation Conference: Conduct conference at Project site to comply with requirements in Division 1 General Requirements.

- F. Comply with provisions of the following, unless more stringent requirements are indicated:
 1. ACI 301, "Specifications for Structural Concrete."
 2. ACI 506.2, "Specification for Shotcrete"

- G. It is intended that the finished products of work in this section simulate natural Bandera Granite boulders as selected by Owner's Representative/Landscape Architect.
 1. To achieve these simulations the Contractor will coordinate and cooperate fully with Owner's Representative.
 2. The Owner's Representative explicitly reserves the right to monitor the work for aesthetic quality and to assume control of the work through direction of the Contractor's project superintendent until specified effects are achieved.

- H. Temperature: ASTM C 1064/C 1064M; 1 test hourly when air temperature is 40 deg F and below and when 80 deg F and above, and 1 test for each set of compressive-strength specimens.

- I. Core Grade: Apply concrete to achieve mean core grades not exceeding 2.5 according to ACI 506.2, with no single core grade exceeding 3.0.

- J. Prepare 3 test cylinders for each mix and for each workday. Test cylinders for compressive strength according to ACI 506.2 and ASTM C 42.

- K. Field samples for testing of concrete strength and shrinkage (slump) shall be made by the testing laboratory in accordance with ASTM C172. Contractor shall furnish sample concrete, assist and provide facilities, equipment, tools and etc as needed for the testing laboratory in making and curing test cylinders and other samples and shall furnish suitable boxes for storage of compressive strength cylinders, during the initial curing period. The testing laboratory shall test the cylinders and other samples. The compression test specimens for concrete shall be made in accordance with the requirements of Section 9.2 of ASTM C 31 – Practices for Making and Curing Concrete Test Specimens in the Field and shall be 6-inch diameter and 12-inch high cylinders. Compression tests shall be performed in accordance with the requirements of ASTM C 39 – Test Method for Compressive Strength of Cylindrical Concrete Specimens.

**KOPACHUCK STATE PARK
DAY USE DEVELOPMENT**

- L. Evaluation and Acceptance of Concrete compressive strength shall be in accordance with the requirements of ACI – Building Code Requirements for Reinforced Concrete, Chapter 5 - Concrete Quality. The statistical analysis of compression tests shall be performed in accordance with ACI 214 – Recommended Practice for Evaluation of Strength Test Methods. The standard deviation of the test results shall not exceed 640 psi, when ordered at equivalent water content as estimated by slump. If any concrete fails to meet these requirements, immediate corrective action shall be taken to increase the compressive strength for all subsequent batches of the type of concrete affected. When the standard deviation of the test results exceeds 640 psi, the average strength for which the mix is designed, shall be increased by an amount necessary to satisfy the statistical requirement that the probability of any test being below the required compressive strength is 1 in 100. The required average strength shall be calculated using the actual standard deviation in accordance with Criterion No. 3 of ACI 214.
- M. All concrete, which fails to meet the requirements specified herein and ACI shall be subject to removal and replacement with no additional cost to Owner and without extension of construction schedule.

PART 2 – PRODUCTS

2.1 SHOTCRETE MIX

- A. Portland Cement shall be ASTM C150 Type I or II. Use only one brand and type of cement for Project.
- B. Fly Ash: ASTM C618, Class C or F.
- C. Prepare design mixes for each type and strength of shotcrete.
 - 1. Limit use of fly ash to not exceed, in combination, 15 percent of Portland cement by weight.
- D. Limit water-soluble chloride ions to maximum percentage by weight of cement or cementitious materials permitted by ACI 301.
- E. Water: Potable, complying with ASTM C 94/C 94M. Water used for mixing of concrete, or for processing concrete aggregates, and curing shall be clean and free from injurious amounts of acid, alkali, salts, oil, sediment or organic matter. Agricultural water with high total dissolved solids, 1000 mg/l shall not be permitted.
- F. Design-Mix Adjustments: Subject to compliance with requirements, shotcrete design-mix adjustments may be proposed when characteristics of materials, project conditions, weather, test results, or other circumstances warrant.
- G. Proportion dry mixtures by field test data methods and wet mixtures according to ACI 211.1 and ACI 301, using materials to be used on Project, to provide shotcrete with the following properties:

**KOPACHUCK STATE PARK
DAY USE DEVELOPMENT**

Table 1 – Concrete Mix

Item:	Wet Mix:	Dry Mix:
28 day compressive strength:	5,000 psi	6,000 psi
Maximum allowed slump:	2"	2"
Maximum aggregate size:	3/8"	3/8"
Minimum silica fume:	68 lb/cyd	80 lb/cyd
Waterproofing:	6 lb/cyd	6 lb/cyd
Synthetic Fibers:	6 lb/cyd	6 lb/cyd
Total cement:	590-675 lb/cyd	590-675 lb/cyd
Maximum water to cement ratio:	.4	.4
Air entrainment:	6% +- 1%	6% +- 1%

Notes:

1. The design above represents the finished product and additional quantities must be included to account for losses during application.
2. Water reducers, retarders, super plasticizers as required.
3. Reduce accelerators in dry mix as much as possible.
4. A minimum of 40 revolutions at mixing speed is required for wet mixes in order to best distribute fibers.
5. Mix designs that vary from the table above must be approved by the Owner's Representative and engineer.
6. Super absorbent polymers shall be provided to reduce cracking in mass concrete applications.

H. Admixtures: When included in shotcrete design mixes, use admixtures and retarding admixtures according to manufacturer's written instructions and per plan.

2.2 AGGREGATE

A. Aggregates shall be produced only from acceptable sources determined by tests performed to establish that concrete of required quality can be made from the sources proposed. Aggregate source shall be acceptable to Owner's Representative.

B. Concrete aggregates shall conform to ASTM C33 – Concrete Aggregates. Coarse aggregate shall be clean, hard, durable gravel, crushed gravel, crushed rock, or combination. Fine aggregate shall be hard and durable natural sand or combination of natural and manufactured sand and shall be tested in accordance with ASTM D 2419, the sand equivalency shall not be less than 70 % for an individual sample nor less than 75 % for an average of three samples. The fineness modulus of sand used shall not be less than 3.1, when tested in accordance with ASTM C 136. Lightweight sand for fine aggregate shall not be permitted. The combined aggregate shall be well graded, to produce optimum workability and consolidation characteristics. Submit final gradation to be used for review and approval by Owner's Representative. Concrete aggregate tests shall meet the following requirements:

1. The ratio of silica released to reduction in alkalinity shall not exceed 1.
2. The coarse aggregate loss shall not exceed 42 % after 500 revolutions or 10.5 % after 100 revolutions.

**KOPACHUCK STATE PARK
DAY USE DEVELOPMENT**

C. Normal-Weight Aggregates: ASTM C 33, from a single source, and as follows:

1. Aggregate Gradation: ACI 506R, Gradation No. 1 with 100 percent passing 3/8-inch sieve.

2.3 REINFORCING MATERIALS

A. Steel reinforcement shall be provided as detailed in the drawings and as called for in the reinforcing schedule.

1. Welded Wire Mesh: Square intercrimp weave wire mesh, galvanized, 1" sq openings, 0.120" diameter
2. Deformed bars: ASTM A615/A 615M Grade 60. No. 3 bars may be Grade 40.

B. Reinforcing steel shall be delivered, stored, handled in a manner to protect it from corrosion, deformation, and other damage.

C. Before placing concrete, reinforcement shall be cleaned of loose rust and other substances which would impair bonding with concrete. Rust shall be removed by wire brushing, sand blasting, or other mechanical means.

D. No painting of bars shall be permitted for marking or other purposes.

E. Supports: Bolsters, chairs, spacers, ties, and other devices for spacing, supporting, and fastening reinforcing steel in place according to CRSI's "Manual of Standard Practice" and as follows:

1. For uncoated reinforcement, use all-plastic or CRSI Class 1, plastic-protected bar supports.

F. Fiber Reinforcing: ASTM C1116/C1116M Standard Specification for Fiber-Reinforced Concrete.

1. Approved Products:
 - a. Forta-Ferro
 - b. Other as approved by Owner's Representative
2. Minimum Length: 2.00 inches
3. Minimum Tensile Strength: 90 ksi.

2.4 CONCRETE FORMS

A. Concrete forms and their erection shall meet the requirements of ACI 301. Forms shall be of suitable material and of type, size, shape, quality and strength to support shotcrete and construction loads and to enable construction as designed. The responsibility for their adequacy shall rest with the Contractor.

1. All dirt, chips, sawdust, nails and other foreign matter shall be completely removed from forms before any concrete is placed.

**KOPACHUCK STATE PARK
DAY USE DEVELOPMENT**

2. Forms to be re-used shall be thoroughly cleaned of all dirt, mortar, and foreign matter before being re-used forms to be re-used will be subject to approval by the Owner's Representative.

2.5 CHEMICAL ADMIXTURES

- A. General: ASTM C 1141, Class A or B, but limited to the following admixture materials. Provide admixtures for shotcrete that contains not more than 0.1 percent chloride ions. Certify compatibility of admixtures with each other and with other cementitious materials.
 1. Water-Reducing Admixture: ASTM C 494/C 494 M, Type A.
 2. Water-Reducing and Retarding Admixture: ASTM C 494/C 494M, Type D.
 3. Water-Reducing and Accelerating Admixture: ASTM C 494/C 494M, Type E.
 4. High-Range, Water-Reducing Admixture: ASTM C 494/C 494M, Type F.
 5. Accelerating Admixture: ASTM C 494/C494M, Type C.
- B. Air Entraining: Conforming to ASTM C 260.
- C. Silica Fume: Dry, densified dry, or slurry. Mix in accordance with ASTM C94.
- D. Waterproofing: Xypex C-1000 waterproofing or approved equal.
- E. Super plasticizers: Per ASTM C494, Type F or G.
 1. A synthesized sulfonated complex polymer type super plasticizer containing no chloride or other corrosive chemicals, or alkaline.
 2. Add to concrete mix at manufacturer's recommended dosage to allow placement with the concrete temperatures up to 90 degrees F.
 3. Provide performance on project by trial mixes or reduce temperature to below 80 degrees F by other means.

2.6 CONCRETE DYE or COLORING AGENTS

- A. All concrete shall be integral color and stained as described.
- B. Dye or other coloring admixtures complying with ASTM C 494 and C 979 shall be added to the concrete used for the boulders. Color shall simulate Bandera Granite. Contractor to submit integral color for review and approval by Owner's Representative:
 1. Approved Manufacturers:
 - a. Davis
 - b. Solomon
 - c. Submit Stain(s) to Owner's Representative for approval.
- C. Contractor shall submit for Owner's Representative approval samples of the integral and stain coloring agents proposed to be used, including name of manufacturer and photo samples of similar construction.

**KOPACHUCK STATE PARK
DAY USE DEVELOPMENT**

- D. Coloring agents shall be proportioned and mixed in accordance with the manufacturer's written instructions.

2.7 CURING MATERIALS

- A. Absorptive Cover: AASHTO M 182, Class 2, burlap cloth made from Jute or Kenaf, weighing approximately 9.0 oz./sq. yd. dry.
- B. Moisture-Retaining Cover: ASTM C 171, polyethylene film or white burlap-polyethylene sheet.
- C. Water: Potable

2.8 REPAIR MATERIALS

- A. Concrete Patching Mortar: Chemical treatment for waterproofing concrete.
- B. Xypex Concrete Waterproofing by Crystallization, Xypex Chemical Corporation.

2.9 SHOTCRETE EQUIPMENT

- A. Mixing Equipment: Capable of thoroughly mixing shotcrete materials in sufficient quantities to maintain continuous placement.
- B. Dry-Mix Delivery Equipment: Capable of discharging aggregate-cement mixture into delivery hose under close control and maintaining continuous stream of uniformly mixed materials at required velocity to discharge nozzle. Equip discharge nozzle with manually operated water-injection system for directing even distribution of water to aggregate-cement mixture.
 - 1. Provide uniform, steady supply of clean, compressed air to maintain constant nozzle velocity while simultaneously operating blow pipe for cleaning away rebound.
 - 2. Provide water supply with uniform pressure at discharge nozzle to ensure uniform mixing with aggregate-cement mix. Provide water pump to system if line water pressure is inadequate.
- C. Wet-mix Delivery Equipment: Capable of discharging aggregate-cement-water mixture accurately, uniformly, and continuously.

2.10 BATCHING AND MIXING

- A. Dry-Mix Process: Measure Mix proportions by weight batching according to ASTM C 94/C 94M or by volume batching complying with ASTM C 685/C 685M requirements.
 - 1. In volume batching, adjust fine-aggregate volume for bulking. Test fine-aggregate moisture content at least once daily to determine extent of bulking.
 - 2. Prepackaged shotcrete materials may be used at Contractor's option. Predampen prepackaged shotcrete materials and mix before use.

**KOPACHUCK STATE PARK
DAY USE DEVELOPMENT**

- B. Wet-Mix Process: Measure, batch, mix, and deliver shotcrete according to ASTM C 94/C 94M and furnish batch ticket information.
 - 1. Comply with ASTM C 685/C 685M when shotcrete ingredients are delivered dry and proportioned and mixed on-site.

PART 3 – EXECUTION

3.1 SURFACE PREPARATION

A. General

- 1. The Contractor will mark or outline the location of each boulder formation (top, crest, and toe) and obtain Owner's Representative approval before construction.
- 2. All foundation surfaces upon or against which concrete will be placed shall be prepared by suitably shaping, removing loose material, thoroughly cleaning, washing, dewatering and drying.
- 3. Surface preparation shall be performed immediately before placement of concrete.
- 4. No concrete shall be placed until all surfaces are inspected and accepted by the Owner's Representative.

B. Preparation of Earth Surfaces

- 1. All earth surfaces upon which or against which concrete is to be placed shall be well compacted and free from standing water, mud, or debris.

C. Preparation of Concrete Surfaces

- 1. The preparation of new concrete surfaces upon which additional concrete is to be placed shall consist of scarifying and cleaning while the concrete is between its initial and final set. Surface preparation for existing concrete upon which new concrete is to be placed, shall consist of removing loose material, scarifying, cleaning, installing new reinforcement as specified and shown, washing thoroughly and drying with appropriate method(s) prior to new concrete placement.
- 2. Moisten surfaces prior to placing concrete.

3.2 MIXING AND TRANSPORTING

- A. All wet mix shotcrete shall be placed within 60 minutes after the addition of water to the cement and aggregate, provided that the concrete has been continuously agitated for this period of time. Discharge of the concrete shall be completed within this time limit unless Owner's Representative requires or approves in writing, a deferent time limit, due to hot weather or other conditions.

**KOPACHUCK STATE PARK
DAY USE DEVELOPMENT**

- B. Concrete that has been transported or mixed for more than 90 minutes and has not been incorporated into the work shall not be used and shall be removed from the work site as the Contractor's property.

3.3 PLACING CONCRETE

- A. Placing concrete shall comply with the following requirements:

- 1. All concrete shall be placed in accordance with the requirements of ACI 506.2.
- 2. The Owner's Representative shall be notified not less than 24 hours in advance of concrete placement. Unless inspection is waived in each case, placing of concrete shall be performed only in the presence of the Owner's Representative.
- 3. Concrete shall not be placed until all formwork, embedded parts, steel reinforcement, foundation surfaces, and joints involved in the placing have been approved, and acceptable to the Owner's Representative. The embedded metals shall be so positioned and supported prior to placement of concrete that there shall be a minimum of 4 inches of clearance between the embedded item and surrounding concrete reinforcement. To avoid corrosion, securing the embedded items in position by wiring or welding them to reinforcement shall not be permitted, unless otherwise approved by Owner's Representative in writing. Surfaces of embedded metals shall be thoroughly cleaned of rust, dirt, grease, etc prior to installation. Anchor bolts shall be accurately set and maintained in position by templates while being embedded in concrete.

- B. Steel Reinforcement

- 1. Comply with CRSI's "Manual of Standard Practice" for fabricating, placing, and supporting reinforcement.
- 2. Clean reinforcement of loose rust and mill scale, earth, ice, and other materials that weaken shotcrete bonding.
- 3. Securely embed reinforcing anchors into existing substrates, located as required.
- 4. Accurately position, support, and rigidly secure reinforcement against displacement by formwork, construction, or shotcreting. Locate and support reinforcement by metal chairs, runners, bolsters, spacers, and hangers, as required.
- 5. Place reinforcement to obtain minimum coverage for shotcrete protection. Arrange, space, and securely tie bar supports to hold reinforcement in position during shotcreting. Set wire ties with ends directed into shotcrete, not toward exposed shotcrete surfaces.

- C. Forms

- 1. Design, erect, support, brace, and maintain forms, according to ACI 301, to support shotcrete and construction loads and to facilitate shotcreting. Construct forms so shotcrete members and structures are secured to prevent excessive vibration or deflection during shotcreting.
 - a. Fabricate forms to be readily removable without impact, shock, or damage to shotcrete surfaces and adjacent materials.

**KOPACHUCK STATE PARK
DAY USE DEVELOPMENT**

- b. Construct forms to required sizes, shapes, lines, and dimensions using ground wires and depth gauges to obtain accurate alignment, location, and grades in finished structures. Construct forms to prevent mortar leakage but permit escape of air and rebound during shotcreting. Provide for openings, offsets, blocking, screeds, anchorages, inserts, and other features required within the Work.
- 2. Form openings, chases, recesses, bulkheads, keyways, and screeds in formwork. Determine sizes and locations from trades providing such items. Accurately place and securely support items built into forms.
- D. Moisten wood forms immediately before placing shotcrete where form coatings are not used.
- E. Apply temporary protective coverings and protect adjacent surfaces against deposit of rebound and overspray or impact from nozzle stream.
- F. Apply wet-mix shotcrete materials within 90 minutes after batching.
- G. Deposit shotcrete continuously in multiple passes, to required thickness, without cold joints and laminations developing. Place shotcrete with nozzle held perpendicular to receiving surface. Begin shotcreting in corners and recesses.
- H. Remove and dispose of rebound and overspray materials during shotcreting to maintain clean surfaces and to prevent rebound entrapment.
- I. Maintain reinforcement in position during shotcreting. Place shotcrete to completely encase reinforcement and other embedded items. Maintain steel reinforcement free of overspray and prevent buildup against front face during shotcreting.
- J. Do not place subsequent lifts until previous lift of shotcrete is capable of supporting new shotcrete.
- K. Do not permit shotcrete to sag, slough, or dislodge.
- L. Placement of concrete shall be done in a manner to avoid formation of aggregate pockets or mortar poundage in corners and against forms.
- M. Placing concrete through the reinforcing steel shall be done in a manner not to cause segregation of the coarse aggregate.
- N. Concrete shall be finished in an aesthetic manner consistent with adjacent existing surface texture, approved mock ups, and to the satisfaction of the Owner's Representative.
- O. Concrete found non-conforming to the specifications before or during placement shall be removed from the work. Concrete, which is not placed in accordance with the specifications or is of inferior quality, shall be removed and replaced, at Contractor's expense.
- P. Remove hardened overspray, rebound, and laitance from shotcrete surfaces to receive additional layers of shotcrete; dampen surfaces before shotcreting.
- Q. Do not disturb shotcrete surfaces before beginning finishing operations.

**KOPACHUCK STATE PARK
DAY USE DEVELOPMENT**

R. Form Removal:

1. Forms not supporting weight of shotcrete may be removed after curing at not less than 50 deg F for 24 consecutive hours after gunning, provided shotcrete is hard enough not to be damaged by form-removal operations and provided curing and protecting operations are maintained.
 - a. Leave forms supporting weight of shotcrete in place until shotcrete has attained design compressive strength. Determine compressive strength of in-place shotcrete by testing Representative field-cured specimens of shotcrete.
 - b. Remove forms only if shores have been arranged to permit removal of forms without loosening or disturbing shores.
2. Clean and repair surfaces of forms to be reused in the Work. Split, frayed, delaminated, or otherwise damaged form-facing materials are unacceptable for exposed surfaces. Apply new form-coating compound as specified for new formwork.

- S. Remove and dispose of rebound and overspray materials from final shotcrete surfaces and areas not intended for shotcrete placement in a legal manner.

3.4 TOLERANCES FOR PLACING CONCRETE

A. All concrete placement work shall conform to the following tolerances:

1. Maximum departures from established alignment shall be limited to 0.17-feet.

3.5 UNFAVORABLE WEATHER CONDITIONS

A. General

1. When concrete is to be placed under unfavorable weather conditions special provisions shall be made in the handling and placing methods and in the protection provided during the curing period to ensure that workable concrete of full strength and specified characteristics will be obtained in the forms. Concrete shall not be placed during rain, sleet, or snow unless adequate protection is provided. The Contractor shall develop plans and procedures for protecting concrete well in advance, and equipment and material necessary for such protection shall be available at the jobsite prior to concrete placement.

B. Cold-Weather Shotcreting: Protect shotcrete work from physical damage or reduced strength caused by frost, freezing, or low temperatures according to ACI 306.1 as follows:

1. Discontinue shotcreting when ambient temperature is 40 deg F and falling.
2. Uniformly heat water and aggregates before mixing to obtain a shotcrete shooting temperature of not less than 50 deg F and not more than 90 deg F.
3. Do not use frozen materials or materials containing ice or snow.
4. Do not place shotcrete on frozen surfaces or surfaces containing frozen materials.
5. Do not use calcium chloride, salt, or other materials containing antifreeze agents.

**KOPACHUCK STATE PARK
DAY USE DEVELOPMENT**

- C. Hot-Weather Shotcreting: Mix, place, and protect shotcrete according to ACI 305R when hot-weather conditions and high temperatures would seriously impair quality and strength of shotcrete, and as follows:
 - 1. Cool ingredients before mixing to maintain shotcrete temperature at time of placement below 100 deg F for dry-mix or 90 deg F for wet mix.
- D. Reduce temperature of reinforcing steel and receiving surfaces below 100 deg F before shotcreting.

3.6 CONSTRUCTION JOINTS

- A. Construction Joints: Joints shall be avoided to the greatest extent possible. If necessary, locate and install construction joints tapered to a 1:1 Slope where joint is not subject to compression loads and square where joint is perpendicular to main reinforcement. Continue reinforcement through construction joints, unless otherwise indicated.
 - 1. Place joints perpendicular to main reinforcement. Continue reinforcement across construction joints, unless otherwise indicated.
 - 2. Face of shotcrete shall be finished rough to allow more bonding area.

3.7 SURFACE FINISHES

- A. General: Finish shotcrete according to descriptions in ACI 506R for the following:
- B. Final Finish: Shotcrete finish and texture shall match Bandera Granite approved Mock Ups.
- C. Color: Color shall match the natural rock surface of Bandera Granite.
 - 1. Conform to ASTM C979.
 - 2. Compatibility with Concrete Mix.
 - 3. All shotcrete will be integrally colored in addition to the surface applied coloring.

3.8 CURING

- A. Protect freshly placed shotcrete from premature drying and excessive cold or hot temperatures.
- B. Start initial curing as soon as free water has disappeared from shotcrete surface after placing and finishing.
- C. Curing Exposed Surfaces: Cure shotcrete by one of the following methods:
 - 1. Moisture Curing: Keep surfaces continuously moist for at least seven days with water, continuous water-fog spray, and water saturated absorptive covers, or moisture-retaining covers. Lap and seal sides and ends of covers.
- D. Curing Formed Surfaces: Cure formed shotcrete surfaces by moist curing with forms in place for full curing period or until forms are removed. If forms are removed, continue curing by methods specified above, as applicable.

**KOPACHUCK STATE PARK
DAY USE DEVELOPMENT**

3.9 REPAIRS AND REPLACEMENT OF DEFECTIVE CONCRETE

- A. Remove and replace shotcrete that is delaminated or exhibits laminations, voids, or sand/rock pockets exceeding limits for specified core grade of shotcrete.
 - 1. Remove unsound or loose materials and contaminants that may inhibit bond of shotcrete repairs. Chip or scarify areas to be repaired to extent necessary to provide sound substrate. Cut edges square and ½-inch deep at perimeter of work, tapering remaining shoulder at 1:1 slope into cavity to eliminate square shoulders. Dampen surfaces and apply new shotcrete or patching mortar.
- B. Repair to match adjacent finish. Texture and color.

END OF SECTION - 033713

**KOPACHUCK STATE PARK
DAY USE DEVELOPMENT**

SECTION 035400 – CAST UNDERLAYMENT

PART 1 – GENERAL

1.1 SECTION INCLUDES

- A. Liquid-applied self-leveling floor underlayment.
 - 1. Gypsum-cement based, self leveling underlayment.

1.2 RELATED REQUIREMENTS

- A. Division 9 Flooring sections.

1.3 SUBMITTALS

- A. Product Data: Provide manufacturer's data sheets documenting physical characteristics and product limitations of underlayment materials. Include information on surface preparation, environmental limitations, and installation instructions.
- B. Certificate: Certify that products meet or exceed specified requirements.

1.4 QUALITY ASSURANCE

- A. Installer Qualifications: Company specializing in performing the work of this section with minimum 3 years of experience.
 - 1. Installer shall be listed with the manufacturer as a having special skill in this work.
 - 2. Ardex "Level Master" or similar level of training and experience as rated by other manufacturers wishing to bid the work.

1.5 DELIVERY, STORAGE, AND HANDLING

- A. Store products in manufacturer's unopened packaging until ready for installation.
- B. Keep dry and protect from direct sun exposure, freezing, and ambient temperature greater than 105 degrees F.

1.6 MOCK-UP

**KOPACHUCK STATE PARK
DAY USE DEVELOPMENT**

- A. Provide a mock-up for evaluation of surface preparation techniques and application workmanship.
 - 1. Prepare mock-up in location designated by Architect.
 - 2. Area: 6 ft x 6 ft minimum.
 - 3. Do not proceed with underlayment work until workmanship of mock-up has been approved by Architect.

1.7 REGULATORY REQUIREMENTS

- A. Conform to applicable code for combustibility or flame spread requirements.
- B. Provide certificate of compliance from authority having jurisdiction indicating approval of underlayment materials in the required fire rated assembly.

1.8 FIELD CONDITIONS

- A. Do not install underlayment until floor penetrations and peripheral work are complete.
- B. Maintain minimum ambient temperatures of 50 degrees F 24 hours before, during and 72 hours after installation of underlayment.
- C. During the curing process, ventilate spaces to remove excess moisture.

PART 2 - PRODUCTS

2.1 DESCRIPTION

- A. Calcium aluminate based self-leveling underlayment.
- B. Provide products with compressive strengths over 4000 psi by Ardex, Laticrete, or approved.

2.2 MATERIALS

- A. Gypsum-Based Underlayment: Gypsum based mix, that when mixed with water in accordance with manufacturer's directions will produce self-leveling underlayment with the following properties:
 - 1. Basis of Design: USG Corp., or other reviewed and approved manufacturers.
 - 2. Products: Poured floor underlayment and topping products including the following:
 - 3. LEVELROCK® 3500™ Floor Underlayment:

**KOPACHUCK STATE PARK
DAY USE DEVELOPMENT**

- a. Material: Gypsum Cement
 - b. Minimum Compressive Strength (ASTM C472): 3,500psi.
(Avg. 3,500 -4,200) psi (24.13 - 28.96) MPa.
 - c. Nominal Average Density: 115 pounds per cubic foot.
- B. Aggregate: Dry, well graded, washed silica aggregate, approximately 1/8 inch in size and acceptable to underlayment manufacturer.
- C. Reinforcement: Galvanized metal lath complying with recommendations of underlayment manufacturer for specific project circumstances.
- D. Water: Potable and not detrimental to underlayment mix materials.
- E. Primer: Manufacturer's recommended type.
- F. Joint and Crack Filler: Cementitious type recommended by manufacturer.

2.3 MIXING

- A. Site mix materials in accordance with manufacturer's instructions.
- B. Add aggregate for areas where thickness will exceed 1/2 inch. Mix underlayment and water for at least two minutes before adding aggregate and continue mixing to assure that aggregate has been thoroughly coated.
- C. Mix to self-leveling consistency without over-watering.

PART 3 – EXECUTION

3.1 EXAMINATION

- A. Verify that substrate surfaces are clean, dry, unfrozen, do not contain petroleum byproducts, or other compounds detrimental to underlayment material bond to substrate.

3.2 PREPARATION

- A. Wood: Install metal lath for reinforcement of underlayment.
- B. Remove substrate surface irregularities. Fill voids and deck joints with filler. Finish smooth.
- C. Vacuum clean surfaces.
- D. Prime substrate in accordance with manufacturer's instructions.

**KOPACHUCK STATE PARK
DAY USE DEVELOPMENT**

- E. Close floor openings.

3.3 APPLICATION

- A. Install underlayment in accordance with manufacturer's instructions.
- B. Pump or pour material onto substrate. Do not retemper or add water.
 - 1. Pump, move, and screed while the material is still highly flowable.
 - 2. Be careful not to create cold joints.
 - 3. Wear spiked shoes while working in the wet material to avoid leaving marks.
- C. For final thickness over 1-1/2 inches, place underlayment in layers. Allow initial layer to harden to the point where the material has lost its evaporative moisture. Immediately prime and begin application of the subsequent layer within 24 hours.
- D. Place before partition installation.
- E. Where additional aggregate has been used in the mix, add a top layer of neat mix (without aggregate), if needed to level and smooth the surface.
- F. If a fine, feathered edge is desired, steel trowel the edge after initial set, but before it is completely hard.

3.4 CURING

- A. Once underlayment starts to set, prohibit foot traffic until final set has been reached.
- B. Air cure in accordance with manufacturer's instructions.

3.5 FIELD QUALITY CONTROL

- A. An independent testing agency will perform field inspection and testing, as specified in Section 014000 Quality Requirements.
- B. Placed Material: Agency will inspect and test for conformance to specification requirements.
- C. Slump Test: Conduct test using a 2 inch x 4 inch cylinder. The acceptable slump is a patty size of 8-9.5 inches diameter.
 - 1. Slump test shall be taken at the beginning of each installation in order to verify the required slump. Slump test shall be taken at a minimum of every 2500 sq. ft. during installation.
- D. Compressive Strength: Take at least one set of 3 molded cube samples from every 10,000 sq. ft

**KOPACHUCK STATE PARK
DAY USE DEVELOPMENT**

and at least one set of cubes per day during the underlayment installation,

1. Conduct test in accordance with ASTM C472.
2. Make independent test reports available to project team.

3.6 PROTECTION

- A. Protect against direct sunlight, heat, and wind; prevent rapid drying to avoid shrinkage and cracking.
- B. Do not permit traffic over unprotected floor underlayment surfaces unless allowed in writing by manufacturer.

END OF SECTION 035400

**KOPACHUCK STATE PARK
DAY USE DEVELOPMENT**

SECTION 055000 – METAL FABRICATIONS

PART 1 – GENERAL

1.1 RELATED DOCUMENTS

- A. Drawings and general provisions of the Contract, including General Conditions and Division 1 Specifications, apply to this Section.

1.2 SUMMARY

- A. This section includes fabrication and installation of all metal fabrication, including, but not limited to the following. All materials shall be hot-dip galvanized after fabrication.
 - 1. Exterior Handrails and Mesh Panels.
 - 2. Park Entry and Exit Gates
 - 3. Miscellaneous Exterior Metal.

1.3 RELATED WORK SPECIFIED ELSEWHERE

- A. Section 101400 – Signs, for powder coating.

1.4 QUALITY ASSURANCE

- A. Standards: Conform to American Institute of Steel Construction's (AISC) "Specifications for the Design, Fabrication and Erection of Structural Steel for Buildings" and "Code of Standard Practice for Steel Buildings and Bridges;" and to American Welding Society's (AWS) "Standard Code for Welding in Building Construction."
- B. Building Code: Conform to requirements of International Building Code as supplemented and modified herein.
- C. All welding shall be by a WABO certified welder.

1.5 REFERENCES

- A. ASTM A36/A36M – Structural Steel.
- B. ASTM A123/A123M – Zinc-Coating (Hot-Dip) on Assembled Steel.
- C. AWS D1.1 – Structural Welding Code.
- D. ASTM A480/A480M – Stainless and Heat-Resisting Chromium-Nickel Steel Plate, Sheet, and Strip.

**KOPACHUCK STATE PARK
DAY USE DEVELOPMENT**

1.6 SHOP DRAWINGS

- A. Submit shop drawings under provisions of Section 013300 – Submittal Procedures:
 - 1. Exterior Handrails and Mesh Panels
 - 2. Park Entry and Exit Gates.
- B. Indicate profiles, sizes, connection attachments, reinforcing, anchorage, size, and type of fasteners, and accessories.
- C. Include erection drawings, elevations, and details where applicable.
- D. Indicate welded connections using standard AWS welding symbols. Indicate net weld lengths.

PART 2 – PRODUCTS

2.1 EXTERIOR HANDRAILS

- A. Shall be standard-weight steel pipe conforming to ASTM Specification A53/A53M.

2.2 STRUCTURAL STEEL

- A. Structural steel to conform to ASTM A36/A36M.

2.3 FASTENERS

- A. Nuts and Washers: ASTM A307.
- B. All fasteners to be hot dip galvanized unless otherwise noted.

2.4 GALVANIZING

- A. Comply with ASTM A123/A123M for zinc coatings on assembled steel products.
 - 1. Weight of coating per Table I for class and thickness of material to be coated. Galvanize after fabrication.

2.5 POWDER COATING

- A. Final finish is powder coating on handrails, mesh panels, any brackets, and entry and exit gates.

**KOPACHUCK STATE PARK
DAY USE DEVELOPMENT**

- B. Powder Coat Finish: Shall be electrostatically applied polyester powder. All components will be free of sharp edges and excess weld spatter. The coating shall meet the following:
1. 3.0 – 5.0 mil thickness and over cured between 375° to 425° F.
 2. Pencil Hardness: H, ASTM D3363.
 3. Impact: ASTM D2794.
 4. Wedge Bend: ASTM D522.
 5. Adhesion: Cross hatch ASTM D3359 and knife scratch ASTM D2197.
 6. Environmental: Stain resistance ASTM D1308.
 7. Salt Spray: ASTM B117 and Fadometer 300 hours with no loss of gloss.
 8. Overbake Stability: 100% at 400° F.
 9. Color: To Be Selected. Submit sample color to Owner's Representative for approval prior to powder coating.

2.6 EPOXY GROUT

- A. High strength epoxy adhesive permitted for use on core drilled holes.

PART 3 – EXECUTION

3.1 FABRICATION, GENERAL

- A. Verify dimensions on site prior to shop fabrication.
- B. Fabricate items with joints tightly fitted and allowing for expansion and contraction.
- C. Provide weep holes or other means to drain entrapped water and low points of handrail.
- D. Fit and shop assemble in largest practical sections for delivery to site.
- E. Grind exposed welds flush and smooth with adjacent finished surface. Ease exposed edges to small uniform radius.
- F. Exposed Mechanical Fastenings: Flush countersunk screws or bolts unobtrusively located consistent with design of structure, except where specifically noted otherwise.
- G. Make exposed joints butt tight, flush, and hairline.
- H. Supply components required for anchorage of metal fabrications. Fabricate anchorage and related components of same material and finish as metal fabrication, except where specifically noted otherwise.

**KOPACHUCK STATE PARK
DAY USE DEVELOPMENT**

3.2 EXTERIOR HANDRAILS

A. Fabrication:

1. Jointing of post and rail shall be by mitered and welded joints made by fitting posts to rails, groove welding joints, and grinding smooth. Railing splices shall be butted and reinforced by a tight-fitting interior sleeve not less than 6 inches long. Handrails shall be hot-dip galvanized after fabrication. No field welds.
2. Finish shall be smooth with no sharp or protruding burrs (as determined by the Owner's Representative).

B. Installation:

1. At Wood Post: Coordinate wood post locations and rail connections so rail connections are at the center of the post.

C. Finish:

1. Hot-dipped galvanized.

3.3 PARK ENTRY AND EXIT GATES

- A. Construct as detailed. Set gates level, with both sides in align and with lock posts.

3.4 CLEANUP

- A. Contractor shall leave grounds in good condition, and leave metal fabrications complete and workable in all details.

END OF SECTION 055000

**KOPACHUCK STATE PARK
DAY USE DEVELOPMENT**

SECTION 060555 – SELECTIVE TREE SALVAGE

PART 1 - GENERAL

1.1 SUMMARY

- A. Section includes grading and harvesting of existing on-site trees for removal and re-use as round wood poles to be used in construction of the Park Entry Sign and / or the Play Tower Structures as directed.
- B. Removal, transportation, milling, drying, and storage of timber produced from on-site salvaged trees suitable for re-use as round wood poles as specified in Section 061300 – Round Wood Poles.

1.2 DEFINITIONS

- A. Salvaged Tree: Existing on-site tree from the project site, meeting minimum requirements specified within this section and Section 061300 – Round Wood Poles.
- B. Arborist: An individual engaged in the profession of arboriculture who, through experience, education, and related training, possesses the competence to provide for, or supervise the management and harvesting of trees and other woody plants.
- C. Poles: Round wood members, called either "poles" or "posts" in the reference standards.
- D. Inspection agencies, and the abbreviations used to reference them, include the following:
 - 1. ANSI: American National Standards Institute – A300 Standards for Tree Care Operations
 - 2. FSC: Forest Stewardship Council
 - 3. PLIB: Pacific Lumber Inspection Bureau.
 - 4. WWPA: Western Wood Products Association.
 - 5. NLGA: National Lumber Grades Authority.

1.3 INFORMATIONAL SUBMITTALS

- A. Existing on-site Tree Evaluation and Maximization Plan, prepared by a qualified arborist in coordination with the contractor, including the following:
 - 1. Evaluation to include inventory of all existing trees designated for culling as shown on Contract Drawings.
 - 2. Development of a plan to maximize the yield from the timbers, considering species, health, required dimensions, and cut lengths in accordance with the intended use.
 - 3. Grading of existing trees, confirming compliance with requirements of the work and assessing their suitability for use as round wood poles.
 - 4. Notification of discrepancies in existing conditions as compared to pre-bid inspections.
 - 5. Notification of damaged and / or unusable trees or portions thereof.

**KOPACHUCK STATE PARK
DAY USE DEVELOPMENT**

- B. Contractor and Arborist Qualifications:
 - 1. Provide proof of Contractor and Arborist qualifications as specified under Quality Assurance.
- C. Chain of Custody Report:
 - 1. Include log / timber tracking information, condition photographs, and markings used to confirm material harvested remains material used as required in the Work.
- D. Off-Site Lumber Processing and Storage:
 - 1. Off-site processing and storage conditions information including contact information for lumber processor and storage address(es).

1.4 QUALITY ASSURANCE

- A. Qualifications:
 - 1. Contractor specializing in the Work of this Section shall have a minimum of 3 years experience performing similar work.
 - 2. Arborists conducting Work of this Section shall have appropriate training and a minimum of 3 years experience performing similar work.
- B. Regulatory Requirements:
 - 1. Work of this Section shall conform to all Federal, State, County, and local regulations.
- C. All work shall be performed in a professional manner, utilizing the proper equipment, safety protocols, and trained personnel.
- D. The tree removal contractor is expected to collaborate closely with a local lumber processor to ensure the timbers meet the specific requirements of the proposed use as round wood poles / logs.
- E. The lumber processor is expected to have a relationship with a lumber inspection company to provide transient inspection and grading of structural timber.

1.5 DELIVERY, STORAGE AND HANDLING

- A. Schedule delivery of materials to avoid extended on-site storage and to avoid delaying the Work.
- B. Store materials under cover and protected from weather and contact with damp or wet surfaces. Provide for air circulation within and around stacks and under temporary coverings.

**KOPACHUCK STATE PARK
DAY USE DEVELOPMENT**

PART 2 - PRODUCTS

2.1 ROUND WOOD POLES

- A. Round Wood Poles: Salvaged Trees to be used as Round Wood Poles shall comply with all Fabrication and Treatment requirements listed in Section 061300 – Round Wood Poles.
 - 1. Limbs cut and removed tight to log surface.
 - 2. No holes or rotten / soft wood allowed.
 - 3. Logs shall be scanned for metal and all detected metal shall be clearly marked with temporary contrasting color marking.
 - 4. Any logs containing metal shall be evaluated as to whether the affected section can be removed while still meeting dimensional requirements of remaining section(s) to be re-used.

2.2 EXCESS MATERIALS

- A. Remaining excess harvested trees and other materials not meeting requirements for re-use shall be removed from site as specified in Section 017419 – Construction and Waste Management and Disposal, and Section 024000 – Demolition, where appropriate.

PART 3 - EXECUTION

3.1 VERIFICATION OF EXISTING CONDITIONS

- A. Verify existing site conditions match those of the survey and pre-bid inspections. Notify Owner's Representative of any discrepancies in writing prior to commencement of Work.

3.2 PROTECTION

- A. Contractor shall provide adequate protection measures to protect workers and pedestrians at the site during tree harvesting operations.
- B. Provide for surface drainage during on-site tree harvesting operations to avoid creating a nuisance to adjacent areas.
- C. Prevent damage to existing improvements designated to remain. If any existing improvements are damaged during construction, restore existing improvements to their original condition.

3.3 ON-SITE TREE HARVESTING

- A. Accurate Cut Lengths: Precise cut lengths at specific dimensions are critical to align with the requirements outlined in the Contract Drawings and Specifications.
- B. Minimize Damage: All efforts shall be made to minimize damage to the timber during the harvesting process.

**KOPACHUCK STATE PARK
DAY USE DEVELOPMENT**

- C. Log Preservation: Once trees are felled, logs shall be handled with care to prevent any undue damage or harm.
- D. Reduce Impact on Surrounding Area: The Contractor shall prevent damage from trees, branches, and equipment from occurring to surrounding area while minimizing ground disturbance.
- E. Documentation: A detailed inventory of all logs shall be performed and logs shall be labeled, documented, and organized based on their intended use either for the Park Entry Structure or for the Play Tower Structure. Records should include photographs, measurements, and documentation of any damage sustained during removal.
- F. Grading: Contractor shall work with Arborist and inspection company to have logs graded in accordance with the requirements of Section 061300 – Round Wood Poles.
- G. Transportation: Contractor shall work with lumber processor in arranging transport of logs to be milled and kiln dried as required for use as Round Wood Poles.

3.4 STUMPS, LIMBS, AND DEBRIS

- A. Stumps: All stumps are to be removed by Contractor unless noted otherwise on Contract Drawings.
- B. Limbs, Debris, and other materials: All tree limbs, branches, and other debris generated during the tree harvesting process are to be collected, removed, and properly disposed of off-site.
- C. Logs not designated for re-use as Round Wood Poles should be preferentially salvaged, repurposed, or collected, removed, and properly disposed of off-site.

3.5 PROCESSING FOR RE-USE

- A. Upon receipt of salvaged trees identified for re-use as Round Wood Poles, the Lumber Processor shall mill, kiln dry, and profile the logs into Round Wood Poles per Section 061300 – Round Wood Poles for use in construction of the Park Entry Structure and / or the Play Tower Structure per dimensional and other requirements as shown on Contract Drawings.
- B. Tree Removal Contractor and Lumber Processor are expected to collaborate closely in order to detail specific requirements for the total number and size of salvaged trees required to satisfy the quantity needed to construct the Park Entry Structure and / or the Play Tower Structure. In addition, they must align their timelines to ensure that the prepared Round Wood Poles are available when they are needed to construct the proposed improvements.

3.6 DELIVERY

- A. The Lumber Processor shall arrange for the timely and secure delivery of the processed logs to the specified location within Kopachuck State Park, where directed by the Contractor.

**KOPACHUCK STATE PARK
DAY USE DEVELOPMENT**

- B. The delivery schedule should be coordinated with the construction timeline to ensure that the Round Wood Poles derived from the salvaged trees are available when they are needed to construct the proposed improvements.
- C. The Lumber Processor is responsible for ensuring that the delivered logs meet the specifications and requirements of the Contract Drawings, including the required profile, dimensions, treatment, and moisture percentage.

END OF SECTION 060555

**KOPACHUCK STATE PARK
DAY USE DEVELOPMENT**

SECTION 061000 – ROUGH CARPENTRY

PART 1 - GENERAL

1.1 SECTION INCLUDES

- A. Structural dimension lumber framing.
- B. Non-structural dimension lumber framing.
- C. Rough opening framing for doors, windows, and roof openings.
- D. Structural floor, wall, and roof framing.
- E. Roofing nailers.
- F. Preservative treated wood materials.
- G. Miscellaneous framing and sheathing.
- H. Communications and electrical room mounting boards.
- I. Concealed wood blocking, nailers, and supports.
- J. Miscellaneous wood nailers, furring, and grounds.

1.2 RELATED REQUIREMENTS

- A. Section 055000 - Metal Fabrications: Miscellaneous steel connectors and support angles for wood framing.
- B. Section 072500 - Weather Barriers: Water-resistive barrier over sheathing.
- C. Section 092116 - Gypsum Board Assemblies: Gypsum-based sheathing.
- D. Section 061600 – Sheathing.

1.3 REFERENCE STANDARDS

- A. ASTM A153/A153M - Standard Specification for Zinc Coating (Hot-Dip) on Iron and Steel Hardware; 2009.

**KOPACHUCK STATE PARK
DAY USE DEVELOPMENT**

- B. ASTM E84 - Standard Test Method for Surface Burning Characteristics of Building Materials; 2015a.
- C. PS 1 - Structural Plywood; 2009.
- D. PS 2 - Performance Standard for Wood-Based Structural-Use Panels; 2010.
- E. PS 20 - American Softwood Lumber Standard; 2010.
- F. WCLIB (GR) - Standard Grading Rules for West Coast Lumber No. 17; 2004, and supplements.
- G. WWPA G-5 - Western Lumber Grading Rules; 2011.

1.4 SUBMITTALS

- A. See Section 013300 - Submittal Procedures.
- B. Product Data: Provide technical data on insulated sheathing, wood preservative materials, and application instructions.

1.5 QUALITY ASSURANCE

- A. Lumber: Comply with PS 20 and approved grading rules and inspection agencies.

1.6 DELIVERY, STORAGE, AND HANDLING

- A. General: Cover wood products to protect against moisture. Support stacked products to prevent deformation and to allow air circulation.

PART 2 - PRODUCTS

2.1 GENERAL REQUIREMENTS

- A. Dimension Lumber: Comply with PS 20 and requirements of specified grading agencies.
 - 1. If no species is specified, provide any species graded by the agency specified; if no grading agency is specified, provide lumber graded by any grading agency meeting the specified requirements.

**KOPACHUCK STATE PARK
DAY USE DEVELOPMENT**

2. Grading Agency: Any grading agency whose rules are approved by the Board of Review, American Lumber Standard Committee (www.alsc.org) and who provides grading service for the species and grade specified; provide lumber stamped with grade mark unless otherwise indicated.

B. Lumber fabricated from old growth timber is not permitted.

C. Comply with General Notes on Structural Drawings. Notify Architect regarding any conflicts between this section and Structural Drawings.

2.2 DIMENSION LUMBER

A. Grading Agency: Pacific Lumber Inspection Bureau; PLIB (GR).

B. Sizes: Nominal sizes as indicated on drawings.

C. Moisture Content: MC-19.

D. Stud Framing (2 by 2 through 2 by 6):

1. Grade: No. 2.

E. Miscellaneous Framing, Blocking, Nailers, Grounds, and Furring:

1. Lumber: S4S, No. 2 or Standard Grade.
2. Boards: Standard or No. 3.

2.3 CONSTRUCTION PANELS

A. Communications and Electrical Room Mounting Boards: PS 1 A-D plywood, or medium density fiberboard; 3/4 inch thick; flame spread index of 25 or less, smoke developed index of 450 or less, when tested in accordance with ASTM E84.

1. At least one fire retardant stamp or permanent label shall be visible on each sheet of plywood.
2. Paint white with two (2) coats of fire retardant paint.

2.4 ACCESSORIES

A. Fasteners and Anchors:

1. Metal and Finish: Hot-dipped galvanized steel complying with ASTM A153/A153M for high humidity and preservative-treated wood locations, unfinished steel elsewhere.

**KOPACHUCK STATE PARK
DAY USE DEVELOPMENT**

- B. Sill Gasket on Top of Foundation Wall: 1/4 inch thick, plate width, closed cell plastic foam from continuous rolls.

PART 3 – EXECUTION

3.1 PREPARATION

- A. Install sill gasket under sill plate of framed walls bearing on foundations; puncture gasket cleanly to fit tightly around protruding anchor bolts.
- B. Coordinate installation of rough carpentry members specified in other sections.

3.2 INSTALLATION – GENERAL

- A. Select material sizes to minimize waste.
- B. Reuse scrap to the greatest extent possible; clearly separate scrap for use on site as accessory components, including: shims, bracing, and blocking.

3.3 FRAMING INSTALLATION

- A. Refer to General Structural Notes on drawings.
- B. Set structural members level, plumb, and true to line. Discard pieces with defects that would lower required strength or result in unacceptable appearance of exposed members.
- C. Make provisions for temporary construction loads, and provide temporary bracing sufficient to maintain structure in true alignment and safe condition until completion of erection and installation of permanent bracing.
- D. Install structural members full length without splices unless otherwise specifically detailed.
- E. Comply with member sizes, spacing, and configurations indicated, and fastener size and spacing indicated, but not less than required by applicable codes and AFPA (WFCM) Wood Frame Construction Manual.
- F. Construct double joist headers at floor and ceiling openings and under wall stud partitions that are parallel to floor joists; use metal joist hangers unless otherwise detailed.
- G. Frame wall openings with two or more studs at each jamb; support headers on cripple studs.

**KOPACHUCK STATE PARK
DAY USE DEVELOPMENT**

3.4 BLOCKING, NAILERS, AND SUPPORTS

- A. Provide framing and blocking members as indicated or as required to support finishes, fixtures, specialty items, and trim.
- B. In framed assemblies that have concealed spaces, provide solid wood fireblocking as required by applicable local code, to close concealed draft openings between floors and between top story and roof/attic space; other material acceptable to code authorities may be used in lieu of solid wood blocking.
- C. In walls, provide blocking attached to studs as backing and support for wall-mounted items, unless item can be securely fastened to two or more studs or other method of support is explicitly indicated.
- D. Where ceiling-mounting is indicated, provide blocking and supplementary supports above ceiling, unless other method of support is explicitly indicated.

3.5 ROOF-RELATED CARPENTRY

- A. Coordinate installation of roofing carpentry with deck construction, framing of roof openings, and roofing assembly installation.
- B. Provide wood curb at all roof openings except where specifically indicated otherwise. Form corners by alternating lapping side members.

3.6 INSTALLATION OF CONSTRUCTION PANELS

- A. Underlayment: Secure to subflooring with nails and glue.
 - 1. At locations where resilient flooring will be installed, fill and sand splits, gaps, and rough areas. Install per resilient flooring manufacturer recommendations.
- B. Wall Sheathing: Secure with long dimension perpendicular to wall studs, with ends over firm bearing and staggered, using nails, screws, or staples.
 - 1. Place water-resistive barrier horizontally over wall sheathing, weather lapping edges and ends.
- C. Communications and Electrical Room Mounting Boards: Secure with screws to studs with edges over firm bearing; space fasteners at maximum 24 inches on center on all edges and into studs in field of board.
 - 1. At fire-rated walls, install board over wall board indicated as part of the fire-rated assembly.
 - 2. Where boards are indicated as full floor-to-ceiling height, install with long edge of board parallel to studs.
 - 3. Install adjacent boards without gaps.

END OF SECTION 061000

**KOPACHUCK STATE PARK
DAY USE DEVELOPMENT**

SECTION 061300 – ROUND WOOD POLES

PART 1 - GENERAL

1.1 SUMMARY

- A. Section includes framing using round wood poles.
 - 1. Related Requirements: 055000 – Metal Fabrications
 - a. Metal connection plates and bolts.

1.2 DEFINITIONS

- A. Poles: Round wood members, called either "poles" or "posts" in the referenced standards.
- B. Inspection agencies, and the abbreviations used to reference them, include the following:
 - 1. PLIB: Pacific Lumber Inspection Bureau.
 - 2. WWPA: Western Wood Products Association.
 - 3. National Lumber Grades Authority.

1.3 INFORMATIONAL SUBMITTALS

- A. Certificates of Inspection: Issued by lumber-grading agency for exposed timber not marked with grade stamp.

1.4 DELIVERY, STORAGE, AND HANDLING

- A. Schedule delivery of materials to avoid extended on-site storage and to avoid delaying the Work.
- B. Store materials under cover and protected from weather and contact with damp or wet surfaces. Provide for air circulation within and around stacks and under temporary coverings.

PART 2 - PRODUCTS

2.1 ROUND WOOD POLES

- A. Round Wood Poles: Clean-peeled wood poles complying with ASTM D 3200; with at least 80 percent of inner bark removed and with knots and limbs cut flush with the surface.
 - 1. Quality: Suitable for exposed exterior use with transparent finish.

**KOPACHUCK STATE PARK
DAY USE DEVELOPMENT**

- B. Species: Western Red Cedar.

2.2 MISCELLANEOUS MATERIALS

- A. End Sealer: Manufacturer's standard, transparent, colorless wood sealer that is effective in retarding the transmission of moisture at cross-grain cuts and is compatible with indicated finish.
- B. Penetrating Sealer: Manufacturer's standard, transparent, penetrating wood sealer that is compatible with indicated finish.
- C. Connectors and Fasteners: Detailed on Structural drawings, material and fabrication specified in Section 055000.

2.3 FABRICATION

- A. Shop fabricate members by cutting and restoring exposed surfaces to match specified surfacing. Finish exposed surfaces to remove planing or surfacing marks, and to provide a finish equivalent to that produced by machine sanding with No. 120 grit sandpaper.
- B. Coat crosscuts with end sealer.
- C. Seal Coat: After fabricating and surfacing each unit, apply a saturation coat of penetrating sealer on surfaces of each unit except for treated wood where the treatment included a water repellent.

PART 3 - EXECUTION

3.1 INSTALLATION

- A. General: Erect round wood poles true and plumb. Provide temporary bracing to maintain lines and levels until permanent supporting members are in place.
- B. Fitting: Fit members by cutting and restoring exposed surfaces to match specified surfacing.
 - 1. Predrill for fasteners using metal connectors as templates.
 - 2. Coat crosscuts with end sealer. Coat cuts that will be inaccessible after erection with end sealer.
- C. Install column connectors as indicated on Structural drawings.
 - 1. Install bolts with orientation as indicated or, if not indicated, as directed by Architect.

**KOPACHUCK STATE PARK
DAY USE DEVELOPMENT**

3.2 ADJUSTING

- A. Repair damaged surfaces and finishes after completing erection. Replace damaged round wood poles if repairs are not approved by Architect.

END OF SECTION 061300

**KOPACHUCK STATE PARK
DAY USE DEVELOPMENT**

SECTION 061500 – HEAVY TIMBER CONSTRUCTION

PART 1 - GENERAL

1.1 DESCRIPTION

- A. Drawings and general provisions of the Contract, including General Conditions and Division 1 Specifications, apply to this Section.

1.2 SUMMARY

- A. Work includes:
 - 1. Heavy Timber Structural Members
 - 2. Connection Hardware

1.3 ALTERNATIVES

- A. See Bid Form for possible effects on this section.

1.4 APPLICABLE PUBLICATIONS

- A. American Society of Testing and Materials (ASTM)
- B. American Institute of Timber Construction (AITC)
- C. American Wood Preservers Association (AWPA)
- D. American Wood Preservers Bureau (AWPB)
- E. West Coast Lumber Inspection Bureau (WCLIB)
- F. International Building Code (IBC)

1.5 SUBMITTALS

- A. Certification of conformance with material standards, including wood preservative treatment certificates.

**KOPACHUCK STATE PARK
DAY USE DEVELOPMENT**

1.6 PRODUCT DELIVERY, STORAGE, AND HANDLING

- A. Contractor shall take care in establishing handling methods to avoid damage during storage, assembly, and installation. Clear ground underneath stored materials, and in the vicinity, of all weeds, rubbish and combustible materials. Storage of material shall be on level surfaces, and it shall be the responsibility of the Contractor to determine how high to stack material to avoid damage. Care shall be taken to avoid damage caused by over-stacking. Storage and handling shall conform to AWWA M4.

PART 2 - PRODUCTS

2.1 HEAVY TIMBER/LUMBER

- A. Lumber shall be of the nominal dimensions indicated on the drawings.
- B. All lumber shall conform to the requirements of WCLIB grading and dressing rules and the Structural Notes for Structural Wood shown on the Contract Drawings.

2.2 PRESERVATIVE TREATMENT

- A. Wood preservative treatment shall conform to Structural Notes for Structural Wood shown on the Contract Drawings.

2.3 HARDWARE

- A. Bolts and nuts shall conform to ASTM A307.

All hardware, including all fasteners, shall be hot dipped galvanized in accordance with ASTM A123/ A123M or ASTM A153/ A153M as applicable.

Plate or malleable washers shall be used with all nuts and bolts which bear on wood and cut washers on all nuts which bear on steel.

Framing anchors shall conform to Structural Notes for Structural Wood shown in the Plans.

- B. Through bolts only will be used to fasten primary structural members of wood together. No nails, screws, or lag screws will be allowed for these connections.

PART 3 - EXECUTION

3.1 FRAMING

- A. Accurately cut and frame all lumber in such a manner that the joints will have a close fit over the entire contact surfaces. Secure members in their proper alignment. No shimming will be permitted in making joints, nor will open joints be accepted.

**KOPACHUCK STATE PARK
DAY USE DEVELOPMENT**

3.2 HOLES FOR BOLTS

- A. Bore bolt holes in heavy timber with a bit 1/16-inch larger in diameter than the bolt.
- B. Bore holes in small timbers for screws or nails with a bit of the same diameter or smallest dimension of the screw or nail to prevent splitting.

3.3 FIELD TREATMENT OF CUT SURFACES, BOLT HOLES, AND CONTACT SURFACES

- A. Field treat all cuts in timbers and all abrasions in accordance with AWP A M4. Trim all cuts and abrasions before field treatment. Paint all depressions or openings around bolt holes, joints or daps, including recesses formed by counter-boring, with the appropriate preservative.

3.4 FASTENING

- A. Use washers of the size and type specified under all hex bolt nuts which would otherwise come in contact with wood.
 - 1. Check all bolts after the nuts have finally tightened.
 - 2. Vertical bolts shall have nuts on the lower end.
 - 3. In all cases where bolts are used to fasten timber to timber or timber to steel, bolt members tightly together when they are installed and retighten immediately prior to final acceptance of the Work.
 - 4. All bolts shall have sufficient additional threading to provide at least 3/8-inch per foot thickness of timber for future retightening. Tighten all bolts prior to final acceptance.
 - 5. Peen all bolt ends.

END OF SECTION 061500

**KOPACHUCK STATE PARK
DAY USE DEVELOPMENT**

SECTION 061600 - SHEATHING

PART 1 - GENERAL

1.1 SUMMARY

A. Section Includes:

1. Wall sheathing.
2. Roof sheathing.
3. Subflooring.
4. Note: Communication and Electrical Room Mounting Boards are specified in Section 061000 – Rough Carpentry.

1.2 ACTION SUBMITTALS

- A. Product Data: For each type of process and factory-fabricated product.

PART 2 - PRODUCTS

2.1 WOOD PANEL PRODUCTS

- A. Emissions: Products shall meet the testing and product requirements of the California Department of Public Health's "Standard Method for the Testing and Evaluation of Volatile Organic Chemical Emissions from Indoor Sources Using Environmental Chambers."

2.2 WALL SHEATHING

- A. Plywood Sheathing: See Structural drawings.
- B. Oriented-Strand-Board Sheathing: See Structural drawings.
- C. Cementitious Backer Units: ASTM C 1325, Type A.
1. Thickness: 1/2" inch.

2.3 ROOF SHEATHING

- A. Plywood Sheathing: See Structural drawings.

2.4 SUBFLOORING

- A. Plywood Subflooring: See Structural drawings.

**KOPACHUCK STATE PARK
DAY USE DEVELOPMENT**

- B. Underlayment: See Section 035400 – Cast Underlayment.

2.5 FASTENERS

- A. General: Provide fasteners of size and type indicated on Structural drawings.

PART 3 - EXECUTION

3.1 INSTALLATION, GENERAL

- A. Do not use materials with defects that impair quality of sheathing or pieces that are too small to use with minimum number of joints or optimum joint arrangement. Arrange joints so that pieces do not span between fewer than three support members.
- B. Cut panels at penetrations, edges, and other obstructions of work; fit tightly against abutting construction unless otherwise indicated.
- C. Securely attach to substrate by fastening as indicated, complying with the following:
 - 1. Table 2304.10.1, "Fastening Schedule," in the ICC's International Building Code.
 - 2. ICC-ES evaluation report for fastener.
- D. Coordinate wall sheathing installation with flashing and joint-sealant installation so these materials are installed in sequence and manner that prevent exterior moisture from passing through completed assembly.
- E. Do not bridge building expansion joints; cut and space edges of panels to match spacing of structural support elements.

3.2 WOOD STRUCTURAL PANEL INSTALLATION

- A. General: Comply with applicable recommendations in APA Form No. E30, "Engineered Wood Construction Guide," for types of structural-use panels and applications indicated.
- B. Fastening Methods: Fasten panels as indicated below:
 - 1. Subflooring: See Structural drawings for requirements.
 - 2. Wall and Roof Sheathing: See Structural drawings for requirements.
 - 3. Underlayment: See Structural drawings for requirements.

3.3 GYPSUM SHEATHING INSTALLATION

- A. Comply with GA-253 and with manufacturer's written instructions.

**KOPACHUCK STATE PARK
DAY USE DEVELOPMENT**

3.4 CEMENTITIOUS BACKER UNIT INSTALLATION

- A. Install panels and treat joints according to ANSI A108.11 and manufacturer's written instructions for type of application indicated.

END OF SECTION 061600

**KOPACHUCK STATE PARK
DAY USE DEVELOPMENT**

SECTION 061800 – GLUED-LAMINATED CONSTRUCTION

PART 1 – GENERAL

1.1 SECTION INCLUDES

- A. Section includes framing using structural glued-laminated timber.
- B. Related Requirements:
 - 1. Section 061000 "Rough Carpentry" for dimension lumber items associated with structural glued-laminated timber.

1.2 DEFINITIONS

- A. Structural Glued-Laminated (Glulam) Timber: An engineered, stress-rated timber product assembled from selected and prepared wood laminations bonded together with adhesives and with the grain of the laminations approximately parallel longitudinally.

1.3 ACTION SUBMITTALS

- A. Product Data: For each type of product.
 - 1. Include data on lumber, adhesives, fabrication, and protection.
 - 2. For preservative-treated wood products. Include chemical treatment manufacturer's written instructions for handling, storing, installing, and finishing treated material.
 - 3. For connectors. Include installation instructions.
- B. Shop Drawings:
 - 1. Show layout of structural glued-laminated timber system and full dimensions of each member.
 - 2. Include large-scale details of connections.

1.4 INFORMATIONAL SUBMITTALS

- A. Certificates of Conformance: Issued by a qualified testing and inspecting agency indicating that structural glued-laminated timber complies with requirements in AITC A190.1.
- B. Material Certificates: For preservative-treated wood products, from manufacturer. Indicate type of preservative used and net amount of preservative retained.

**KOPACHUCK STATE PARK
DAY USE DEVELOPMENT**

1.5 QUALITY ASSURANCE

- A. Manufacturer Qualifications: An AITC- or APA-EWS-licensed firm.

1.6 DELIVERY, STORAGE, AND HANDLING

- A. General: Comply with provisions in AITC 111.
- B. Individually wrap members using plastic-coated paper covering with water-resistant seams.

PART 2 – PRODUCTS

2.1 STRUCTURAL GLUED-LAMINATED TIMBER

- A. General: Provide structural glued-laminated timber that complies with AITC A190.1 and AITC 117 or research/evaluation reports acceptable to authorities having jurisdiction.
 - 1. Factory mark each piece of structural glued-laminated timber with AITC Quality Mark or APA-EWS trademark. Place mark on surfaces that are not exposed in the completed Work.
 - 2. Provide structural glued-laminated timber made from single species.
 - 3. Provide structural glued-laminated timber made from solid lumber laminations; do not use laminated veneer lumber.
 - 4. Provide structural glued-laminated timber made with wet-use adhesive complying with AITC A190.1.
 - 5. Adhesive shall not contain urea-formaldehyde resins.
 - 6. Adhesives shall comply with the testing and product requirements of the California Department of Public Health's (formerly, the California Department of Health Services') "Standard Method for the Testing and Evaluation of Volatile Organic Chemical Emissions from Indoor Sources Using Environmental Chambers."
- B. Species and Grades for Structural Glued-Laminated Timber: See Structural General Notes.
- C. Appearance Grade: Architectural, complying with AITC 110.
 - 1. For Premium and Architectural appearance grades, fill voids as required by AITC 110.

**KOPACHUCK STATE PARK
DAY USE DEVELOPMENT**

2.2 PRESERVATIVE TREATMENT

- A. Preservative Treatment: Where preservative-treated structural glued-laminated timber is indicated, comply with AWWA U1, Use Category 3A.
 - 1. Use preservative solution without water repellents or substances that might interfere with application of indicated finishes.
 - 2. Do not incise structural glued-laminated timber or wood used to produce structural glued laminated timber.

- B. Preservative: One of the following:
 - 1. Oxide copper (copper-8-quinolinolate) in a light petroleum solvent.
 - 2. Pentachlorophenol in light petroleum solvent.
 - 3. Copper naphthenate in a light petroleum solvent.
 - 4. Ammoniacal zinc copper arsenate (ACZA) in a water solution.
 - 5. Chromated copper arsenate (CCA) in a water solution.
 - 6. Ammoniacal copper quat Type A (ACQ-C) in a water solution.
 - 7. Propiconazole tebuconazole imidacloprid (PTI) in a water emulsion.

- C. After dressing members, apply a copper naphthenate field-treatment preservative to comply with AWWA M4 to surfaces cut to a depth of more than 1/16 inch (1.5 mm).

2.3 TIMBER CONNECTORS

- A. Manufacturers: Subject to compliance with requirements, provide products by Simpson Strong-Tie Co., Inc.

- B. Hot-dip galvanize steel assemblies and fasteners after fabrication to comply with:
 - 1. ASTM A 123/A 123M or ASTM A 153/A 153M.

2.4 SEALER

- A. End Sealer: Manufacturer's standard, transparent, colorless wood sealer that is effective in retarding the transmission of moisture at cross-grain cuts and is compatible with indicated finish.

- B. Penetrating Sealer: Manufacturer's standard, transparent, penetrating wood sealer that is compatible with indicated finish.

**KOPACHUCK STATE PARK
DAY USE DEVELOPMENT**

2.5 FABRICATION

- A. Shop fabricate for connections to greatest extent possible, including cutting to length and drilling bolt holes.
 - 1. Dress exposed surfaces as needed to remove planing and surfacing marks.
- B. Camber: Fabricate horizontal and inclined members of less than 1:1 slope with either circular or parabolic camber equal to 1/500 of span.
- C. Where preservative-treated members are indicated, fabricate (cut, drill, surface, and sand) before treatment to greatest extent possible. Where fabrication must be done after treatment, apply a field-treatment preservative to comply with AWPA M4.
 - 1. Use inorganic boron (SBX) treatment for members not in contact with the ground and continuously protected from liquid water.
 - 2. Use copper naphthenate treatment for members in contact with the ground or not
 - 3. continuously protected from liquid water.
- D. End-Cut Sealing: Immediately after end cutting each member to final length and after preservative treatment, apply a saturation coat of end sealer to ends and other cross-cut surfaces, keeping surfaces flood coated for not less than 10 minutes.
- E. All beams and columns exposed to view shall be sanded.
- F. Seal Coat: After fabricating, sanding, and end-coat sealing, apply a heavy saturation coat of penetrating sealer on surfaces of each unit exposed to public view except for preservative treated wood where treatment included a water repellent. See Sealer specification section 2.4 above.

2.6 FACTORY FINISHING

- A. Sealer shall be applied in the factory as much as practical.

PART 3 – EXECUTION

3.1 EXAMINATION

- A. Examine substrates in areas to receive structural glued-laminated timber, with Installer present, for compliance with requirements, installation tolerances, and other conditions affecting performance of the Work.
- B. Proceed with installation only after unsatisfactory conditions have been corrected.

**KOPACHUCK STATE PARK
DAY USE DEVELOPMENT**

3.2 INSTALLATION

- A. General: Erect structural glued-laminated timber true and plumb and with uniform, close-fitting joints. Provide temporary bracing to maintain lines and levels until permanent supporting members are in place.
 - 1. Handle and temporarily support glued-laminated timber to prevent surface damage, compression, and other effects that might interfere with indicated finish.
- B. Cutting: Avoid extra cutting after fabrication. Where field fitting is unavoidable, comply with requirements for shop fabrication.
- C. Fit structural glued-laminated timber by cutting and restoring exposed surfaces to match specified surfacing and finishing.
 - 1. Predrill for fasteners using timber connectors as templates.
 - 2. Finish exposed surfaces to remove planing or surfacing marks and to provide a finish equivalent to that produced by machine sanding with No. 120 grit sandpaper.
 - 3. Coat cross cuts with end sealer.
 - 4. Where preservative-treated members must be cut during erection, apply a field-treatment preservative to comply with AWPA M4.
 - a Use inorganic boron (SBX) treatment for members not in contact with the ground and continuously protected from liquid water.
 - b Use copper naphthenate treatment for members in contact with the ground or not continuously protected from liquid water.
- D. Install timber connectors as indicated.
 - 1. Unless otherwise indicated, install bolts with same orientation within each connection and in similar connections.
 - 2. Install bolts with orientation as indicated or, if not indicated, as directed by Architect.

3.3 ADJUSTING

- A. Repair damaged surfaces and finishes after completing erection. Replace damaged structural glued-laminated timber if repairs are not approved by Architect.

**KOPACHUCK STATE PARK
DAY USE DEVELOPMENT**

3.4 PROTECTION

- A. Do not remove wrappings on individually wrapped members until they no longer serve a useful purpose, including protection from weather, sunlight, soiling, and damage from work of other trades.
 - 1. Coordinate wrapping removal with finishing work. Retain wrapping where it can serve as a painting shield.
 - 2. Slit underside of wrapping to prevent accumulation of moisture inside the wrapping.

END OF SECTION 061800

**KOPACHUCK STATE PARK
DAY USE DEVELOPMENT**

SECTION 062013 - EXTERIOR FINISH CARPENTRY

PART 1 - GENERAL

1.1 SUMMARY

A. Section Includes:

1. Plywood soffits.
2. Continuous soffit vents and round vents at blocking.

1.2 RELATED SECTIONS

1.3 Section Includes:

1. Section 074646 Fiber Cement Siding

1.4 SUBMITTALS

- A. Product Data: For each type of process and factory-fabricated product.
- B. Samples: For each exposed product and for each color and texture specified.

PART 2 - PRODUCTS

2.1 PLYWOOD SOFFITS

- A. Plywood Type: Exterior, APA Rated Siding 303, Species Group 1.
- B. Thickness: 1/2 inch
- C. Face Species: Western red cedar
- D. Pattern: Plain.
- E. Surface: Rough sawn.

2.2 MISCELLANEOUS MATERIALS

- A. Fasteners for Exterior Finish Carpentry: Provide nails or screws, in sufficient length to penetrate not less than 1-1/2 inches into wood substrate.

**KOPACHUCK STATE PARK
DAY USE DEVELOPMENT**

- B. Blocking: Provide blocking at all plywood edges. Leave 1/8" space at all panel end and edge joints.
- C. Continuous Soffit Vents: Aluminum hat channel shape with perforations, 2 inches wide and in lengths not less than 96 inches.
 - 1. Net-Free Area: 9 sq.in/lf.
 - 2. Finish: Mill finish.
- D. Round Vents at Blocking: Stamped aluminum louvered vents, 2 inches in diameter, made to be inserted in round holes cut in 2x blocking. Provide (3) vents per joist space.
 - 1. Finish: Mill finish.

END OF SECTION 062013

**KOPACHUCK STATE PARK
DAY USE DEVELOPMENT**

SECTION 062023 - INTERIOR FINISH CARPENTRY

PART 1 - GENERAL

1.1 SUMMARY

- A. Section Includes:
1. Interior standing and running trim.
 2. Interior plywood paneling with batten boards.
 3. Wood window sills with opaque finish
 4. Wall mounted shelving.
 5. Free standing steel shelving.

1.2 ACTION SUBMITTALS

- A. Product Data: For each type of process and factory-fabricated product.

PART 2 - PRODUCTS

2.1 MATERIALS, GENERAL

- A. Lumber: DOC PS 20 and applicable rules of grading agencies indicated. If no grading agency is indicated, comply with applicable rules of any rules-writing agency certified by the American Lumber Standard Committee's (ALSC) Board of Review. Grade lumber by an agency certified by the ALSC's Board of Review to inspect and grade lumber under the rules indicated.
1. Omit grade stamp and provide certificates of grade compliance issued by grading agency.
- B. Softwood Plywood: DOC PS 1.

2.2 INTERIOR TRIM

- A. Lumber Trim for Opaque Finish (Painted Finish)
1. Species and Grade: Birch, Doug-fir, hemlock, poplar, or alder, Finish or 1 Common NELMA or NLGA.
 2. Maximum Moisture Content: 15 percent.
 3. Finger Joining: Allowed.
 4. Face Surface: Surfaced (smooth).

**KOPACHUCK STATE PARK
DAY USE DEVELOPMENT**

2.3 INTERIOR PLYWOOD PANELING WITH BATTEN BOARDS

- A. Plywood Type: APA-rated siding in panel sizes indicated.
- B. Thickness: ½”.
- C. Face Species: Douglas Fir.
- D. Pattern: Plain.
- E. Surface: Rough sawn.
- F. Board and Batten: 1x3 cedar; C and Better Clear.

2.4 WALL MOUNTED SHELVING

- A. Adjustable Wall-Mounted Shelving
 - 1. Grade: “Custom Grade”, per AWS.
 - 2. Material:
 - 1. Plastic laminate faces.
 - 3. Conform to AWS Section 10-Appendix B for shelf deflection.
- B. Adjustable Wall-Mounted Metal Shelf Standards and Brackets: Knape and Vogt No. 87 Series Standard and 186/187 Series Bracket System; ANO (anochrome) finish, 12 gauge, 18 inches deep.

2.5 FREE STANDING STEEL SHELVING

- A. Free standing steel shelving: Omega Precision Wire Shelving, 12” deep x 60” wide x 74” high, 4-tier chrome starter shelving unit.

2.6 MISCELLANEOUS MATERIALS

- A. Fasteners: Nails, screws, and other anchoring devices of type, size, material, and finish required for application indicated to provide secure attachment, concealed where possible.
- B. Wood Filler: Oil base filler, color to match wood being filled.
- C. Miscellaneous: Blocking for In-Wall support: Wood blocking for anchorage of architectural woodwork to walls where required for complete, secured installation.

**KOPACHUCK STATE PARK
DAY USE DEVELOPMENT**

PART 3 - EXECUTION

3.1 PREPARATION

- A. Clean substrates of projections and substances detrimental to application.
- B. Before installing interior finish carpentry, condition materials to average prevailing humidity in installation areas for a minimum of 24 hours.

3.2 INSTALLATION, GENERAL

- A. Install interior finish carpentry level, plumb, true, and aligned with adjacent materials.
 - 1. Use concealed shims where necessary for alignment.
 - 2. Scribe and cut interior finish carpentry to fit adjoining work. Refinish and seal cuts as recommended by manufacturer.
 - 3. Where face fastening is unavoidable, countersink fasteners, fill surface flush, and sand unless otherwise indicated.
 - 4. Install to tolerance of 1/8 inch in 96 inches for level and plumb. Install adjoining interior finish carpentry with 1/32-inch maximum offset for flush installation and 1/16-inch maximum offset for reveal installation.
 - 5. Coordinate interior finish carpentry with materials and systems in or adjacent to it. Provide cutouts for mechanical and electrical items that penetrate interior finish carpentry.

3.3 INSTALLATION OF STANDING AND RUNNING TRIM

- A. Install trim with minimum number of joints as is practical, using full-length pieces from maximum lengths of lumber available.
 - 1. Do not use pieces less than 24 inches long, except where necessary.
 - 2. Stagger joints in adjacent and related standing and running trim.
 - 3. Miter at returns, miter at outside corners, and cope at inside corners to produce tight-fitting joints with full-surface contact throughout length of joint.
 - 4. Use scarf joints for end-to-end joints.
 - 5. Plane backs of casings to provide uniform thickness across joints where necessary for alignment.
 - 6. Install without splitting; drill pilot holes before fastening where necessary to prevent splitting.
 - 7. Fasten to prevent movement or warping.
 - 8. Countersink fastener heads on exposed carpentry work and fill holes.

**KOPACHUCK STATE PARK
DAY USE DEVELOPMENT**

3.4 INSTALLATION OF PLYWOOD PANELING

- A. Plywood Paneling: Select and arrange panels on each wall to minimize noticeable variations in grain character and color between adjacent panels.
1. Leave 1/4-inch gap to be covered with trim at top, bottom, and openings.
 2. Install with uniform tight joints between panels.
 3. Attach panels to supports with manufacturer's recommended panel adhesive and fasteners.
 4. Space fasteners and adhesive as recommended by panel manufacturer.
 5. Conceal fasteners to greatest practical extent.
 6. Install batten boards at 16" on center.

END OF SECTION 062023

**KOPACHUCK STATE PARK
DAY USE DEVELOPMENT**

SECTION 064116 - PLASTIC-LAMINATE-CLAD ARCHITECTURAL CABINETS

PART 1 - GENERAL

1.1 SUMMARY

- A. Section Includes:
 - 1. Specialty fabricated cabinet units.
 - 2. Countertops.
 - 3. Cabinet hardware.

1.2 ACTION SUBMITTALS

- A. Product Data: For each type of product.
- B. Shop Drawings:
 - 1. Include plans, elevations, sections, and attachment details.
- C. Samples: For each exposed product and for each color and texture specified.

1.3 QUALITY ASSURANCE

- A. Manufacturer's Qualifications: Company specializing in fabricating the products specified in this section with minimum five years of documented experience.

1.4 DELIVERY, STORAGE, AND HANDLING

- A. Protect units from moisture damage.

PART 2 - PRODUCTS

2.1 ARCHITECTURAL CABINET MANUFACTURERS

- A. Manufacturers: Subject to compliance with requirements, provide products by:
- B. Vrieze & Olson Custom Woodworking, 2313 E. Pioneer, Puyallup, WA;(253) 445-9733.
- C. Genothen Holdings, LLC, 2948 29th Ave. SW, Tumwater, WA: (360) 352-3636.
- D. Or approved equal.

**KOPACHUCK STATE PARK
DAY USE DEVELOPMENT**

2.2 PLASTIC-LAMINATE-CLAD ARCHITECTURAL CABINETS

- A. Quality Grade: Unless otherwise indicated, provide products of quality specified by AWI/AWMAC/WI (AWS) for Custom Grade.
- B. Plastic Laminate Faced Cabinets: Custom Grade.

2.3 WOOD-BASED COMPONENTS

- A. Wood fabricated from old growth timber is not permitted.

2.4 COUNTERTOPS

- A. Plastic Laminate Countertops: Medium density fiberboard substrate covered with HPDL, conventionally fabricated, with decorative 3mm PVC edge.

2.5 ACCESSORIES

- A. Adhesive: Type recommended by fabricator to suit application.
- B. Fasteners: Size and type to suit application.
- C. Bolts, Nuts, Washers, Lags, Pins, and Screws: Of size and type to suit application.
- D. Concealed Joint Fasteners: Threaded steel.

2.6 HARDWARE

- A. Door and Drawer Pulls: Semi-recessed elliptical design made of ABS plastic.
- B. Drawer Slides: Single extension, 100 lb. load rating. Positive in and out stops, stay close detent, one side captive and four nylon rollers.
- C. Adjustable Shelf Support System: Nickel plated steel "L" shaped clips with security pin to prevent shelf from inadvertent removal, to be inserted in predrilled 5 mm diameter holes 32mm on centers.
- D. Cabinet Locks: Dead bolt type, constructed with solid brass cylinder and five pin tumblers. Exposed finish US26D satin chrome.
 - 1. Doors: CompX #C8173-26D
 - 2. Drawers: CompX #C8179-26D
- E. Wire Grommets: Provide with removable and adjustable caps, black. Size 65mm diameter. Allow for grommets to be installed at 36 inch intervals on all wood surface countertops, subject to direction by Architect.
- F. Catches: Magnetic, 7 lb. pull rating.

**KOPACHUCK STATE PARK
DAY USE DEVELOPMENT**

- G. Hinges: Five knuckle, radius tips 2-3/4"x0.095" fastened with 4 screws to end panel and 5 screws to door panel with door opening of 270 degrees. Black finish.
- H. Support Brackets: Constructed of 15 gauge 1-1/2 inch tube steel, with welded construction, designed to support countertops off finished wall at desired heights. Powder coat finish.

2.7 FABRICATION

- A. Assembly: Shop assemble cabinets for delivery to site in units easily handled and to permit passage through building openings.
- B. Provide full depth security panel between drawers when individual drawer locking is required.
- C. Countertops:
 - 1. Laminate countertops shall be GP50 NEMA grade laminate with 0.020 inch backing sheet bonded to 3/4 inch substrate.
 - 2. Finished edge shall be trimmed with 3mm PVC applied after the top surface. Overall thickness 1 1/2 inch, with build-up added to the substrate.
 - a. Product: Dollken Edgebanding; www.na.doellken.com
 - b. Color: Selected from manufacturer's standard colors.
 - 3. Backsplashes shall be 3/4 inch and 4 inches high, unless noted otherwise. Material and color shall be the same as countertop deck. Backsplashes shall be factory assembled with waterproof sealant and #6 x 2 inch screws at 6 inches on center.
 - 4. Countertops shall be furnished in longest possible lengths. When joints are required they shall be factory prepared with a minimum of four 1/4 inch joint bolts each. Joints shall be field assembled with waterproof sealant to insure stable and rigid construction. No joints allowed within 24 inches of sinks, counter ends, or knee space areas.
 - 5. Reveal overlay style with 3mm edgebanding.
 - 6. Adhesive for Bonding Edges: Hot melt adhesive.

PART 3-EXECUTION

3.1 EXAMINATION

- A. Verify adequacy of backing and support system.
- B. Use fixture attachments in concealed locations for wall mounted components.
- C. Use concealed joint fasteners to align and secure adjoining cabinet units.
- D. Carefully scribe casework abutting other components, with maximum gaps of 1/32 inch. Do not use additional overlay trim for this purpose.
- E. Secure cabinets and count bases to floor using appropriate angles and anchorages.

**KOPACHUCK STATE PARK
DAY USE DEVELOPMENT**

3.2 ADJUSTING

- A. Adjust installed work.
- B. Adjust moving or operating parts to function smoothly and correctly.

3.3 CLEANING

- A. Clean casework, counters, shelves, hardware, fittings, and fixtures.

END OF SECTION 064116

**KOPACHUCK STATE PARK
DAY USE DEVELOPMENT**

SECTION 067300 – COMPOSITE DECKING

PART 1 GENERAL

1.1 SECTION INCLUDES

- A. Composite Decking (Trex Select).

1.2 REFERENCES

- A. ASTM International (ASTM):
 1. ASTM C177: Standard Test Method for Steady-State Heat Flux Measurements and Thermal Transmission Properties by Means of the Guarded-Hot-Plate Apparatus
 2. ASTM D570: Water Absorption of Plastics.
 3. ASTM D1761: Mechanical Fasteners in Wood
 4. ASTM D1413: Test method for Wood Preservatives by Laboratory Soil-block Cultures
 5. ASTM D7031: Standard Guide for Evaluating Mechanical and Physical Properties of Wood-Plastic Composite Products, ASTM International
 6. ASTM D7032: Standard Specification for Establishing Performance Ratings for Wood-Plastic Composite Deck Boards and Guardrail Systems (Guards or Handrails).
 7. ASTM E84: Test Method for Surface Burning Characteristics of Building Materials, ASTM International.

1.3 SUBMITTALS

- A. Product Data: Manufacturer's data sheets on each product to be used, including:
 1. Preparation instructions and recommendations.
 2. Storage and handling requirements and recommendations.
 3. Installation methods.
- B. Shop Drawings:
 1. Provide plans and details which include layout, spacing, and sizes of decking and railings.
- C. Selection Samples: For each finish product specified, two complete sets of color chips representing manufacturer's full range of available colors and patterns.
- D. Verification Samples: For each finish product specified, two samples, representing actual product color, size, and finish.

1.4 QUALITY ASSURANCE

- A. Manufacturer Qualifications: Minimum 5 year experience manufacturing similar products.

**KOPACHUCK STATE PARK
DAY USE DEVELOPMENT**

- B. Installer Qualifications: Minimum 2 year experience installing similar products.
 - 1. Mock-Up: Provide a mock-up for evaluation of surface preparation techniques and application workmanship.
 - a. Finish areas designated by Architect.
 - b. Do not proceed with remaining work until workmanship is approved by Architect.
 - c. Refinish mock-up area as required to produce acceptable work.

1.5 PRE-INSTALLATION MEETINGS

- A. Convene minimum two weeks prior to starting work of this section.

1.6 DELIVERY, STORAGE, AND HANDLING

- A. Deliver and store products in manufacturer's unopened packaging bearing the brand name and manufacturer's identification until ready for installation.
- B. Store products on a flat and level surface. Adjust support blocks accordingly.
- C. Support bundles on supplied dunnage.
- D. When stacking bundles, supports should start approximately 8 inches from each end and be spaced approximately 2 feet on center. Supports shall line up vertically/perpendicular to the decking product.
- E. Do not stack decking more than 14 bundles.
- F. Keep material covered using the provided bundle cover until time of installation.
- G. Handle materials to avoid damage.

1.7 PROJECT CONDITIONS

- A. Maintain environmental conditions (temperature, humidity, and ventilation) within limits recommended by manufacturer for optimum results. Do not install products under environmental conditions outside manufacturer's recommended limits.

1.8 SEQUENCING

- A. Ensure that products of this section are supplied to affected trades in time to prevent interruption of construction progress.

**KOPACHUCK STATE PARK
DAY USE DEVELOPMENT**

1.9 WARRANTY

- A. Provide manufacturer's warranty against rot, decay, splitting, checking, splintering, fungal damage, and termite damage for a period of 10 years for a commercial installation. In addition provide the Trex Fade and Stain Warranty against food staining and fading beyond 5 Delta E (CIE units) for a period of 10 years for a commercial installation.

PART 2 – PRODUCTS

2.1 MANUFACTURERS

- A. Acceptable Manufacturer: Trex Company, Inc., 160 Exeter Dr.; Winchester, VA 22603-8605; Toll Free Tel: 800-BUY-TREX; Tel: 540-542-6300; Fax: 540-542-6890; Email: [request info \(marketing@trex.com\)](mailto:request_info@marketing@trex.com); Web: <https://www.trex.com>
- B. Requests for substitutions will be considered in accordance with provisions of Section 01 60 00 - Product Requirements.

2.2 DESIGN/PERFORMANCE REQUIREMENTS:

- A. Structural Performance:
 - 1. Deck: Uniform Load - 100lb/sq.ft.
 - 2. Tread of Stairs: Concentrated Load: 750 lb/sq.ft., and 1/8 inch maximum deflection with a concentrated load of 300 lbf on area of 4 sq. in.
- B. Fire-Surface Burning Characteristics per ASTM E-84.

2.3 COMPOSITE DECKING

- A. Wood-Plastic Composite Lumber:
 - 1. Product: Trex Select as manufactured by Trex Railing and Decking.
 - 2. Pattern: Consistent patterns board to board reveal a flawless finish.
 - 3. Material Description: Composite Decking consisting of recycled Linear Low Density Polyethylene (LLDPE) and recycled wood. The product is extruded into shapes and sizes as follows:
 - a. Trex Select Decking Boards; 0.875 inches x 5.5 inches (22 mm x 140 mm).
 - b. Lengths : 12 feet (3658 mm) 16 feet (4877 mm), and 20 feet (6096 mm).
 - c. Color : To be selected by owner from Trex' standard list of colors.
 - 4. Physical and Mechanical Properties as follows:
 - a. Flame Spread, ASTM E 84: 85.
 - b. Thermal Expansion, ASTM D 1037: 1.9 x 10⁻⁵ inch/inch/degree F.

**KOPACHUCK STATE PARK
DAY USE DEVELOPMENT**

- c. Moisture Absorption, ASTM D 1037: Less than 1.2%.
- d. Screw Withdrawal, ASTM D1761: 388 lbs/in.
- e. Fungus Resistance, ASTM D1413: Rating - no decay.
- f. Termite Resistance, AWPAE1-72: Rating = 9.7.
- g. Compression Parallel, ASTM D198: 1588 psi ultimate, 540 psi design.
- h. Compression Perpendicular, ASTM D143: 1437 psi ultimate, 540 psi design.
- i. Bending Strength, ASTM D198: 3280 psi ultimate, 500 psi design.
- j. Shear Strength, ASTM D143: 1761 psi ultimate, 360 psi design.
- k. Modulus of Elasticity, ASTM D4761: 400,000psi ultimate, 200,000 psi design.
- l. Modulus of Rupture, ASTM D4761: 3750 psi ultimate, 500 psi design.
- m. Ultimate strength values are not meant for design analysis. Design values are for temperatures up to 130 degree F (54 degree C).

B. Accessory Hardware:

1. Fasteners:

- a. Trex Universal Hideaway Hidden Fasteners.

PART 3 EXECUTION

3.1 EXAMINATION

- A. Do not begin installation until substrates have been properly prepared.
- B. If substrate preparation is the responsibility of another installer, notify Architect of unsatisfactory preparation before proceeding.

3.2 PREPARATION

- A. Clean surfaces thoroughly prior to installation.
- B. Prepare surfaces using the methods recommended by the manufacturer for achieving the best result for the substrate under the project conditions.

3.3 INSTALLATION

- A. Install in accordance with manufacturer's instructions, approved submittals, and in proper relationship with adjacent construction.
- B. Cut, drill, and rout using carbide tipped blades.
- C. Do not use composite wood material for structural applications.

3.4 CLEANING

- A. Cleaning as required by manufacturer for warranty compliance.

**KOPACHUCK STATE PARK
DAY USE DEVELOPMENT**

3.5 PROTECTION

- A. Protect installed products until completion of project.
- B. Touch-up, repair or replace damaged products before Substantial Completion.

END OF SECTION 067300

**KOPACHUCK STATE PARK
DAY USE DEVELOPMENT**

SECTION 072100-INSULATION

PART 1 - GENERAL

1.1 SUMMARY

A. Section Includes:

1. Insulation at Perimeter of Foundation: Extruded polystyrene board.
2. Insulation at Wood Framed Walls, Floors, and Roof: Batt insulation with separate vapor retarder.
3. Sound Attenuation Batt Insulation at interior walls.
4. Foamed-In-Place Insulation.

1.2 ACTION SUBMITTALS

- A. Product Data: Provide data on product characteristics, performance criteria, and product limitations.

1.3 INFORMATIONAL SUBMITTALS

- A. Installer's Certification: Listing type, manufacturer, and R-value of insulation installed in each element of the building thermal envelope.
1. Sign, date, and post the certification in a conspicuous location on Project site.
- B. Product test reports.
- C. Research reports.

PART 2 - PRODUCTS

2.1 EXTRUDED POLYSTYRENE BOARD INSULATION

- A. Extruded Polystyrene Board Insulation, Type X: ASTM C578, unfaced.

1. Manufacturers:
 - a. Owens Corning Corporation; FOAMULAR Extruded Polystyrene (XPS) Insulation, www.ocbuildingspec.com or approved equal.
2. Smoke-Developed Index: Not more than 450 when tested in accordance with ASTM E84.
3. Labeling: Provide identification of mark indicating R-value of each piece of insulation 12 inches and wider in width.
4. Board Size: 24 x 96 inch.
5. Thermal Resistance: R-value of 10.

**KOPACHUCK STATE PARK
DAY USE DEVELOPMENT**

6. Board Edges: Square.
7. Compressive Resistance: 25 psi.
8. Board Density: 1.6 lb/cu. Ft.

2.2 BATT INSULATION MATERIALS

- A. Glass-Fiber Blanket Insulation, Unfaced, ASTM C665, Type I; passing ASTM E136 for combustion characteristics.
 1. Manufacturers:
 - a. CertainTeed Corporation, www.certainteed.com
 - b. Johns Manville; www.jm.com
 - c. Owens Corning; www.owenscorning.com
 2. Combustibility: Non-combustible, when tested in accordance with ASTM E136 C665; friction fit
 3. Thermal Resistance: R-49 at roofs; R-21 at exterior walls; R-30 at Day Use Building floor.
 4. Thickness: As required to meet thermal resistance specified.
 5. Labeling: Provide identification of mark indicating R-value of each piece of insulation 12 inches and wider in width.

2.3 SOUND ATTENUATION BATT INSULATION

- A. Sound Attenuation Batt Insulation: ASTM C 665; preformed glass fiber batt; friction fit, conforming to the following:
 1. Thickness: 3-1/2 inch
 2. Facing: Unfaced.
 3. Manufacturers:
 - a. CertainTeed Corp.
 - b. John Mansville.
 - c. Owens Corning Corp.

2.4 FOAMED-IN-PLACE INSULATION

- A. Low-density, closed cell, water vapor permeable polyurethane foam; foamed on-site, using blowing agent of water or non-ozone-depleting gas.
 1. Manufacturers:
 - a. BASF Corporation
 - b. Gaco Western
 - c. Henry Company
 2. Thermal Resistance: R-6.125 per inch minimum.

**KOPACHUCK STATE PARK
DAY USE DEVELOPMENT**

2.5 ACCESSORIES

- A. Insulation Anchors, Spindles, and Standoffs: As recommended by manufacturer.
- B. Adhesive for Bonding Insulation: Product compatible with insulation and air and water barrier materials, and with demonstrated capability to bond insulation securely to substrates without damaging insulation and substrates.
- C. Eave Ventilation Troughs: Preformed, rigid fiberboard or plastic sheets designed and sized to fit between roof framing members and to provide ventilation between insulated attic spaces and vented eaves.
- D. Sheet Vapor Retarder: Intello Plus intelligent vapor retarder 16 mil by Pro Clima.
 - 1. Manufacturer: Pro Clima/Moll bauökologische Produkte GmbH, 68723 Schwetzingen Germany. Imported by 475 High Performance Building Supply, 334 Douglass street, Brooklyn NY,
 - 2. Tel: 718-622-1600; Email; info@foursevenfive.com; Web: www.foursevenfive.com / www.foursevenfive.ca
- E. Vapor Retarder Tape: Tescon Vana solid acrylic tape by Pro Clima at seams and penetrations of liner.
 - 1. Manufacturer: Pro Clima/Moll bauökologische Produkte GmbH, 68723 Schwetzingen Germany. Imported by 475 High Performance Building Supply, 334 Douglass street, Brooklyn NY,
 - 2. Tel: 718-622-1600; Email; info@foursevenfive.com; Web: www.foursevenfive.com / www.foursevenfive.ca
- F. Crawl Space Vapor Retarder: StegoCrawl Wrap 15mil vapor barrier by Stego Industries LLC. Provide StegoCrawl Tape at seams and penetrations of liner. Provide StegoCrawl Term Bar and Stego Tack Tape (double sided) at perimeter/edge seal.
 - a. Stego Industries LLC., (877) 464-7834 www.stegoindustries.com.

PART 3 - EXECUTION

3.1 INSTALLATION, GENERAL

- A. Comply with insulation manufacturer's written instructions applicable to products and applications.
- B. Install insulation that is undamaged, dry, and unsoiled and that has not been left exposed to ice, rain, or snow at any time.
- C. Install insulation with manufacturer's R-value label exposed after insulation is installed.
- D. Extend insulation to envelop entire area to be insulated. Fit tightly around obstructions and fill voids with insulation. Remove projections that interfere with placement.

**KOPACHUCK STATE PARK
DAY USE DEVELOPMENT**

- E. Provide sizes to fit applications and selected from manufacturer's standard thicknesses, widths, and lengths. Apply single layer of insulation units unless multiple layers are otherwise shown or required to make up total thickness or to achieve R-value.

3.2 INSTALLATION OF FOUNDATION WALL INSULATION.

- A. Butt panels together for tight fit.
- B. Adhesive Installation: Install with adhesive according to manufacturer's written instructions.

3.3 INSTALLATION OF INSULATION IN FRAMED CONSTRUCTION

- A. Blanket Insulation: Install in cavities formed by framing members according to the following requirements:
 - 1. Use insulation widths and lengths that fill the cavities formed by framing members. If more than one length is required to fill the cavities, provide lengths that will produce a snug fit between ends.
 - 2. Place insulation in cavities formed by framing members to produce a friction fit between edges of insulation and adjoining framing members.
 - 3. Attics: Install eave ventilation troughs between roof framing members in insulated attic spaces at vented eaves.
- B. Miscellaneous Voids: Install insulation in miscellaneous voids and cavity spaces where required to prevent gaps in insulation using the following materials:
 - 1. Glass-Fiber Insulation: Compact to approximately 40 percent of normal maximum volume equaling a density of approximately 2.5 lb/cu. ft.

3.4 INSTALLATION OF VAPOR RETARDERS

- A. General: Extend vapor retarder to extremities of areas to be protected from vapor transmission. Secure in place with adhesives or other anchorage system as indicated. Extend vapor retarder to cover miscellaneous voids in insulated substrates.
- B. Seal joints caused by pipes, conduits, electrical boxes, and similar items penetrating vapor retarders with vapor retarder tape to create an air tight seal between penetrating objects and vapor retarder.
- C. Repair tears or punctures in vapor retarders immediately before concealment by other work. Cover with vapor retarder tape or another layer of vapor retarder.
- D. Vapor Retarder in Crawl Space: Install vapor retarder over grade in crawlspace. Lap 12 inches and tape all edges. Turn up edges and secure to foundations or footings. Fix and seal around pipes, conduits, and posts with the "Boot" , a pressure sensitive rubber sheet.

**KOPACHUCK STATE PARK
DAY USE DEVELOPMENT**

3.5 INSTALLATION OF SOUND ATTENUATION BATT INSULATION

- A. Friction fit sound attenuation blanket between studs. Provide 3-1/2" thick at 2x4 walls and 5-1/2" thick at 2x6 walls.
 - 1. Provide sound attenuation batt insulation at **all interior walls**.

END OF SECTION 072100

**KOPACHUCK STATE PARK
DAY USE DEVELOPMENT**

SECTION 072500 - WEATHER BARRIERS

PART 1 - GENERAL

1.1 SUMMARY

A. Section Includes:

1. Water-Resistive Barrier: Under exterior wall cladding, over sheathing or other substrate; not air tight or vapor retardant.
2. Vapor Retarders: Materials to make exterior walls, joints between exterior walls and roof, and joints around frames of openings in exterior walls water vapor resistant and air tight.
3. Air Barriers: Materials that form a system to stop passage of air through exterior walls and joints around frames of openings in exterior walls.
4. Crawl Space: Vapor Retarder at Day Use Building.

1.2 RELATED REQUIREMENTS

- A. Section 033000-Cast-in-Place Concrete: Vapor retarder under concrete slabs on grade.
- B. Section 072100-Insulation: Vapor retarder installed in conjunction with batt insulation.
- C. Section 079200-Joints Sealants: Sealing building expansion joints.
- D. Section 092116- Gypsum Board Assemblies: Water-resistive barrier under exterior cladding.

1.3 DEFINITIONS

- A. Weather Barrier: Assemblies that form either water-resistive barriers, air barriers, or vapor barriers.
- B. Air Barrier: Air tight barrier made of material that is relatively air impermeable but water vapor permeable, both to the degree specified, with sealed seams and with sealed joints to adjacent surfaces. Note: For the purposes of this specification, vapor impermeable air barriers are classified as vapor retarders.
- C. Vapor Retarder: Air tight barrier made of material that is relatively water vapor impermeable, to the degree specified, with sealed seams and with sealed joints to adjacent surfaces.
 1. Water Vapor Permeance: For purposes of conversion, $57.2 \text{ ng}/(\text{Pa s sq m})=1 \text{ perm.}$

**KOPACHUCK STATE PARK
DAY USE DEVELOPMENT**

1.4 REFERENCE STANDARDS

- A. AATCC Test Method 127-Water Resistance: Hydrostatic Pressure Test, 2014.
- B. ASTM D 4397- Standard Specification for Polyethylene for Construction, Industrial, and Agricultural Applications, 2010.
- C. ASTM E84- Standard Test Methods for Surface Burning Characteristics of Building Materials, 2015A
- D. ASTM E96/E96M- Standard Test Method for Water Vapor Transmission of Materials; 2014.
- E. ASTM E1745 – 17 Standard Specification for Plastic Water Vapor Retarders Used in Contact with Soil or Granular Fill Under Concrete Slabs.
- F. ASTM E2178- Standard Test Method for Air Permeance of Building Materials; 2013.
- G. ICC-ES AC308- Acceptance Criteria for Water-Resistive Barriers; ICC Evaluation Service, Inc; 2013.
- H. ISO 12572- Hygrothermal performance of building materials and products.

1.5 SUBMITTALS

- A. Product Data: Provide data on material characteristics.
- B. Manufacturer's Installation Instructions: Indicate preparation, installation methods, and storage and handling criteria.

1.6 FIELD CONDITIONS

- A. Maintain temperature and humidity recommended by the materials manufacturers before, during, and after installation.

PART 2 - PRODUCTS

2.1 WEATHER BARRIER ASSEMBLIES

- A. Water-Resistive Barrier: Provide on exterior walls under exterior cladding and where indicated in other sections.
- B. Interior Vapor Retarder:
 - 1. On inside face of studs of exterior walls, under cladding, use mechanically fastened vapor retarder sheet.

**KOPACHUCK STATE PARK
DAY USE DEVELOPMENT**

2.2 AIR BARRIER MATERIALS (WATER VAPOR PERMEABLE AND WATER-RESISTIVE)

A. Air Barrier Sheets, Mechanically Fastened:

1. Air Permeance: 0.0019 cubic feet per minute per square foot, maximum, when tested in accordance with ASTM E2178.
2. Water Vapor Permeance: 5 perms, minimum, when tested in accordance with ASTM E96/E96M Procedure A (desiccant procedure).
3. Ultraviolet and Weathering Resistance: Approved in writing by manufacturer for minimum of 180 days weather exposure.
4. Surface Burning Characteristics: Flame spread index of 25 or less, and smoke developed index of 50 or less, when tested in accordance with ASTM E84.
5. Seam and Perimeter Tape: Polyethylene self adhering type, mesh reinforced, 2 inches wide, compatible with sheet material; unless otherwise specified.
6. Products:
 - a. DuPont Building Innovations: Tyvek Commercial Wrap with Tyvek Fluid Applied Flashing-Brush Formulation, Tyvek Fluid Applied Flashing and Joint Compound, FlexWrap NF, StraightFlash, StraightFlash VF, Tyvek Wrap Caps, and Tyvek Tape: www.dupont.com

2.3 VAPOR RETARDER MATERIALS (AIR BARRIER AND WATER-RESISTIVE)

A. Vapor Retarder Sheet: ASTM D4397 polyethylene film reinforced with glass fiber square mesh, clear.

1. Thickness: 16 mil.
2. Water Vapor Permeance: As required by referenced standard for thickness specified.
3. Seam and Perimeter Tape: Polyethylene self adhering type, mesh reinforced, 2 inches wide, compatible with sheet material.

2.4 SEALANTS

A. Sealant shall be compatible with sheet membrane, as recommended by membrane manufacturer.

B. Silicone Sealant: ASTM C920, Grade NS, Class 25, Uses NT, A, G, M; single component, neutral curing, non-sagging, non-staining, non-bleeding.

1. Dow Corning Corporation: 758, www.dowcorning.com

C. Primers, Cleaners, and Other Sealant Materials: As recommended by sealant manufacturer, appropriate to application, and compatible with adjacent materials.

2.5 TRANSITION AND FLASHING MEMBRANES

A. Per membrane manufacturer recommendations.

**KOPACHUCK STATE PARK
DAY USE DEVELOPMENT**

2.6 CRAWL SPACE VAPOR RETARDER

- A. Reinforced Polyethylene Vapor Barrier: Sheet with outer layers of polyethylene film laminated to an inner reinforcing layer consisting of either nylon cord or polyester scrim and weighing not less than 20 lb/1000 sq. ft., with maximum permeance rating of 0.1 perm; Class A.

PART 3 - EXECUTION

3.1 EXAMINATION

- A. Verify that surfaces and conditions are ready to accept the work of this section.

3.2 PREPARATION

- A. Remove loose or foreign matter which might impair application of materials.

3.3 INSTALLATION

- A. Install materials in accordance with manufacturer's instructions.
- B. Air Barriers: Install continuous air tight barrier over surfaces indicated, with sealed seams and with sealed joints to adjacent surfaces.
- C. Vapor Retarders: Install continuous air tight barrier over surfaces indicated, with sealed seams and with sealed joints to adjacent surfaces.
- D. Mechanically Fastened Sheets- On Exterior:
 - 1. Install sheets shingle-fashion to shed water, with seams generally horizontal.
 - 2. Overlap seams as recommended by manufacturer but at least 6 inches.
 - 3. Overlap at outside and inside corners as recommended by manufacturer but at least 12 inches.
 - 4. For application specified to be air tight, seal seams, laps, penetrations, tears, and cuts with self-adhesive tape; use only large-headed, gasketed fasteners recommended by the manufacturer.
 - 5. Install head flashings under weather barrier.
 - 6. Install air barrier and vapor retarder UNDER jamb flashings.
 - 7. At openings to be filled with frames having nailing flanges, wrap excess sheet into opening; at head, seal sheet over flange and flashing.
- E. Mechanically Fastened Sheets-Vapor Retarder on Interior:
 - 1. When insulation is to be installed in assembly, install vapor retarder over insulation.
 - 2. Anchor to wood framing using large-headed nails or staples at 12 to 18 inches on center along each framing member covered; cover fasteners with seam tape.
 - 3. Seal seams, laps, perimeter edges, penetrations, tears, and cuts with self-adhesive tape, making air tight seal.

**KOPACHUCK STATE PARK
DAY USE DEVELOPMENT**

F. Openings and Penetrations in Exterior Weather Barriers:

1. Install membrane system in accordance with manufacturer recommendations.
2. Install flashing over sills, covering entire sill frame member, extending at least 5 inches onto weather barrier and at least 6 inches up jambs; mechanically fasten stretched edges.
3. At openings to be filled with frames having nailing flanges, seal head and jamb flanges using a continuous bead of sealant compressed by flange and cover flanges with at least 4 inches wide; do not seal sill flange.
4. At openings to be filled with non-flanged frames, seal weather barrier to all sides of opening framing, using flashing at least 9 inches wide, covering entire depth of framing.
5. At head of openings, install flashing under weather barrier extending at least 2 inches beyond face of jambs; seal weather barrier to flashing.
6. At interior face of openings, seal gap between window/door frame and rough framing, using joint sealant over backer rod.
7. Service and Other Penetrations: Form flashing around penetrating item and seal to weather barrier surface.

G. Installation of Vapor Barriers in Crawl Space:

1. Install vapor retarder over prepared grade. Lap joints a minimum of 12 inches and seal with manufacturer's recommended tape. Install second layer over pathways to equipment.
2. Extend vapor retarder over footings and seal to foundation wall or grade beam with manufacturer's recommended tape. Extend vapor retarder vertically minimum 16 inches above top of foundation wall.
3. Seal around penetrations such as utilities and columns in order to create a monolithic, airtight membrane at grade surface, perimeter, and all vertical penetrations.

END OF SECTION 072500

**KOPACHUCK STATE PARK
DAY USE DEVELOPMENT**

SECTION 074113 – METAL ROOF PANELS

PART 1 – GENERAL

1.1 SECTION INCLUDES

- A. Architectural Metal Roof Panels.

1.2 RELATED REQUIREMENTS

- A. 079200 – Joint Sealers: for joint sealant installed with system.

1.3 SUBMITTALS

- A. Qualification Data: For Installer, design engineer.
- B. Product Data: Provide product criteria, characteristics, accessories, jointing and seaming methods, and termination conditions.
 - 1. Summary of test results, indicating compliance with specified requirements.
 - 2. Specimen warranty.
- C. Shop Drawings: Include layouts of roof panels, details of edge and penetration conditions, spacing and type of connections, flashings, underlayments, and special conditions.
 - 1. Show work to be field-fabricated or field-assembled.
- D. Sample: For each roofing system specified, submit samples of minimum size 12 inches square, representing actual roofing metal, thickness, profile, color, and texture.
- E. Manufacturer's Installation Instructions: Indicate special preparation of substrate, installation and attachment methods, and perimeter conditions requiring special attention.
- F. Warranty: Submit manufacturer warranty and ensure forms have been completed in
- G. Owner's name and registered with manufacturer.
- H. Maintenance Data: For users operation and maintenance of system including:
 - 1. Methods for maintaining system's materials and finishes.
 - 2. Precautions about cleaning materials and methods that could be detrimental to components, finishes, and performance.

1.4 QUALITY ASSURANCE

**KOPACHUCK STATE PARK
DAY USE DEVELOPMENT**

- A. Manufacturer Qualifications: Company specializing in the manufacture of roofing systems similar to those required for this project.
 - 1. Not less than 5 years of documented experience.
- B. Installer Qualifications: Company trained and authorized by roofing system manufacturer and specializing in performing the work of this section with minimum 5 years experience.

1.5 DELIVERY, STORAGE, AND HANDLING

- A. As required by the manufacturer for a warrantable installation of the installed products to meet the Performance and Design Criteria.

1.6 WARRANTY

- A. Finish Warranty: Provide manufacturer's special warranty covering failure of factory-applied exterior finish on metal roof panels and agreeing to repair or replace panels that show evidence of finish degradation, including significant chalking, cracking, or peeling within specified warranty period of 20 year period from date of Substantial Completion.

PART 2 – PRODUCTS

2.1 DESCRIPTION

- A. Complete roofing assemblies, including factory formed panels with factory applied finish roof panels, clips, fasteners, connectors, and miscellaneous accessories, tested for conformance with performance criteria.

2.2 PERFORMANCE AND DESIGN CRITERIA

- A. Design system to accommodate without deformation anticipated thermal movement over ambient temperature range of 100 degrees F.
- B. Structural Performance: Provide metal panel systems capable of withstanding the effects of the following loads, based on testing according to ASTM E 330:
 - 1. Design and size components to withstand dead and live loads caused by positive and negative wind pressure acting normal to plane of wall as calculated in accordance with code.
 - 2. Maximum Allowable Deflection of Panel: 1/180 of span.
- C. Roof Covering External Fire-Resistance Classification: UL Class A.

**KOPACHUCK STATE PARK
DAY USE DEVELOPMENT**

- D. Wind Uplift: Class 90 wind uplift resistance of UL 580.
- E. Provide positive drainage to exterior for moisture entering or condensation occurring within panel system.
- F. Provide continuity of thermal barrier at building enclosure elements and continuity of air barrier and vapor retarder seal at building enclosure elements in conjunction with materials specified in Section 072500 Weather Barriers.
- G. Accommodate movement within system without damage to components or deterioration of seals, movement within system; movement between system and perimeter components when subject to seasonal temperature cycling; dynamic loading and release of loads; and deflection of structural support framing.
- H. Fabricate and finish panels and accessory items at factory, using manufacturer's standard processes as required to achieve specified appearance and performance requirements.
- I. Factory-install captive gaskets, sealants, or separator strips at panel joints to provide weathertight seals, eliminate metal-to-metal contact, and minimize noise from panel movements.

2.3 MATERIALS

- A. Steel Sheet: Zinc-coated (galvanized) steel sheet complying with ASTM A 653, G90 coating designation, or aluminum-zinc alloy-coated steel sheet complying with ASTM A 792, Class AZ50 coating designation; structural quality. Smooth surface texture; continuous-coil-coated on exposed surfaces with specified finish coating and on panel back with specified panel back coating.
 - 1. Features:
 - a. Sheet Thickness: As scheduled below.
 - b. Alloy: Manufacturer's standard, selected for best appearance and finish durability.

2.4 MANUFACTURERS

- A. Specification is based on profiles and standard finishes by AEP Span.
 - 1. Comparable products by one of the following are also acceptable. See Section 016000 - Product Requirements for submittal requirements.
 - a. FABRAL.
 - b. Morin.

**KOPACHUCK STATE PARK
DAY USE DEVELOPMENT**

2. Substitutions for products by manufacturers other than those listed above: See Section 016000 - Product Requirements.

2.5 METAL ROOF PANELS

- A. Low Slope Roof: Basis of Design Product: Span-Lok HP with striations by AEP Span. Comparable and substituted products will be judged based on the following performance criteria, features, warranty, and qualifications.
 1. Features:
 - a. Panel Material: Steel Sheet.
 - b. Sheet Thickness: Nominal 24 gage minimum, as required to meet performance
 - c. criteria.
 - d. Panel Coverage: 16 inches.
 - e. Field Seam: 180 degrees.
 - f. Depth: 2 inch.
 - g. Attachment: Standing seam, color match to panel finish.
 - h. Length: Maximum possible length to minimize lapped joints.
 - i. Profile: Rib striations.
 - j. Color: To be selected from AEP-Span Architectural Color Chart: Dura Tech 5000 Standard Colors.

2.6 ACCESSORIES

- A. All accessory materials required by the manufacturer for a warrantable installation of the installed products in a manner that meets the Performance and Design Criteria.
- B. Miscellaneous Sheet Metal Items: Provide flashings, gutters, downspouts, trim, moldings, ridge cap, closure strips, preformed crickets, and skylight curbs of the same material, thickness, and finish as used for the roofing panels.
- C. Underlayment: Self-adhering rubber-modified asphalt sheet complying with ASTM D1970/D1970M; 22 mil total thickness; with strippable release film and woven polypropylene sheet top surface.
 1. Self Sealability: Passing nail sealability test specified in ASTM D1970/D1970M.
 2. Low Temperature Flexibility: Passing test specified in ASTM D1970/D1970M.
 3. High Temperature: must meet AAMA 711 specification for heat exposure range "Level 3"
 4. Water Vapor Permeance: 0.067 perm, when tested in accordance with ASTM E96/E96M Procedure A (desiccant method).
 5. Functional Temperature Range: Minus 70 degrees F to 212 degrees F.

**KOPACHUCK STATE PARK
DAY USE DEVELOPMENT**

- D. Sealants:
 - 1. Exposed sealant must cure to rubber-like consistency.
 - 2. Concealed sealant must be non-hardening type.
- E. Rib and Ridge Closures: Provide prefabricated, close-fitting components of same material and finish as roof panels.
- F. Attachment:
 - 1. Concealed System: Provide manufacturer's standard stainless steel concealed anchor clips designed for specific roofing system and engineered to meet performance requirements, including anticipated thermal movement.

PART 3 – EXECUTION

3.1 EXAMINATION

- A. Verify existing conditions meet the manufacturer's requirements before starting work.

3.2 PREPARATION

- A. Prepare surfaces to receive work in accordance with manufacturer's instructions.

3.3 INSTALLATION

- A. General: Install all materials in accordance with manufacturer's instructions based on conditions present.
- B. Coordinate with installation of associated counterflashings and other components installed under other sections

3.4 CLEANING

- A. Clean exposed sheet metal work at completion of installation. Remove grease and oil films, excess joint sealer, handling marks, and debris from installation, leaving the work clean and unmarked, free from dents, creases, waves, scratch marks, or other damage to the finish.

3.5 PROTECTION

- A. Protect installed work as required by the manufacturer to maintain product performance, design criteria and warranty.

END OF SECTION 074113

**KOPACHUCK STATE PARK
DAY USE DEVELOPMENT**

SECTION 074646 - FIBER-CEMENT SIDING

PART 1 - GENERAL

1.1 SUMMARY

- A. Section includes fiber-cement exterior siding including trim and batten boards.

1.2 ACTION SUBMITTALS

- A. Product Data: For each type of product.
- B. Samples: For fiber-cement siding including related accessories.

1.3 INFORMATIONAL SUBMITTALS

- A. Product certificates.
- B. Product test reports.
- C. Research/evaluation reports.
- D. Sample warranty.

1.4 CLOSEOUT SUBMITTALS

- A. Maintenance data.

1.5 WARRANTY

- A. Product Warranty:
 - 1. Hardie Panel HZ10 vertical siding for 30 years; transferable.
 - 2. HardieTrim HZ10 boards for 15 years; transferable.

PART 2 - PRODUCTS

2.1 FIBER-CEMENT SIDING

- A. General: ASTM C1186, Type A, Grade II, fiber-cement board, noncombustible when tested according to ASTM E136; with a flame-spread index of 25 or less when tested according to ASTM E84.

**KOPACHUCK STATE PARK
DAY USE DEVELOPMENT**

1. James Hardie Building Products, Inc. or approved equal.

- B. Labeling: Provide fiber-cement siding that is tested and labeled according to ASTM C1186 by a qualified testing agency acceptable to authorities having jurisdiction.

- C. Nominal Thickness: Not less than 5/16 inch.

- D. Vertical Pattern: Cedarmill Vertical siding panel
 1. 4 feet by 8 feet
 2. 4 feet by 9 feet
 3. 4 feet by 10 feet

- E. Panel Texture: Wood-grain texture.

- F. Factory Priming: Provide factory applied universal primer by James Hardie.

2.2 ACCESSORIES

- A. Siding Accessories, General: Provide starter strips, edge trim, outside and inside corner caps, and other items as recommended by siding manufacturer for building configuration. Provide 5/4 HardieTrim board and HardieTrim Batten Boards; Primed Rustic Grain finish. See drawings for required widths.

- B. Flashing: Provide aluminum flashing complying with Section 076200 "Sheet Metal Flashing and Trim" at window and door heads and where indicated by Construction Drawings and manufacturer specifications.
 1. Finish for Aluminum Flashing: Siliconized polyester coating.

- C. Fasteners:
 1. For fastening fiber cement, use stainless steel fasteners.

PART 3 - EXECUTION

3.1 INSTALLATION

- A. General: Comply with manufacturer's written installation instructions applicable to products and applications indicated unless more stringent requirements apply.
 1. Install fasteners no more than 16 inches on center.
 2. Block framing between studs where HardiePanel siding horizontal joints occur.
 3. Place fasteners no closer than 3/8 inch from panel edges and 2 inches from panel corners.
 4. Maintain clearance between siding and adjacent finished grades.

**KOPACHUCK STATE PARK
DAY USE DEVELOPMENT**

- B. Install joint sealants as specified in Section 079200 "Joint Sealers" and to produce a weathertight installation.
- C. Verify weather barrier has been installed over substrate completely and correctly.
- D. Install aluminum flashing above door, window trim and casings and where indicated. Install flashing at horizontal joints per manufacturer's recommendations.
- E. Finish unprimed siding and with a minimum one coat high quality, alkali resistant primer.

3.2 ADJUSTING AND CLEANING

- B. Remove damaged, improperly installed, or otherwise defective materials and replace with new materials complying with specified requirements.
- C. Clean finished surfaces according to manufacturer's written instructions and maintain in a clean condition during construction.

END OF SECTION 074646

**KOPACHUCK STATE PARK
DAY USE DEVELOPMENT**

SECTION 076200 – SHEET METAL FLASHING AND TRIM

PART 1 – GENERAL

1.1 SECTION INCLUDES

- A. Fabricated sheet metal items.

1.2 RELATED REQUIREMENTS

- A. 072500 - Weather Barriers: moisture protection and underlayments under sheet metal flashings
- B. 079200 - Joint Sealers.

1.3 SUBMITTALS

- A. Qualification Data: Company specializing in performing the work of this section with minimum 5 years experience on projects of similar size and complexity.
- B. Shop Drawings: Indicate material profile, jointing locations, jointing details, fastening methods, flashings, terminations, and installation details.
- C. Samples:
 - 1. Finish Sample: Submit two samples illustrating each metal finish color.
- D. Warranty: Submit manufacturer finish warranty and ensure forms have been completed in Owner's name and registered with manufacturer.

1.4 QUALITY ASSURANCE

- A. Fabricators Qualifications: Company specializing in performing the work of this section with minimum 5 years experience on projects of similar size and complexity.

1.5 DELIVERY, STORAGE, AND HANDLING

- A. As required by the manufacturer for a warrantable installation of the installed products to meet the Performance and Design Criteria.

**KOPACHUCK STATE PARK
DAY USE DEVELOPMENT**

1.6 WARRANTY

- A. Manufacturer's Finish Warranty: Correct defective work within a 20 year period after Substantial Completion for degradation of panel finish, including color fading caused by exposure to weather.
 - 1. Panel Finish Criteria are listed AAMA 2605.

PART 2 – PRODUCTS

2.1 DESCRIPTION

- A. Sheet metal including steel, stainless steel, and aluminum fabricated into items such as flashings, counterflashings, gutters, downspouts, and other items indicated and scheduled.

2.2 MATERIALS

- A. Pre-Finished Galvanized Steel: ASTM A653/A653M, with G90/Z275 zinc coating; minimum 0.02 inch thick base metal, shop pre-coated with PVDF coating.
 - 1. Fluoropolymer Coating: Superior Performance Organic Finish, AAMA 2605; multiple coat, thermally cured fluoropolymer finish system.
 - 2. Color: As scheduled below and indicated on drawings.
- B. Pre-Finished Aluminum: ASTM B209 (ASTM B209M) 0.032 inch thick; plain Finish shop pre-coated with fluoropolymer coating.
 - 1. Fluoropolymer Coating: Superior Performance Organic Finish, AAMA 2605; multiple coat, thermally cured fluoropolymer finish system.
 - 2. Color: To be selected from manufacturer's color selection.

2.3 FABRICATION

- A. Form sections true to shape, accurate in size, square, and free from distortion or defects.
- B. Form pieces in longest possible lengths.
- C. Fabricate corners from one piece with minimum 18 inch long legs; seam for rigidity, seal with sealant.
- D. Fabricate vertical faces with bottom edge formed outward 1/4 inch and hemmed to form drip.

2.4 ACCESSORIES

- A. All accessory materials required by the manufacturer for a warrantable installation of the

**KOPACHUCK STATE PARK
DAY USE DEVELOPMENT**

installed products in a manner that meets the Performance and Design Criteria.

- B. Flexible Flashing:
 - 1. For use under metal copings and flashings Section 072500 - Weather Barriers; use high temperature type.
- C. Slip Sheet: Rosin sized building paper.
- D. Protective Backing Paint: See Section 099113 – Exterior Painting.
- E. Sealant: As specified in Section 079200 - Joint Sealers.
- F. Gutters and Downspouts: One piece leaf covered seamless gutter system.

PART 3 – EXECUTION

3.1 EXAMINATION

- A. Verify existing conditions meet the manufacturer's requirements before starting work.

3.2 PREPARATION

- A. Prepare surfaces to receive work in accordance with manufacturer's instructions.

3.3 INSTALLATION

- A. General: Install all materials in accordance with manufacturer's instructions based on conditions present.

3.4 ADJUSTING

- A. Adjust and lubricate hardware for proper operation.

3.5 PROTECTION

- A. Protect installed work as required by the manufacturer to maintain product performance,

**KOPACHUCK STATE PARK
DAY USE DEVELOPMENT**

design criteria and warranty.

END OF SECTION 076200

**KOPACHUCK STATE PARK
DAY USE DEVELOPMENT**

SECTION 079200 - JOINT SEALERS

PART 1 - GENERAL

1.1 SECTION INCLUDES

- A. Nonsag gunnable joint sealants.
- B. Joint backings and accessories.

1.2 RELATED REQUIREMENTS

- A. Section 072500 - Weather Barriers: Sealants required in conjunction with air barriers and vapor retarders.
- B. Section 074646 - Fiber Cement Siding: Joint sealants.
- C. Section 084313 - Aluminum-Framed Storefronts: Joint sealants.
- D. Section 087100 - Door Hardware: Setting exterior door thresholds in sealant.
- E. Section 088000 - Glazing: Glazing sealants and accessories.
- F. Section 092116 - Gypsum Board Assemblies: Sealing acoustical and sound-rated walls and ceilings.
- G. Section 093013 – Ceramic Tiling: Sealant between tile and plumbing fixtures and at junctions with other materials and changes in plane.

1.3 REFERENCE STANDARDS

- A. ASTM C661 - Standard Test Method for Indentation Hardness of Elastomeric-Type Sealants by Means of a Durometer; 2006 (Reapproved 2011).
- B. ASTM C834 - Standard Specification for Latex Sealants; 2014.
- C. ASTM C919 - Standard Practice for Use of Sealants in Acoustical Applications; 2012.
- D. ASTM C920 - Standard Specification for Elastomeric Joint Sealants; 2014.
- E. ASTM C1193 - Standard Guide for Use of Joint Sealants; 2013.
- F. ASTM C1248 - Standard Test Method for Staining of Porous Substrate by Joint Sealants; 2008 (Reapproved 2012).
- G. ASTM C1521 - Standard Practice for Evaluating Adhesion of Installed Weatherproofing

**KOPACHUCK STATE PARK
DAY USE DEVELOPMENT**

H. Sealant Joints; 2013.

1.4 SUBMITTALS

- A. See Section 013000 – Submittal Procedures, for submittal procedures.
- B. Product Data for Sealants: Submit manufacturer's technical data sheets for each product to be used, that includes the following.
 - 1. Physical characteristics, including movement capability, VOC content, hardness, cure time, and color availability.
 - 2. List of backing materials approved for use with the specific product.
 - 3. Substrates that product is known to satisfactorily adhere to and with which it is compatible.
 - 4. Substrates the product should not be used on.
 - 5. Installation instructions, including precautions, limitations, and recommended backing materials and tools.
- C. Product Data for Accessory Products: Submit manufacturer's technical data sheet for each product to be used, including physical characteristics, installation instructions, and recommended tools.
- D. Color Cards for Selection: Where sealant color is not specified, submit manufacturer's color cards showing standard colors available for selection.
- E. Installation Plan: Submit at least four weeks prior to start of installation.
- F. Preinstallation Field Adhesion Test Plan: Submit at least two weeks prior to start of installation.
- G. Preinstallation Field Adhesion Test Reports: Submit filled out Preinstallation Field
- H. Adhesion Test Reports log within 10 days after completion of tests; include bagged test samples and photographic records.

1.5 QUALITY ASSURANCE

- A. Installation Plan: Include schedule of sealed joints, including the following.
 - 1. Joint width indicated in contract documents.
 - 2. Joint depth indicated in contract documents; to face of backing material at centerline of joint.
 - 3. Method to be used to protect adjacent surfaces from sealant droppings and smears,
 - 4. with acknowledgement that some surfaces cannot be cleaned to like-new condition and therefore prevention is imperative.

**KOPACHUCK STATE PARK
DAY USE DEVELOPMENT**

- B. Preinstallation Field Adhesion Test Plan: Include destructive field adhesion testing of one sample of each combination of sealant type and substrate, except interior acrylic latex sealants, and include the following for each tested sample.
1. Identification of testing agency.
 2. Preinstallation Field Adhesion Test Log Form: Include the following data fields, with known information filled out.
 - a. Test date.
 - b. Copy of test method documents.
 - c. Age of sealant upon date of testing.
 - d. Test results, modeled after the sample form in the test method document.
 - e. Indicate use of photographic record of test.
- C. Field Adhesion Test Procedures:
1. Allow sealants to fully cure as recommended by manufacturer before testing.
 2. have a copy of the test method document available during tests.
 3. Record the type of failure that occurred, other information required by test method, and the information required on the Field Quality Control Log.
 4. When performing destructive tests, also inspect the opened joint for proper installation characteristics recommended by manufacturer, and report any deficiencies.
 5. Deliver the samples removed during destructive tests in separate sealed plastic bags, identified with project, location, test date, and test results, to Owner.
 6. If any combination of sealant type and substrate does not show evidence of
 7. minimum adhesion or shows cohesion failure before minimum adhesion, report
 8. results to Architect.
- D. Destructive Field Adhesion Test: Test for adhesion in accordance with ASTM C1521, using Destructive Tail Procedure.
1. Sample: At least 18 inch long.
 2. Minimum Elongation Without Adhesive Failure: Consider the tail at rest, not under any elongation stress; multiply the stated movement capability of the sealant in percent by two; then multiply 1 inch by that percentage; if adhesion failure occurs before the "1 inch mark" is that distance from the substrate, the test has failed.
 3. If either adhesive or cohesive failure occurs prior to minimum elongation, take necessary measures to correct conditions and re-test; record each modification to products or installation procedures.

1.6 WARRANTY

- A. See Section 017700 - Closeout Procedures, for additional warranty requirements.
- B. Correct defective work within a five year period after Date of Substantial Completion.
- C. Warranty: Include coverage for installed sealants and accessories that fail to achieve
- D. watertight seal, exhibit loss of adhesion or cohesion, or do not cure.

**KOPACHUCK STATE PARK
DAY USE DEVELOPMENT**

PART 2 - PRODUCTS

2.1 JOINT SEALANT APPLICATIONS

A. Scope:

1. Exterior Joints: Seal open joints, whether or not the joint is indicated on the drawings, unless specifically indicated not to be sealed. Exterior joints to be sealed include, but are not limited to, the following items.
 - a. Wall expansion and control joints.
 - b. Joints between door, window, and other frames and adjacent construction.
 - c. Joints between different exposed materials.
 - d. Other joints indicated below.
2. Interior Joints: Do not seal interior joints unless specifically indicated to be sealed.
3. Interior joints to be sealed include, but are not limited to, the following items.
 - a. Joints between door, window, and other frames and adjacent construction.
 - b. In sound-rated wall and ceiling assemblies, gaps at electrical outlets, wiring devices, piping, and other openings; between wall/ceiling and other construction; and other flanking sound paths.
 - c. Other joints indicated below.
4. Interior Wet Areas: Bathrooms, restrooms, kitchens, and food service areas; fixtures in wet areas include plumbing fixtures, food service equipment, countertops, cabinets, and other similar items.
5. Sound-Rated Assemblies: Walls and ceilings identified as "STC-rated", "sound-rated, or "acoustical".
6. Do not seal the following types of joints.
 - a. Joints indicated to be treated with manufactured expansion joint cover or some other type of sealing device.
 - b. Joints where sealant is specified to be provided by manufacturer of product to be sealed.
 - c. Joints where installation of sealant is specified in another section.
 - d. Joints between suspended panel ceilings/grid and walls.

B. Exterior Joints: Use non-sag non-staining silicone sealant, unless otherwise indicated.

1. Lap Joints in Sheet Metal Fabrications: Polyurethane Sealant.

C. Interior Joints: Use nonsag Mildew-resistant silicone sealant, unless otherwise indicated.

1. Wall and Ceiling Joints in Non-Wet Areas: Acrylic emulsion latex sealant.
2. Joints between Fixtures in Wet Areas and Floors, Walls, and Ceilings: Mildew-resistant silicone sealant; white.
3. In Sound-Rated Assemblies: Acrylic emulsion latex sealant.

**KOPACHUCK STATE PARK
DAY USE DEVELOPMENT**

2.2 JOINT SEALANTS – GENERAL

- A. Sealants and Primers: Provide products with low levels of volatile organic compound (VOC) content.

2.3 NONSAG JOINT SEALANTS

- A. Non-Staining Silicone Sealant: ASTM C920, Grade NS, Uses M and A; not expected to withstand continuous water immersion or traffic.

1. Movement Capability: Plus and minus 50 percent, minimum.
2. Non-Staining To Porous Stone: Non-staining to light-colored natural stone when tested in accordance with ASTM C1248.
3. Dirt Pick-Up: Reduced dirt pick-up compared to other silicone sealants.
4. Color: To be selected by Architect from manufacturer's standard range.
5. Cure Type: Single-component, neutral moisture curing.
6. Manufacturers:
 - a. Dow Corning Corporation; 790 Silicone Building Sealant: www.dowcorning.com/construction/sle.
 - b. Substitutions: See Section 016000 - Product Requirements.

- B. Mildew-Resistant Silicone Sealant: ASTM C920, Grade NS, Uses M and A; single component, mildew resistant; not expected to withstand continuous water immersion or traffic.

1. Color: White.
2. Manufacturers:
 - a. Pecora Corporation; 898NST Sanitary Silicone Sealant - Class 50: www.pecora.com.
 - b. Sika Corporation; Sikasil GP: www.usa-sika.com.
 - c. Substitutions: See Section 016000 - Product Requirements.

- C. Polyurethane Sealant: ASTM C920, Grade NS, Uses M and A; single or multi-component; not expected to withstand continuous water immersion or traffic.

1. Movement Capability: Plus and minus 25 percent, minimum.
2. Hardness Range: 20 to 35, Shore A, when tested in accordance with ASTM C661.
3. Color: To be selected by Architect from manufacturer's standard range.
4. Manufacturers:
 - a. Pecora Corporation; DynaTrol I-XL General Purpose One Part Polyurethane Sealant: www.pecora.com.
 - b. The QUIKRETE Companies; QUIKRETE® Polyurethane Non-Sag Sealant: www.quikrete.com.
 - c. Substitutions: See Section 016000 - Product Requirements.

**KOPACHUCK STATE PARK
DAY USE DEVELOPMENT**

- D. Acrylic Emulsion Latex: Water-based; ASTM C834, single component, non-staining, non-bleeding, non-sagging; not intended for exterior use.
 - 1. Color: To be selected by Architect from manufacturer's standard range.
 - 2. Grade: ASTM C834; Grade - Minus 18 Degrees C.

2.4 ACCESSORIES

- A. Backer Rod: Cylindrical cellular foam rod with surface that sealant will not adhere to, compatible with specific sealant used, and recommended by backing and sealant manufacturers for specific application.
- B. Backing Tape: Self-adhesive polyethylene tape with surface that sealant will not adhere to and recommended by tape and sealant manufacturers for specific application.
- C. Masking Tape: Self-adhesive, nonabsorbent, non-staining, removable without adhesive residue, and compatible with surfaces adjacent to joints and sealants.
- D. Joint Cleaner: Non-corrosive and non-staining type, type recommended by sealant manufacturer; compatible with joint forming materials.

PART 3 - EXECUTION

3.1 EXAMINATION

- A. Verify that joints are ready to receive work.
- B. Verify that backing materials are compatible with sealants.
- C. Verify that backer rods are of the correct size.
- D. Preinstallation Adhesion Testing: Install a sample for each test location shown in the test plan.
 - 1. Test each sample as specified in PART 1 under QUALITY ASSURANCE article.
 - 2. Notify Architect of date and time that tests will be performed, at least 7 days in advance.
 - 3. Record each test on Preinstallation Adhesion Test Log as indicated.
 - 4. If any sample fails, review products and installation procedures, consult manufacturer, or take whatever other measures are necessary to ensure adhesion; re-test in a different location; if unable to obtain satisfactory adhesion, report to Architect.
 - 5. After completion of tests, remove remaining sample material and prepare joint for new sealant installation.

3.2 PREPARATION

- A. Remove loose materials and foreign matter that could impair adhesion of sealant.
- B. Clean joints, and prime as necessary, in accordance with manufacturer's instructions.

**KOPACHUCK STATE PARK
DAY USE DEVELOPMENT**

- C. Perform preparation in accordance with manufacturer's instructions and ASTM C1193.
- D. Mask elements and surfaces adjacent to joints from damage and disfigurement due to sealant work; be aware that sealant drips and smears may not be completely removable.

3.3 INSTALLATION

- A. Perform work in accordance with sealant manufacturer's requirements for preparation of surfaces and material installation instructions.
- B. Perform installation in accordance with ASTM C1193.
- C. Perform acoustical sealant application work in accordance with ASTM C919.
- D. Install bond breaker backing tape where backer rod cannot be used.
- E. Install sealant free of air pockets, foreign embedded matter, ridges, and sags, and without getting sealant on adjacent surfaces.
- F. Do not install sealant when ambient temperature is outside manufacturer's recommended temperature range, or will be outside that range during the entire curing period, unless manufacturer's approval is obtained and instructions are followed.
- G. Nonsag Sealants: Tool surface concave, unless otherwise indicated; remove masking tape immediately after tooling sealant surface.

END OF SECTION 079200

**KOPACHUCK STATE PARK
DAY USE DEVELOPMENT**

SECTION 081113 – HOLLOW METAL DOORS AND FRAMES

PART 1 - GENERAL

1.1 SECTION INCLUDES

- A. Non fire rated steel doors.
- B. Non fire rated steel frames.
- C. Exterior steel frames.
- D. Vision lite frames.

1.2 RELATED REQUIREMENTS

- A. 087100 - Door Hardware: For hardware installed in hollow metal doors
- B. 099113 – Exterior Painting and Section 099123 Interior Painting
- C. 088000- Glazing

1.3 SUBMITTALS

- A. Product Data: Materials and details of design and construction, hardware locations, reinforcement type and locations, anchorage and fastening methods, and finishes. Include U-value data for thermally broken doors and frames.
- B. Shop Drawings: Details of each opening, showing elevations, glazing, frame profiles, and identifying location of different finishes, if any.
- C. Manufacturer's Installation Instructions: Indicate special preparation of substrate, installation and attachment methods, and perimeter conditions requiring special attention.
- D. Warranty: Submit manufacturer warranty and ensure forms have been completed in Owner's name and registered with manufacturer.
- E. Maintenance Data: For users operation and maintenance of system including:
 - 1. Methods for maintaining system's materials and finishes.
 - 2. Precautions about cleaning materials and methods that could be detrimental to components, finishes, and performance.

1.4 QUALITY ASSURANCE

- A. Manufacturer Qualifications: Company specializing in manufacturing the products specified in this section with minimum five years documented experience.

1.5 DELIVERY, STORAGE, AND HANDLING

- A. As required by the manufacturer for a warrantable installation of the installed products to meet the Performance and Design Criteria.

**KOPACHUCK STATE PARK
DAY USE DEVELOPMENT**

PART 2 - PRODUCTS

2.1 DESCRIPTION

- A. Hollow metal frames for hollow metal doors, wood doors and glazing. Hollow metal doors for non-fire rated and insulated openings.

2.2 PERFORMANCE AND DESIGN CRITERIA

- A. Comply with ANSI/ICC A117.1. Accessibility Code.
- B. Comply with ANSI A250.8 in general and for grade and style specified.
- C. NAAMM HMMA doors of equivalent or better construction are allowed.
- D. Provide hardware preparation in accordance with BHMA A156.115, with reinforcement welded in place, in addition to other requirements specified in door grade standard. Coordinate with Section 087100 - Door Hardware.

2.3 MATERIALS

- A. Non-fire-rated steel doors.
 - 1. Basis of Design Product: Ceco, Curries or comparable manufacturer. Comparable and substituted products will be judged based on the following performance criteria, features, warranty, and qualifications.
 - 2. Performance Criteria:
 - a. Grade: ANSI A250.8 Level 3 (Extra Heavy Duty), physical performance Level A, Model 1, Full Flush, 16 gage.
 - b. Thickness: 1-3/4 inches.
 - c. Exterior Doors, Non-Fire-Rated, Thermally Insulated:
 - 1) Galvanizing: All components hot-dipped zinc-iron alloy-coated (galvannealed) in accordance with ASTM A653/A653M, with manufacturer's standard coating thickness.
 - 2) Insulating Value: U-value of 0.37, when tested in accordance with ASTM C1363.
 - 3) Basis of Design: Treo-E Door by CecoDoor/Assa Abloy.
 - 3. Features:
 - a. Door Top and Closures: Steel, Flush with top of faces and edges.
 - b. Door Edge Profile: Beveled on both edges.
 - c. Face Texture: Smooth.
 - d. Finish: Factory primed for field finishing.
 - e. Field Finish: In accordance with Section 099000 – Exterior Painting or Section 099123 – Interior Painting as appropriate

**KOPACHUCK STATE PARK
DAY USE DEVELOPMENT**

- f. Field Finish Color: To be selected from manufacturer's full range.
 - B. Non-Fire Rated Door Frames:
 - 1. Performance Criteria:
 - a. Comply with the requirements of grade specified for corresponding door.
 - b. Frame Finish: Factory primed and field finished.
 - C. Exterior Door Frames: Face welded type.
 - 1. Galvanizing:
 - a. Galvanizing: All components hot-dipped zinc-iron alloy-coated (galvannealed) in accordance with ASTM A653/A653M, with manufacturer's standard coating thickness; 16 gage.
 - b. Provide with true thermal break.
 - D. Interior Door Frames:
 - 1. Non-Fire Rated, full profile/continuously welded type, 16 gage
- 2.4 ACCESSORIES
- A. All accessory materials required by the manufacturer for a warrantable installation of the installed products in a manner that meets the Performance and Design Criteria.
 - B. Glazing: As specified in Section 088000 - Glazing
 - C. Mineral Fiber Insulation: for filling frame cavities.
- 2.5 FINISHING
- A. Primer: Rust-inhibiting, complying with ANSI A250.10, door manufacturer's standard.
 - B. Field Finish: In accordance with Section 099113 – Exterior Painting or Section 099123 – Interior Painting as appropriate.

PART 3 - EXECUTION

3.1 EXAMINATION

- A. Verify existing conditions meet the manufacturer's requirements before starting work.

3.2 PREPARATION

- A. Prepare surfaces to receive work in accordance with manufacturer's instructions.
- B. Coat inside of frames with bituminous coating to a thickness of 1/16 inch.

**KOPACHUCK STATE PARK
DAY USE DEVELOPMENT**

3.3 INSTALLATION

- A. General: Install all materials in accordance with manufacturer's instructions based on conditions present.
- B. Install in accordance with the requirements of the specified door grade standard and NAAMM HMMA 840.
- C. Seal seam at top closures after finish is applied to create a smooth surface with out groove or pits
 - 1. Seal with sealant Per Section 079200- Joint Sealers.
- D. Pack all frames with insulation.
- E. Coordinate installation of hardware.
- F. Coordinate installation of electrical connections to electrical hardware items.
- G. Touch up damaged factory finishes.

3.4 TOLERANCES

- A. Clearances Between Door and Frame: As specified in ANSI A250.8.
- B. Maximum Diagonal Distortion: 1/16 in measured with straight edge, corner to corner.

3.5 ADJUSTING

- A. Adjust and lubricate hardware for proper operation.
- B. Adjust for smooth and balanced door movement in accordance with manufacturer's instructions.

3.6 PROTECTION

- A. Protect installed work as required by the manufacturer to maintain product performance, design criteria and warranty.

3.7 SCHEDULE

- A. Refer to door schedule on drawings.

END OF SECTION 081113

**KOPACHUCK STATE PARK
DAY USE DEVELOPMENT**

SECTION 081416 – FLUSH WOOD DOORS

PART 1 - GENERAL

1.1 SECTION INCLUDES

- A. Non fire rated wood doors.

1.2 RELATED REQUIREMENTS

- A. 087100 - Door Hardware: for hardware installed in wood doors
- B. 081113 - Hollow Metal Doors and Frames.

1.3 SUBMITTALS

- A. Qualification Data: For Installer and manufacturer.
- B. Product Data: Materials and details of design and construction, hardware locations, reinforcement type and locations, anchorage and fastening methods, and finishes.
- C. Shop Drawings: Details of each opening, showing elevations, glazing, frame profiles.
- D. Sample: Submit two samples face material, manufacturer's standard size showing factory finishes, colors, and surface texture.
- E. Manufacturer's Installation Instructions: Indicate special preparation of substrate, installation and attachment methods, and perimeter conditions requiring special attention.
- F. Warranty: Submit manufacturer warranty and ensure forms have been completed in Owner's name and registered with manufacturer.
- G. Maintenance Data: For users operation and maintenance of system including:
 - 1. Methods for maintaining system's materials and finishes.
 - 2. Precautions about cleaning materials and methods that could be detrimental to components, finishes, and performance.

1.4 QUALITY ASSURANCE

- A. Manufacturer Qualifications: Company specializing in manufacturing the products specified in this section with minimum three years of documented experience.
 - 1. Company with at least one project in the past 5 years with value of woodwork within 20 percent of cost of woodwork for this Project.

**KOPACHUCK STATE PARK
DAY USE DEVELOPMENT**

1.5 DELIVERY, STORAGE, AND HANDLING

- A. As required by the manufacturer for a warrantable installation of the installed products to meet the Performance and Design Criteria.

1.6 WARRANTY

- A. Interior Doors: Provide manufacturer's warranty for the life of the installation.
 - 1. Include coverage for delamination of veneer, warping beyond specified installation tolerances, defective materials, and telegraphing core construction.

PART 2 - PRODUCTS

2.1 MANUFACTURERS

- A. Specification is based LD2000 GreenDoor by Lynden Door.
 - 1. Comparable products by one of the following are also acceptable. See Section 016000 - Product Requirements.
 - 2. ReCor Door.
 - 3. Substitutions for products by manufacturers other than those listed above: See Section 016000 - Product Requirements

2.2 DESCRIPTION

- A. Wood doors for non-fire rated openings.

2.3 PERFORMANCE AND DESIGN CRITERIA

- A. Comply with ANSI/ICC A117.1. Accessibility Code.
- B. Quality Level: Custom Grade, Extra Heavy Duty performance, in accordance with WDMA I.S.1-A for all doors with the following exceptions.
- C. Construction: Flush.
- D. Vertical Edges: Same species as face veneer.
- E. Edge type (AWI "E" type) edge set in between door face veneers.
- F. Door Edge Profile: Beveled on both edges.
- G. Factory machine doors for hardware other than surface-mounted hardware, in accordance with hardware requirements and dimensions.

**KOPACHUCK STATE PARK
DAY USE DEVELOPMENT**

- H. Factory fit doors for frame opening dimensions identified on shop drawings, with edge clearances in accordance with specified quality standard.
- I. Source Limitations: For doors and frames, obtain products from single source from single manufacturer.
- J. Provide hardware preparation in accordance with BHMA A156.115, with reinforcement welded in place, in addition to other requirements specified in door grade standard. Coordinate with Section 087100 - Door Hardware.

2.4 MATERIALS

A. Wood Veneer Facing:

- 1. Wood Veneer Facing for Transparent Finish: Douglas Fir, plain sliced, book matched, veneer grade as specified by quality standard.

B. Cores:

- 1. Cores Constructed with stiles and rails:
 - a. Provide solid blocks for hardware reinforcement.
 - b. Provide solid blocking for other through bolted hardware.
- 2. Non-Rated Solid Core: Type No Added Urea Formaldehyde particleboard core (PC), plies and faces as indicated above.

C. Glazing:

- 1. Types in accordance with Section 088000 - Glazing.

D. Non-fire-rated wood doors.

1. Features:

- a. Thickness: 1-3/4 inches.
- b. Core: Solid.
- c. Facing Material:
 - 1) Wood veneer facing with factory transparent finish.
- d. Color/Finish: To be selected from manufacturer's full range.

2.5 ACCESSORIES

- A. All accessory materials required by the manufacturer for a warrantable installation of the installed products in a manner that meets the Performance and Design Criteria.

**KOPACHUCK STATE PARK
DAY USE DEVELOPMENT**

2.6 FINISHING

- A. Factory Finish: Finish work in accordance with AWI/AWMAC/WI Architectural Woodwork Standards, Section 5 - Finishing for Grade specified and as follows:
 - 1. Transparent:
 - a. System - 11, Polyurethane, Catalyzed.
 - b. Stain: To match sample.
 - c. Sheen: Semigloss.

PART 3 - EXECUTION

3.1 EXAMINATION

- A. Verify existing conditions meet the manufacturer's requirements before starting work.

3.2 INSTALLATION

- A. General: Install all materials in accordance with manufacturer's instructions based on conditions present.
- B. Field-Finished Doors: Trimming to fit is acceptable.
 - 1. Adjust width of non-rated doors by cutting equally on both jamb edges.
 - 2. Trim maximum of 3/4 inch off bottom edges.
- C. Coordinate installation of hardware.
- D. Touch up damaged finishes.

3.3 TOLERANCES

- A. Conform to specified quality standard for fit and clearance tolerances.
- B. Conform to specified quality standard for telegraphing, warp, and squareness.

3.4 ADJUSTING

- A. Adjust and lubricate hardware for proper operation.
- B. Adjust for smooth and balanced door movement in accordance with manufacturer's instructions.

**KOPACHUCK STATE PARK
DAY USE DEVELOPMENT**

3.5 PROTECTION

- A. Protect installed work as required by the manufacturer to maintain product performance, design criteria and warranty.

3.6 SCHEDULE

- A. Refer to door schedule on drawings.

END OF SECTION 081416

**KOPACHUCK STATE PARK
DAY USE DEVELOPMENT**

SECTION 083113 - ACCESS DOORS AND FRAMES

PART 1 - GENERAL

1.1 SUMMARY

- A. Section includes access doors and frames for walls and ceilings.

1.2 ACTION SUBMITTALS

- A. Product Data: For each type of product.
- B. Samples: For each type of access door and frame and for each finish specified.

PART 2 - PRODUCTS

2.1 ACCESS DOORS AND FRAMES

- A. Wall access doors and panels.
 - 1. Recessed Non-Fire Rated Door and Frame Units
 - a. Basis of Design Product:
 - 1) In Gypsum Board on Wood Studs
 - a) Model RW-Series manufactured by Nystrom, Inc.
 - b) Model RDW manufactured by Karp Associates.
 - b. Features:
 - 1) Frame: Drywall bead.
 - 2) Hinges: Concealed.
 - 3) Handle: No handle.
 - 4) Latch/Lock: Screw driver slot for quarter turn cam latch.
 - 5) Gasketing: Manufacturers' standard.
 - 6) Material: Galvanized Steel.
 - 7) Finish: Primed painted for field finish.
 - 8) Size(s): As indicated.

**KOPACHUCK STATE PARK
DAY USE DEVELOPMENT**

- B. Ceiling access doors and panels with concealed flanges.
 - 1. Recessed Non-Fire Rated Door and Frame Units
 - a. Basis of Design Product:
 - 1) In Gypsum Board on Wood Framing:
 - a) Model RW-Series manufactured by Nystrom, Inc.
 - b) Model RDW manufactured by Karp Associates.
 - b. Features:
 - 1) Hinges: Concealed.
 - 2) Handle: No handle.
 - 3) Latch/Lock: Screw driver slot for quarter turn cam latch.
 - 4) Gasketing: Manufacturer's standard.
 - 5) Material: galvanized Steel.
 - 6) Finish: Primed painted for field finish.
 - 7) Size(s): As indicated.

PART 3 - EXECUTION

3.1 INSTALLATION

- A. Comply with manufacturer's written instructions for installing access doors and frames.
- B. Adjust doors and hardware, after installation, for proper operation.

END OF SECTION 083113

**KOPACHUCK STATE PARK
DAY USE DEVELOPMENT**

SECTION 083313 - COILING COUNTER DOORS

PART 1 - GENERAL

1.1 SUMMARY

A. Section Includes:

1. Non- rated coiling counter door and operating hardware.

1.2 ACTION SUBMITTALS

- A. Product Data: For type and size of coiling counter door and accessory.
- B. Shop Drawings: Indicate rough and actual opening dimensions, anchorages methods, hardware locations, and installation details.
- C. Manufacturer's Instructions: Indicate installation sequence and installation, adjustment, and alignment procedures.
- D. Operation and Maintenance Data: Indicate modes of operation, lubrication requirements and frequency, and periodic adjustments required.

1.3 QUALITY ASSURANCE

- A. Installer Qualifications: An entity that employs installers and supervisors who are trained and approved by manufacturer for both installation and maintenance of units required for this Project.

PART 2 - PRODUCTS

2.1 COILING COUNTER DOOR

- A. Coiling Counter Door, Non-Fire Rated, Aluminum slat curtain.
 1. Mounting: Between jambs, within prepared opening.
 2. Nominal Slat Size: 1-1/4 inches wide.
 3. Slat Profile: Flat profile.
 4. Finish: Anodized.
 5. Guides: Formed track; same material and finish.
 6. Hood Enclosure: Match curtain material and finish.
 7. Manual hand chain lift operation.
 8. Locking Device: Equip door with slide bolt and chain lock keeper.
 9. Bottom Bar: Manufacturer's standard continuous channel or tubular shape, fabricated aluminum extrusion and finish to match door..

**KOPACHUCK STATE PARK
DAY USE DEVELOPMENT**

10. Roller Shaft Counterbalance: Steel pipe and torsion steel spring system, capable of producing torque sufficient to ensure smooth operation of curtain from any position and capable of holding position at mid-travel; with adjustable spring tension; requiring 25 lb. nominal force to operate.

PART 3 - EXECUTION

3.1 INSTALLATION, GENERAL

- A. Install coiling counter door and operating equipment complete with necessary hardware, anchors, inserts, hangers, and equipment supports; according to manufacturer's written instructions and as specified.

3.2 CLEANING

- A. Clean installed components.
- B. Remove labels and visible markings.

END OF SECTION 083313

**KOPACHUCK STATE PARK
DAY USE DEVELOPMENT**

SECTION 083513 – ACCORDIAN FOLDING DOORS

PART 1 - GENERAL

1.1 SUMMARY

A. Section Includes:

1. Accordion folding doors, paired openings.
2. Track and operating hardware.

1.2 ACTION SUBMITTALS

- A. Product Data: For each type of product.
- B. Samples: For each exposed product and for each color and texture specified.

1.3 CLOSEOUT SUBMITTALS

- A. Maintenance data.

PART 2 - PRODUCTS

2.1 ACCORDION FOLDING DOORS

- A. Description: Top-supported, horizontal-sliding, manually operated accordion folding doors, with chain controlling the spacing and extension of pantographic or X-type accordion folding frames; 2-3/4 lb/sf hanging weight.
 1. Basis of Design: Modernfold #1200 or approved equal.
- B. Partition Finishes:
 1. Finish: Reinforced heavy-duty vinyl with woven backing weighing not less than 30 ounces per lineal yard.
 2. Partition Trim: Exposed sweep strips of one consistent color.
- C. Construction: Shall consist of steel hinge plates welded to 3/16 inch diameter vertical steel rods, with a single row of plates at the bottom and double row of hinge plates at the top. A high tensile alloy steel trolley yoke, functioning as a hinge pin at required intervals, supports the frame assembly.

**KOPACHUCK STATE PARK
DAY USE DEVELOPMENT**

D. Hardware:

1. Grip type hand pulls shall be die cast zinc, satin chrome finish.

E. Suspension System:

1. Suspension system, track and trolley sizes matched to the size of partition.
 - a. Suspension Track: Shall be a continuous “C” channel shaped track, connected to the structural support.
 - b. Carriers: The accordion folding partition shall be suspended from the track by two wheel intermediate and four wheel lead trolley assemblies.

PART 3 - EXECUTION

3.1 INSTALLATION

- A. General: Install accordion folding doors complying with manufacturer's written installation instructions. Install track in one piece.
- B. Standard Floor Clearances: 1/4 to 3/4 inch maximum (above floor finish).

END OF SECTION 083513

**KOPACHUCK STATE PARK
DAY USE DEVELOPMENT**

SECTION 083613 - SECTIONAL DOORS

1.1 SUMMARY

- A. Commercial, glazed aluminum-framed sectional doors with solid bottom section.

1.2 Electric operators and controls.

- A. Operating hardware, tracks, support and accessories required for complete installation.

1.3 REFERENCES

- A. Applicable provisions of the most recent adopted editions of the following standards shall apply to the work of this Section, except as modified herein, and are hereby made a part of these Contract Specifications to the extent required:

1. ASTM A229 Standard Specifications for Steel Wire, Quenched and Tempered for Mechanical Springs
2. ASTM A653 Standard Specification for Steel Sheet, Zinc-Coated (Galvanized) or Zinc-Iron Alloy-Coated (Galvannealed) by the Hot-Dip Process
3. DASMA 102 Specifications for Sectional Type Doors
4. DASMA 105 Test Method for Thermal Transmittance and Air Infiltration of Garage Doors
5. DASMA 109 Standard Method for Testing Garage Doors: Determination of Life Cycling Performance

1.4 ADMINISTRATION REQUIREMENTS

- A. Coordination: Coordinate installation of electrical service, power and control wiring from disconnect to door units.
- B. Pre-Installation Meeting: Convene prior to installation of doors to establish procedures and to coordinate this work with related and adjacent work.

1.5 ACTION SUBMITTALS

- A. Product Data: Manufacturer's product data.
 1. Include summary of forces and loads on beams, walls and jambs.
 2. Manufacturer's installation instructions.
- B. Shop Drawings: For each installation and for special components not dimensioned or detailed in manufacturer's product data. Include:
 1. Plans, elevations, details of framing members, anchorages, and accessories.
 2. Relationship with adjacent materials and required clearances.

**KOPACHUCK STATE PARK
DAY USE DEVELOPMENT**

3. Summary of forces and loads on beams, walls, and jambs.
4. Setting drawings, templates, and installations for built-in or embedded anchor devices.
5. Indicate field-verified dimensions on Shop Drawings.

C. Samples: For each exposed product and for each color and texture specified.

1.6 CLOSEOUT SUBMITTALS

A. Include door operation and maintenance data in the Operation and Maintenance Manual.

1.7 QUALITY ASSURANCE

A. Installer Qualifications: Shall have a minimum of 5 years experience specializing in the installation of overhead sectional doors.

1. Shall be an authorized representative of the sectional overhead door manufacturer.

B. Manufacturer Qualifications: Shall be a company specializing in the manufacturing of overhead sectional doors, with a minimum of 5 years experience in producing doors of type and quality specified.

C. Regulatory Requirements:

1. Comply with Washington State Energy Code.

a. NFRC-certified and labeled.

b. Products Requiring Electrical Connections: Listed and classified by U.L., suitable for the purpose specified.

PART 2 - PRODUCTS

2.1 MANUFACTURERS AND PRODUCTS

A. Manufacturers: Northwest Door, Overhead Door Company, Raynor, or approved equal.

B. Product: Basis of Design: Northwest Door, Tel. (253) 537-2266, www.nwdusa.com ; Model "800 Door", industrial grade overhead door specified for type, quality and performance.

2.2 OVERHEAD SECTIONAL DOORS

A. Overhead Sectional Doors: Glazed aluminum framed overhead sectional doors with solid bottom section.

1. Operation: Electric.

2. Track Type: Lift type as required for conditions.

3. Sizes: As indicated on Drawings.

4. Door Thickness: 2 inches.

**KOPACHUCK STATE PARK
DAY USE DEVELOPMENT**

5. Dimensions:
- a. Top and Bottom Rails: 5-7/8 inch (5-1/2 inch face width)
 - b. Meeting Rails: 4-3/16 inch overall width combined (3-1/2 inch face width).
 - c. End Stiles: 5-7/8 inch overall width (5-1/2 inch face width).
 - d. Center Stiles: 3-1/4 inch overall width (2-1/2 inch face width)

B. Performance Requirements:

- 1. Overall sectional doors shall conform to requirements of referenced DASMA 102, 105 and 109.
- 2. Operation: High cycle torsion springs tested to 75,000 cycles.
- 3. Structural Performance: Doors shall be capable of withstanding the effects of gravity loads and the following loads and stresses without evidencing permanent deformation of door components.
 - a. Wind Load: Uniform pressure (velocity pressure) of 20 lbf/sq. ft., acting inward and outward. See also, Structural General Notes and DASMA 102.
 - b. Maximum Deflection (door in open position): 1/120th of door width.
- 4. Comply with Washington State Energy Code
 - a. NFRC-certified.

C. Panel Materials/Construction:

- 1. Frame, Stiles and Rails: Commercial grade, extruded aluminum, 6053-T6.
- 2. Panels:
 - a. Panel Materials: 0.050 inch thick, smooth aluminum sheet.
 - b. Panel Metal Finish: #602 Bronze Anodized
 - c. Insulated Bottom Section: Solid full width, painted section, insulated ½ inch thick polyurethane, CFC-free and HCFC-free, fully encapsulated.
 - d. Vision Lites: Full panel width. Insulating glazing, ½ thick overall thickness (1/8 inch Low-E tempered glazing, ¼ inch argon filled; 1/8 inch tempered glazing).
- 3. Section Joint: Sections form weathertight shiplap fit.

2.3 COMPONENTS AND ACCESSORIES

- 1. Tracks: Continuous 3 inch wide, hemmed and bracket mounted track per side, 12 gauge galvanized steel, and to suit loading required and clearances available. Galvanized steel mounting brackets.
 - a. Mounting: Interior face mounted on a prepared surface as indicated on Drawings.
 - b. Lift/Track Style: Follow roof slope.
- 2. Hinges: 14 gauge galvanized, heavy-duty double end hinges and long stem rollers.
- 3. Roller Assemblies: Sealed heavy-duty adjustable, stainless steel bearing rollers.

**KOPACHUCK STATE PARK
DAY USE DEVELOPMENT**

4. Lift Mechanism: Torsion spring on cross head shaft, with braided galvanized steel lifting cables.
5. Weatherstripping:
 - a. Panel Joints: Flexible compressible seal, one piece full length.
 - b. Head and Jamb: Resilient weatherstripping as recommended by door manufacturer for application and mounting type/surfaces.
 - c. Sill: One piece, U-shaped loop type extruded vinyl with full-length contact.
 - d. Locking: Rim cylinder and lock, coordinate with Owner's keying system specified in Section 08 71 00, Door Hardware.

2.4 ELECTRICAL OPERATION

A. Electrical-General:

1. Refer to Electrical Drawings.
2. Wiring Connections: Refer to Electrical Drawings.
3. Disconnect Switch: Factory mount disconnect switch.

B. Electric Operation: Electric door operator assembly of size and capacity recommended for minimum "operation cycles" indicated with NEMA MG1 electric motor and factory-prewired motor controls, starter, gear-reduction unit, solenoid-operated brake, clutch, remote-control stations, control devices, integral gearing for locking door, interlocking switch, and accessories required for proper operation.

1. U.L. listed electric door operator.

C. Operator Controls: Surfaced mounted, push-button operated control; stations with open, close, and stop buttons; and key operated switch. Confirm locations with Architect.

D. Safety Edge: Full width, at bottom of door panel; sensitized type, wired to stop and reverse door upon striking object; covered to provide weatherstrip seal.

PART 3 - EXECUTION

3.1 EXAMINATION

- A. Verify installation conditions as satisfactory to receive work of this Section. Do not install until unsatisfactory conditions are corrected. Beginning work constitutes acceptance of conditions as satisfactory.
- B. Verify electric power is available and of correct characteristics.

**KOPACHUCK STATE PARK
DAY USE DEVELOPMENT**

3.2 INSTALLATION

- A. Install sectional doors and operating equipment complete with necessary hardware, anchors, inserts, hangers, and equipment supports; according to manufacturer's written instructions and as specified.
- B. Tracks: Provide sway bracing, diagonal bracing, and reinforcement as required for rigid installation of track and door-operating equipment.
- C. Accessibility: Install sectional doors, switches, and controls along accessible routes in compliance with regulatory requirements for accessibility.
- D. Adjust hardware and moving parts to function smoothly so that doors operate easily, free of warp, twist, or distortion.
- E. Touch-up damaged finishes and repair minor damage; clean frames and glass.

3.3 DEMONSTRATION

- A. Engage a factory-authorized service representative to train Owner's maintenance personnel to adjust, operate, and maintain sectional doors.

END OF SECTION 083613

**KOPACHUCK STATE PARK
DAY USE DEVELOPMENT**

SECTION 084313 – ALUMINUM FRAMED STOREFRONT

PART 1 - GENERAL

1.1 SECTION INCLUDES

- A. Exterior storefront and entrance.
- B. Interior storefront and entrance.

1.2 RELATED REQUIREMENTS

- A. 076200 - Sheet Metal Flashing and Trim: for adjacent flashings and trim.
- B. 072500 - Weather Barriers: for adjacent components of continuous building air barrier requiring tie into work of this section.
- C. 088000 - Glazing.

1.3 SUBMITTALS

- A. Qualification Data: For manufacturer, installer and design engineer.
- B. Energy Performance Certificates: NFRC Label Certificates are required for this project including project specific, frame types, spacer types and glass types as specified in Section 088000 - Glazing. Project specific reports substantiate U-value, visual light transmission, and solar heat gain values required by the Energy Code for the project. Provide NFRC certificates for compliance documentation for the installed windows.
- C. Product Data: Provide product criteria, characteristics, accessories, material descriptions, dimensions of individual components and profiles, and finishes.
- D. Shop Drawings: For glazed storefronts. Include plans, elevations, sections, full-size details, and attachments to other work.
 - 1. Include details of provisions for assembly expansion and contraction and for draining moisture occurring within the assembly to the exterior.
 - 2. Include full-size isometric details of each vertical-to-horizontal intersection of glazed Storefronts, showing the following:
 - a. Joinery, including concealed welds.
 - b. Anchorage templates and details.
 - c. Interface with adjoining building construction
 - d. Referenced to detail numbers indicated on the Contract Drawings
 - e. Expansion and seismic provisions.
 - f. Entrance Systems
 - g. Glazing.

**KOPACHUCK STATE PARK
DAY USE DEVELOPMENT**

h. Flashing and drainage.

E. Product Test Reports:

1. Based on evaluation of comprehensive tests performed by a qualified preconstruction testing agency, for glazed storefronts, indicating compliance with performance requirements.

F. Sample: For each type of exposed finish required, in manufacturer's standard sizes.

G. Manufacturer's Installation Instructions: Indicate special preparation of substrate, installation and attachment methods, and perimeter conditions requiring special attention.

H. Warranty: Submit manufacturer warranty and ensure forms have been completed in Owner's name and registered with manufacturer.

I. Maintenance Data: For users operation and maintenance of system including:

1. Methods for maintaining system's materials and finishes.
2. Precautions about cleaning materials and methods that could be detrimental to components, finishes, and performance.
3. Recommendations on maintenance schedule.
4. Include ASTM C 1401 recommendations for post installation-phase quality-control program.

1.4 QUALITY ASSURANCE

A. Manufacturer Qualification: Company specializing in the manufacture of work specified in this section with minimum 5 years experience.

B. Designer Qualifications: Professional structural engineer with 5 years of documented experience in design of this work and licensed in the location of the project.

C. Installer Qualifications: Company specializing in performing the work of this section with minimum 5 years experience on projects of similar size and complexity.

1.5 DELIVERY, STORAGE, AND HANDLING

A. As required by the manufacturer for a warrantable installation of the installed products to meet the Performance and Design Criteria.

**KOPACHUCK STATE PARK
DAY USE DEVELOPMENT**

1.6 WARRANTY

- A. Manufacturer's Finish Warranty: Correct defective work within a 20 year period after Substantial Completion for degradation of panel finish, including color fading caused by exposure to weather.
 - 1. Finish Criteria are listed AAMA 2605.
- B. Manufacturer Warranty: Provide 2 year warranty for system failing to resist penetration of water.

PART 2 - PRODUCTS

2.1 DESCRIPTION

- A. Factory fabricated and finished aluminum framing system with infill, and related flashings, anchorage and attachment devices. Systems do not typically equalize pressure or manage water intrusion within the system and are designed to bear on floor plates and be less than 12 feet tall.
- B. The Drawings:
 - 1. Indicate the design intent for profile, joints and configuration required together with relationship to structural frame and interior building elements.
 - a. Drawings do not purport to identify or solve completely the problems of thermal or structural movement, pressure equalization, weep system, vapor retarder, fixings and anchorage, flatness and stability of facing, or moisture management.
- C. General Performance: Comply with performance requirements specified, as determined by preconstruction testing of manufacturer's standard glazed storefronts representing those indicated for this Project without failure due to defective manufacture, fabrication, installation, or other defects in construction.
 - 1. Glazed storefronts shall withstand movements of supporting structure including, but not limited to, story drift, twist, column shortening, long-term creep, and deflection from uniformly distributed and concentrated live loads.
 - 2. Failure also includes the following:
 - a. Deflection exceeding specified limits.
 - b. Framing members transferring stresses, including those caused by thermal and structural movements to glazing.
 - c. Glazing-to-glazing contact.
 - d. Sealant failure.
 - e. Glass breakage.
 - f. Noise or vibration created by wind and thermal and structural movements.
 - g. Loosening or weakening of fasteners, attachments, and other components.
 - h. Failure of operating units.
- D. Deflection of Framing Members: At design wind pressure, as follows:

**KOPACHUCK STATE PARK
DAY USE DEVELOPMENT**

1. Deflection Normal to Wall Plane: Limited to edge of glass in a direction perpendicular to glass plane not exceeding $L/175$ of the glass edge length for each individual glazing lite or an amount that restricts edge deflection of individual glazing lites to $3/4$ inch, whichever is less.
 - a. For spans over 13 feet 6 inches limit deflection to $L/240 + 1/4$ inch.
2. Deflection Parallel to Glazing Plane: Limited to $L/360$ of clear span or $1/8$ inch, whichever is smaller.
3. Cantilever Deflection: Where framing members overhang an anchor point, limit deflection to two times the length of cantilevered member, divided by 175.

E. Exterior Storefront Performance:

1. U-Value: 0.37 maximum based on project specific frame types, spacer types and glass types.
2. Air Infiltration: Maximum air leakage through fixed glazing and framing areas of 0.04 cfm/sf. ft. of fixed wall area as determined according to ASTM E 283 at a minimum static-air-pressure differential of 6 lbf/sq. ft.
3. Thermal Movements: Allow for thermal movements resulting from the following maximum change (range) in ambient and surface temperatures:
 - a. Temperature Change (Range): 120 deg F, ambient; 180 deg F, material surfaces.
 - b. Test Interior Ambient-Air Temperature: 75 deg F.
 - c. Test Performance: No buckling; stress on glass; sealant failure; or excess stress on framing, anchors, and fasteners; and no reduction of performance when tested according to AAMA 501.5.

2.2 MATERIALS

A. Exterior Storefront

1. Basis of Design Product: Trifab 541UT (Ultra Thermal) by Kawneer.
 - a. Substitutions for products by manufacturers other than those listed above: See Section 016000 - Product Requirements.
2. Performance Criteria:
 - a. U-Value: 0.36 maximum based on project specific opening sizes and configurations with project specific frame types, spacer types and glass types.
 - b. U-Value: 0.36 maximum based on NFRC 100 gateway size with project specific frame types, spacer types and glass types.
 - c. Air Infiltration:
 - 1) Air Infiltration: Maximum air leakage through fixed glazing and framing areas of 0.04 cfm/sf. ft. of fixed wall area as determined according to ASTM E 283 at a minimum static-air-pressure differential of 12 lbf/sq. ft.
 - d. Thermal Movements: Allow for thermal movements resulting from the following maximum change (range) in ambient and surface temperatures:

**KOPACHUCK STATE PARK
DAY USE DEVELOPMENT**

- 1) Temperature Change (Range): 120 deg F, ambient; 180 deg F, material surfaces.
 - 2) Test Interior Ambient-Air Temperature: 75 deg F.
 - 3) Test Performance: No buckling; stress on glass; sealant failure; or excess stress on framing, anchors, and fasteners; and no reduction of performance when tested according to AAMA 501.5.
3. Features:
- a. Framing Members: Manufacturer's standard extruded- or formed-aluminum framing members of thickness required and reinforced as required to support imposed loads.
 - b. Sightline: 2 inches.
 - c. Depth: 4-1/2 inches.
 - d. Center glazed.
 - e. All units to have jamb and head compensating receptors.
 - f. Manufacture to supply matching prefinished break metal for adjacent conditions.
 - g. Finish: Dark bronze anodized aluminum, Architectural Class 1.
- B. Exterior Entrances:
1. Approved manufacturer of entrance system: Kawneer 350 medium stile.
 - a. Substitutions: See Section 016000 - Product Requirements.
 2. Performance Criteria:
 - a. Overall U-value Including Glazing: 0.60 Btu/(hr sq ft deg F), maximum per AAMA 1503.
 3. Features:
 - a. Thickness: 1-23/32 inches.
 - b. Top Rail: 3-1/2 inches .
 - c. Vertical Stiles: 3-1/2 inches wide.
 - d. Bottom Rail: 10 inches wide, ADA accessible doors.
 - e. Glazing Stops: Square.
 - f. Finish: Dark bronze anodized aluminum, Architectural Class 1 (.7 mils minimum)
 4. Hardware: See Section 087100 Door hardware for Storefront.
- C. Glazing:
1. Comply with Section 088000 - Glazing.
 2. Glazing Gaskets, Spacers, Setting Blocks, Sealant Backings, and Bond Breakers: Manufacturer's standard permanent, nonmigrating types compatible with sealants and suitable for joint movement and assembly performance requirements.

**KOPACHUCK STATE PARK
DAY USE DEVELOPMENT**

3. Weather seal sealant: ASTM C 920 for Type S; Grade NS; Class 25; Uses NT, G, A, and O; chemically curing silicone formulation that is compatible with structural sealant and other system components with which it comes in contact;
4. recommended by structural-sealant, weather seal-sealant, and structural-sealant- glazed curtain-wall manufacturers for this use.
 - a. Sealants used inside the weatherproofing system shall have a VOC content of 250 g/L or less when calculated according to 40 CFR 59, Subpart D (EPA Method 24).

2.3 ACCESSORIES

- A. All accessory materials required by the manufacturer for a warrantable installation of the installed products in a manner that meets the Performance and Design Criteria.
- B. Concealed Flashing:
 1. Dead-soft, 0.018-inch- thick stainless steel, ASTM A 240/A 240M of type recommended by manufacturer. or prefinished aluminum only.
- C. Framing Sealants:
 1. Manufacturer's standard sealants with VOC content of 250 g/L or less when calculated according to 40 CFR 59, Subpart D (EPA Method 24). and 100% silicone.
- D. Manufacturer's recommended compensation head channels.

PART 3 - EXECUTION

3.1 EXAMINATION

- A. Verify existing conditions meet the manufacturer's requirements before starting work.

3.2 PREPARATION

- A. Prepare surfaces to receive work in accordance with manufacturer's instructions.

3.3 INSTALLATION

- A. General: Install all materials in accordance with manufacturer's instructions based on conditions present.

3.4 ERECTION TOLERANCES

- A. Erection Tolerances: Install glazed Storefronts to comply with the following non-accumulating maximum tolerances:

**KOPACHUCK STATE PARK
DAY USE DEVELOPMENT**

1. Plumb: 1/8 inch in 10 feet; 1/4 inch in 40 feet.
2. Level: 1/8 inch in 20 feet; 1/4 inch in 40 feet.
3. Alignment:
 - a. Where surfaces abut in line or are separated by reveal or protruding element up to 1/2 inch wide, limit offset from true alignment to 1/16 inch.
 - b. Where surfaces are separated by reveal or protruding element from 1/2 to 1 inch wide, limit offset from true alignment to 1/8 inch.
 - c. Where surfaces are separated by reveal or protruding element of 1 inch wide or more, limit offset from true alignment to 1/4 inch.
4. Location: Limit variation from plane to 1/8 inch in 12 feet; 1/2 inch over total length.
5. Allowances for cumulative effect of all tolerances (fabrication, assembly, thermal, seismic, building and erection) and including the work of other sections, shall be made to ensure a weatherproof installation

3.5 ADJUSTING

- A. Adjust operating hardware, and accessories for smooth function and tight fit at contact points and weather stripping for smooth operation and weathertight closure. Lubricate hardware and moving parts.
 1. For entrance doors accessible to people with disabilities, adjust closers to provide a 3-second closer sweep period for doors to move from a 70-degree open position to 3 inches from the latch, measured to the leading door edge. B. Adjust and lubricate hardware for proper operation.

3.6 PROTECTION

- A. Protect installed work as required by the manufacturer to maintain product performance, design criteria and warranty.

3.7 SCHEDULE

- A. Refer to drawings for storefront types.

END OF SECTION 084313

**KOPACHUCK STATE PARK
DAY USE DEVELOPMENT**

SECTION 085200 - WOOD WINDOWS

PART 1 - GENERAL

1.1 SUMMARY

- A. Section includes aluminum-clad wood windows.

1.2 ACTION SUBMITTALS

- A. Product Data: For each type of product.
- B. Shop Drawings: Include plans, elevations, sections, hardware, accessories, insect screens, operational clearances, and details of installation, including anchor, flashing, and sealant installation.
- C. Samples: For each exposed product and for each color specified.
- D. Compliance Documentation: NFRC certificates for the installed windows.

1.3 INFORMATIONAL SUBMITTALS

- A. Product test reports.
- B. Sample warranties.

1.4 WARRANTY

- A. Manufacturer's Warranty: Manufacturer agrees to repair or replace wood windows that fail in materials or workmanship within specified warranty period.
 - 1. Warranty Period:
 - a. Window: 10 years from date of Substantial Completion.
 - b. Glazing Units: 5 years from date of Substantial Completion.
 - c. Aluminum-Cladding Finish: 20 years from date of Substantial Completion.

1.5 WINDOW PERFORMANCE REQUIREMENTS

- A. Product Standard: Comply with AAMA/WDMA/CSA 101/I.S.2/A440 for definitions and minimum standards of performance, materials, components, accessories, and fabrication unless more stringent requirements are indicated.
 - 1. Window Certification: WDMA certified with label attached to each window.

**KOPACHUCK STATE PARK
DAY USE DEVELOPMENT**

B. Performance Class and Grade: AAMA/WDMA/CSA 101/I.S.2/A440 as follows:

1. Minimum Performance Class: LC.
2. Minimum Performance Grade: 25 psf.

C. Fenestration Product Ratings: U-factors of fenestration shall be as follows:

1. For windows, doors and skylights, U-factor ratings shall be determined in accordance with NFRC 100.

1.6 WOOD WINDOWS

A. Aluminum-Clad Wood Windows:

1. Manufacturer:

- a. Kolbe & Kolbe Millwork Co. Inc., Wausau, Wisconsin, www.kolbewindows.com
- b. Marvin Windows and Doors; Warroad, MN, www.marvin.com

B. Operating Types: Fixed and Slider.

C. Frames and Sashes: Fine-grained wood lumber complying with WDMA I.S. 4-07A; kiln dried to a moisture content of not more than 12 percent at time of fabrication; free of visible finger joints, blue stain, knots, pitch pockets, and surface checks larger than 1/32 inch deep by 2 inches wide; water-repellent preservative treated.

1. Exterior Finish: Aluminum-clad wood.

- a. Aluminum Finish: Manufacturer's standard fluoropolymer two-coat system with fluoropolymer color topcoat containing not less than 70 percent PVDF resin by weight and complying with AAMA 2605.
- b. Color: Dark Bronze Anodized.

2. Interior Finish: Manufacturer's standard stain-and-varnish finish.

- a. Exposed Unfinished Wood Surfaces: Pine with stain and varnish finish.
- b. Stain Color: As selected by Architect from manufacturer's full range.

3. Glazing: See Section 088000 Glazing for glazing requirements.

D. Hardware, General: Provide manufacturer's standard corrosion-resistant hardware sized to accommodate sash weight and dimensions.

1. Exposed Hardware Color and Finish: As selected by Architect from manufacturer's full range.

**KOPACHUCK STATE PARK
DAY USE DEVELOPMENT**

- E. Horizontal-Sliding Window Hardware:
 - 1. Sill Cap/Track: Designed to comply with performance requirements indicated and to drain to the exterior.
 - 2. Locks and Latches: Operated from the inside only.
 - 3. Roller Assemblies: Low-friction design.

- F. Weather Stripping: Provide full-perimeter weather stripping for each operable sash unless otherwise indicated.

- G. Fasteners: Noncorrosive and compatible with window members, trim, hardware, anchors, and other components.
 - 1. Exposed Fasteners: Do not use exposed fasteners to greatest extent possible. For application of hardware, use fasteners that match finish hardware being fastened.

1.7 ACCESSORIES

- A. True Divided Lites: Provide true divided lites in designs indicated for each sash lite.
 - 1. Quantity and Type: As indicated on Drawings.
 - 2. Material: Manufacturer's standard.
 - 3. Pattern: As indicated on Drawings.
 - 4. Profile: As selected by Architect from manufacturer's full range.
 - 5. Color: As selected by Architect from manufacturer's full range.

1.8 FABRICATION

- A. Fabricate wood windows in sizes indicated. Include a complete system for installing and anchoring windows.
- B. Glaze wood windows in the factory.
- C. Weather strip each operable sash to provide weathertight installation.
- D. Complete fabrication, assembly, finishing, hardware application, and other work in the factory to greatest extent possible. Disassemble components only as necessary for shipment and installation. Allow for scribing, trimming, and fitting at Project site.

PART 2 - EXECUTION

2.1 INSTALLATION

- A. Comply with manufacturer's written instructions for installing windows, hardware, accessories, and other components. For installation procedures and requirements not addressed in manufacturer's written instructions, comply with installation requirements in ASTM E2112.

**KOPACHUCK STATE PARK
DAY USE DEVELOPMENT**

- B. Install windows level, plumb, square, true to line, without distortion, anchored securely in place to structural support, and in proper relation to wall flashing and other adjacent construction to produce weathertight construction.
- C. Clean exposed surfaces immediately after installing windows. Remove excess sealants, glazing materials, dirt, and other substances.
- D. Remove and replace sashes if glass has been broken, chipped, cracked, abraded, or damaged during construction period.

END OF SECTION 085200

**KOPACHUCK STATE PARK
DAY USE DEVELOPMENT**

SECTION 086200 - UNIT SKYLIGHTS

PART 1 - GENERAL

1.1 SUMMARY

A. Section Includes:

1. Aluminum skylight framing system.
2. Skylight glazing.
3. Fasteners, anchors, reinforcement, and flashings.

1.2 ACTION SUBMITTALS

- A. Product Data: For each type of unit skylight.
- B. Shop Drawings: For unit skylight work. Include plans, elevations, sections, details, and connections to supporting structure and other adjoining work.
- C. Samples: For each type of exposed finish required and each type of glazing.

1.3 INFORMATIONAL SUBMITTALS

- A. Qualification data.
- B. Product test reports.
- C. Field quality-control reports.
- D. Sample warranty.

1.4 CLOSEOUT SUBMITTALS

- A. Maintenance data.

1.5 WARRANTY

- A. Special Warranty: Manufacturer agrees to repair or replace components of unit skylights that fail in materials or workmanship within specified warranty period.
 1. Warranty Period: Ten years from date of Substantial Completion.

**KOPACHUCK STATE PARK
DAY USE DEVELOPMENT**

PART 2 - PRODUCTS

2.1 MANUFACTURERS

- A. Kingspan; Custom Metal Framed Skylights or approved equal.

2.2 METAL FRAMED SKYLIGHTS

- A. Metal Framed Skylights: Factory-fabricated, glazed.
1. Frame: Extruded aluminum structural members with integral condensation collection and guttering system thermally separated from exterior pressure bar.
 2. Glazing System: Pressure glazing bar system for sloped joints and two (2) sided structural sealant glazing (SSG) for horizontal joints.
 3. Glazing: Insulating glass.
 4. Aluminum Finish: Class 1 natural anodized.
 5. Fabricated to prevent harmonic vibration, wind whistles, noises caused by thermal movement, thermal movement transmitted to other building elements, loosening, weakening, or fracturing of attachments or components of system.
- B. Performance Requirements: Provide products that comply with the following:
1. Structural Design: Design and size components to withstand dead loads and specified live loads without damage or permanent set.
 2. Wind Loads: test in accordance with ASTM E330/E330M, using loads 1.5 times the specified design pressures and 10 second duration of maximum load.
 3. Glazing Support Member Deflection Under Wind Load: 1/180 of span, maximum.
 4. Thermal Movement: Design system to accommodate thermal expansion and contraction over ambient temperature range of 100 degrees F, dynamic loading and release of load, creep, of concrete structural members and deflection of structural support framing without damage to skylight system components or loss of weathertightness.
 5. Air Leakage: Limit air infiltration through assembly to 0.06 cu. Ft./min./sq. ft. for glazed area, measured at a reference differential pressure across assembly of 1.57 psf in accordance with ASTM E283.
 6. Water Leakage: None, when measured in accordance with ASTM E 331 at a test pressure difference of 2.86 lbf/sq. ft.

2.3 MATERIALS

- A. Aluminum Extrusions: Alloy and temper 6063-T5, 6063-T6, or 6061-T6 members complying with ASTM B221 (ASTM B221M), with minimum thickness 1/8 inch for structural members and 1/16 inch for non-structural members.
- B. Formed Aluminum: Sheet material of alloy 5052, 5005, or 6061-T651 members complying with ASTM B209 (ASTM B209M), with minimum thickness 1/8 inch for structural members and 1/16 inch for non-structural members.
- C. Internal Reinforcement: ASTM A36/A36M; Steel shapes as required for strength and mullion size limitations, hot-dip galvanized after fabrication in accordance with ASTM A123/A123M.

**KOPACHUCK STATE PARK
DAY USE DEVELOPMENT**

- D. Insulating Glass: Sealed insulated units (U-0.78), outer pane of transparent, laminated glass; inner pane of clear transparent, laminated glass; space of sealed air, metal edge frame.
- E. Glazing Accessories: As recommended by manufacturer of skylight system.
- F. Weatherseal Sealant: Silicone, with adhesion in compliance with ASTM C794; compatible with glazing accessories
- G. Touch-Up Primer for Galvanized Steel Surfaces: Zinc rich type.
- H. Fasteners: Stainless steel.
- I. Anchorage Devices: Type recommended by manufacturer, exposed to view.
- J. Thermal Break: Fabricate unit skylights with thermal barrier separating exterior and interior metal framing.
- K. Fasteners: Same metal as metal being fastened, nonmagnetic stainless steel, or other noncorrosive metal as recommended by manufacturer. Finish exposed fasteners to match material being fastened. Provide nonremovable fastener heads.

2.4 FABRICATION

- A. Rigidly fit and secure joints and corners with screw and spline. Make joints rigid, with connections that are flush, hairline, and weatherproof.
- B. Fabricate components to allow for expansion and contraction with minimum clearance and shim spacing around perimeter of assembly.
- C. Drain to exterior any water entering exterior joints, condensation occurring within system.
- D. Prepare components to receive concealed anchorage devices will be concealed upon completion of installation.

2.5 FINISHES

- A. Class 1 Natural Anodized Finish: AAMA 611 AA-M12C22A41 Clear anodic coating not less than 0.7 mils thick; exterior surfaces only.

PART 3 - EXECUTION

3.1 INSTALLATION

- A. Coordinate installation of unit skylight with installation of substrates, vapor retarders, roof insulation, metal roofing, and flashing as required to ensure that each element of the Work performs properly and that combined elements are waterproof and weathertight.

**KOPACHUCK STATE PARK
DAY USE DEVELOPMENT**

- B. Comply with recommendations in AAMA 1607 and with manufacturer's written instructions for installing unit skylights.

3.2 CLEANING

- A. Clean exposed unit skylight surfaces according to manufacturer's written instructions. Touch up damaged metal coatings and finishes.

END OF SECTION 086200

**KOPACHUCK STATE PARK
DAY USE DEVELOPMENT**

SECTION 087100 - DOOR HARDWARE

PART 1 - GENERAL

1.1 SUMMARY

A. Section Includes:

1. Mechanical door hardware for the following:
 - a. Swinging doors.

1.2 PREINSTALLATION MEETINGS

- A. Preinstallation Conference: Conduct conference at Project site.

1.3 ACTION SUBMITTALS

- A. Product Data: For each type of product.
- B. Samples: For each exposed product in each finish specified.
- C. Door hardware schedule.
- D. Keying schedule.

1.4 CLOSEOUT SUBMITTALS

- A. Maintenance data.

1.5 QUALITY ASSURANCE

- A. Installer Qualifications: Supplier of products and an employer of workers trained and approved by product manufacturers and of an Architectural Hardware Consultant who is available during the course of the Work to consult Contractor, Architect, and Owner about door hardware and keying.
1. Scheduling Responsibility: Preparation of door hardware and keying schedule.

**KOPACHUCK STATE PARK
DAY USE DEVELOPMENT**

- B. Architectural Hardware Consultant Qualifications: A person who is experienced in providing consulting services for door hardware installations that are comparable in material, design, and extent to that indicated for this Project and who is currently certified by DHI as an Architectural Hardware Consultant (AHC).

1.6 WARRANTY

- A. Special Warranty: Manufacturer agrees to repair or replace components of door hardware that fail in materials or workmanship within specified warranty period.
1. Warranty Period: **3** years from date of Substantial Completion unless otherwise indicated below:
 - a. Exit Devices: 3 years from date of Substantial Completion.
 - b. Manual Closers: 10 years from date of Substantial Completion.
 - c. Locksets: 3 years from date of Substantial Completion.

PART 2 - PRODUCTS

2.1 HINGES

- A. Hinges: BHMA A156.1. Provide template-produced hinges for hinges installed on hollow-metal doors and hollow-metal frames. Three hinges per leaf to 7 feet, 6 inch height. Add one each additional 30 inches in height or any fraction thereof. Provide 4 ½ x 4 ½ for 1 ¾" thick doors up to 36". Provide 5 x 4 ½ heavy weight on doors over 36". Exterior outswing doors to have non removable (NRP) pins. Pin tips, flat button, finish to match leaves.
1. Mfr: (IVES) Ives
 2. Acceptable Sub: McKinney, Hager

2.2 MECHANICAL PUSHBUTTON LOCKS

- A. Mechanical pushbutton locks: BHMA Grade heavy-duty mortise lock housing with cast front housing, unified trim, weatherproof, and fixed ADA compliant levers, panic-free inside lever. Vandal resistant, solid metal numeric keypad 12 push buttons. Satin chrome 26D finish. Provide Best core.

Mfr.: Trilogy T2 DL2700 Mortise weatherproof commercial lock

**KOPACHUCK STATE PARK
DAY USE DEVELOPMENT**

2.3 EXIT DEVICES

- A. Exit Devices: BHMA A156.3., Grade 1, Cross bar design, field reversable, field sizable; ¾” throw deadbolting latchbolts; releasable with 32 lb. maximum pressure under 250 lb. load to the door.
1. Mfr:(VON) Von Duprin
 2. Acceptable Sub: Precision, Sargent

2.4 LOCKSETS, LATCHSETS, DEADBOLTS

- A. Mortise Locksets and Latchsets: as scheduled.
1. Steel case with ¾” throw stainless steel anti-friction latchbolt and a 1” throw stainless steel deadbolt.
 2. Levers shall be forged brass, bronze, or cast stainless steel.
 3. Lock shall be field reversible, without opening the case.
 4. Lock trim shall incorporate individual lever support springs in each rose or escutcheon. Lever connection by attaching threaded bushings tightened by a spanner wrench. Threaded set screws will not be accepted. Lock spindles shall be two independent inside and outside spindles to prevent manipulation of lock.
 5. Strikes: 16 gage curved steel, bronze or brass with 1 inch deep box construction, lips of sufficient length to clear trim and protect clothing.
 6. Certifications:
 - a. ANSI A156, 1994, Grade 1 Operational, Grade 1 Security.
 7. Scheduled Lock Series and Design: Schlage L Series, 06A design.

2.5 KEYING

- A. All cylinder items shall be master-keyed into the Park Alike Group and grand-master-keyed. Provide one key for each lock. Keying information will be given to a licensed and bonded locksmith person only. The locksmith shall call Ryan Layton (509) 665-4313 to make keying arrangements.

2.6 SURFACE CLOSERS

- A. Surface Closers: 4010/4011
1. Full rack-and-pinion type cylinder with removable non-ferrous cover and cast iron body. Double heat-treated pinion shaft, single piece forged piston, chrome-silicone steel string.
 2. ISO 2000 certified. Units stamped with date-of-manufacture code.
 3. Independent lab-tested 10,000,000 cycles.
 4. Thru-bolts at all wood doors unless doors are provided with closer blocking. Non-sized and adjustable. Place closers inside the building and rooms.

**KOPACHUCK STATE PARK
DAY USE DEVELOPMENT**

5. Plates, brackets and special templating when needed for interface with particular header, door, and wall conditions and neighboring hardware.
6. Opening pressure: Exterior doors 10 pounds; interior doors 5 pounds.
7. Separate adjusting valves for closing speed, latching speed and backcheck, fourth valve for delayed action where scheduled.
8. Extra-duty arms (EDA) at exterior doors scheduled with parallel arm units.
9. Exterior door closers: tested to 100 hours of ASTM B117 salt spray test, furnish data on request.
10. Exterior doors do not require seasonal adjustments in temperatures from 120 degrees F to minus 30 degrees F.
11. Non-flaming fluid will not fuel door or floor covering fires.

2.7 HEAVY DUTY OFFSET HUNG DOOR CLOSER

1. Mfr: Rixson. Model 27 Heavy Duty Offset Floor Closer

2.8 OTHER HARDWARE

- A. Thresholds: Except as otherwise indicated, provide standard metal threshold unit of type, size, and profile as scheduled.
1. Mfr: (ZER) Zero
 2. Acceptable Sub: Pemko
- B. Door Stops: Provide stops to protect walls, casework or other hardware. See hardware groups.
1. Mfr: (IVES) Ives
 2. Acceptable Sub: Hager, Trimco
- C. Weatherstrip and Gasket: Provide continuous weather-strip gasketing on exterior doors and provide smoke, light, or sound gasketing on interior doors where indicated or scheduled. Provide non-corrosive fasteners as recommended by the manufacturer for the manufacture for application indicated
1. Mfr: (ZER) Zero
 2. Acceptable Sub: Pemko.
- D. Silencers: Interior hollow metal frames, 3 for single doors, 6 for pair of doors.
1. Mfr: (IVES) Ives
 2. Acceptable Sub: Hager, Trimco
- E. Kick Plates: Four beveled edges, .050 inches minimum thickness, height and width as scheduled. Sheet-metal screws of bronze or stainless steel to match other hardware.
1. Mfr: (IVES) Ives
 2. Acceptable Sub: Hager, Trimco

**KOPACHUCK STATE PARK
DAY USE DEVELOPMENT**

2.9 HARDWARE FINISH

- A. Provide the following finishes unless noted differently in hardware groups.
1. Hinges, Exterior 630 Stainless Steel, Interior 626 Dull Chrome
 2. Locksets 626 Dull Chrome
 3. Exit Devices 626 Dull Chrome
 4. Closers Stainless Steel
 5. Other hardware 626 Dull Chrome
 6. Thresholds Aluminum
 7. Weatherstrips/sweeps Aluminum

PART 3 - EXECUTION

3.1 INSTALLATION

- A. Factory trained, certified, and carries a factory-issued card certifying that person as a “Certified Installer”. Alternative: Can demonstrate suitably equivalent competence
- B. Install hardware per manufacturer’s instructions and recommendations. Do not install surface mounted items until finishes have been completed on substrate. Set units level, plumb, and true to line and location. Adjust and reinforce attachment substrate for proper installation and operation.
- C. Locate floor stops not more than 4 inches from the wall.
- D. Drill pilot holes for fasteners in wood doors and/or frames.

3.2 ADJUSTING

- A. Adjust and check each operating item of door hardware and each door to ensure proper operation or function of every unit. Replace units that cannot be adjusted to operate as intended. Adjust door control devices to compensate for final operation of heating and ventilating equipment and to comply with referenced accessibility requirements.

3.3 DOOR HARDWARE GROUPS

HW 1

3	EA HINGE	5BB1 4.5 x 4.5	652	IVE
1	EA FACULTY	L9485L 06A L583-363 L283-722	625	SCH
1	EA MORTISE CYLINDER	1E74 C265 RP3	626	BES

**KOPACHUCK STATE PARK
DAY USE DEVELOPMENT**

1	EA	SURFACE CLOSER	4021	689	LCN
1	EA	KICKPLATE	8400 10"x2"LDW B-CS	630	IVE
1	EA	MOP PLATE	8400 4"x2"LDW B-CS	630	IVE
1	EA	WALL STOP	WS401 CVX	626	IVE
1	EA	GASKETING	188S-BK	S-Bk	ZER

HW 2

6	EA	HINGE	5BB1 4.5 x 4.5	652	IVE
2	EA	MANUAL FLUSH BOLT	FB458	626	IVE
1	EA	DUST PROOF STRIKE	DP2	626	IVE
1	EA	STOREROOM LOCK	L9080L 06A	626	SCH
1	EA	MORTISE CYLINDER	1E74 6265 RP3	626	BES
1	EA	OH STOP	450S	630	GLY
1	EA	SURFACE CLOSER	4111 EDA ST-2732	689	LCN
3	EA	SILENCER	SR 64	GRAY	IVE

HW 3

3	EA	HINGE	5BB1 4.5x4.5	652	IVE
1	EA	OFFICE/ENTRY LOCK	L9050L 06A	626	SCH
1	EA	SURFACE CLOSER	4011	689	LCN
1	EA	KICKPLATE	8400 8"x2" LDW B-C3	630	IVE
1	EA	WALL STOP	WS 401 CVX	626	IVE
1	EA	GASKETING	188S-Bk	S-Bk	ZER

NOTE: AT DOOR 101A, PROVIDE MECHANICAL PUSHBUTTON LOCK TRILOGY T2
DL2700 MORTISE

**KOPACHUCK STATE PARK
DAY USE DEVELOPMENT**

HW 4

3	EA	HINGE	5 BB1 4.5x4.5	652	IVE
1	EA	STOREROOM LOCK	L9080L 06A	626	SCH
1	EA	MORTISE CYLINDER	1E74 C265 RP3	626	BES
1	EA	KICKPLATE	8400 10"x2" LDW B-CS	630	IVE
1	EA	SURFACE CLOSER	4111 SCUSH	626	IVE
3	EA	SILENCER	SR64	GRY	IVE

HW 5

3	EA	HINGE	5 BB1 4.5x4.5	652	IVE
1	EA	PANIC HARDWARE	35A-L-06	626	VON
1	EA	RIM CYLINDER	1E72 S2 RP3	626	BES
1	EA	SURFACE CLOSER	4021	689	LCN
1	EA	ARMOR PLATE	8400 30" x 2" LDW B-CS	630	IVE
3	EA	SILENCER	SR64	GRY	IVE
1	EA	MECH. PUSHBUTTON LOCK	T2 DL2700 MORTISE		TRILOGY

HW 6

6	EA	HINGE	5BB1 4.5 x 4.5 NRP	652	IVE
1	EA	PANIC HARDWARE	3527A-EO-LBR-ER36	626	VON
1	EA	PANIC HARDWARE	3527A-L-LBR-ER 36-06	626	VON
1	EA	RIM CYLINDER	1E72 S2 RP3	626	BES
2	EA	SURFACE CLOSER	4021	689	LCN
2	EA	DOOR SWEEP	8198AA	AA	ZER
1	EA	THRESHOLD	655A-MSLA-10	A	ZER

**KOPACHUCK STATE PARK
DAY USE DEVELOPMENT**

2	EA	GASKETING	188S-Bk	S-Bk	ZER
1	EA	MEETING STILE	328AA	AA	ZER

HW 7

2		SET OFFSET PIVOT	147x JTMS	613	RIXSON
2	EA	INTERMEDIATE PIVOT	M19xJTMS	613	RIXSON
2	EA	EXIT DEVICE	ED5000xF457 M54 M5236x84	613	CORBIN
2	EA	CYLINDER	1080-114-A01	613	CORBIN
2	EA	CYLINDER	3080-178-6	613	CORBIN
1	EA	PULL	CO-9	TBD	KAWNEER
2	EA	CLOSER	DC2220 A3 M54 M72	689	CORBIN
1	EA	MECH. PUSHBUTTON LOCK	T2 DL2700 MORTISE		TRILOGY
1	EA	THRESHOLD	655A-MSLA-10	A	ZER
2	EA	DOOR SWEEP	8198AA	AA	ZER

GASKET BY DOOR SUPPLIER

HW 8

6	EA	HINGE	5BB1 4.5 x 4.5 NRP	630	IVE
1		SET AUTO FLUSH BOLT	FB 31P	630	IVE
1	EA	DUST PROOF STRIKE	DP2	626	IVE
1	EA	STOREROOM LOCK	L9080L 06 A	626	SCH
1	EA	MORTISE CYLINDER	1E74 C 265 RP3	626	BES
1	EA	COORDINATOR	COR x FL	628	IVE
2	EA	SURFACE CLOSER	4111 SCUSH	689	LCN
2	EA	KICKPLATE	8400 10"x1" LDW B-CS	630	IVE

**KOPACHUCK STATE PARK
DAY USE DEVELOPMENT**

1	EA	GASKETING	188S-BK	S-Bk	ZER
1	EA	MEETING STILE	44A	A	ZER
2	EA	DOOR SWEEP	8198AA	AA	ZER
1	EA	THRESHOLD	655A-MSLA-10	A	ZER
1	EA	RAIN DRIP	142A	A	ZER

HW 9

3	EA	HINGE	5BB1 4.5 x 4.5 NRP	630	IVE
1	EA	STOREROOM LOCK	L9080L 06A	626	SCH
1	EA	MORTISE CYLINDER	1E74 C265 RP3	689	BES
1	EA	SURFACE CLOSER	4111 SCUSH	689	LCN
1	EA	KICKPLATE	8400 10"x1" LDW B-CS	630	IVE
1	EA	GASKETING	188S-BK	S-Bk	ZER
1	EA	DOOR SWEEP	8198AA	AA	ZER
1	EA	THRESHOLD	655A-MSLA-10	A	ZER
1	EA	RAIN DRIP	142A	A	ZER

HW 10

3	EA	HINGE	5BB 4.5 x 4.5 NRP	630	IVE
1	EA	MECHANICAL PUSHBUTTON LOCK		625	SCH
1	EA	MORTISE CYLINDER	1E74 C265RP3	626	BES
1	EA	SURFACE CLOSER	4011H	689	LCN
1	EA	KICKPLATE	8400 10"x2" LDW B-CS	630	IVE
1	EA	MOP PLATE	8400 4"x2" LDW B-CS	630	IVE
1	EA	DOOR SWEEP	8198AA	AA	ZER
1	EA	THRESHOLD	655A-MSLA-10	A	ZER

**KOPACHUCK STATE PARK
DAY USE DEVELOPMENT**

1	EA	RAINDRIP	142A	A	ZER
1	EA	GASKETING	188S-Bk	S-Bk	ZER

HW 11

HARDWARE BY OVERHEAD COILING DOOR MANUFACTURER

HW 12

HARDWARE BY OVERHEAD SECTIONAL DOOR MANUFACTURER

HW 13

4	EA	HINGE	5BB1 4.5 x 4.5 NRP	630	IVE
1	EA	ENTRANCE W/DEADBOLT	L9453L 06A L583-363	626	SCH
1	EA	MORTISE CYLINDER	1E74 C265 RP3	626	BES
1	EA	SURFACE CLOSER	4021	689	LCN
1	EA	DOOR SWEEP	8198AA	AA	ZER
1	EA	THRESHOLD	655A-MSLA-10	A	ZER
1	EA	KICKPLATE	8400 10" x 2" LDW B-CS	630	IVE
1	EA	RAIN DRIP	142A	A	ZER

HW 14

3	EA	HINGE	5BB1 4.5 x 4.5 NPR	630	IVE
1	EA	OFFICE/ENTRY LOCK	L9050L 06A	626	SCH
1	EA	MORTISE CYLINDER	1E74 C265 RP3	626	BES
1	EA	GASKETING	188S-BK	S-Bk	ZER

**KOPACHUCK STATE PARK
DAY USE DEVELOPMENT**

1	EA	SURFACE CLOSER	4021	689	LCN
HW 15					
4	EA	HINGE	5BB1 4.5 x 4 NRP	630	IVE
1	EA	RIM CYLINDER	1E72 S2 RP3	626	BES
1	EA	SURFACE CLOSER	4111 SCUSH	689	LCN
1	EA	ARMOR PLATE	8400 30" x 2" LDW B-CS	630	IVE
1	EA	GASKETING	188S-BK	S-Bk	ZER
1	EA	DOOR SWEEP	8198AA	AA	ZER
1	EA	THRESHOLD	655A-MSLA-10	A	ZER
1	EA	RAIN DRIP	142A	A	ZER

END OF SECTION 087100

**KOPACHUCK STATE PARK
DAY USE DEVELOPMENT**

SECTION 088000 - GLAZING

PART 1 - GENERAL

1.1 SECTION INCLUDES

- A. Glass glazing.
- B. Insulating glazing units.
- C. Integrated glass assembly with integral horizontal louver blinds.

1.2 RELATED REQUIREMENTS

- A. 081416 - Flush Wood Doors: for assembly requiring components from this section.
- B. 084313 - Aluminum-Framed Storefronts: for assembly requiring components from this section.
- C. 081113- Hollow Metal Doors and Frames

1.3 SUBMITTALS

- A. Qualification Data: For Installer, fabricator and design engineer.
- B. Delegated-Design Submittal: For assemblies indicated to comply with performance requirements and design criteria, including analysis data signed and sealed by the qualified professional engineer responsible for their preparation.
- C. Product Data:
 - 1. Glass Types: Provide structural, physical and environmental characteristics, size limitations, special handling or installation requirements.
 - 2. Glazing Compounds & Accessories: Provide chemical, functional, and environmental characteristics, limitations, special application requirements and identify available colors.
- D. Shop Drawings: For any glazing installed with components from this section alone.
 - 1. Submit shop drawings for glazing installed within other systems in accordance with the system submittal requirements.

**KOPACHUCK STATE PARK
DAY USE DEVELOPMENT**

- E. Sample: Submit two samples in manufacturer's standard size of glass type units, showing coloration and design.
- F. Manufacturer's Installation Instructions: Indicate special preparation of substrate, installation and attachment methods, and perimeter conditions requiring special attention.
- G. Warranty: Submit manufacturer warranty and ensure forms have been completed in Owner's name and registered with manufacturer.
- H. Maintenance Data: For users operation and maintenance of system including:
 - 1. Methods for maintaining system's materials and finishes.
 - 2. Precautions about cleaning materials and methods that could be detrimental to components, finishes, and performance.

1.4 QUALITY ASSURANCE

- A. Designer Qualifications:
- B. Fabricators Qualifications: Company specializing in performing the work of this section with minimum 5 years experience.
- C. Installer Qualifications: Company specializing in performing the work of this section with minimum 5 years experience.

1.5 DELIVERY, STORAGE, AND HANDLING

- A. As required by the manufacturer for a warrantable installation of the installed products to meet the Performance and Design Criteria.

1.6 WARRANTY

- A. Sealed Insulating Glass Units: Provide a ten (10) year warranty to include coverage for seal failure, interpane dusting or misting, including replacement of failed units.

PART 2 - PRODUCTS

2.1 DESCRIPTION

- A. Glass glazing and accessories installed as monolithic glazing, insulating glazing units within framing systems and support structures specified elsewhere.

**KOPACHUCK STATE PARK
DAY USE DEVELOPMENT**

2.2 PERFORMANCE AND DESIGN CRITERIA

- A. By horizontal (roller-hearth) process with roll-wave distortion parallel to bottom edge of glass as installed unless otherwise indicated.
- B. Roll Wave Maximum Distortion Tolerance: 0.003 inch target with 0.005 inch maximum peak to valley measurement.
- C. Bow and Warp Maximum Tolerance: 50 percent of the maximum allowed in ASTM C 1048.
- D. Thickness: As required for loads indicated
- E. Deflection no greater than 1/175 of the longest dimension or 1/2 inch whichever is less.

2.3 MATERIALS

- A. Float Glass:
 - 1. Performance Criteria:
 - a. By horizontal (roller-hearth) process with roll-wave distortion parallel to bottom edge of glass as installed unless otherwise indicated.
 - b. Roll Wave Maximum Distortion Tolerance: 0.003 inch target with 0.005 inch maximum peak to valley measurement.
 - c. Bow and Warp Maximum Tolerance: 50 percent of the maximum allowed in ASTM C 1048.
 - d. Tinted Types: Performance and features to match basis of design product.
 - 2. Annealed Type: ASTM C1036, Type I, transparent flat, Class 1 clear, Quality Q3 (glazing select).
 - 3. Heat-Strengthened in accordance with ASTM C1048.
- B. Fully Tempered in accordance with ASTM C1048.
 - 1. Safety Glazing: Comply with 16 CFR 1201 test requirements for Category II.
- C. Low-E Coated Vision Glass:
 - 1. Vision Glazing (South & East Exposure)- (Max U=.27, SHGC =.30, Shading Coefficient=.34, Visible Light= 71%): 1 inch unit PPG Solarban 72 Starphire, composed of ¼ inch Low E coating on # 2 surface outer light, ½ inch argon filled space, and ¼ inch clear float on inner lite. See drawings for window types indicating tempered locations.

**KOPACHUCK STATE PARK
DAY USE DEVELOPMENT**

- D. Insulating Glazing Units:
1. Fabricator:
 - a. Any of the manufacturers specified for float glass.
 - b. Any fabricator certified by glass manufacturer for type of glass, coating, and treatment involved and capable of providing specified performance, features and warranty.
 2. Sealed Insulating Glass Units:
 - a. Performance:
 - 1) Durability: Certified by an independent testing agency to comply with ASTM E2190.
 - 2) Edge Spacers: Material as required to meet performance criteria listed for assemblies.
 - a) Color: Black.
 - 3) Edge Seal: Glass to elastomer with supplementary silicone sealant.
 - a) Color: Black.
 - 4) Air Space: Hermetic air.
 - 5) U-Value: As required to meet performance criteria of complete assembly, not to exceed 0.24 Center of Glass.
- E. Insulated Glass Assembly with Integral Horizontal Blinds (at Welcome Center Building):
1. Based on products by BetweenGlassBlinds, LLC;4373 NW 124th Avenue, Coral Springs, FL 33065, 866-466-9525, email sales@betweenglassblinds.com , www.betweenglassblinds.com
 2. Provide glazing unit per requirements contained in Paragraph 2.3 (B) (C) and (D).
 3. Horizontal louver blinds:
 - a. Slats: 6010-T8 aluminum alloy, 5/8 inch wide x 0.008 inch thick.
 - b. Color: To be selected from manufacturer's full color range.
 - c. Operable by magnet, tilt only.

PART 3 - EXECUTION

3.1 EXAMINATION

- A. Verify existing conditions meet the manufacturer's requirements before starting work.

3.2 PREPARATION

- A. Prepare surfaces to receive work in accordance with manufacturer's instructions.

**KOPACHUCK STATE PARK
DAY USE DEVELOPMENT**

3.3 INSTALLATION

- A. General: Install all materials in accordance with manufacturer's instructions based on conditions present.

3.4 ADJUSTING

- A. Adjust and lubricate hardware for proper operation.

3.5 PROTECTION

- A. Protect installed work as required by the manufacturer to maintain product performance, design criteria and warranty.

END OF SECTION 088000

**KOPACHUCK STATE PARK
DAY USE DEVELOPMENT**

SECTION 089100 - LOUVERS

PART 1 GENERAL

1.1 SECTION INCLUDES

- A. Fixed louvers.

1.2 RELATED REQUIREMENTS

- A. 076200 - Sheet Metal Flashing and Trim.
- B. 079200 - Joint Sealers.
- C. Division 23: for louver performance requirements.

1.3 SUBMITTALS

- A. Qualification Data: For manufacturer.
- B. Product Data: Provide data describing design characteristics, maximum recommended air velocity, design free area, materials and finishes.
- C. Shop Drawings: Indicate louver layout plan and elevations, opening and clearance dimensions, tolerances; head, jamb and sill details; blade configuration, screens, blankout areas required, and frames.
- D. Sample: Submit two samples 4 inch x 6 inches in size illustrating finish and color of exterior and interior surfaces.
- E. Manufacturer's Installation Instructions: Indicate special preparation of substrate, installation and attachment methods, and perimeter conditions requiring special attention.
- F. Maintenance Data: For users operation and maintenance of system including:
 - 1. Methods for maintaining system's performance, materials and finishes.
 - 2. Precautions about cleaning materials and methods that could be detrimental to components, finishes, and performance.
 - 3. Recommendations on maintenance schedule.

**KOPACHUCK STATE PARK
DAY USE DEVELOPMENT**

1.4 QUALITY ASSURANCE

- A. Manufacturer Qualification: Company specializing in the manufacture of work specified in this section with minimum 5 years experience.

1.5 DELIVERY, STORAGE, AND HANDLING

- A. As required by the manufacturer for a warrantable installation of the installed products to meet the Performance and Design Criteria.

1.6 WARRANTY

- A. Manufacturer's Finish Warranty: Correct defective work within a 20 year period after Substantial Completion for degradation of panel finish, including color fading caused by exposure to weather.
 - 1. Panel Finish Criteria are listed AAMA 2605.

PART 2 - PRODUCTS

2.1 DESCRIPTION

- A. Factory fabricated and assembled architectural louvers including fixed, operable and acoustic types.

2.2 PERFORMANCE AND DESIGN CRITERIA

- A. AMCA Certified in accordance with AMCA 511.
- B. Wind Load Resistance: Design to resist positive and negative wind load of 25 psf without damage or permanent deformation.
- C. Intake Louvers: Design to allow maximum of 0.01 oz/sq ft water penetration at 850 feet per minute, when tested in accordance with AMCA 500-L.
- D. Drainable Blades: Continuous rain stop at front or rear of blade aligned with vertical gutter recessed into both jambs of frame.
- E. Screens: Provide insect screens at intake louvers and bird screens at exhaust louvers.

**KOPACHUCK STATE PARK
DAY USE DEVELOPMENT**

2.3 **FIXED LOUVERS**

A. Glazed in Fixed Louver:

1. Basis of Design Product: Model A4097G with glazing frame by Construction Specialties Inc. Comparable and substituted products will be judged based on the following performance criteria, features, warranty, and qualifications.
2. Performance Criteria:
 - a. Free Area: 50 percent, minimum.
 - b. Static Pressure Loss: 0.15 inch wg maximum per square foot of free area at velocity of 854 fpm, when tested in accordance with AMCA 500-L.
3. Features:
 - a. Glazing Frame for integration into aluminum framing systems with typical 1 inch glazing pocket.
 - b. Blades: Drainable.
 - c. Frame: 4 inches deep, channel profile; corner joints mitered and, with continuous recessed caulking channel each side.
 - d. Aluminum Thickness: Frame 12 gage, 0.0808 inch minimum; blades 12 gage, 0.0808 inch minimum.

B. Fixed Louver:

1. Basis of Design Product: Model ELF445DXH by Ruskin. Comparable and substituted products will be judged based on the following performance criteria, features, warranty, and qualifications.
2. Performance Criteria:
 - a. Free Area: 50 percent, minimum.
 - b. Static Pressure Loss: 0.15 inch wg maximum per square foot of free area at velocity of 900 fpm, when tested in accordance with AMCA 500-L.
3. Features:
 - a. Blades: Drainable.
 - b. Frame: 5 inches deep, channel profile; corner joints mitered and, with continuous recessed caulking channel each side.
 - c. Aluminum Thickness: Frame 12 gage, 0.0808 inch minimum; blades 12 gage, 0.0808 inch minimum.

2.4 **ACCESSORIES**

- A. All accessory materials are required by the manufacturer for warrantable installation of the installed products in a manner that meets the Performance and Design Criteria.
- B. Blank-Off Panels: Same material as louver, painted black on exterior side; provide where duct connected to louver is smaller than louver frame, sealing off louver area

**KOPACHUCK STATE PARK
DAY USE DEVELOPMENT**

outside duct.

- C. Bird Screen: Interwoven wire mesh of steel, 14 gage, 0.0641-inch diameter wire, 1/2 inch open weave, diagonal design.
- D. Fasteners and Anchors: Stainless steel.
- E. Flashings: Of same material as louver frame, formed to required shape, single length in one piece per location.
- F. Sealant: type, as specified in Section 079200 – Joint Sealers.

PART 3 - EXECUTION

3.1 EXAMINATION

- A. Verify existing conditions meet the manufacturer's requirements before starting work.

3.2 PREPARATION

- A. Prepare surfaces to receive work in accordance with manufacturer's instructions.

3.3 INSTALLATION

- A. General: Install all materials in accordance with manufacturer's instructions based on conditions present.
- B. Install perimeter sealant and backing rod in accordance with Section 079200 – Joint Sealers.
- C. Coordinate with installation of mechanical ductwork.
- D. Coordinate with installation of louver actuators.

3.4 PROTECTION

- A. Protect installed work as required by the manufacturer to maintain product performance, design criteria and warranty.

END OF SECTION 089100

**KOPACHUCK STATE PARK
DAY USE DEVELOPMENT**

SECTION 089516 - WALL VENTS

PART 1 - GENERAL

1.1 SUMMARY

- A. Standard size extruded aluminum wall vents with fixed louvers for installation in framed and concrete walls for crawl space ventilation at Day Use Building.

1.2 ACTION SUBMITTALS

- A. Product Data: For each type of product.
- B. Samples: Provide color sample.

1.3 INFORMATIONAL SUBMITTALS

- A. Research reports.
- B. Sample warranties.

1.4 WARRANTY

- A. Special Finish Warranty: Manufacturer agrees to repair or replace components on which finishes fail in materials or workmanship within specified warranty period.
 - 1. Warranty Period: 10 years from date of Substantial Completion.

PART 2 - PRODUCTS

2.1 WALL VENTS

- A. Extruded-Aluminum Wall Vents:
 - 1. Manufacturer: Sunvent Industries, a division of Syro Sales Corporation;
www.sunventindustries.com
 - 2. Model: "FL" Style extruded aluminum vents
 - 3. Materials:
 - a. Extruded Aluminum: 0.125inch minimum thickness extruded aluminum complying with ASTM B221, Alloy 6063, Temper T-5.
 - b. Sheet Aluminum: 0.040 inch minimum thickness complying with ASTM B209.

**KOPACHUCK STATE PARK
DAY USE DEVELOPMENT**

- c. Fasteners: Type, size, and spacing as recommended by vent manufacturer for project conditions.
- d. Sealant and Backer Rod: Type as recommended by vent manufacturer.
- e. Width: 15- 5/8"
- f. Height: 11-3/4"
- g. Depth: 1-1/2 inch.
- h. Free Area per vent: 0.400 SF
- i. Construction: Extruded aluminum framed vent with 1 inch front flange and overlapping horizontal louver blades fabricated from extruded aluminum sections.
- j. Louver Blades: Fixed, horizontal blades 1 inch deep at 1 inch centers. Blade shall be set at 45 degrees. Top of blade formed with storm drip.
- k. Frame:
 - 1) Material: Extruded aluminum.
 - 2) Exposed frame shall be 1 inch wide on all sides of vent.
 - 3) Bottom of vent shall have an integral water stop at back of vent frame.
- l. Insect Screen:
 - 1) Aluminum, 18x14 mesh screen set behind louvers in extruded stop on frame.
- m. Anodized Finish: Dark Bronze anodized coating complying with AAMA 606.1-MM10C22A44.

PART 3 - EXECUTION

3.1 INSTALLATION

A. General:

- 1. Do not install vents that are damaged or scratched. Replace damaged and scratched vents.
- 2. Install vents secure, level and plumb.
- 3. After installation is complete seal around perimeter flange of vent with sealant.

B. Framed construction and concrete foundation walls:

- 1. Install vents in accordance with manufacturer's installation instructions and approved shop drawings.

C. Exposed Fasteners:

- 1. Drill two holes, minimum, in front flange of vent, mechanically secure vents to wall substrate.

3.2 CLEANING AND PROTECTION

A. Remove excess sealant with mineral spirits or other solvent acceptable to sealant manufacturer.

B. Wash exposed surfaces with solution of mild detergent applied with soft cloth.

END OF SECTION 089516

**KOPACHUCK STATE PARK
DAY USE DEVELOPMENT**

SECTION 092116 - GYPSUM BOARD ASSEMBLIES

PART 1 GENERAL

1.1 SECTION INCLUDES

- A. Wood stud wall framing.
- B. Acoustic insulation.
- C. Cementitious backing board.
- D. Gypsum wallboard.
- E. Joint treatment and accessories.
- F. Textured finish system.

1.2 RELATED REQUIREMENTS

- A. Section 061000 - Rough Carpentry: Wood blocking product and execution requirements.
- B. Section 061000 - Rough Carpentry: Wood sheathing installed as backing.
- C. Section 072500 - Weather Barriers: Water-resistive barrier over sheathing.

1.3 REFERENCE STANDARDS

- A. ANSI A108.11 - American National Standard for Interior Installation of Cementitious Backer Units; 2010 (Revised).
- B. ANSI A118.9 - American National Standard Specifications for Test Methods and Specifications for Cementitious Backer Units; 1999 (Reaffirmed 2010).
- C. ASTM C475/C475M - Standard Specification for Joint Compound and Joint Tape for Finishing Gypsum Board; 2015.
- D. ASTM C514 - Standard Specification for Nails for the Application of Gypsum Board; 2004 (Reapproved 2014).

**KOPACHUCK STATE PARK
DAY USE DEVELOPMENT**

- E. ASTM C665 - Standard Specification for Mineral-Fiber Blanket Thermal Insulation for Light Frame Construction and Manufactured Housing; 2012.
 - F. ASTM C840 - Standard Specification for Application and Finishing of Gypsum Board; 2013.
 - G. ASTM C1002 - Standard Specification for Steel Self-Piercing Tapping Screws for Application of Gypsum Panel Products or Metal Plaster Bases to Wood Studs or Steel Studs; 2014.
 - H. ASTM C1047 - Standard Specification for Accessories for Gypsum Wallboard and Gypsum Veneer Base; 2014a.
 - I. ASTM C1325 - Specification for Non-Asbestos Fiber-Mat Reinforced Cementitious Backer Units; 2014.
 - J. ASTM C1396/C1396M - Standard Specification for Gypsum Board; 2014.
 - K. ASTM D3273 - Standard Test Method for Resistance to Growth of Mold on the Surface of Interior Coatings in an Environmental Chamber; 2012.
 - L. GA-216 - Application and Finishing of Gypsum Board; 2013.
- 1.4 SUBMITTALS
- A. See Section 013300 – Submittal Procedures, for submittal procedures.
 - B. Product Data: Provide data on metal framing, gypsum board, accessories, and joint finishing system.
 - C. Test Reports: For stud framing products that do not comply with ASTM C645 or ASTM C754, provide independent laboratory reports showing maximum stud heights at required spacings and deflections.
- 1.5 QUALITY ASSURANCE
- A. Installer Qualifications: Company specializing in performing gypsum board installation and finishing, with minimum 5 years of experience.
- PART 2 PRODUCTS
- 2.1 GYPSUM BOARD ASSEMBLIES
- A. Provide completed assemblies complying with ASTM C840 and GA-216.

**KOPACHUCK STATE PARK
DAY USE DEVELOPMENT**

2.2 BOARD MATERIALS

- A. Gypsum Wallboard: Paper-faced gypsum panels as defined in ASTM C1396/C1396M; sizes to minimize joints in place; ends square cut.
 - 1. Application: Use for vertical surfaces and ceilings, unless otherwise indicated.
 - 2. Mold Resistance: Score of 10, when tested in accordance with ASTM D3273.

- B. Mold resistant board is required at all locations.
 - 1. At Assemblies Indicated with Fire-Rating: Use type required by indicated tested assembly; if no tested assembly is indicated, use Type X board, UL or WH listed.
 - 2. Thickness:
 - a. Vertical Surfaces: 5/8 inch.
 - b. Ceilings: 5/8 inch.

- C. Backing Board for Wet Areas:
 - 1. Application: Surfaces behind tile in wet areas including tub and shower surrounds.
 - 2. ANSI Cement-Based Board: Non-gypsum-based; aggregated Portland cement panels with glass fiber mesh embedded in front and back surfaces complying with ANSI A118.9 or with glass fiber mesh embedded in front and back surfaces complying with ANSIA118.9 or ASTM C1325.
 - 3. Thickness: 1/2 inch.

2.3 ACCESSORIES

- A. Acoustic Insulation: 1; preformed glass fiber, friction fit type, unfaced. Thickness: 3-1/2 inch.

- B. Acoustic Sealant: Acrylic emulsion latex or water-based elastomeric sealant; do not use solvent-based non-curing butyl sealant.

- C. Finishing Accessories: ASTM C1047, galvanized steel or rolled zinc, unless noted otherwise.
 - 1. Types: As detailed or required for finished appearance.

- D. Joint Materials: ASTM C475/C475M and as recommended by gypsum board manufacturer for project conditions.

- E. Textured Finish Materials: Latex-based compound; plain.

- F. Nails for Attachment to Wood Members: ASTM C514.

**KOPACHUCK STATE PARK
DAY USE DEVELOPMENT**

PART 3 EXECUTION

3.1 EXAMINATION

- A. Verify that project conditions are appropriate for work of this section to commence.

3.2 FRAMING INSTALLATION

- A. Suspended Ceilings and Soffits: Space framing and furring members as permitted by standard.
 - 1. Level ceiling system to a tolerance of 1/1200.
 - 2. Laterally brace entire suspension system.
- B. Openings: Reinforce openings as required for weight of doors or operable panels, using not less than double studs at jambs.
- C. Blocking: Install wood blocking for support of:
 - 1. Framed openings.
 - 2. Wall mounted cabinets.
 - 3. Plumbing fixtures.
 - 4. Toilet accessories.
 - 5. Wall mounted door hardware.

3.3 ACOUSTIC ACCESSORIES INSTALLATION

- A. Acoustic Insulation: Place tightly within spaces, around cut openings, behind and around electrical and mechanical items within partitions, and tight to items passing through partitions.
- B. Acoustic Sealant: Install in accordance with manufacturer's instructions.

3.4 BOARD INSTALLATION

- A. Comply with ASTM C840, GA-216, and manufacturer's instructions. Install to minimize butt end joints, especially in highly visible locations.
- B. Cementitious Backing Board: Install over steel framing members where indicated, in accordance with ANSI A108.11 and manufacturer's instructions.
- C. Installation on Wood Framing: For rated assemblies, comply with requirements of listing authority. For non-rated assemblies, install as follows:
 - 1. Single-Layer Applications: Screw attachment.

**KOPACHUCK STATE PARK
DAY USE DEVELOPMENT**

3.5 3.5 INSTALLATION OF TRIM AND ACCESSORIES

- A. Control Joints: Place control joints consistent with lines of building spaces and as indicated.
- B. Corner Beads: Install at external corners, using longest practical lengths.

3.6 JOINT TREATMENT

- A. Finish gypsum board in accordance with levels defined in ASTM C840, as follows:
 - 1. Level 4: Walls and ceilings to receive paint finish or wall coverings, unless otherwise indicated.
 - 2. Level 3: Walls to receive textured wall finish.
 - 3. Level 1: Fire rated wall areas above finished ceilings, whether or not accessible in the completed construction.
- B. Tape, fill, and sand exposed joints, edges, and corners to produce smooth surface ready to receive finishes.
 - 1. Feather coats of joint compound so that camber is maximum 1/32 inch.
- C. Fill and finish joints and corners of cementitious backing board as recommended by manufacturer.

3.7 TEXTURE FINISH

- A. Apply finish texture coating by means of spraying apparatus in accordance with
- B. Manufacturer's instructions and to match approved sample.

3.8 TOLERANCES

- A. Maximum Variation of Finished Gypsum Board Surface from True Flatness: 1/8 inch in 10 feet in any direction.

END OF SECTION 092116

**KOPACHUCK STATE PARK
DAY USE DEVELOPMENT**

SECTION 093013 - CERAMIC TILING

PART 1 - GENERAL

1.1 SUMMARY

A. Section Includes:

1. Ceramic mosaic tile for floor application.
2. Glazed wall tile.
3. Tile backing panels.
4. Waterproofing and crack prevention membrane.
5. Ceramic accessories and trim.

1.2 ACTION SUBMITTALS

A. Product Data: For each type of product.

B. Samples:

1. Each type and composition of tile and for each color and finish required.

1.3 INFORMATIONAL SUBMITTALS

A. Qualification Data: For Installer.

1.4 MAINTENANCE MATERIAL SUBMITTALS

A. Furnish extra materials that match and are from same production runs as products installed and that are packaged with protective covering for storage and identified with labels describing contents.

1. Tile and Trim Units: Furnish quantity of full-size units equal to 10 percent of amount installed for each type, composition, color, pattern, and size indicated.

1.5 QUALITY ASSURANCE

A. Installer Qualifications:

1. Installer employs at least one installer for Project that has completed the Advanced Certification for Tile Installers (ACT) certification.

**KOPACHUCK STATE PARK
DAY USE DEVELOPMENT**

PART 2 - PRODUCTS

2.1 PRODUCTS, GENERAL

- A. ANSI A108/A118/A136.1-American National Standard Specifications for the Installation of Ceramic Tile-Version 2014.
- B. ASTM F1869-Standard Test Method for Measuring Moisture Vapor Emission Rate of Concrete Subfloor Using Anhydrous Calcium Chloride; 2011.
- C. TCNA (HB)-Handbook for Ceramic, Glass, and Stone Tile Installation-Version 2015.

2.2 TILE PRODUCTS

- A. Tile manufacturers:
 - 1. American Olean Corporation: www.americanolean.com
 - 2. Dal-Tile: www.daltile.com
 - 3. Substitutions: See Section 016000-Product Requirements.
- B. Ceramic Mosaic Tile: ANSI A137.1, and as follows.
 - 1. Size and Shape: 2 inch square.
 - 2. Edges: Square.
 - 3. Surface Finish: Unglazed.
 - 4. Colors: To be selected from manufacturer's standard range, light hue, single color.
 - 5. Trim Units: Matching bead and cove shapes in sizes coordinated with field tile.
- C. Glazed Wall: ANSI A137.1, and as follows:
 - 1. Size and Shape: 4-1/4" square.
 - 2. Edges: Square.
 - 3. Surface Finish: High gloss.
 - 4. Colors: To be selected from manufacturer's standard range, light hue for field color.
 - 5. Pattern: Deep colored accent tiles installed at approximately 5'-0" high.
 - 6. Trim Units: Matching bead, bullnose, surface bullnose, cove, base and other required shapes in sizes coordinated with field tile.

2.3 TRIM

- A. Ceramic Accessories: Glazed finish, same color and finish as adjacent field tile; same manufacturer as tile.
- B. Ceramic Trim: Matching bullnose, cove base, and cove ceramic shapes in sizes coordinated with field tile.

**KOPACHUCK STATE PARK
DAY USE DEVELOPMENT**

1. Applications:
 - a. Open Edges: Bullnose
 - b. Inside Corners: Coved.
 - c. Floor to Wall Joints: Cove base.
2. Manufacturers: Same as for tile.

2.4 SETTING MATERIALS

- A. Provide setting materials made by the same manufacturer as grout.
- B. Latex-Portland Cement Mortar Bond Coat: ANSI A118.4 or better.
- C. Per TCNA Installation Methods:
 1. Interior Floors over Wood: F180-14
 2. Interior Floors over Concrete: F113-14
 3. Interior Walls: W244C-14

2.5 WATERPROOFING AND CRACK PROTECTION MEMBRANE

- A. Waterproofing and Anti-Fracture Membrane: Provide at Day Use Building toilet rooms located over wood substrate.
 1. Custom Building Products; “RedGuard” Waterproofing and Crack Protection Membrane; Liquid Applied Membrane or approved equal.

2.6 SETTING MATERIALS

- A. Modified Dry-Set Mortar (Thinset): ANSI A118.4 or better.
 1. Custom Building Products; Polymer Modified Thin Set Mortar or approved equal.
 2. For wall applications, provide nonsagging mortar.

2.7 GROUT MATERIALS

- A. Polymer Modified Grout: ANSI A118.7 polymer modified cement grout.
 1. Custom Building Products; Prism SureColor Grout or approved equal.
 2. Rated for scratch/abrasion sensitive tile surfaces.
 3. Use sanded grout for joints 1/8 inch and larger; use unsanded grout for joints less than 1/8 inch wide.

2.8 ACCESSORY MATERIALS

- A. Metal Edge Strips: Schluter-RENO-U or approved equal.

**KOPACHUCK STATE PARK
DAY USE DEVELOPMENT**

1. Description: Profile with sloped exposed surface, 5/32" tall leading edge, integrated trapezoid perforated anchoring leg and integrated grout joint spacer; EB-brushed stainless steel. Height as required.
- B. Tile Backing Panels: Cementitious backer units, ANSI A118.9 or ASTM C 1325.
 1. USG "Durock" cement board or approved equal
 2. Thickness: ½ inch.

PART 3 - EXECUTION

3.1 EXAMINATION

- A. Examine substrates, areas, and conditions where tile will be installed, with Installer present, for compliance with requirements for installation tolerances and other conditions affecting performance of the Work.
 1. Verify that substrates for setting tile are firm; dry; clean; free of coatings that are incompatible with tile-setting materials, including curing compounds and other substances that contain soap, wax, oil, or silicone; and comply with flatness tolerances required by ANSI A108.01 for installations indicated.
- B. Proceed with installation only after unsatisfactory conditions have been corrected.

3.2 PREPARATION

- A. Fill cracks, holes, and depressions in concrete substrates for tile floors installed with thinset mortar with trowelable leveling and patching compound specifically recommended by tile-setting material manufacturer.
- B. Where indicated, the lightweight cement, "GypCrete" substrate to receive waterproof and crack prevention membrane must obtain a minimum of 2000 psi compressive strength at the recommended cure time. Prime all surfaces to receive "RedGuard" with properly applied primer coat of "RedGuard" consisting of 1 part "RedGuard", diluted with 4 parts clean, cool water. In a clean pail, mix at low speed to obtain a lump-free solution. The primer can be brushed, rolled, or sprayed to achieve an even coat. Apply the primer coat to the floor at rate of 300 ft/gallon of reduced material. When dry, apply at least one full coat of "RedGuard" to primed area by applying a reinforced mortar bed that complies with ANSI A108.1A. Slope toilet room floor maximum 2% slope to floor drain to meet ADA standards.
- C. Comply with TCNA's "Handbook for Ceramic, Glass, and Stone Tile Installation" for TCNA installation methods specified in tile installation schedules. Comply with parts of the ANSI A108 series "Specifications for Installation of Ceramic Tile" that are referenced in TCNA installation methods, specified in tile installation schedules, and apply to types of setting and grouting materials used.
- D. Metal Edge Strips: Install where exposed edge of tile flooring meets below top of tile.

**KOPACHUCK STATE PARK
DAY USE DEVELOPMENT**

- E. Install tile backing panels and treat joints according to ANSI A108.11 and manufacturer's written instructions for type of application indicated. Use modified dry-set mortar for bonding material unless otherwise directed in manufacturer's written instructions.
- F. Install waterproofing and crack prevention membrane to comply with ANSI A108.13 and manufacturer's written instructions to produce membrane of uniform thickness that is bonded securely to substrate.

3.3 INSTALLATION

- A. General: Install all materials in accordance with manufacturer's instructions based on conditions present.
- B. Extend tile work under fixtures to form complete covering without interruptions. Terminate work neatly at obstructions, edges, and corners.
- C. Ground Tile - When partial tiles must be used on exposed edges:
 - 1. Grind the edges of cut unglazed thru-body tile to mimic the factory edge and place the cut edge in.
 - 2. If the cut edge must face out, grind with fine enough grit to match the finish texture of the tile as close as possible.
- D. Lay tile to pattern indicated.
 - 1. Do not interrupt tile pattern through openings.
 - 2. Align floor, base, wall, and trim joints where sizes permit.
 - 3. Lay out tilework and center tile fields in both directions in each space or each wall area. Adjust to minimize tile cutting.
- E. Place tile joints uniform in width, subject to variance in tolerance allowed in tile size. Make grout joints without voids, cracks, excess mortar or excess grout, or too little grout.
 - 1. Glazed Wall and Floor Tile: 1/8 inch.
- F. Sound tile after setting. Replace hollow sounding units.
- G. Prior to grouting, allow installation to completely cure; minimum of 48 hours.
- H. Grout tile joints.

END OF SECTION 093013

**KOPACHUCK STATE PARK
DAY USE DEVELOPMENT**

SECTION 095100 – SUSPENDED ACOUSTICAL CEILINGS

PART 1 - GENERAL

1.1 SECTION INCLUDES

- A. Suspended metal grid ceiling system.
- B. Acoustical units.

1.2 REFERENCE STANDARDS

- A. ASTM C635/C635M - Standard Specification for the Manufacture, Performance, and Testing of Metal Suspension Systems for Acoustical Tile and Lay-in Panel Ceilings; 2013a.
- B. ASTM E1264 - Standard Classification for Acoustical Ceiling Products; 2014.

1.3 SUBMITTALS

- A. See Section 013300 - Submittal Procedures, for Administrative Requirements.
- B. Shop Drawings: Indicate grid layout and related dimensioning.
- C. Product Data: Provide data on suspension system components.
- D. Manufacturer's Installation Instructions: Indicate special procedures and perimeter conditions requiring special attention.

1.4 QUALITY ASSURANCE

- A. Suspension System Manufacturer Qualifications: Company specializing in manufacturing the products specified in this section with minimum three years documented experience.
- B. Acoustical Unit Manufacturer Qualifications: Company specializing in manufacturing the products specified in this section with minimum three years documented experience.
- C. Fire Performance Characteristics: Identify acoustical ceiling components with appropriate markings of applicable testing and inspecting organization.
 - 1. Surface Burning Characteristics: As follows, tested per ASTM E 84 and complying with ASTM E 1264 for Class A products.

**KOPACHUCK STATE PARK
DAY USE DEVELOPMENT**

- a. Flame Spread: 25 or less
- b. Smoke Developed: 50 or less

1.5 WARRANTY

- A. See Section 017700 - Closeout Procedures, for additional warranty requirements.
- B. Acoustical Panel: Submit a written warranty executed by the manufacturer, agreeing to repair or replace acoustical panels that fail within the warranty period. Failures include, but are not limited to:
 - 1. Acoustical Panels: Sagging and warping
 - 2. Grid System: Rusting and manufacturer's defects.
- C. Warranty Period:
 - 1. Acoustical panels: One (1) year from date of substantial completion.
 - 2. Grid: Ten years from date of substantial completion.

1.6 FIELD CONDITIONS

- A. Maintain uniform temperature of minimum 60 degrees F, and maximum humidity of 40 percent prior to, during, and after acoustical unit installation.

PART 2 PRODUCTS

2.1 MANUFACTURERS

- A. Acoustical Panels:
 - 1. Armstrong World Industries, Inc; Cortega Tile and Lay-in, 2776: www.armstrong.com.
 - 2. Substitutions: See Section 016000 - Product Requirements.
- B. Suspension Systems:
 - 1. Same as for acoustical units.
 - 2. Substitutions: See Section 016000 - Product Requirements.

2.2 ACOUSTICAL UNITS

- A. Acoustical Units - General: ASTM E1264, Class A.
- B. Acoustical Panels: Painted mineral fiber, ASTM E1264 Type III, with the following characteristics:
 - 1. Size: 24 by 48 inches.
 - 2. Thickness: 5/8 inches.

**KOPACHUCK STATE PARK
DAY USE DEVELOPMENT**

3. Composition: Wet felted.
4. NRC: 0.55, determined as specified in ASTM E 1264.
5. Edge: Reveal edge.
6. Form: 2 (ASTM E 1264)
7. Surface Pattern: C D (ASTM E 1264).
8. Suspension System: Exposed grid.

2.3 SUSPENSION SYSTEM(S)

A. Manufacturers:

1. Same as for acoustical units.

B. Suspension Systems - General: Complying with ASTM C635/C635M; die cut and interlocking components, with stabilizer bars, clips, splices, perimeter moldings, and hold down clips as required. Comply with ASCE 7-10, Appendix 11A for anchorage and seismic bracing.

C. Exposed Steel Suspension System: Formed steel, commercial quality cold rolled; heavy-duty.

1. Profile: Tee; 15/16 inch wide face.
2. Finish: White painted.

2.4 ACCESSORIES

A. Support Channels and Hangers: Galvanized steel; size and type to suit application, seismic requirements, and ceiling system flatness requirement specified.

B. Perimeter Moldings: Same material and finish as grid.

1. At Exposed Grid: Provide L-shaped molding for mounting at same elevation as face of grid.

C. Gasket for Perimeter Moldings: Closed cell rubber sponge tape.

D. Touch-up Paint: Type and color to match acoustical and grid units.

PART 3 EXECUTION

3.1 EXAMINATION

- A. Verify existing conditions before starting work.
- B. Verify that layout of hangers will not interfere with other work.

**KOPACHUCK STATE PARK
DAY USE DEVELOPMENT**

3.2 INSTALLATION - SUSPENSION SYSTEM

- A. Rigidly secure system, including integral mechanical and electrical components, for maximum deflection of 1:360.
- B. Lay out system to a balanced grid design with edge units no less than 50 percent of acoustical unit size.
- C. Install after major above-ceiling work is complete. Coordinate the location of hangers with other work.
- D. Hang suspension system independent of walls, columns, ducts, pipes and conduit. Where carrying members are spliced, avoid visible displacement of face plane of adjacent members.
- E. Where ducts or other equipment prevent the regular spacing of hangers, reinforce the nearest affected hangers and related carrying channels to span the extra distance.
- F. Do not support components on main runners or cross runners if weight causes total deadload to exceed deflection capability.
- G. Support fixture loads using supplementary hangers located within 6 inches of each corner, or support components independently.
- H. Do not eccentrically load system or induce rotation of runners.
- I. Perimeter Molding: Install at intersection of ceiling and vertical surfaces and at junctions with other interruptions.
 - 1. Use longest practical lengths.
 - 2. Overlap and rivet corners.

3.3 INSTALLATION - ACOUSTICAL UNITS

- A. Install acoustical units in accordance with manufacturer's instructions.
- B. Fit acoustical units in place, free from damaged edges or other defects detrimental to appearance and function.
- C. Fit border trim neatly against abutting surfaces.
- D. Install units after above-ceiling work is complete.
- E. Install acoustical units level, in uniform plane, and free from twist, warp, and dents.

**KOPACHUCK STATE PARK
DAY USE DEVELOPMENT**

F. Cutting Acoustical Units:

1. Cut to fit irregular grid and perimeter edge trim.
2. Make field cut edges of same profile as factory edges.

G. Lay acoustical insulation for a distance of 48 inches either side of acoustical partitions as indicated.

3.4 TOLERANCES

A. Maximum Variation from Flat and Level Surface: 1/8 inch in 10 feet.

B. Maximum Variation from Plumb of Grid Members Caused by Eccentric Loads: 2 degrees.

END OF SECTION 095100

**KOPACHUCK STATE PARK
DAY USE DEVELOPMENT**

SECTION 095440 – MANUFACTURED CEILING PLANKS

PART 1 - GENERAL

1.1 SUMMARY

- A. Section includes manufactured ceiling planks.

1.2 ACTION SUBMITTALS

- A. Product Data: For each type of product.
- B. Samples: For each exposed product and for each color and texture specified.

PART 2 - PRODUCTS

2.1 MANUFACTURED CEILING PLANKS

- A. Manufactured Ceiling Planks:
 - 1. 5 inch x 84 inch planks, constructed with MDF (medium density fiberboard).
 - 2. Prefinished.
 - 3. Beveled tongue and groove edge.
 - 4. Manufacturer: Armstrong Ceilings or approved equal.
 - 5. Product: WoodHaven New Apple Wood Look Ceiling.
 - 6. Mounting: Armstrongs’s “Easy Up” tracks and clips installation system.

PART 3 - EXECUTION

3.1 INSTALLATION

- A. Install planks in locations indicated.
- B. Comply with manufacturer's written instructions for installation of planks using type of mounting devices indicated. Mount panels securely to supporting substrate.
- C. Clean planks on completion of installation to remove dust and other foreign materials according to manufacturer's written instructions.

END OF SECTION 095440

**KOPACHUCK STATE PARK
DAY USE DEVELOPMENT**

SECTION 096500 – RESILIENT FLOORING

PART 1 - GENERAL

1.1 SECTION INCLUDES

- A. Resilient tile flooring and accessories
- B. Resilient base.

1.2 RELATED REQUIREMENTS

- A. Section 033000 - Cast-in-Place Concrete: Restrictions on curing compounds for concrete slabs and floors.
- B. Section 033000 - Cast-In-Place Concrete

1.3 REFERENCE STANDARDS

- A. ASTM E648 - Standard Test Method for Critical Radiant Flux of Floor-Covering Systems Using a Radiant Heat Energy Source; 2014c.
- B. ASTM F1066 - Standard Specification for Vinyl Composition Floor Tile; 2004 (Reapproved 2014)e1.
- C. ASTM F1861 - Standard Specification for Resilient Wall Base; 2008 (Reapproved 2012)e1. D. ASTM F2034 - Standard Specification for Sheet Linoleum Floor Covering; 2008 (Reapproved 2013).
- D. ASTM F2195 - Standard Specification for Linoleum Floor Tile; 2013.
- E. NFPA 253 - Standard Method of Test for Critical Radiant Flux of Floor Covering Systems Using a Radiant Heat Energy Source; National Fire Protection Association; 2015.

1.4 SUBMITTALS

- A. See Section 013300 - Submittal Procedures.
- B. Product Data: Provide data on specified products, describing physical and performance characteristics; including sizes, patterns and colors available; and installation instructions.

**KOPACHUCK STATE PARK
DAY USE DEVELOPMENT**

- C. Shop Drawings: Indicate seaming plan.
- D. Selection Samples: Submit manufacturer's complete set of color samples for Architect's Initial selection.
- E. Verification Samples: Submit two samples, 12 by 12 inch in size illustrating color and pattern for each resilient flooring product specified.
- F. Maintenance Data: Include maintenance procedures, recommended maintenance materials, and suggested schedule for cleaning, stripping, and re-waxing.

1.5 QUALITY ASSURANCE

- A. Manufacturer: Provide resilient flooring manufactured by a firm with a minimum of 10 years experience in the fabrication of resilient flooring of types equivalent to those specified.
- B. Installers Qualifications: Installer experienced (minimum of 2 years) to perform work of this section who has specialized in the installation of work similar to that required for this project and who is acceptable to the product manufacturer.
- C. Materials: For each type of material required for the work of this Section, provide primary materials which are the products of one manufacturer. Provide secondary materials which are acceptable to the manufacturer of the primary materials. Comply with applicable regulations regarding VOC (volatile organic compound) content of adhesives.

1.6 DELIVERY, STORAGE, AND HANDLING

- A. Deliver materials in labeled packages. Store and handle in strict compliance with manufacturer's recommendations. Protect from damage due to weather, excessive temperatures, and construction operations.
- B. Deliver materials sufficiently in advance of installation to condition materials to room temperature prior to installation.

1.7 FIELD CONDITIONS

- A. Maintain a temperature of 68 degrees F (20 degrees C) plus or minus 5 degrees F (3 degrees C) in spaces to receive resilient flooring. Specified temperature shall be maintained at least 48 hours before, during, and 48 hours after installation.
- B. Furnish full size units equal to 2 percent of quantity of resilient flooring installed as extra materials. Properly label and package extra materials. Deliver to Owner's designated storage

**KOPACHUCK STATE PARK
DAY USE DEVELOPMENT**

area.

PART 2 PRODUCTS

2.1 SHEET FLOORING

- A. Linoleum Sheet Flooring: Homogeneous wear layer bonded to backing, with color and pattern through wear layer thickness. Sheet flooring for installations in rooms with cove base (bathrooms, etc.) only.
 - 1. Minimum Requirements: Comply with ASTM F2034, Type corresponding to type specified.
 - 2. Backing: Jute fabric.
 - 3. Wear Layer Thickness: 0.10 inch, minimum, excluding backing.
 - 4. Pattern: Solid color.
 - 5. Color: To be selected by Architect from manufacturer's full range.
 - 6. Seams: Heat welded.
 - 7. Manufacturers:
 - a. Forbo Flooring Systems; Marmoleum Real: www.forbo.com.
 - b. Substitutions: See Section 016000 - Product Requirements.
- B. Welding Rod: Solid bead in material compatible with flooring, produced by flooring manufacturer for heat welding seams, and in color matching field color.

2.2 RESILIENT BASE

- A. Resilient Base: ASTM F1861, Type TS rubber, vulcanized thermoset; top set Style B, Cove.
 - 1. Height: 4 inch.
 - 2. Thickness: 0.125 inch thick.
 - 3. Length: Roll.
 - 4. Color: Color as selected from manufacturer's standards.

2.3 ACCESSORIES

- A. Primers and Adhesives: Waterproof; types recommended by flooring manufacturer.
- B. Moldings, Transition and Edge Strips: Rubber.
 - 1. Colors: To be selected by Architect from manufacturer's standard range of colors.
- C. Filler for Coved Base: Plastic.
- D. Sealer and Wax: Types recommended by flooring manufacturer.

PART 3 EXECUTION

**KOPACHUCK STATE PARK
DAY USE DEVELOPMENT**

3.1 EXAMINATION

- A. Verify that surfaces are flat to tolerances acceptable to flooring manufacturer, free of cracks that might telegraph through flooring, clean, dry, and free of curing compounds, surface hardeners, and other chemicals that might interfere with bonding of flooring to substrate.
- B. Cementitious Sub-floor Surfaces: Verify that substrates are dry enough and ready for resilient flooring installation by testing for moisture and pH.
 - 1. Obtain instructions if test results are not within limits recommended by resilient flooring manufacturer and adhesive materials manufacturer.
- C. Verify that concrete sub-floor surfaces are ready for resilient flooring installation by testing for moisture emission rate and alkalinity; obtain instructions if test results are not within limits recommended by resilient flooring manufacturer and adhesive materials manufacturer.
- D. Verify that required floor-mounted utilities are in correct location.

3.2 PREPARATION

- A. Remove sub-floor ridges and bumps. Fill minor low spots, cracks, joints, holes, and other defects with sub-floor filler to achieve smooth, flat, hard surface.
- B. Prohibit traffic until filler is fully cured.
- C. Clean substrate.
- D. Apply primer as required to prevent "bleed-through" or interference with adhesion by substances that cannot be removed.

3.3 INSTALLATION

- A. Starting installation constitutes acceptance of sub-floor conditions.
- B. Install in accordance with manufacturer's written instructions.
- C. Spread only enough adhesive to permit installation of materials before initial set.
- D. Fit joints and butt seams tightly.
- E. Set flooring in place, press with heavy roller to attain full adhesion.
- F. Where type of floor finish, pattern, or color are different on opposite sides of door, terminate

**KOPACHUCK STATE PARK
DAY USE DEVELOPMENT**

flooring under centerline of door.

- G. Install edge strips at unprotected or exposed edges, where flooring terminates, and where indicated.
- H. Scribe flooring to walls, columns, cabinets, floor outlets, and other appurtenances to produce tight joints.

3.4 SHEET FLOORING

- A. Lay flooring with joints and seams parallel to longer room dimensions, to produce minimum number of seams. Lay out seams to avoid widths less than 1/3 of roll width; match patterns carefully at seams.
- B. Seal seams by heat welding where indicated.
- C. Double cut sheet at seams.
- D. Lay flooring with tightly butted seams, without any seam sealer unless otherwise indicated.
- E. Double cut sheet; provide heat welded seams.
- F. Coved Base: Install coved base where indicated on drawings, using coved base filler as backing at floor to wall junction. Extend sheet flooring vertically to 4" above floor surface, and cover top edge with metal cap strip.

3.5 RESILIENT BASE

- A. Install per manufacturer directions.
- B. Fit joints tightly and make vertical. Maintain minimum dimension of 18 inches between joints.
- C. Install base on solid backing. Bond tightly to wall and floor surfaces.
- D. Scribe and fit to door frames and other interruptions.
- E. Adhere over entire surface. Fit accurately and securely.

3.6 CLEANING

- A. Remove excess adhesive from floor, base, and wall surfaces without damage.
- B. Clean and seal VCT flooring in accordance with manufacturer's instructions.

**KOPACHUCK STATE PARK
DAY USE DEVELOPMENT**

C. Clean linoleum flooring in accordance with manufacturer's instructions.

3.7 PROTECTION

A. Prohibit traffic on resilient flooring for 48 hours after installation.

END OF SECTION 096500

**KOPACHUCK STATE PARK
DAY USE DEVELOPMENT**

SECTION 096519 - RESILIENT TILE FLOORING

PART 1 - GENERAL

1.1 SUMMARY

A. Section Includes:

1. Resilient tile flooring and accessories.
2. Moisture barrier membrane.
3. Primer/sealer over gypsum based underlayment at Day Use Building.

1.2 ACTION SUBMITTALS

- A. Product Data: For each type of product.
- B. Samples: For each exposed product and for each color and pattern specified.

1.3 CLOSEOUT SUBMITTALS

- A. Maintenance data.

1.4 QUALITY ASSURANCE

- A. Installer Qualifications: An entity that employs installers and supervisors who are competent in techniques required by manufacturer for floor tile installation.

1.5 EXTRA MATERIAL

- A. Deliver to Owner extra material from same production run as products installed. Furnished flooring units equal to 2 percent of amount installed.

PART 2 - PRODUCTS

2.1 RESILIENT TILE FLOORING

- A. Resilient Tile Flooring: Korlock Van Gogh Rigid Core Planks by Kardean Designflooring, www.kardean.com.
- B. Dimensions: 48 inches by 7 inches.
 1. Wear Layer Thickness: 20 mil
 2. Tile Thickness: 0.18 inches

**KOPACHUCK STATE PARK
DAY USE DEVELOPMENT**

3. Edge: Micro bevel.
4. Compliance: ASTM F 3261
5. Classification: ASTM F 1700, Class 3, Type B
6. Slip Resistance: ASTM D 2047, Pass (Dry 0.89)
7. Reaction to Fire: ASTM E 648-06, Class 1
8. Staining Resistance: ASTM F 925, Pass.
9. Light Fastness: ASTM F 1515, not less than 8.
10. Abrasion Resistance: ASTM D 4060, 20,000 cycles.
11. Dimensional Stability: ISO 23,000, Pass.
12. Acoustic Impact Noise Reduction: ASTM E 492-09, IIC69
13. Indentation, Residual: ASTM F 1914, Pass.
14. Item Number and Name: To be determined.

2.2 MOISTURE BARRIER MEMBRANE

A. Moisture Barrier Membrane:

1. KOVARA 95 as manufactured by Traxx Corporation.
 - a. Material: Three layer composite construction of a HDPE bottom layer, glass mat middle layer, and gray mineral top layer.
 - b. Thickness: 0.024 inches.
 - c. Resilient to heavy rolling loads.
 - d. No VOC content.
 - e. Does not support mold or mildew growth.
 - f. Provides resistance to 95 percent relative humidity.
 - g. Tapes: As recommended by Manufacturer.

PART 3 - EXECUTION

3.1 EXAMINATION

- A. Inspect floor to be installed immediately upon arrival at job site. Perform moisture test.
- B. Using Portland based cementitious base leveler or patch fill and cover all seams, nail heads, voids, cracks, and expansion joints. Achieve smooth, even, firmly attached substrate for best finish results. Properly prepare gypsum based underlayment at Day Use Building as follows:
- C. Encapsulate gypsum based underlayment with a premium latex primer/sealer recommended by gypsum manufacturer.
- D. Concrete Substrates: The Contractor shall verify to the Owner and installer a minimum of 30 days prior to the scheduled resilient flooring installation the following substrate conditions. All substrate testing shall be documented and submitted to the Architect and Owner before commencement of the flooring installation.
 1. Verify that substrates are dry, free of debris, and all surfaces have properly cured.

**KOPACHUCK STATE PARK
DAY USE DEVELOPMENT**

2. Remove substrate coatings and other substances that are incompatible with adhesives and that contain soap, wax, oil, or silicone, using mechanical methods recommended by manufacturer. Do not use solvents.
3. Alkalinity and Adhesion Testing: Perform tests recommended by manufacturer. Proceed with installation only after substrates pass testing.
4. Moisture Testing: perform ASTM 1869 Calcium Chloride or ASTM 2170 In-Situ RH test and record results. Choose proper adhesive or moisture migration systems to meet manufacturer's specifications for moisture content. Proceed with installation only after substrates meet specifications.

E. Immediately before installation, sweep and vacuum clean substrates to be covered by resilient floor tile.

3.2 INSTALLING RESILIENT TILES AND PLANKS

A. General:

1. Permanent HVAC system shall be turned on and set to a minimum of 65 degrees F for a minimum of 48 hours prior to, during and 48 hours after installation.
2. All products shall be allowed to acclimate at least 24 hours before installation. This means product shall be placed in the same room as the install that is taking place and removed from its factory packaging.
3. Material shall be visually inspected prior to installation.
4. Install in accordance with manufacturer's installation instructions.

B. Layout and Installation:

1. Position planks so the end seams are no closer than the width of the plank being installed. Maintain this approach to staggering the planks throughout the entire installation while keeping a random appearance.
2. Center planks in rooms so borders are not less than half plank when possible.
3. Cut edges shall be installed against the wall.
4. Install using plank installation techniques recommended by manufacturer.
5. Additional requirements:
 - a. Comply with manufacturer's instruction sheets included in material packaging.
 - b. Install as "Floating Floor" assembly only. Use of adhesives is not recommended.
 - c. Install with a ¼ inch expansion at all walls and other vertical abutments.

3.3 CLEANING

A. Prior to installation of permanent fixtures or furniture, remove all dirt, and debris and clean floor.

3.4 MAINTENANCE

A. Comply with manufacturer's instructions for proper cleaning and maintenance of the products.

END OF SECTION 096519

**KOPACHUCK STATE PARK
DAY USE DEVELOPMENT**

SECTION 097733 – GLASS FIBER REINFORCED PLASTIC PANELS

PART 1 - GENERAL

1.1 SECTION INCLUDES

- A. Glass fiber reinforced plastic panels.
- B. Trim.

1.2 REFERENCE STANDARDS

- A. 9 CFR 416.2 - Regulatory Requirements Under the Federal Meat Inspection Act and the Poultry Products Inspection Act, Part 416-Sanitation; current edition.
- B. ASTM D3273 - Standard Test Method for Resistance to Growth of Mold on the Surface of Interior Coatings in an Environmental Chamber; 2012.
- C. ASTM D5319 - Standard Specification for Glass-Fiber Reinforced Polyester Wall and Ceiling Panels; 2012.
- D. ASTM E84 - Standard Test Method for Surface Burning Characteristics of Building Materials; 2015a.
- E. FM 4880 - Class 1 Fire Rating of Insulated Wall or Wall and Roof/Ceiling Panels, Interior Finish Materials or Coatings and Exterior Wall Systems; 2010.

1.3 SUBMITTALS

- A. See Section 013300 - Submittal Procedures.
- B. Product Data: Provide data on specified products, describing physical and performance characteristics; including sizes, patterns and colors available; and installation instructions.
- C. Samples: Submit two samples 6 by 6 inch in size illustrating material and surface design of panels.
- D. Maintenance Materials: Furnish the following for Owner's use in maintenance of project.

- 1. See Section 016000 - Product Requirements, for additional provisions.

**KOPACHUCK STATE PARK
DAY USE DEVELOPMENT**

1.4 DELIVERY, STORAGE, AND HANDLING

- A. Store panels flat, indoors, on a clean, dry surface. Remove packaging and allow panels to acclimate to room temperature for 48 hours prior to installation.

PART 2 PRODUCTS

2.1 MANUFACTURERS

- A. Glass Fiber Reinforced Plastic Panels:

- 1. Crane Composites, Inc; DESIGNS: www.cranecomposites.com.
- 2. Marlite; Artizan FRP: www.marlite.com.
- 3. Substitutions: See Section 016000 - Product Requirements.

2.2 PANEL SYSTEMS

- A. Wall Panels:

- 1. Panel Size: 4 by 8 feet.
- 2. Panel Thickness: 0.10 inch.
- 3. Surface Design: Patterned, smooth.
- 4. Color: As selected by Architect.
- 5. Attachment Method: Adhesive only, sealant joints, no trim.

2.3 MATERIALS

- A. Panels: Glass fiber reinforced plastic (FRP), complying with ASTM D5319.

- 1. Surface Burning Characteristics: Maximum flame spread index of 25 and smoke developed index of 450; when system tested in accordance with ASTM E84.
- 2. Class 1 fire rated when tested in accordance with FM 4880.
- 3. Mold Resistance: Score of 10, when tested in accordance with ASTM D3273.
- 4. Sanitation and Cleanability: Comply with 9 CFR 416.2.

- B. Trim: Vinyl; color coordinating with panel.

- C. Adhesive: Type recommended by panel manufacturer.

- D. Sealant: Type recommended by panel manufacturer; color matching panel.

**KOPACHUCK STATE PARK
DAY USE DEVELOPMENT**

PART 3 EXECUTION

3.1 EXAMINATION

- A. Verify existing conditions and substrate flatness before starting work.
- B. Verify that substrate conditions are ready to receive the work of this section.

3.2 INSTALLATION – WALLS

- A. Install panels in accordance with manufacturer's instructions.
- B. Cut and drill panels with carbide tipped saw blades, drill bits, or snips.
- C. Apply adhesive to the back side of the panel using trowel as recommended by adhesive manufacturer.
- D. Apply panels to wall with seams plumb and pattern aligned with adjoining panels.
- E. Install panels with manufacturer's recommended gap for panel field and corner joints.
- F. Place trim on panel before fastening edges, as required.
- G. Fill channels in trim with sealant before attaching to panel.
- H. Install trim with adhesive and screws or nails, as required.
- I. Seal gaps at floor, ceiling, and between panels with applicable sealant to prevent moisture intrusion.
- J. Remove excess sealant after paneling is installed and prior to curing.

END OF SECTION 097733

**KOPACHUCK STATE PARK
DAY USE DEVELOPMENT**

SECTION 099113 - EXTERIOR PAINTING

PART 1 GENERAL

1.1 SECTION INCLUDES

- A. Surface preparation.
- B. Field application of paints.
- C. Scope: Finish exterior surfaces exposed to view, unless fully factory-finished and unless otherwise indicated, including the following:
 - 1. Exposed surfaces of steel lintels and ledge angles.
- D. Do Not Paint or Finish the Following Items:
 - 1. Items factory-finished unless otherwise indicated; materials and products having factory-applied primers are not considered factory finished.
 - 2. Items indicated to receive other finishes.
 - 3. Items indicated to remain unfinished.
 - 4. Fire rating labels, equipment serial number and capacity labels, and operating parts of equipment.
 - 5. Non-metallic roofing and flashing.
 - 6. Floors, unless specifically indicated.
 - 7. Glass.
 - 8. Concealed pipes, ducts, and conduits.

1.2 RELATED REQUIREMENTS

- A. Section 055000 - Metal Fabrications: Shop-primed items.

1.3 DEFINITIONS

- A. Conform to ASTM D16 for interpretation of terms used in this section.

1.4 REFERENCE STANDARDS

- A. ASTM D16 - Standard Terminology for Paint, Related Coatings, Materials, and Applications; 2014.

**KOPACHUCK STATE PARK
DAY USE DEVELOPMENT**

- B. MPI (APL) - Master Painters Institute Approved Products List; Master Painters and Decorators Association; current edition, www.paintinfo.com.
 - C. MPI (APSM) - Master Painters Institute Architectural Painting Specification Manual; Current Edition, www.paintinfo.com.
 - D. SSPC-SP 1 - Solvent Cleaning; 2015.
 - E. SSPC-SP 2 - Hand Tool Cleaning; 1982 (Ed. 2004).
- 1.5 SUBMITTALS
- A. See Section 013300 - Submittal Procedures.
 - B. Product Data: Provide complete list of products to be used, with the following information for each:
 - 1. Manufacturer's name, product name and/or catalog number, and general product category (e.g. "alkyd enamel").
 - 2. MPI product number (e.g. MPI #47).
 - 3. Cross-reference to specified paint system(s) product is to be used in; include description of each system.
 - C. Samples: Submit three paper "draw down" samples, 8-1/2 by 11 inches in size, illustrating range of colors available for each finishing product specified.
 - 1. Where sheen is specified, submit samples in only that sheen.
 - 2. Where sheen is not specified, discuss sheen options with Architect before preparing samples, to eliminate sheens definitely not required.
 - 3. Allow 30 days for approval process, after receipt of complete samples by Architect.
 - D. Certification: By manufacturer that paints and finishes comply with VOC limits specified.
 - E. Manufacturer's Instructions: Indicate special surface preparation procedures.
 - F. Maintenance Data: Submit data including finish schedule showing where each product/color/finish was used, product technical data sheets, material safety data sheets (MSDS), care and cleaning instructions, touch-up procedures, repair of painted and finished surfaces, and color samples of each color and finish used.
- 1.6 QUALITY ASSURANCE

**KOPACHUCK STATE PARK
DAY USE DEVELOPMENT**

- A. Manufacturer Qualifications: Company specializing in manufacturing the products specified, with minimum three years documented experience.
- B. Applicator Qualifications: Company specializing in performing the type of work specified with minimum 5 years experience and approved by manufacturer.

1.7 DELIVERY, STORAGE, AND HANDLING

- A. Deliver products to site in sealed and labeled containers; inspect to verify acceptability.
- B. Container Label: Include manufacturer's name, type of paint, brand name, lot number, brand code, coverage, surface preparation, drying time, cleanup requirements, color designation, and instructions for mixing and reducing.
- C. Paint Materials: Store at minimum ambient temperature of 45 degrees F and a maximum of 90 degrees F, in ventilated area, and as required by manufacturer's instructions.

PART 2 PRODUCTS

2.1 MANUFACTURERS

- A. Provide paints and finishes from the same manufacturer to the greatest extent possible.
 - 1. In the event that a single manufacturer cannot provide specified products, minor exceptions will be permitted provided approval by Architect is obtained using the specified procedures for substitutions.
 - 2. Substitution of MPI-approved products by a different manufacturer is preferred over substitution of unapproved products by the same manufacturer.
- B. Paints:
 - 1. Behr Process Corporation: www.behr.com.
 - 2. Benjamin Moore & Co: www.benjaminmoore.com.
 - 3. Cloverdale Paint, Brand Products of Rodda Paint Company: www.cloverdalepaint.com.
 - 4. Miller Paint Company: www.millerpaint.com
 - 5. PPG Paints: www.ppgpaints.com.
 - 6. Rodda Paint Company: www.roddapaint.com.
 - 7. Sherwin-Williams Company: www.sherwin-williams.com.
- C. Primer Sealers: Same manufacturer as top coats.
- D. Substitutions: See Section 016000 - Product Requirements.

2.2 PAINTS AND FINISHES – GENERAL

**KOPACHUCK STATE PARK
DAY USE DEVELOPMENT**

- A. Paints and Finishes: Ready mixed, unless required to be a field-catalyzed paint.
1. Where MPI paint numbers are specified, provide products listed in Master Painters Institute Approved Product List, current edition available at www.paintinfo.com, for specified MPI categories, except as otherwise indicated.
 2. Provide paints and finishes of a soft paste consistency, capable of being readily and uniformly dispersed to a homogeneous coating, with good flow and brushing properties, and capable of drying or curing free of streaks or sags.
 3. Provide materials that are compatible with one another and the substrates indicated under conditions of service and application, as demonstrated by manufacturer based on testing and field experience.
 4. For opaque finishes, tint each coat including primer coat and intermediate coats, one-half shade lighter than succeeding coat, with final finish coat as base color.
 5. Supply each paint material in quantity required to complete entire project's work from a single production run.
 6. Do not reduce, thin, or dilute paint or finishes or add materials unless such procedure is specifically described in manufacturer's product instructions.
- B. Sheens: Provide the sheens specified; where sheen is not specified, sheen will be selected later by Architect from the manufacturer's full line.

2.3 PAINT SYSTEMS – EXTERIOR

- A. Paint E-OP - Exterior Surfaces to be Painted, Unless Otherwise Indicated: Including fiber cement siding and primed metal.
1. Two top coats and one coat primer.
 2. Top Coat(s): Exterior Light Industrial Coating, Water Based; MPI #161, 163, or 164.
 3. Top Coat Sheen:
 - a. Semi-Gloss: MPI gloss level 5; use this sheen at all locations.
 4. Primer: As recommended by top coat manufacturer for specific substrate.
- B. Paint FCE-OP-2L - Fiber Cement Siding, Opaque, Acrylic, 2 Coat; MPI#15
1. Two coats acrylic.

2.4 PRIMERS

- A. Primers: Provide the following unless other primer is required or recommended by manufacturer of top coats.

2.5 ACCESSORY MATERIALS

**KOPACHUCK STATE PARK
DAY USE DEVELOPMENT**

- A. Accessory Materials: Provide primers, sealers, cleaning agents, cleaning cloths, sanding materials, and clean-up materials as required for final completion of painted surfaces.
- B. Patching Material: Latex filler.
- C. Fastener Head Cover Material: Latex filler.

PART 3 EXECUTION

3.1 EXAMINATION

- A. Do not begin application of paints and finishes until substrates have been properly prepared.
- B. Verify that surfaces are ready to receive work as instructed by the product manufacturer.
- C. Examine surfaces scheduled to be finished prior to commencement of work. Report any condition that may potentially effect proper application.
- D. Test shop-applied primer for compatibility with subsequent cover materials.

3.2 PREPARATION

- A. Clean surfaces thoroughly and correct defects prior to application.
- B. Prepare surfaces using the methods recommended by the manufacturer for achieving the best result for the substrate under the project conditions.
- C. Remove or mask surface appurtenances, including electrical plates, hardware, light fixture trim, escutcheons, and fittings, prior to preparing surfaces for finishing.
- D. Seal surfaces that might cause bleed through or staining of topcoat.
- E. Remove mildew from impervious surfaces by scrubbing with solution of tetra-sodium phosphate and bleach. Rinse with clean water and allow surface to dry.
- F. Fiber Cement Siding: Remove dirt, dust and other foreign matter with a stiff fiber brush. Do not coat surfaces if moisture content or alkalinity of surfaces to be coated exceeds that permitted in manufacturer's written instructions.
- G. Exterior Gypsum Board: Fill minor defects with exterior filler compound. Spot prime defects after repair.

**KOPACHUCK STATE PARK
DAY USE DEVELOPMENT**

H. Galvanized Surfaces:

1. Remove surface contamination and oils and wash with solvent according to SSPC-SP
2. Prepare surface according to SSPC-SP 2.

I. Ferrous Metal:

1. Solvent clean according to SSPC-SP 1.
2. Shop-Primed Surfaces: Sand and scrape to remove loose primer and rust. Feather edges to make touch-up patches inconspicuous. Clean surfaces with solvent. Prime bare steel surfaces.

3.3 APPLICATION

- A. Apply products in accordance with manufacturer's written instructions and recommendations in "MPI Architectural Painting Specification Manual".
- B. Do not apply finishes to surfaces that are not dry. Allow applied coats to dry before next coat is applied.
- C. Apply each coat to uniform appearance.
- D. Dark Colors and Deep Clear Colors: Regardless of number of coats specified, apply additional coats until complete hide is achieved.
- E. Sand metal surfaces lightly between coats to achieve required finish.
- F. Vacuum clean surfaces of loose particles. Use tack cloth to remove dust and particles just prior to applying next coat.
- G. Reinstall electrical cover plates, hardware, light fixture trim, escutcheons, and fittings removed prior to finishing.

3.4 CLEANING

- A. Collect waste material that could constitute a fire hazard, place in closed metal containers, and remove daily from site.

3.5 PROTECTION

- A. Protect finishes until completion of project.
- B. Touch-up damaged finishes after Substantial Completion.

**KOPACHUCK STATE PARK
DAY USE DEVELOPMENT**

END OF SECTION 099113

**KOPACHUCK STATE PARK
DAY USE DEVELOPMENT**

SECTION 099123 - INTERIOR PAINTING

PART 1 GENERAL

1.1 SECTION INCLUDES

- A. Surface preparation.
- B. Field application of paints.
- C. Scope: Finish interior surfaces exposed to view, unless fully factory-finished and unless otherwise indicated.
- D. Do Not Paint or Finish the Following Items:
 - 1. Items factory-finished unless otherwise indicated; materials and products having factory-applied primers are not considered factory finished.
 - 2. Items indicated to receive other finishes.
 - 3. Items indicated to remain unfinished.
 - 4. Fire rating labels, equipment serial number and capacity labels, bar code labels, and operating parts of equipment.
 - 5. Stainless steel, anodized aluminum, bronze, terne coated stainless steel, and lead items.
 - 6. Floors, unless specifically indicated.
 - 7. Ceramic and other tiles.
 - 8. Glass.
 - 9. Concealed pipes, ducts, and conduits.

1.2 RELATED REQUIREMENTS

- A. Section 055000 - Metal Fabrications: Shop-primed items.
- B. Section 099113 - Exterior Painting.

1.3 DEFINITIONS

- A. Conform to ASTM D16 for interpretation of terms used in this section.

1.4 REFERENCE STANDARDS

- A. ASTM D16 - Standard Terminology for Paint, Related Coatings, Materials, and Applications; 2014.

**KOPACHUCK STATE PARK
DAY USE DEVELOPMENT**

- B. MPI (APL) - Master Painters Institute Approved Products List; Master Painters and Decorators Association; current edition, www.paintinfo.com.
- C. MPI (APSM) - Master Painters Institute Architectural Painting Specification Manual; Current Edition, www.paintinfo.com.
- D. SSPC-SP 1 - Solvent Cleaning; 2015.
- E. SSPC-SP 2 - Hand Tool Cleaning; 1982 (Ed. 2004).
- F. SSPC-SP 6 - Commercial Blast Cleaning; 2007.

1.5 SUBMITTALS

- A. See Section 013300 - Submittal Procedures.
- B. Product Data: Provide complete list of products to be used, with the following information for each:
 - 1. Manufacturer's name, product name and/or catalog number, and general product category (e.g. "alkyd enamel").
 - 2. MPI product number (e.g. MPI #47).
 - 3. Cross-reference to specified paint system(s) product is to be used in; include description of each system.
- C. Samples: Submit three paper "draw down" samples, 8-1/2 by 11 inches in size, illustrating range of colors available for each finishing product specified.
 - 1. Where sheen is specified, submit samples in only that sheen.
 - 2. Where sheen is not specified, discuss sheen options with Architect before preparing samples, to eliminate sheens definitely not required.
- D. Samples: Submit two paper chip samples, 8 by 10 inch in size illustrating range of colors and textures available for each surface finishing product scheduled.
- E. Certification: By manufacturer that paints and finishes comply with VOC limits specified.
- F. Manufacturer's Instructions: Indicate special surface preparation procedures.
- G. Maintenance Materials: Furnish the following for Owner's use in maintenance of project.
 - 1. See Section 016000 - Product Requirements, for additional provisions.
 - 2. Extra Paint and Finish Materials: 1 gallon of each color; from the same product run, store where directed.

**KOPACHUCK STATE PARK
DAY USE DEVELOPMENT**

3. Label each container with color in addition to the manufacturer's label.

1.6 QUALITY ASSURANCE

- A. Manufacturer Qualifications: Company specializing in manufacturing the products specified, with minimum three years documented experience.
- B. Applicator Qualifications: Company specializing in performing the type of work specified with minimum 5 years experience and approved by manufacturer.

1.7 DELIVERY, STORAGE, AND HANDLING

- A. Deliver products to site in sealed and labeled containers; inspect to verify acceptability.
- B. Container Label: Include manufacturer's name, type of paint, brand name, lot number, brand code, coverage, surface preparation, drying time, cleanup requirements, color designation, and instructions for mixing and reducing.
- C. Paint Materials: Store at minimum ambient temperature of 45 degrees F and a maximum of 90 degrees F, in ventilated area, and as required by manufacturer's instructions.

1.8 FIELD CONDITIONS

- A. Do not apply materials when surface and ambient temperatures are outside the temperature ranges required by the paint product manufacturer.
- B. Follow manufacturer's recommended procedures for producing best results, including testing of substrates, moisture in substrates, and humidity and temperature limitations.
- C. Do not apply materials when relative humidity exceeds 85 percent; at temperatures less than 5 degrees F above the dew point; or to damp or wet surfaces.
- D. Minimum Application Temperatures for Paints: 50 degrees F for interiors unless required otherwise by manufacturer's instructions.
- E. Provide lighting level of 80 ft candles measured mid-height at substrate surface.

PART 2 PRODUCTS

2.1 MANUFACTURERS

- A. Provide paints and finishes from the same manufacturer to the greatest extent possible.

**KOPACHUCK STATE PARK
DAY USE DEVELOPMENT**

1. In the event that a single manufacturer cannot provide specified products, minor exceptions will be permitted provided approval by Architect is obtained using the specified procedures for substitutions.
2. Substitution of MPI-approved products by a different manufacturer is preferred over substitution of unapproved products by the same manufacturer.

B. Paints:

1. Behr Process Corporation: www.behr.com.
2. Benjamin Moore & Co: www.benjaminmoore.com.
3. Cloverdale Paint, Brand Products of Rodda Paint Company: www.cloverdalepaint.com.
4. Miller Paint Company: www.millerpaint.com.
5. PPG Paints: www.ppgpaints.com.
6. Rodda Paint Co: www.rodmapaint.com.
7. Sherwin-Williams Company: www.sherwin-williams.com.

C. Primer Sealers: Same manufacturer as top coats.

D. Substitutions: See Section 016000 - Product Requirements.

2.2 PAINTS AND FINISHES – GENERAL

A. Paints and Finishes: Ready mixed, unless intended to be a field-catalyzed paint.

1. Where MPI paint numbers are specified, provide products listed in Master Painters Institute Approved Product List, current edition available at www.paintinfo.com, for specified MPI categories, except as otherwise indicated.
2. Provide paints and finishes of a soft paste consistency, capable of being readily and uniformly dispersed to a homogeneous coating, with good flow and brushing properties, and capable of drying or curing free of streaks or sags.
3. Provide materials that are compatible with one another and the substrates indicated under conditions of service and application, as demonstrated by manufacturer based on testing and field experience.
4. For opaque finishes, tint each coat including primer coat and intermediate coats, one-half shade lighter than succeeding coat, with final finish coat as base color.
5. Supply each paint material in quantity required to complete entire project's work from a single production run.
6. Do not reduce, thin, or dilute paint or finishes or add materials unless such procedure is specifically described in manufacturer's product instructions.

B. Sheens: Provide the sheens specified; where sheen is not specified, sheen will be selected later by Architect from the manufacturer's full line.

**KOPACHUCK STATE PARK
DAY USE DEVELOPMENT**

2.3 PAINT SYSTEMS – INTERIOR

- A. Paint I-OP - Interior Surfaces to be Painted, Unless Otherwise Indicated: Including gypsum board.
 - 1. Two top coats and one coat primer.
 - 2. Top Coat(s): High Performance Architectural Interior Latex; MPI #138, 139, 140, or 141.
 - 3. Top Coat Sheen:
 - a. Satin: MPI gloss level 4; use this sheen at all locations.

- B. Paint I-OP-MD-DT - Medium Duty Door/Trim: For surfaces subject to frequent contact by occupants, including metals:
 - 1. Medium duty applications include door frames.
 - 2. Two top coats and one coat primer.
 - 3. Top Coat(s): High Performance Architectural Interior Latex; MPI #139, 140, or 141.
 - 4. Top Coat Sheen:
 - a. Semi-Gloss: MPI gloss level 5; use this sheen at all locations.
 - 5. Primer: As recommended by top coat manufacturer for specific substrate.

- C. Paint I-OP-MD-WC - Medium Duty Vertical and Overhead: Including gypsum board, uncoated steel, shop primed steel, and galvanized steel.
 - 1. Two top coats and one coat primer.
 - 2. Use this system for all wet areas, including all restrooms, kitchens, janitor closets, and dirty linen rooms.
 - 3. Top Coat(s): High Performance Architectural Interior Latex; MPI #138, 139, 140, or 141.
 - 4. Top Coat Sheen:
 - a. Semi-Gloss: MPI gloss level 5; use this sheen at all locations.
 - 5. Primer: As recommended by top coat manufacturer for specific substrate.

2.4 PRIMERS

- A. Primers: Provide the following unless other primer is required or recommended by manufacturer of top coats.

2.5 ACCESSORY MATERIALS

- A. Accessory Materials: Provide primers, sealers, cleaning agents, cleaning cloths, sanding materials, and clean-up materials as required for final completion of painted surfaces.

- B. Patching Material: Latex filler.

**KOPACHUCK STATE PARK
DAY USE DEVELOPMENT**

- C. Fastener Head Cover Material: Latex filler.

PART 3 EXECUTION

3.1 EXAMINATION

- A. Verify that surfaces are ready to receive work as instructed by the product manufacturer.
- B. Examine surfaces scheduled to be finished prior to commencement of work. Report any condition that may potentially affect proper application.
- C. Test shop-applied primer for compatibility with subsequent cover materials.
- D. Measure moisture content of surfaces using an electronic moisture meter. Do not apply finishes unless moisture content of surfaces are below the following maximums:
 - 1. Gypsum Wallboard: 12 percent.

3.2 PREPARATION

- A. Clean surfaces thoroughly and correct defects prior to application.
- B. Prepare surfaces using the methods recommended by the manufacturer for achieving the best result for the substrate under the project conditions.
- C. Remove or mask surface appurtenances, including electrical plates, hardware, light fixture trim, escutcheons, and fittings, prior to preparing surfaces or finishing.
- D. Seal surfaces that might cause bleed through or staining of topcoat.
- E. Gypsum Board: Fill minor defects with filler compound. Spot prime defects after repair.
- F. Galvanized Surfaces:
 - 1. Remove surface contamination and oils and wash with solvent according to SSPC-SP
 - 2. Prepare surface according to SSPC-SP 2.
- G. Ferrous Metal:
 - 1. Solvent clean according to SSPC-SP 1.

**KOPACHUCK STATE PARK
DAY USE DEVELOPMENT**

2. Shop-Primed Surfaces: Sand and scrape to remove loose primer and rust. Feather edges to make touch-up patches inconspicuous. Clean surfaces with solvent. Prime bare steel surfaces. Re-prime entire shop-primed item.
3. Remove rust, loose mill scale, and other foreign substances using methods recommended in writing by paint manufacturer and blast cleaning according to SSPC-SP 6 "Commercial Blast Cleaning". Protect from corrosion until coated.

H. Metal Doors to be Painted: Prime metal door top and bottom edge surfaces.

3.3 APPLICATION

- A. Apply products in accordance with manufacturer's written instructions and recommendations in "MPI Architectural Painting Specification Manual".
- B. Do not apply finishes to surfaces that are not dry. Allow applied coats to dry before next coat is applied.
- C. Apply each coat to uniform appearance in thicknesses specified by manufacturer.
- D. Sand wood and metal surfaces lightly between coats to achieve required finish.
- E. Vacuum clean surfaces of loose particles. Use tack cloth to remove dust and particles just prior to applying next coat.
- F. Reinstall electrical cover plates, hardware, light fixture trim, escutcheons, and fittings removed prior to finishing.

3.4 CLEANING

- A. Collect waste material that could constitute a fire hazard, place in closed metal containers, and remove daily from site.

3.5 PROTECTION

- A. Protect finishes until completion of project.
- B. Touch-up damaged finishes after Substantial Completion.

END OF SECTION 099123

**KOPACHUCK STATE PARK
DAY USE DEVELOPMENT**

SECTION 101101 - VISUAL DISPLAY BOARDS

PART 1 GENERAL

1.1 SECTION INCLUDES

- A. Combination Markerboard/Tackboard

1.2 RELATED REQUIREMENTS

- A. Section 061000 - Rough Carpentry: Blocking and supports.

1.3 REFERENCE STANDARDS

- A. ANSI A208.1 - American National Standard for Particleboard; 2009.
- B. ASTM A424/A424M - Standard Specification for Steel, Sheet, for Porcelain Enameling; 2009a.
- C. ASTM E84 - Standard Test Method for Surface Burning Characteristics of Building Materials; 2015a.

1.4 SUBMITTALS

- A. See Section 013300 - Submittal Procedures.
- B. Product Data: Provide manufacturer's data.
- C. Shop Drawings: Indicate wall elevations, dimensions, joint locations, special anchor details.

1.5 QUALITY ASSURANCE

- A. Manufacturer Qualifications: Company specializing in manufacturing the products specified in this section with minimum three years documented experience.

PART 2 PRODUCTS

2.1 MANUFACTURERS

- A. Visual Display Boards:
 - 1. PBS Supply Company; www.pbssupply.com.
 - 2. Substitutions: See Section 0160 00 - Product Requirements.

**KOPACHUCK STATE PARK
DAY USE DEVELOPMENT**

B. Combination Markerboard/Tackboard

1. Manufacturer: Claridge
2. Product: LCS5046; white porcelain enamel markerboard writing surface on the left; natural tan cork tack surface on the right.
3. Overall Size: 4 foot high x 6 foot wide.
4. Full length marker tray, map rail with cork insert, and 2 map hooks
5. Satin anodize aluminum trim.
6. Angle clip hangers.
7. 4 assorted LCS markers and one eraser cloth.

PART 3 EXECUTION

3.1 MANUFACTURERS

- A. Verify that field measurements are as indicated.
- B. Verify that internal wall blocking is ready to receive work and positioning dimensions are as indicated on shop drawings.

3.2 INSTALLATION

- A. Install boards in accordance with manufacturer's instructions.
- B. Verify installation locations.
- C. Install with top of chalk tray at 30 inches above finished floor.
- D. Secure units level and plumb.

3.3 CLEANING

- A. Clean board surfaces in accordance with manufacturer's instructions.
- B. Cover with protective cover, taped to frame.
- C. Remove temporary protective cover at Date of Substantial Completion.

END OF SECTION 101101

**KOPACHUCK STATE PARK
DAY USE DEVELOPMENT**

SECTION 101400 - SIGNS

PART 1 - GENERAL

1.1 RELATED DOCUMENTS

- A. Drawings and general provisions of the Contract, including General Conditions and Division 1 Specifications, apply to this Section.

1.2 SUMMARY

- A. This Section includes:
 - 1. Regulatory and informational signs.

1.3 RELATED WORK SPECIFIED ELSEWHERE

- A. Section 055000 – Metal Fabrications.
- B. Section 321216 – Asphalt Concrete Pavement and Pavement Marking.
- C. Section 321313 – Cast-in-Place Concrete.

1.4 QUALITY ASSURANCE

- A. The Contractor shall attend a pre-construction conference with the Owner's Representative prior to placing the signs.
- B. Standards: Conform to the American Institute of Steel Construction's (AISC) "Specifications for the Design, Fabrication and Erection of Structural Steel for Buildings" and "Code of Standard Practice for Steel Buildings and Bridges;" and to the American Welding Society's (AWS) "Standard Code for Welding in Building Construction."

1.5 SUBMITTALS

- A. Submit composite data sheets on posts, caps, and collars.

1.6 ALTERNATES

- A. See Bid Form for possible effect on this Section.

**KOPACHUCK STATE PARK
DAY USE DEVELOPMENT**

PART 2 - PRODUCTS

2.1 REGULATORY SIGNS

- A. Signs: Conform to the latest edition of the "Manual on Uniform Traffic Control Devices" (MUTCD) unless stated otherwise on the plans (U.S. Department of Transportation Federal Highway Administration.).
- B. Wood Post (Where Shown): Pacific-Coast Douglas Fir select structural treated with AZCA (Chemonite) to .4 lb./cu. Ft. retention and kiln dried to 19% moisture content after treatment. Posts to be treated after cutting to specified lengths and chamfered.
- C. Backing: ¼" galvanized steel plates sized to match full size of the sign. Ease all edges.
- D. Post Caps: Wagner 3" Type C flush, weld-on cap No. 3226-4. 1-800-786-2111.
- E. Post Collars: Wagner 3" plain flange galvanized steel, No. 1700T. 1-800-786-2111.
- F. Fasteners:
 - 1. A galvanized tamper-proof screws.
- G. Footings: Class 3000 concrete.

2.2 INFORMATIONAL SIGNS

- A. Powder Coat Finish: Shall be an electrostatically applied polyester powder. All components will be free of sharp edges and excess weld spatter. The coating shall meet the following:
 - 1. 3.0 – 5.0 mil thickness and over cured between 375° to 425° F.
 - 2. Pencil Hardness: H, ASTM D3363.
 - 3. Impact: ASTM D2794.
 - 4. Wedge Bend: ASTM D522.
 - 5. Adhesion: Cross hatch ASTM D3359 and knife scratch ASTM D2197.
 - 6. Environmental: Stain resistance ASTM D1308.
 - 7. Salt Spray: ASTM B117 and Fadometer 300 hrs with no loss of gloss.
 - 8. Overbake Stability: 100% at 400° F.
 - 9. Color: To be selected.
- B. Copy: White letters and arrows on colored background, both sides. See Contract Drawings for location and copy.
- C. Wood Post (Where Shown): Pacific-Coast Douglas Fir select structural treated with AZCA (Chemonite) to .4 lb./cu. Ft. retention and kiln dried to 19% moisture content after treatment. Posts to be treated after cutting to specified lengths and chamfered.
- D. Fasteners: Galvanized tamper proof screws.
- E. Footings: Class 3000 concrete.

**KOPACHUCK STATE PARK
DAY USE DEVELOPMENT**

PART 3 - EXECUTION

3.1 PREPARATION

- A. Preparation: Signs on posts must be placed prior to concrete walks and asphalt.

3.2 REGULATORY SIGNS

- A. Mounting: Set height in accordance with WSDOT Standard Specifications for signs on steel posts. Set posts in concrete as detailed on Contract Drawings. Use block out and expansion joint material around footings where signs occur in concrete walks. Place collars and caps.
- B. Copy in accordance with USDOT/FMA "Manual on Uniform Traffic Control Devices" (MUTCD).

3.3 INFORMATIONAL SIGNS

- A. Provide shop drawing for signs and copy.
- B. Mount as shown on Contract Drawings.

END OF SECTION 101400

**KOPACHUCK STATE PARK
DAY USE DEVELOPMENT**

SECTION 101423 - SIGNAGE

PART 1 - GENERAL

1.1 SUMMARY

- A. Section Includes:
 - 1. Restroom signage (Interior and exterior)

1.2 REFERENCE STANDARDS

- A. 36 CFR 1191-American with Disabilities Act (ADA) Accessibility Guidelines for Buildings and Facilities; Architectural Barriers Act (ABA) Accessibility Guidelines; current edition.
- B. ADA Standards-Americans with Disabilities (ADA) Standards for Accessible Design, 2010.
- C. ICC A117.1- Accessible and Usable Buildings and Facilities; 2009.

1.3 SUBMITTALS

- A. Product Data: Manufacturer's printed product literature for each type of sign, indicating sign styles, font, foreground, and background colors, locations, overall dimensions of each sign.
- B. Signage Schedule: Provide information sufficient to completely define each sign for fabrication, including room number, room name, other text to be applied, sign, and letter sizes, fonts, and colors.
- C. Shop Drawings: For restroom signage.
 - 1. Include fabrication and installation details and attachments to other work.
 - 2. Show sign mounting heights, locations of supplementary supports to be provided by other installers, and accessories.
 - 3. Show message list, typestyles, graphic elements Braille and layout for each sign.
- D. Samples: For each exposed product and for each color and texture specified.

PART 2 - PRODUCTS

2.1 FLAT SIGNS

- A. Flat Sign: Sign with smooth, uniform surfaces; with message and characters having uniform faces, sharp corners, and precisely formed lines and profiles; and as follows:

**KOPACHUCK STATE PARK
DAY USE DEVELOPMENT**

1. Best Sign Systems, Inc.
2. Cosco Industries (ADA) signs); ADA Series 2
3. Mohawk Sign Systems, Inc.
4. Or approved equal.

B. FLAT SIGNS:

1. Tactile characters/symbols shall be raised 1/32 inch from sign face. Signs shall be of one-piece construction; added-on and /or engraved characters are unacceptable.
2. Lettering style shall be Standard Medium, upper case, or other sans serif or simple serif typeface.
3. Sizes of letters and numbers shall be as follows:
 - a. Lettering for room usage and directional identification shall be 5/8" high,
 - b. Lettering for restroom identification shall be 5/8" high, corresponding symbols shall be 3" high.
4. Text shall be accompanied by Grade 2 braille.
5. All letters, numbers and /or symbols shall contrast with their background-either light characters on a dark background or dark characters on a light background.
6. Characters and background shall have matte finish.
7. Colors to be selected by Architect from manufacturer's standard colors.

2.2 FLAT SIGN SCHEDULE

- A. 6"x8" restroom sign with ADA symbol of access.**
1. The sign shall be alongside the door at the latch side.
 2. Color: Blue with white lettering.
 3. See drawings for locations.
 4. Install signs in compliance with ADA.

2.3 ACCESSORIES

- A. Fasteners and Anchors:** Manufacturer's standard as required for secure anchorage of signs, noncorrosive and compatible with each material joined, and complying with the following unless otherwise indicated:
1. For exterior exposure, furnish stainless-steel devices.
- B. Adhesive:** As recommended by sign manufacturer.

PART 3 - EXECUTION

3.1 INSTALLATION

- A. General:** Install signs using mounting methods indicated and according to manufacturer's written instructions.

**KOPACHUCK STATE PARK
DAY USE DEVELOPMENT**

1. Install signs level, plumb, true to line, and at locations and heights indicated, with sign surfaces free of distortion and other defects in appearance.
2. Install signs so they do not protrude or obstruct according to the accessibility standard.
3. Before installation, verify that sign surfaces are clean and free of materials or debris that would impair installation.
4. Corrosion Protection: Coat concealed surfaces of exterior aluminum in contact with grout, concrete, masonry, wood, or dissimilar metals, with a heavy coat of bituminous paint.

END OF SECTION 101423

**KOPACHUCK STATE PARK
DAY USE DEVELOPMENT**

SECTION 102813 – TOILET ACCESSORIES

PART 1 –GENERAL

1.1 RELATED DOCUMENTS

- A. Drawings and general provisions of the Contract, including General Conditions and Division 1 Specification Sections, apply to this Section.

1.2 SUMMARY

- A. This Section includes the following:
 - 1. Toilet accessories
 - 2. Childcare accessories.
 - 3. Under lavatory guards.
 - 4. Custodial accessories.
 - 5. High speed air hand dryers

1.3 SUBMITTALS

- A. Product Data: Include construction details, material descriptions and thicknesses, dimensions, profiles, fastening and mounting methods, specified options, and finishes for each type of accessory specified.
- B. Maintenance Data: For accessories to include in maintenance manuals specified in Division 1. Provide lists of replacement parts and service recommendations.

1.4 QUALITY ASSURANCE

- A. Source Limitations: Provide products of same manufacturer for each type of accessory unit and for units exposed to view in same areas, unless otherwise approved by Architect.
- B. Product Options: Accessory requirements, including those for materials, finishes, dimensions, capacities, and performance, are established by specific products indicated in the Toilet and Bath Accessory Schedule.
 - 1. Other manufacturers' products with equal characteristics may be considered.
 - 2. Do not modify aesthetic effects, as judged solely by Architect, except with Architect's approval. Where modifications are proposed, submit comprehensive explanatory data to Architect for review.

**KOPACHUCK STATE PARK
DAY USE DEVELOPMENT**

1.5 COORDINATION

- A. Coordinate accessory locations with other work to prevent interference with clearances required for access by disabled persons, proper installation, adjustment, operation, cleaning, and servicing of accessories.
- B. Deliver inserts and anchoring devices set into concrete or masonry as required to prevent delaying the Work.

1.6 WARRANTY

- A. General Warranty: Provide 1 year warranty on all accessories from the date of Physical Completion. For mirrors, extend same warranty for 5 years total.

PART 2 – PRODUCTS

2.1 TOILET ROOM ACCESSORIES

- A. Manufacturers: Subject to compliance with requirements, provide accessories by one of the following:
 - 1. Toilet and Bath Accessories:
 - a. Bobrick Washroom Equipment, Inc.
 - b. American Specialties, Inc.
- B. Products: Subject to compliance with requirements, provide products indicated for each designation in the Toilet and Bath Accessory Schedule at the end of Part 3 and the drawings.

2.2 MATERIALS

- A. Stainless Steel: ASTM A 666, Type 304, with No. 4 finish (satin), in 0.0312-inch (0.8-mm) minimum nominal thickness, unless otherwise indicated.
- B. Sheet Steel: ASTM A 366/A 366M, cold rolled, commercial quality, 0.0359-inch (0.9-mm) minimum nominal thickness; surface preparation and metal pretreatment as required for applied finish.
- C. Galvanized Steel Sheet: ASTM A 653/A 653M, G60 (Z180).
- D. Chromium Plating: ASTM B 456, Service Condition Number SC 2 (moderate service), nickel plus chromium electrodeposited on base metal.
- E. Mirror Glass: ASTM C 1036, Type I, Class 1, Quality q2, nominal 6.0 mm thick, with silvering, electroplated copper coating, and protective organic coating complying with FS DD-M-411.

**KOPACHUCK STATE PARK
DAY USE DEVELOPMENT**

- F. Galvanized Steel Mounting Devices: ASTM A 153/A 153M, hot-dip galvanized after fabrication.
- G. Fasteners: Screws, bolts, and other devices of same material as accessory unit, tamper and theft resistant when exposed, and of galvanized steel when concealed.

2.3 FABRICATION

- A. General: Names or labels are not permitted on exposed faces of accessories. On interior surface not exposed to view or on back surface of each accessory, provide printed, waterproof label or stamped nameplate indicating manufacturer's name and product model number.
- B. Surface-Mounted Toilet Accessories: Unless otherwise indicated, fabricate units with tight seams and joints, and exposed edges rolled. Hang doors and access panels with continuous stainless-steel hinge. Provide concealed anchorage where possible.
- C. Mirror-Unit Hangers: Provide mirror-unit mounting system that permits rigid, tamper- and theft- resistant installation, as follows:
 - 1. One-piece, galvanized steel, wall-hanger device with spring-action locking mechanism to hold mirror unit in position with no exposed screws or bolts.
 - 2. Heavy-duty wall brackets of galvanized steel, equipped with concealed locking devices requiring a special tool to remove.
 - 3. Use construction adhesive with mirror-unit hangers.
- D. Keys: Provide universal keys for internal access to accessories for servicing and resupplying. Provide minimum of six keys to Owner's representative.

PART 3 – EXECUTION

3.1 INSTALLATION

- A. Install accessories according to manufacturers' written instructions, using fasteners appropriate to substrate indicated and recommended by unit manufacturer. Install units level, plumb, and firmly anchored in locations and at heights indicated.
- B. Secure mirrors to walls in concealed, tamper-resistant manner with special hangers, toggle bolts, or screws. Set units level, plumb, and square at locations indicated, according to manufacturer's written instructions for substrate indicated.
- C. Install grab bars to withstand a downward load of at least 250 lbf (1112 N), when tested according to method in ASTM F 446.

3.2 ADJUSTING AND CLEANING

- A. Adjust accessories for unencumbered, smooth operation and verify that mechanisms function properly. Replace damaged or defective items.

**KOPACHUCK STATE PARK
DAY USE DEVELOPMENT**

- B. Remove temporary labels and protective coatings.
- C. Clean and polish exposed surfaces according to manufacturer's written recommendations.

3.3 TOILET ROOM ACCESSORY SCHEDULE

- A. Paper Towel Dispenser/Waste Receptacle:
 - 1. Furnish by Owner, Install by Contractor (F.O.I.C.)
- B. Toilet Tissue Dispenser:
 - 1. Furnish by Owner, Install by Contractor (F.O.I.C.)
- C. Soap Dispenser:
 - 1. Furnish by Owner. Install by Contractor (F.O.I.C.)
- D. Grab Bars: Provide stainless-steel grab bar complying with the following:
 - 1. Products: American Specialties, Inc., in lengths indicated on drawings.
 - 2. Stainless-Steel Nominal Thickness: 18 gauge.
 - 3. Mounting: Concealed flanges welded to tubing with snap-on cover for concealed mounting.
 - 4. Gripping Surfaces: Non-slip finish
- E. Mirror Unit: Provide channel mirror unit sized to fit opening complying with the following:
 - 1. Provide: Bobrick B-165 2436, 24" x 36". Mount mirror to wall with construction adhesive as manufactured by Loctite PL 520 Mirror Construction Adhesive or approved equal.

3.4 CUSTODIAL ACCESSORIES

- A. Utility Shelf with mop/broom holders and rag hooks
 - 1. Products: Bobrick B-239 x 34. Quantity: per drawings.

3.5 UNDER LAVATORY GUARDS

- A. Manufacturers: Subject to compliance with requirements, provide products by one of the following:
 - 1. Plumberex Speciality Products, Inc.
 - 2. Truebro by IPS Corporation.

**KOPACHUCK STATE PARK
DAY USE DEVELOPMENT**

3.6 CHILDCARE ACCESSORIES

- A. Manufacturers: Subject to compliance with requirements, provide products by one of the following:
1. Koala Kare Products; a division of Bobrick Washroom Equipment, Inc. or approved equal. Model #: KB200
 - a. Description: Horizontal unit that opens down from stored position and with child-protection strap. Engineered to support a minimum of 250 pound static load when opened.
 - b. Mounting: Surface mounted, with unit projecting not more than 4 inches from wall when closed.
 - c. Operation: By pneumatic shock absorbing mechanism.
 - d. Material and Finish: High density polyethylene in manufacturer's standard color.
 - e. Liner Dispenser: Built in.

3.7 HIGH SPEED AIR HAND DRYERS (AT DAY USE BUILDING LOWER LEVEL TOILETS & RESTROOM BUILDING)

- A. Manufacturer: Subject to compliance with requirements, provide product by:
1. Excel Dryer, Inc. or approved equal.
 2. Description: High speed, warm air hand dryer for rapid hand drying.
 3. Mount sensor activated with timed power cut-off switch.
 - a. Average dry time: 8 seconds.
 5. Cover Material and Finish: XL-SB, brushed stainless steel.
 6. Electrical Requirements: Confirm electrical requirements with A/E.

3.8 COAT HOOKS

- A. See Drawings for Coat Hook :
1. Manufacturer: ALNO
 2. Model#: A8980, Euro Series, 7/8" tall, single prong hook, bronze.

3.9 SANITARY NAPKIN RECEPTACLE

- A. "American Specialties, polyethylene receptacle, wall mount. McMaster-Carr #2866K51, or similar.

END OF SECTION 102813

**KOPACHUCK STATE PARK
DAY USE DEVELOPMENT**

SECTION 103100 MANUFACTURED GAS FIREPLACE

PART 1 - GENERAL

1.1 SUMMARY

A. Section Includes:

1. Manufactured indoor gas fireplace.
2. Indoor gas log set.
3. Gas fireplace controls.

1.2 REFERENCES

- A. ANSI Z21.44-Gas-Fired Gravity and Fan Type Direct Vent Wall Furnaces
- B. ANSI Z21.50-Vented Decorative Gas Appliances
- C. ANSI Z223.1-National Fuel Gas Code.
- D. CSA 2.22b-Vented Gas Fireplaces.
- E. CSA 2.33-Vented Gas Fireplace Heaters.
- F. UL 127-Standard for Factory-Built Fireplaces.
- G. UL 907-Standard for Fireplace Accessories.
- H. UL 1482-Standard for Safety for Solid-Fuel Type Room Heaters.
- I. ANSI Z97.1-Tempered Glass Requirements

1.3 SUBMITTALS

A. Product Data: Manufacturer's data sheets.

1. Preparation instructions and recommendations.
2. Storage and handling requirements and recommendations.
3. Installation methods.

B. Shop Drawings: Provide drawing of required clearances, rough-in of enclosure and utilities.

C. Verification Samples: For each finish product specified, two samples, minimum size 6 inches square representing actual sample.

**KOPACHUCK STATE PARK
DAY USE DEVELOPMENT**

1.4 QUALITY ASSURANCE

- A. Manufacturer Qualifications: Minimum 5 years experience manufacturing similar products.
- B. Installer Qualifications: Minimum 2 years experience installing similar products.

1.5 PRE-INSTALLATION MEETING

- A. Convene minimum two weeks prior to starting work of this section.

1.6 DELIVERY, STORAGE, AND HANDLING

- A. Deliver and store products in manufacturer's unopened packaging bearing the brand name and manufacturer's identification until ready for installation.

1.7 SEQUENCING

- A. Ensure that products of this section are supplied to affected trades in time to prevent interruption of construction progress.

1.8 WARRANTY

- A. Warranty: Provide manufacturer's standard warranty against defects in materials and workmanship.

PART 2 - PRODUCTS

2.1 MANUFACTURERS

- A. Basis of Design: Products by Majestic, distributor located at Firecrest Hearth and Home, 6920 22nd St. SW, University Place, WA 98466, (253)564-0680.
- B. Substitution for manufacturer as listed above. See Section 016000-Product Requirements.

2.2 FIREPLACE-GAS-SINGLE SIDE

- A. Model: Marquis II 42 Single-sided:
 - 1. Size: Unit Front Width: 67 inches. Framing Front Width: 65-9/16 inches. Unit Back Width: 65-5/16 inches. Unit Height: 62-5/8 inches. Framing Height: 61 inches. Unit Depth: 24 inches. Framing Depth: 24 inches. Glass Size: 41-7/8 inches x 39-1/16 inches.
 - 2. BTU/Hour Input: 23,500-47,500 Btu/Hour Input (LP).
 - 3. IntelliFire Touch Ignition.
 - 4. LED accent lighting.
 - 5. ClearView ceramic glass.

**KOPACHUCK STATE PARK
DAY USE DEVELOPMENT**

6. Ceramic fiber split logs.
7. Gas flex connector.
8. Junction box.
9. Controls: RC400. Touchscreen remote.
10. Finishing Package: Firescreen Front-Black.
11. Panels: GLMQ hearth brick and top with reflective black glass walls.

B. MANTELS-FLUSH-WOOD

1. Battlefield “C” Flush Mantel, Unfinished Distressed Knotty Alder.

C. STONE

1. Absolute Black Granite:
 - a. Surround Set: Size Group 1.

D. MISCELLANEOUS:

1. Fasteners: Manufacturer's standard stainless steel or other noncorrosive fasteners.
2. Sealant: Mildew-resistant, single-component, nonsag, neutral-curing silicone joint sealant; ASTM C920, Type S, Grade NS, Class 25, for Use NT.

PART 3 - EXECUTION

3.1 EXAMINATION

- A.** Do not begin installation until substrates have been properly prepared.

B. PREPARATION

1. Clean surfaces thoroughly prior to installation.
2. Prepare surfaces using the methods recommended by the manufacturer for achieving the best results for the substrate under the proper conditions.

C. INSTALLATION

1. Install in accordance with the manufacturer’s instructions, ANSI Z21.44 and the requirements of authorities having jurisdiction.
2. Use manufacturer’s guidelines for minimum clearances to combustible walls and finishes.
3. Anchor all components firmly in position for long life after hard use.

D. FIELD QUALITY CONTROL

1. Upon completion off installation, visually inspect all exposed surfaces. Touch up scratches and abrasions with touch-up paint recommended by the manufacturer, make imperfections invisible to the unaided eye from a distance of 5 feet
2. Test for proper operation, control, and safety devices.

**KOPACHUCK STATE PARK
DAY USE DEVELOPMENT**

E. PROTECTION:

1. Protect installed products until completion of project.

END OF SECTION 103100

**KOPACHUCK STATE PARK
DAY USE DEVELOPMENT**

SECTION 104400 – FIRE PROTECTION SPECIALTIES

PART 1 - GENERAL

1.1 SECTION INCLUDES

- A. Fire extinguishers.
- B. Fire extinguisher cabinets.

1.2 RELATED REQUIREMENTS

- A. 092116 - Gypsum Board Assemblies: Roughed-in wall openings and blocking.

1.3 SUBMITTALS

- A. Product Data: Provide extinguisher operational features, color and finish, and anchorage details.
- B. Shop Drawings: Indicate cabinet physical dimensions, rough-in measurements for recessed cabinets, wall bracket mounted measurements, and location.
- C. Manufacturer's Installation Instructions: Indicate special preparation of substrate, installation and attachment methods, and perimeter conditions requiring special attention.
- D. Maintenance Data: For users operation and maintenance of system including:
 - 1. Test, refill or recharge schedules and re-certification requirements.
 - 2. Methods for maintaining system's materials and finishes.
 - 3. Precautions about cleaning materials and methods that could be detrimental to components, finishes, and performance.

1.4 QUALITY ASSURANCE

- A. Manufacturer Qualification: Company specializing in the manufacture of work specified in this section with minimum 5 years experience.

1.5 DELIVERY, STORAGE, AND HANDLING

- A. As required by the manufacturer for a warrantable installation of the installed products to meet the Performance and Design Criteria.

**KOPACHUCK STATE PARK
DAY USE DEVELOPMENT**

PART 2 - PRODUCTS

2.1 DESCRIPTION

- A. Fire extinguishers, non-rated cabinets, semi- recess mounted with accessories for proper use.

2.2 PERFORMANCE AND DESIGN CRITERIA

- A. Portable fire extinguishers shall be selected and installed in accordance with this section and NFPA 10.

2.3 MATERIALS

- A. Fire Extinguishers and Fire Extinguisher Cabinets:
 - 1. Provide Larsen's Architectural Series Fire Extinguisher Cabinets.
 - a. AL-2409-R7 Full Panel, Clear Acrylic Cabinet
 - b. Buckeye ABC 10lb Tall Fire Extinguisher

PART 3 - EXECUTION

3.1 PREPARATION

- A. Prepare surfaces to receive work in accordance with manufacturer's instructions.

3.2 INSTALLATION

- A. General: Install all materials in accordance with manufacturer's instructions based on conditions present.

3.3 ADJUSTING

- A. Adjust and lubricate hardware for proper operation.

3.4 PROTECTION

- A. Protect installed work as required by the manufacturer to maintain product performance, design criteria and warranty.

END OF SECTION 104400

**KOPACHUCK STATE PARK
DAY USE DEVELOPMENT**

SECTION 105636 - SLATWALL

PART 1 - GENERAL

1.1 SUMMARY

A. Section Includes:

1. Pre-finished slatwall panel system for merchandise displays.

1.2 ACTION SUBMITTALS

A. Product Data: For each type of product.

B. Product Drawings: Manufacturer's drawings showing details and dimensions.

C. Product Samples: For each finish specified, select from manufacturers full arrange of available colors and patterns.

1.3 WARRANTY

1. Warranty Period: One year from date of Substantial Completion.

PART 2 - PRODUCTS

2.1 MANUFACTURER

- A. Slatwall: Display panels shall be manufactured by Marlite; www.marlite.com or approved equal.

2.2 MATERIALS

- A. All pre-finished panels shall be Slatwall slatwall panels.

- B. Shall be constructed utilizing a 48# density medium density fiberboard (MDF) substrate, having an internal bond strength of 110# per square inch minimum. All panels shall have formaldehyde emissions of .3 PPM or less and shall comply with HUD 24 CFR Part 3280 Standards set forth for particleboard panels.

- C. Slatwall panels shall have engineered "T" grooves factory machined:

**KOPACHUCK STATE PARK
DAY USE DEVELOPMENT**

1. 7000 Series: Engineered groove machined into $\frac{3}{4}$ " thick substrate, reinforced with a patented aluminum T-groove insert. Insert finish color to be selected from manufacturer's color options. Inserts are to be factory installed.
- D. Slatwall panels shall have surface (face) finish as follows:
1. Marlite's Finish: A modified melamine enamel that is baked to achieve outstanding performance characteristics.
- E. Slatwall panels shall have grooves machined on 3 inch centers.

PART 3 - EXECUTION

3.1 PREPARATION AND INSTALLATION

- A. All walls to receive Slatwall. Slatwall panels shall be dry, structurally sound, and flat. Install per manufacturer's instructions.

END OF SECTION 105636

**KOPACHUCK STATE PARK
DAY USE DEVELOPMENT**

SECTION 112213- DEPOSITORY SAFE

PART 1 - GENERAL

1.1 SUMMARY

- A. Depository safe to be installed in Welcome Center as indicated on drawings.

1.2 ACTION SUBMITTALS

- A. Product Data: For each type of product.

PART 2 - PRODUCT

2.1 MANUFACTURER/MODEL

- A. Manufacturer: AMSEC
- B. Model: BWB Series, # BWB3020-FL
- C. Interior dimensions: 19”H x 19.75”W x 17” D
- D. Exterior dimensions: 39.75”Hx 20”Wx20”D
- E. Weight: 278 pounds

PART 3 - EXECUTION

3.1 INSTALLATION

- A. General: Install level, plumb, and true

3.2 ADJUSTING AND CLEANING

- A. Test, adjust, and verify operation.

END OF SECTION 112213

**KOPACHUCK STATE PARK
DAY USE DEVELOPMENT**

SECTION 113013 - RESIDENTIAL APPLIANCES

PART 1 - GENERAL

1.1 SUMMARY

A. Section Includes:

1. Kitchen appliances.

1.2 ACTION SUBMITTALS

- A. Product Data: For each type of product.

1.3 CLOSEOUT SUBMITTALS

- A. Operation and maintenance data.

1.4 WARRANTY

- A. Special Warranties: Manufacturer agrees to repair or replace residential appliances or components that fail in materials or workmanship within specified warranty period.

1. Warranty Period: Five years from date of Substantial Completion.

PART 2 - PRODUCTS

2.1 PERFORMANCE REQUIREMENTS

- A. Electrical Appliances: Listed and labeled as defined in NFPA 70, by a qualified testing agency, and marked for intended location and application.

2.2 MICROWAVE

A. Microwave:

1. Basis of Design: Counter Microwave by LG or approved equal.
2. Features:
 - a. Dimensions: 13-9/16 inches (H) x 23-7/8 inches (W) x 19-1/3 inches (D)
 - b. Power Supply: Electric
 - c. Surface Material/Finish: Stainless Steel.

**KOPACHUCK STATE PARK
DAY USE DEVELOPMENT**

- d. Model: LMC2075ST, 2.0 Cu. Ft. Family-Size.

2.3 REFRIGERATOR/FREEZERS

A. Refrigerator/Freezer:

- 1. Basis of Design: Freestanding refrigerator/freezer by LG or approved equal.
- 2. Features:
 - a. Dimensions: 30 inch wide.
 - b. Power Supply: Electric.
 - c. Surface Material/Finish: Stainless Steel.
 - d. Model: LTCS20120S

PART 3 - EXECUTION

3.1 INSTALLATION

- A. Freestanding Equipment: Place units in final locations after finishes have been completed in each area. Verify that clearances are adequate to properly operate equipment.

END OF SECTION 113013

**KOPACHUCK STATE PARK
DAY USE DEVELOPMENT**

SECTION 115213 - PROJECTION SCREENS

PART 1 - GENERAL

1.1 SUMMARY

A. Section Includes:

1. Manually operated, front-projection screens, surfaced mounted.

1.2 ACTION SUBMITTALS

A. Product Data: For each type of product.

B. Shop Drawings: Show layouts and types of front-projection screens. Include the following:

1. Anchorage details.
2. Details of juncture of screen case or trim with adjacent finishes.
3. Accessories.

C. Samples: For each type of exposed finish and for each color and finish specified, in manufacturer's standard sizes.

PART 2 - PRODUCTS

2.1 MANUFACTURERS

A. Acceptable Manufacturer: Draper, Inc. or approved equal.

2.2 MANUALLY OPERATED, SURFACE MOUNTED, FRONT PROJECTION SCREENS

A. Luma 2: Heavy duty, spring roller operated, steel case. Pentagonal, flat back design, steel case with scratch resistant white textured finish. Universal hanging brackets for attachment to wall. Case 22 gauge steel with matching end caps with integral roller brackets.

1. System Options:

- a. Fixed Projected Mounting Brackets with 6 inch clearance from wall. White finish.
- b. Auto Return spring roller with built-in inertia reduction mechanism to ensure viewing surface retracts slowly, smoothly and quietly into case. Provide intermediate stop positions.
- c. Aluminum Operating Pole:
 - 1) 6 feet.

2. Projection Viewing Surface:

**KOPACHUCK STATE PARK
DAY USE DEVELOPMENT**

- a. Matt White XT 1000E: On Axis gain of 1.0. 180 degree viewing cone. Washable surface. GREENGUARD Gold certified.
3. Viewing Area:
 - a. Custom Size: Height: 105 inches ; Width: 140 inches
 - b. Edge Treatment: Black masking borders.
 - c. Mount top of projection screen 12'-6" from floor.

PART 3 - EXECUTION

3.1 INSTALLATION

- A. Install front-projection screens at locations indicated on Drawings to comply with screen manufacturer's written instructions.
- B. Install front-projection screens with screen cases in position and in relation to adjoining construction indicated. Securely anchor them to supporting substrate in a manner that produces a smoothly operating screen that, when lowered, has flat viewing surface and plumb vertical edges.
 1. Test manually operated units to verify that screen-operating components are in optimum functioning condition.

END OF SECTION 115213

**KOPACHUCK STATE PARK
DAY USE DEVELOPMENT**

SECTION 122413 - ROLLER WINDOW SHADES

PART 1 - GENERAL

1.1 SUMMARY

- A. Section Includes:
 - 1. Manually operated roller shades.

1.2 ACTION SUBMITTALS

- A. Product Data: For each type of product.
- B. Shop Drawings: Show fabrication and installation details for roller shades, including shadeband materials, their orientation to rollers, and their seam and batten locations.
- C. Samples: For each exposed product and for each color and texture specified.

1.3 INFORMATIONAL SUBMITTALS

- A. Product certificates.
- B. Product test reports.

1.4 CLOSEOUT SUBMITTALS

- A. Operation and maintenance data.

1.5 QUALITY ASSURANCE

- A. Installer Qualifications: Fabricator of products.

PART 2 - PRODUCTS

2.1 MANUFACTURERS

- A. Window Shade: Basis-of-Design: Subject to compliance with requirements, provide Mecho 5 wide Bracket from MechoShade Systems, Inc. or comparable product by one of the following:
 - 1. Skyco Shading Systems
 - 2. Nysan Solar Control Inc.: Hunter Douglas Company.

**KOPACHUCK STATE PARK
DAY USE DEVELOPMENT**

2.2 WINDOW ROLLER SHADES

- A. Chain-and Clutch Operating Mechanisms: With continuous loop bead chain and clutch that stops shade movement when bead chain is released; permanently adjusted and lubricated.
- B. Rollers: Corrosion-resistant steel or extruded-aluminum tubes of diameters and wall thicknesses required to accommodate operating mechanisms and weights and widths of shadebands indicated without deflection. Provide with permanently lubricated drive-end assemblies and idle-end assemblies designed to facilitate removal of shadebands for service.
 - 1. Roller Drive-End Location: as indicated.
 - 2. Direction of Shadeband Roll: Regular, from back roller.
 - 3. Roller Mounting Configuration: Single roller.
 - 4. Shade to Roller Attachment: Manufacturer's standard method.
- C. Mounting Hardware: Brackets or endcaps, corrosion resistant and compatible with roller assembly, operating mechanism, installation accessories, and mounting location and conditions indicated.
- D. Roller-Coupling Assemblies: Coordinated with operating mechanism and designed to join up to three inline rollers into a multiband shade that is operated by one roller drive-end assembly.
- E. Shadebands:
 - 1. Shadeband Material: EuroVeil Basket Weave 5300 Series (5% open) by MechoSystems.
 - 2. Shadeband Bottom (Hem) Bar: Steel or extruded aluminum.
 - a. Type: Enclosed in sealed pocket of shadeband material.
 - b. Color and Finish: As selected by Architect from manufacturer's full range.

2.3 SHADEBAND MATERIALS

- A. Shadeband Material Flame Resistant Rating: Comply with NFPA 701. Testing by a qualified testing agency. Identify products with appropriate markings of applicable testing agency.

2.4 ROLLER SHADE FABRICATION

- A. Product Safety Standard: Fabricate roller shades to comply with WCMA A 100.1, including requirements for flexible, chain loop devices; lead content of components; and warning labels.
- B. Unit Sizes: Fabricate units in sizes to fill windows.
 - 1. Between (Inside) Jamb Installation: Width equal to jamb-to-jamb dimension of opening in which shade is installed less ¼ inch per side or ½ inch total, plus or minus 1/8 inch. Length equal to head-to-sill.

**KOPACHUCK STATE PARK
DAY USE DEVELOPMENT**

PART 3 - EXECUTION

3.1 EXAMINATION:

- A. Verify that field measurements are as indicated.
- B. Conduct field inspection on an area by area basis during construction to confirm proper mounting conditions per approved shop drawings.

3.2 ROLLER SHADE INSTALLATION

- A. Install roller shades level, plumb, and aligned with adjacent units according to manufacturer's written instructions.
 - 1. Shadebands: Located so shadeband is not closer than 2 inches to interior face of glass. Allow clearances for window operation hardware.
- B. Adjust and balance roller shades to operate smoothly, easily, safely, and free from binding or malfunction throughout entire operational range.
- C. Clean roller shade surfaces, after installation, according to manufacturer's written instructions.
- D. Replace damaged roller shades that cannot be repaired, in a manner approved by Architect, before time of Substantial Completion.

END OF SECTION 122413

**KOPACHUCK STATE PARK
DAY USE DEVELOPMENT**

SECTION 123600 - STAINLESS STEEL COUNTERTOPS

PART 1 - GENERAL

1.1 SUMMARY

A. Section Includes:

1. Delegated design of stainless steel warming kitchen countertop at Day Use Building.

1.2 SUBMITTALS

- A. Delegated Design Submittal: For assemblies indicated to comply with performance requirements and design criteria.
- B. Shop Drawings: Complete details of materials and installation.

1.3 QUALITY ASSURANCE

- A. Fabricator Qualifications: Company specializing in performing the work of this section with a minimum of 5 years experience on projects of similar size and complexity.

PART 2 - PRODUCTS

2.1 MATERIALS

- A. Stainless Steel Countertops at Base Cabinet: Stainless steel,, 16 gauge, Type 304, per ASTM A240 or A666, 2 inch deep raised AV @ edge at counter, non-directional finish. Provide with integral backsplash and sink as indicated on drawings.
- B. Stainless Steel ADA Kitchen Sink and Countertop:
 1. Horizontal countertop panels supported by separate support system and including table legs and back splashes. Integral sinks shall form a continuous part of the worksurface.
 2. Materials:
 - a. Stainless Steel ADA Kitchen Sink and Countertop: Stainless steel shall be Type 304 per ASTM A240 or A666.
 - b. Exposed surfaces shall be a No. 4 satin finish. Stainless steel nuts, screws, bolts, and rivets, etc. shall be of equivalent stainless steel as in the sheet material and shall have a finish closely resembling that of the worksurface.
 - c. Construction:

**KOPACHUCK STATE PARK
DAY USE DEVELOPMENT**

- 1) Stainless steel welding material shall be of type similar to the sheet material or a richer quality. Joints in stainless steel tops shall be welded. Welds shall be made without discoloration and shall be ground, polished, and blended harmoniously with the worksurface finish.
- 2) Worksurface shall be 16 gauge minimum. Stainless steel sides and back splashes shall be integrally welded worksurface top and finished. Edges shall be flanged down. Under surface shall be reinforced with 16 gauge steel channels as required to ensure rigidity and prevent buckling, warping, or oil canning.
- 3) Worksurface shall be pitched to the sink bowl for proper drainage.
- 4) Sink bowls shall be integral within work surface, minimum 16 gauge stainless steel. Sink unit shall be designed and fabricated with sufficient reinforcement to prevent oil canning. Sink joints shall be butt-welded ground smooth, and polished to the same finish as work surface. Inside radii shall be 1 inch. Bottoms shall be pitched to the drain indent. No soldering will be permitted in connection with sink construction.

2.2 ACCESSORIES

- A. Joint Sealant: Mildew-resistant silicone sealant, as selected by Architect from manufacturer's full range.

2.3 FABRICATION

- A. Fabricate tops and splashes in the largest sections practical, with top surface of joints flush.
- B. Provide back/end splash wherever counter edge abuts vertical surface.
 1. Height: 6 inches.

PART 3 - EXECUTION

3.1 INSTALLATION

- A. Assemble countertop and complete work as required by the manufacturer.

3.2 TOLERANCES

- A. Variation from Horizontal: 1/8 inch in 10 feet, maximum.
- B. Offset from Wall, Countertops: 1/8 inch maximum; 1/16 inch minimum.
- C. Field Joints: 1/8 inch wide, maximum.

**KOPACHUCK STATE PARK
DAY USE DEVELOPMENT**

3.3 CLEANING AND PROTECTION

- A. Clean countertops surfaces thoroughly. Protect installed work.

END OF SECTION 123600

**KOPACHUCK STATE PARK
DAY USE DEVELOPEMENT**

SECTION 220500 GENERAL PLUMBING REQUIREMENTS

PART 1 - GENERAL

1.1 WORK INCLUDED

- A. General Plumbing Requirements.
- B. Plumbing Submittals.
- C. Motors.
- D. Equipment and Piping Identification.
- E. Commissioning.

1.2 GENERAL

- A. Includes, but not limited to, furnishing labor, materials, and equipment for completion of work unless indicated or noted otherwise. See Division 1 for sequence of work.
- B. All work included in Division 22 shall be the responsibility of a single Plumbing Subcontractor. This Contractor shall obtain and pay for all permits required by State and local authorities governing the installation of the plumbing work. It is the Contractor's responsibility to contact all utility organizations serving the building, prior to bid, and to include all charges for inspections, installation of materials, equipment, and connection of all required utilities.
- C. The drawings and specifications are complementary and what is called for in either is binding as if called for in both.
- D. All plumbing equipment and devices furnished or installed under other Divisions of this specification (or by the Owner) which require connection to any plumbing systems (i.e., plumbing systems or duct systems, or controls) shall be connected under this division of the Specifications
- E. The Contractor shall be responsible for checking field conditions and verifying all measurements and relationships indicated on the drawings before proceeding with the work.

1.3 ELECTRICAL

- A. All equipment with an electrical connection shall be factory wired to a junction box for connection to electrical service.
- B. Where a piece of equipment specified includes an electric motor, the motor shall be furnished and mounted by this Contractor. Motor starter, disconnect switches and wiring from the electrical panel to the motor control devices and to the motor shall be provided by the Division 26 Contractor unless stated otherwise in the mechanical specification and on the plumbing equipment schedule.

**KOPACHUCK STATE PARK
DAY USE DEVELOPEMENT**

1.4 SYSTEMS DESCRIPTION

A. Site Inspection:

1. Examine premises and understand the conditions which may affect performance of work of this Division before submitting proposals for this work.
2. No subsequent allowance for time or money will be considered for any consequence related to failure to examine site conditions.

B. Drawings:

1. Plumbing drawings show general arrangement of piping, equipment, etc. Follow as closely as actual building construction and work of other trades will permit.
2. Consider electrical drawings part of this work insofar as these drawings furnish information relating to design and construction of building.
3. Because of small scale of plumbing drawings, it is not possible to indicate all offsets, fittings, and accessories which may be required. Investigate structural and finish conditions affecting this work and arrange work accordingly, providing such fittings, valves, and accessories required to meet conditions.

1.5 SUBMITTALS

- A. All material used on the project shall be new and free of defects. The Engineer reserves the right to reject any material, the appearance of which has been damaged on the site or in shipment. The material shall be of approved equal quality to that which is specified. Should the make and type of material differ from that specified, the Contractor may be required to submit catalog and engineering data (samples if requested) necessary to make a comparison and determine its suitability. The Contractor shall also bear the cost of any changes to the plumbing design made necessary by any approved substitutions. Such request for approval shall be made two weeks in advance of the bid opening to allow time to assess its suitability. Failure to obtain approval prior to bid shall require the successful bidder to furnish materials and equipment only as specified herein.
- B. The Contractor shall submit to the Engineer, for approval, complete information on all equipment and materials to be provided on the project including six copies of the manufacturer's catalog and engineering data, shop drawings of shop fabricated equipment and instruction data for each item included under this section of the specifications. Submittals shall be presented to the Engineer within 30 calendar days from the date of the contract signing in complete indexed and bound sets. The Contractor shall submit a typed, signed list including all items to be furnished on the project. The signature on the aforementioned list shall indicate that the contractor has examined the suitability of all material and equipment with respect to compliance with these specifications. The Contractor's approval shall also indicate that physical dimensions of the equipment have been verified with the installation requirements and were found to cause no interference therewith.
- C. Review of submittal data by the Engineer or Engineers does not relieve the Contractor of responsibility for quantities, measurements, and compliance with the intent of all contract documents.
- D. Furnish submittals on all items and equipment specified in Division 22 and all items indicated on plumbing drawings in a hard-back, three-ring binder:

**KOPACHUCK STATE PARK
DAY USE DEVELOPEMENT**

- E. The Contractor shall submit the plumbing cost breakdown including all sub-contractors costs.

1.6 OPERATION AND MAINTENANCE MANUAL FOR PLUMBING SYSTEMS

- A. Bind Operation & Maintenance Manual for Plumbing Systems in three-ring, hard-backed binder with clear plastic pocket on spine. Spine of each binder shall have following typewritten lettering inserted:

OPERATION AND MAINTENANCE MANUAL
FOR PLUMBING SYSTEMS

- B. Provide master index at beginning of Manual showing items included. Use plastic tab indexes for sections of Manual.
- C. First section shall consist of name, address, and phone number of Engineer, General Contractor, and Mechanical, Plumbing, Sheet Metal, Refrigeration, Temperature control, and Electrical subcontractors. Also include complete list of equipment installed with name, address, and phone number of each vendor.
- D. Provide section for each type of item of equipment.
- E. Submit copies of Operation & Maintenance Manual to Engineer for approval.
- F. Include descriptive literature (Manufacturer's catalog data) of each manufactured item. Literature shall show capacities and size of equipment used and be marked indicating each specific item with applicable data underlined.
- G. Operating Instructions shall include:
 - 1. General description of each plumbing system.
 - 2. Step-by-step procedure to follow in putting each piece of plumbing equipment into operation.
- H. Maintenance Instructions shall include:
 - 1. Manufacturer's maintenance instructions for each piece of plumbing equipment installed in Project. Instructions shall include name of vendor, installation instructions, parts numbers and lists operation instructions of equipment, and maintenance and lubrication instruction.
 - 2. Summary list of plumbing equipment requiring lubrication showing name of equipment, location, and type and frequency of lubrication.
 - 3. List of plumbing equipment used indicating name, model, serial number, and nameplate data of each item together with number and name associated with each system item.

1.7 QUALITY ASSURANCE:

- A. Requirements of Regulatory Agencies:
 - 1. Perform work in accordance with applicable Codes.
 - 2. In case of differences between building codes, state laws, local ordinances, utility company regulations, and Contract Documents, the most stringent shall govern.

**KOPACHUCK STATE PARK
DAY USE DEVELOPEMENT**

- B. Product Approvals: See paragraphs elsewhere in this specification.
- C. Manufacture: Use domestic made pipe, pipe fittings, and motors on project.
- D. Identification: Motor and equipment name plates as well as applicable UL and AGA labels shall be in place when project is turned over to Owner.

1.8 CODES AND STANDARDS

- A. Codes and agencies having jurisdictional authority over plumbing installation.

Washington State Energy Code

International Building Code -- Latest Approved Edition

International Mechanical Code -- Latest Approved Edition

Uniform Plumbing Code -- Latest Approved Edition

Local Sewer and Water District Requirements

State and County Department of Health

Occupational Safety and Health Administration (OSHA)

1.9 PRODUCT HANDLING AND PROTECTION:

- A. Contractor is responsible for protection of all material, equipment and apparatus provided under this section from damage, water, corrosion, freezing and dust, both in storage and when installed, until final project acceptance.
- B. Provide temporary heated and sheltered storage facilities for material and equipment.
- C. Completely cover motors and other moving machinery to protect from dirt and water during construction.
- D. Handle and protect equipment and/or material in manner precluding unnecessary fire hazard.
- E. Equipment requiring rotation and/or lubrication during storage shall have records maintained and witnessed on a monthly basis and forwarded to the Engineer prior to acceptance.
- F. Material or equipment damaged because of improper storage or protection will be rejected.
- G. Equipment finish that is damaged by handling, storage, etc. shall be corrected by the Contractor at no additional cost to the Owner.

1.10 WARRANTIES:

- A. In addition to guarantee specified in General Conditions, guarantee plumbing systems to be free from noise in operation that may develop from failure to construct system in accordance with Contract Documents.
- B. In order to be protected, secure proper guarantees from suppliers and subcontractors.

**KOPACHUCK STATE PARK
DAY USE DEVELOPEMENT**

- C. Provide certificates of warranty for each piece of equipment. Clearly record "start-up" date of each piece of equipment on certificate. Include certificates as part of Operation & Maintenance Manual.

1.11 ABBREVIATIONS:

AFF	Above Finish Floor
AMCA	Air Moving & Conditioning Association
ANSI	American National Standards Institute
APWA	American Public Works Association
ARI	Air Conditioning and Refrigeration Institute
ASHRAE	American Society of Heating, Refrigerating and Air Conditioning Engineers
ASME	American Society of Mechanical Engineers
ASTM	American Society of Testing & Materials
AWWA	American Water Works Association
BFF	Below Finish Floor
BHP	Brake Horsepower
BTU	British Thermal Unit
CFC	Chloro - Fluorocarbon
CFM	Cubic Feet per Minute
DOT	US Department of Transportation
EPA	Environmental Protection Agency
fpm	feet per minute
FS or Fed.	Spec. Federal Specifications
HP	Horsepower
IEEE	Institute of Electrical and Electronics Engineers
KW	Kilowatt
MBH	One Thousand British Thermal Units per Hour
MS or Mil.Spec.	Military Specifications
MSS	Manufacturers Standardization Society
NEC	National Electrical Code
NEMA	National Electrical Manufacturers Association
per	in accordance with
PVC	Polyvinyl Chloride
SMACNA	Sheet Metal and Air Conditioning Contractors National Association
SP	Static Pressure

**KOPACHUCK STATE PARK
DAY USE DEVELOPEMENT**

UL	Underwriter's Laboratories
w.g.	Water Gauge (inches of water)
WQA	Water Quality Association

Additional abbreviations are as listed on the drawings or elsewhere in these specifications.

1.12 DEFINITIONS:

- A. Finished Spaces: Spaces used for habitation or occupancy where rough surfaces are plastered, paneled, or otherwise treated to provide a pleasing appearance.
- B. Unfinished Spaces: Spaces used for storage or work areas where appearance is not a factor.
- C. Concealed Spaces: Spaces out of sight. For example, above ceilings; below floors; between double walls; furred-in areas; pipe and duct shafts; and similar spaces.
- D. Exposed: Open to view. For example, pipe running through a room and not covered by other construction.
- E. Outside: Open to view up to 5 feet beyond the exterior side of walls, above the roof, and unexcavated or crawl spaces.
- F. Conditioned Space: An area, room or space normally occupied and being heated or cooled for human habitation by any equipment.

PART 2 - PRODUCTS

2.1 ACCEPTABLE MANUFACTURERS:

- A. Any reference to the specifications or on the drawings to any article, device, product, material, fixture, form or type of construction by manufacturer, name, make, or catalog number shall be interpreted as establishing a standard of quality and shall not be construed as limiting competition.
- B. The manufacturer listed as Acceptable Manufacturers are approved for the items indicated without obtaining prior approval. Other manufacturers require prior approval.
- C. The listing of a manufacturer as an Acceptable Manufacturer does not necessarily mean that the products of that manufacturer are equal to those specified. The listing is only an indication of those manufacturers which may be capable of manufacturing, or have in the past manufactured, items equal to those specified, and is intended to aid the Contractor in identifying manufacturers.
- D. Products provided by Acceptable Manufacturers shall be equal to or superior to the specified manufacturer's item in function, appearance, and quality, and shall fulfill all requirements of the plans and specifications. The Engineer shall be the final judge as to whether an item meets these requirements or not. If a manufacturer is not certain that his product meets these requirements or not, then the manufacturer shall submit data as required to obtain the Design Consultant's approval.

**KOPACHUCK STATE PARK
DAY USE DEVELOPEMENT**

- E. The approval of a manufacturer applies to the manufacturer only and does not relieve the Contractor from the responsibility of meeting all applicable requirements of the plans and specifications.
- F. Contractor shall be responsible for all costs to other trades and all revisions required to accommodate any products which are different than those specified or shown.
- G. In reviewing a manufacturer for acceptance, factors considered include the following: engineering data showing item's performance, proper local representation of manufacturer, likelihood of future manufacturer's local support of product, service availability, previous installation, previous use by Owner/Engineer and record, product quality, availability/quality of maintenance and operation data, capacity/performance compared to specified items, acoustics, items geometry/access utility needs, and similar concerns.
- H. If approval is received to use other than specified items, responsibility for specified capacities and insuring that items to be furnished will fit space available lies with this Division.
- I. If non-specified equipment is used and it will not fit job site conditions, this Division assumes responsibility for replacement with items named in Specification.

2.2 ACCESS DOORS

- A. This contractor shall be responsible for furnishing and installing flush mounted access doors in walls, ceiling and floors and chases where the following equipment is concealed and is not accessible through same.
 - 1. Valves (shut off)
 - 2. Trap Primers
- B. Doors shall be UL listed 16 ga. cold rolled steel with concealed hinge, screwdriver operated lock and prime coated. Furnish suitable for area mounted.
- C. Approved Manufacturers:
 - 1. Milcor
 - 2. Karp
 - 3. Greenheck

2.3 EQUIPMENT AND PIPING IDENTIFICATION

- A. General: All piping, valves, and plumbing equipment shall be marked. All markings in concealed accessible spaces shall be reviewed and verified by Architect/Engineer prior to being concealed.
- B. Piping: Piping shall be marked as follows:
 - 1. Type: Self-sticking colored markers, lettered to identify the pipe contents, and banded at each end with arrow tape indicating the direction of flow. Markers shall be similar and equal to Brady "System 1" and Seton "Opti-Code" markers. Spray painted stencil labeling is not acceptable. Some markers may be special order.

**KOPACHUCK STATE PARK
DAY USE DEVELOPEMENT**

2. Marker Colors and Wording:

Piping System & Wording	Background	Letters
Domestic Cold Water	White	Green
Domestic Hot Water	White	Red

3. Marker Lettering: Lettering shall identify the material conveyed in each pipe. Systems which have supply and return piping shall have piping labeled as such (i.e. domestic hot water etc.). Size of letters and color field shall comply with ANSI A13.1., repeated here for convenience:

Outside Diameter of Pipe or Covering	Length of Color Field	Size of Letters
3/4 to 1-1/4 Inches	8 Inches	1/2 Inches
1-1/2 to 2 Inches	8 Inches	3/4 Inches
2-1/2 to 6 Inches	12 Inches	1-1/4 Inches

4. Locations: Markers shall be installed on all exposed piping adjacent to each shut-off valve, at branches to indicate changes of direction, where pipes pass through walls and floors, on 20 foot centers or at least one in each room on each pipe. Markers shall be installed on all concealed accessible piping (i.e., piping above suspended ceilings, behind access doors, in accessible chases, etc.) near the point of access, except that, for piping above suspended ceilings, markers shall be installed the same as if the piping was exposed (i.e., same as if the suspended ceiling was not in place). Markers shall be installed so as to easily read by a person standing on the floor. Provide additional direction of flow arrows at each pipe connections at all control valves.

C. Valves shall be marked as follows:

1. Identification tags made of brass or aluminum, stamped with valve number and abbreviation of system served (HTG, PLBG, CW, HW, GAS, AC). Tags shall be installed on all valves except stops at plumbing fixtures. Tags shall be not less than 1-1/2 inch in diameter, markings shall be stamped and black filled, and lettering shall be minimum 1/4-inch high with numbers minimum 1/2-inch high. Tags shall be wired to each valve with No. 6 polished nickel-steel jack chain.

- D. All plumbing equipment which was scheduled on the Contract Drawings shall be marked with the name of the item; i.e., Pump No. 1 etc. The identification shall be the same as shown on the Contract Drawings. The marking shall be located on two different sides of the equipment so as to be easily read, with at least one marking visible to a person standing at floor level near the unit (assuming any necessary access to a concealed unit has been made). Lettering shall be a

**KOPACHUCK STATE PARK
DAY USE DEVELOPEMENT**

minimum of 2" high. Marking shall be with engraved phenolic labels, white letters on black background. Equipment marking is not required for; air outlets and inlets, plumbing fixtures.

- E. All mechanical control equipment shall be marked with phenolic labels. Equipment shall be marked to match the tags used in the programming of the control equipment.

PART 3 - EXECUTION

3.1 WORKMANSHIP

- A. This Contractor shall provide completed systems with a neat and finished appearance. If, in the judgment of the Engineer, any portion of the work has not been performed in a workmanlike manner or is left in a rough, unfinished state, this Contractor will be required to remove, reinstall or replace same and patch and paint surrounding surfaces in a manner acceptable to the Engineer, without increase in cost to the Owner.

3.2 CLOSEOUT SUBMITTALS

- A. Requirements: Final approval of plumbing installation will be recommended upon completion of the following:
 - 1. Completion of all punchlist items
 - 2. Operation instruction period to Owner's satisfaction
 - 3. Permit Submittal
 - 4. Valve list posted
 - 5. Reproducible As-Built drawings delivered to Engineer
 - 6. Asbestos Free Statement
 - 7. Guarantees
 - 8. Equipment Manufacturer of all plumbing units shall provide start-up logs.

3.3 FINAL INSPECTION

- A. Final Inspection:
 - 1. Prior to acceptance of the plumbing work, the Contractor shall put all plumbing systems into operation for a period of not less than 5 working days so that they may be inspected by the Engineer and the Owner's representatives.
 - 2. The time of the final inspection shall be mutually agreed to by the Owner, Engineer, and Contractor.
 - 3. The Contractor shall furnish adequate staff to operate the plumbing systems during inspection.

3.4 OPERATION AND MAINTENANCE TRAINING

- A. Upon completion of the work, and after all tests and final inspection of the work by the Authority(s) having jurisdiction, the Contractor shall demonstrate and instruct the Owner's designated operation and maintenance personnel in the operation and maintenance of the various plumbing systems. The Contractor shall arrange scheduled instruction periods with the Owner. The Contractor's representatives shall be Superintendents or Foremen knowledgeable in each system and Supplier's Representative when so specified.

**KOPACHUCK STATE PARK
DAY USE DEVELOPEMENT**

- B. Costs for time involved by Contractor shall be included in the bid.

3.5 PREPARATION

A. Existing Buildings:

1. Cut carefully to minimize necessity for repairs to existing work. Do not cut beams, columns, or trusses.
2. Patch and repair walls, floors, ceilings, and roofs with materials of same quality and appearance as adjacent surfaces unless otherwise shown.
3. This work shall be scheduled such that utility services and/or existing systems for the facility are not interrupted during normal operating hours, without prior written permission of the Owner's representative. Work that is performed during normal operational hours shall not interfere with the normal function of the facility's daily operation.
4. The Plumbing Contractor shall be responsible for the removal of all existing plumbing equipment and utilities indicated to be removed on the drawings. The Plumbing Contractor shall also be responsible for the removal and reinstallation of all existing plumbing equipment and utilities that will interfere with installation and operation of any new construction indicated or required and shall be responsible for the removal of all existing plumbing equipment and utilities indicated to be abandoned that will interfere with installation and operation of any new construction indicated or required. All plumbing equipment (other than piping) to be removed shall remain the property of the Owner, and shall be transported - stored - or disposed of, as directed by the Owner. This will be at no cost to the Owner.
5. The Plumbing Contractor shall provide proof of EPA certified training and EPA registered and tested recovery and recycling equipment with his initial submittals. The Contractor shall evacuate, store, transport, and reclaim all CFC's evacuated from any of the units scheduled for removal to the ARI purity standard.

3.6 INSTALLATION

- A. Install plumbing equipment to permit easy access for normal maintenance, and so that parts requiring periodic replacement or maintenance, (e.g., coils, heat exchanger bundles, sheaves, filters, meters, bearings, etc.) can be removed. Relocate items which interfere with access.
- B. Provide access doors in equipment, ducts, and walls/ceilings as required to allow for inspection and proper maintenance.
- C. If circumstances at a particular location make the accessible installation of an item difficult or inconvenient, the situation shall be discussed with the Engineer before installing the item in a poor access location.
- D. Belts, pulleys, couplings, projecting set screws, keys and other rotating parts which may pose a danger to personnel, shall be fully enclosed or guarded in accordance with OSHA regulations.
- E. Dissimilar Metals: Provide separations between all dissimilar metals. Where not specified in another way, use 10 mil black plastic tape wrapped at point of contact or plastic centering inserts.
- F. Provide offsets around all electrical panels (and similar electrical equipment) to maintain space clear above and below panel to structure and clearance of 3 feet directly in front of panel, except

KOPACHUCK STATE PARK DAY USE DEVELOPEMENT

where indicated otherwise or required by NEC to be more. Such offsets are typically not shown on the drawings, but are required per this paragraph.

- G. Safety Protection: All piping and related items installed by this Contractor that present a safety hazard (i.e., items installed at/near head height, items projecting into maintenance access paths, etc.) shall be covered (at hazardous area) with 3/4" thick elastomeric insulation and 2" wide reflective red/white striped self-sticking safety tape.
- H. Equipment Access: Access to equipment is of utmost importance. Contractor shall apply extra attention to the laying out of pipe routings, and in coordinating all work. Poor access to equipment will not be accepted. Contractor shall note that in essentially all areas, piping routed in ceiling space needs to run in joist space, necessitating elbows/fittings/transitions at crosses with other trades, at structural beams, and at all connections to mains and branches. Dashed areas at HVAC units indicate equipment access areas. These (and all other) access areas shall be clear of obstructions. The Division 22 contractor is responsible to coordinate and insure that all trades stay clear of access areas for any Division 22 furnished equipment.
- I. Insure that items to be furnished fit space available. Make necessary field measurements to ascertain space requirements including those for connections and furnish and install equipment of size and shape so final installation shall suit true intent and meaning of Contract Documents.

3.7 ADJUSTMENT AND CLEANING

- A. Properly lubricate equipment before Owner's acceptance.
- B. Clean exposed piping, equipment, and fixtures, remove debris from site. Repair damaged finishes and leave everything in working order.
- C. All work areas shall be left broom clean and free of debris. Sweep mechanical rooms at completion of work, and dispose of waste. Dispose of all existing waste in mechanical rooms in addition to waste generated by this work.

3.8 COMMISSIONING

- A. The Contractor has specific responsibilities relating to demonstrating the equipment and systems provided have been installed and function per the contract specifications. These responsibilities include, but are not limited to the following:
 - 1. Complete all equipment and system start-up and checkout procedures, and to insure the complete readiness of equipment and systems, prior to the start of the functional performance testing phase of the commissioning process.
 - 2. Functional test all plumbing systems in accordance with the Washington State Energy Code. Demonstrate system performance to the Engineer.
 - 3. Provide to the Owner a written commissioning process and the results of the functional performance testing.
- B. Owner shall not accept equipment and systems, and Owner shall not make final payment, until all equipment and systems have been successfully commissioned and all specified requirements have been satisfied.

END OF SECTION 220500

**KOPACHUCK STATE PARK
DAY USE DEVELOPEMENT**

SECTION 220510 – EXCAVATION AND BACKFILL

PART 1 – GENERAL

1.01 WORK INCLUDED

- A. Excavation and Associated Grading.
- B. Trenching and Trench Protection.
- C. Backfilling and Compaction.
- D. Verification of Existing Utilities.
- E. Protection of Utilities.

1.02 QUALITY ASSURANCE

- A. Inspection of Job Conditions: Prior to starting work and during work, the installer shall examine the work by others, site and job conditions under which excavation, trenching, and backfilling for underground utilities work will be performed, and not proceed with work until unsatisfactory conditions have been corrected in a manner acceptable to the installer.
- B. Codes and Standards: Comply with requirements of the following codes and standards (Latest Edition) except as modified herein:
 - 1. International Building Code.
 - 2. Requirements of local County for all utility work, work in public right of way, and where specified.
 - 3. OSHA and WISHA regulations.

1.03 RESPONSIBILITY

- A. The Contractor is solely responsible for compliance with the requirements of the drawings and specifications local codes and standards, and the proper design, manufacture, delivery, construction coordination with work of other trades, protection and worker's safety. Contractor shall advise Design Consultant of any discrepancy in, or disagreement with the specifications and/or drawings prior to starting work and not proceed until issue is resolved. Only contractors who are fully experienced and entirely knowledgeable shall perform the work specified herein. Commencement of work shall indicate Contractor's acknowledgement of his expertise in this type of work. Any delay resulting from failure to comply with this procedure will not be basis for an extension of the completion date.

1.04 APPLICABLE PUBLICATIONS

- A. The publications listed below form a part of this specification to the extent referenced. The publications are referred to in the text by the basic designation only.
- B. American Society of Testing and Materials (ASTM) publications:
 - D 422-63 Particle Size Analysis of Soils.
 - D 423-66 Liquid Limit of Soils.
 - D 424-59 Plastic Limit and Plasticity Index of soils.

**KOPACHUCK STATE PARK
DAY USE DEVELOPEMENT**

D 1557-78	Moisture Density Relations of Soils using a 10 lb (4.54kg) Rammer and 18 inch (457 mm) Drop.
D 2167-66	Density of Soil In Place by the Rubber Balloon Method.
D 2217-66	Wet preparation of Soil Samples for Particle Size Analysis and Determination of Soil Contents.
D 2487-69	Classification of Soils for Engineering Purposes.
D 2922-81	Test Methods for Density of Soil and Soil Aggregate In Place by Nuclear Methods (Shallow Depth).
E 548-79	Generic Criteria for Use in the Evaluation of Testing and Inspection Agencies.

PART 2 – PRODUCTS

2.01 SATISFACTORY MATERIALS

- A. Materials classified as ASTM D2487, Unified Soil Classification System as SW, SP, GW, and GP are satisfactory for structural fill and for onsite use outside of structural fill areas. Materials classified as SP-SM, GP-GM, GM, GC and ML are also satisfactory for structural fill (excluding structural fill in building areas) provided that they contain moisture contents suitable for the intended use and are reasonably free of organic matter. Native material, not considered unsatisfactory as specified below, may comply. Except that no material shall have any dimension exceeding 2 inches.

2.02 UNSATISFACTORY MATERIALS

- A. Materials classified in ASTM D2487, Unified Soil Classification System as PT, OH, and OL are unsatisfactory. Unsatisfactory materials also include man-made fills, refuse and all materials containing excessive organic matter or having moisture contents which are not suitable for the intended use.

2.03 COHESIONLESS AND COHESIVE MATERIALS

- A. Cohesionless materials shall include materials classified in ASTM D2487 as GW, GP, SW, and SP. Cohesive materials include materials classified as GC, SC, ML CL, MH, and CH. Materials classified as GM and SM will be identified as cohesionless only when the fines are nonplastic. Liquid limit and plasticity index shall be determined in accordance with ASTM D423 using ASTM D2217, PROCEDURE B.

2.04 UNSTABLE MATERIAL

- A. Unstable material shall consist of material too wet to properly support the utility pipe, conduit, or appurtenance structure.

2.05 GRAVELLY SAND BORROW MATERIAL

- A. Gravelly sand borrow material to construct structural fills, provide backfill, or replace unsuitable soil in all building and paving areas shall meet the requirements of SW, SP, GW, and GP materials, except that the maximum percentage passing the No. 200 sieve shall not exceed 5% based on the soil fraction passing the U.S. No. 4 sieve, and not contain discrete particles greater than 6 inches in diameter.

**KOPACHUCK STATE PARK
DAY USE DEVELOPEMENT**

2.06 DEGREE OF COMPACTION

- A. Degree of compaction shall be expressed as a percentage of the maximum density obtained by the test procedure presented in ASTM D1557, Method D. Minimum compaction requirements shall be as specified in PART 3.

2.07 DRAINAGE GRAVEL

- A. Shall be 3/4 inch washed gravel with no more than 2% passing 1/2 inch sieve opening.

2.08 BEDDING

- A. May be either (a) Minus 3/8 inch washed pea gravel, or (b) Gravelly Sand Borrow Material described above passing the 3/4 inch screen with a maximum of 5% passing the No. 200 sieve.

PART 3 – EXECUTION

3.01 EXCAVATION

- A. Excavation of every description and of whatever substances encountered shall be performed to allow the installation of all utilities at the lines and grades indicated; or where not indicated as required. During excavation, material satisfactory for backfilling shall be stockpiled in an orderly manner at a distance from the banks of the trench sufficient to avoid overloading and to prevent slides or cave-ins. Adequate drainage shall be provided for the stockpiles and surrounding areas by means of ditches, dikes, or other approved methods. The stockpiles shall also be protected from contamination with unsatisfactory excavated material or other material that may destroy the quality and fitness of the suitable stockpiled material.
- B. If the Contractor fails to protect the stockpiles and any material becomes unsatisfactory as a result, such material shall be removed and replaced with satisfactory on site or imported material from approved sources at no additional cost to the Owner.
- C. Excavated material not required or not satisfactory for backfill shall be removed from the site and shall be disposed of off site, at the Contractor's expense, at the Contractor's waste area. Any excess satisfactory excavated materials shall not be mixed with unsatisfactory materials. Unsatisfactory materials shall not cover available suitable materials, or be disposed of in such a manner as to interfere with subsequent borrow operations.
- D. Grading shall be done as may be necessary to prevent surface water from flowing into the excavation, and any water accumulating therein shall be removed so that the stability of the bottom and sides of the excavation is maintained. Unauthorized over-excavation shall be backfilled at no additional cost to the Owner.

3.02 TRENCH EXCAVATION

- A. The trench shall be excavated as recommended by the manufacturer of the pipe to be installed. Where recommended trench widths are exceeded, redesign shall be performed by the Contractor using stronger pipe or special installation procedures. The cost of this redesign and the increased pipe or installation procedures shall be borne by the Contractor without additional cost to the Owner.
- B. Bottom Preparation: The bottoms of trenches shall be accurately graded to provide uniform bearing and support for the bottom quadrant of each section of the pipe and for bedding. Bell

**KOPACHUCK STATE PARK
DAY USE DEVELOPEMENT**

holes shall be excavated to the necessary size at each joint or coupling to eliminate point bearing. Stones of 3 inches or greater in any dimension, or as recommended by the pipe manufacturer, whichever is smaller, shall be removed to avoid point bearing.

- C. Removal of Unstable Material: Where unstable material is encountered in the bottom of the trench, such material shall be over-excavated 4" beyond the depth required for proper pipe bedding and replaced to the proper grade with select granular material as provided in paragraph. The Contractor is responsible for all costs associated with removing unstable material and replacing with suitable material. For bidding purposes the Contractor shall assume that 20% of all excavated material is unstable.
- D. Bedding: The bedding surface for the pipe shall provide a firm foundation of uniform density throughout the entire length of the pipe. The pipe shall be bedded carefully in a soil foundation accurately shaped and rounded to conform to the lowest one-fourth of the outside portion of circular pipe or to the lower curved portion of pipe arch for the entire length of pipe or arch. All the bedding shall be tamped into place. Bell holes and depressions for joints shall be only of such length, depth and width as required for properly making the particular type joint. Satisfactory materials may be used for bedding, except as noted in paragraph 3.06 of this section.

3.03 EXCAVATION FOR APPURTENANCES

- A. Excavation for vaults or similar structures shall be sufficient to leave at least 12 inches clear between the outer structure surfaces and the face of the excavation or support members. When concrete or masonry is to be placed in an excavated area, special care shall be taken not to disturb the bottom of the excavation. Excavation to the final grade level shall not be made until just before the concrete or masonry is to be placed.

3.04 JACKING, BORING AND TUNNELING

- A. Unless otherwise indicated, excavation shall be by open cut, except that sections of a trench may be jacked, bored, or tunneled if the pipe, cable or duct can be safely and properly installed and backfill can be properly tamped in such sections.

3.05 BACKFILLING

- A. Backfill material shall be compacted in 6" layers (except initial backfill which shall be 4") and as specified in Paragraph 3.07.
 - 1. Trench Backfill: Trenches shall be backfilled to finish grade. The trench shall be backfilled to above the top of pipe as shown on the drawings prior to performing the required pressure tests. The joints and couplings shall be left uncovered during the pressure test.
 - 2. Replacement of Unstable Material: Unstable material removed from the bottom of the trench or excavation shall be replaced with select granular material or gravel borrow placed in layers not exceeding 6 inches loose thickness.
 - 3. Bedding and Initial Backfill: Bedding shall be of the type and thickness shown on the drawings. Where not indicated, bedding shall consist of satisfactory materials, with no dimension exceeding 2" on any bedding material used. Initial backfill shall be in 4" lift.
 - 4. Backfill for Appurtenances: After the manhole, catch basin, inlet, or similar structure has been constructed and the concrete has been allowed to cure for the days specified, backfill shall be placed in such a manner that the structure will not be damaged by the shock of falling earth. The backfill material shall be deposited and compacted as

**KOPACHUCK STATE PARK
DAY USE DEVELOPEMENT**

specified for final backfill, and shall be placed in such a manner as to prevent eccentric loading and excessive stress on the structure. Compaction shall be as specified.

3.06 SPECIAL REQUIREMENTS

- A. Special requirements for both excavation and backfill relating to the specific utilities are as follows:
 - 1. Fire Lines: Trenches shall be of a depth to provide a minimum cover of 3.5 feet (or deeper if required by local authority) from the existing ground surface, or from the indicated finished grade, whichever is lower, to the top of the pipe. Bedding shall use satisfactory materials as specified.
 - 2. Domestic Water Lines: Trenches shall be of a depth to provide a minimum cover of 3.5 feet (or deeper if required by local authority) from the existing ground surface, or from the indicated finished grade, whichever is lower, to the top of the pipe. Except that branch lines serving individual fixtures within building footprint shall have minimum of 1.0 foot cover. Bedding shall use satisfactory materials as specified.

3.07 COMPACTION

- A. Each layer of fill, or the excavated subgrade, shall be compacted to at least 95 percent, per ASTM D1557, of laboratory maximum density. Compaction shall be accomplished by approved tamping rollers, pneumatic-tired rollers, three-wheel power rollers, or other approved compaction equipment. Areas requiring structural fill to four feet below footings not accomplished under the previous contract, shall be compacted to 90% of maximum density, per ASTM D1557.

3.08 PROTECTION

- A. Newly graded excavated or bedded areas shall be protected from traffic and from erosion, and any settlement or washing away that may occur from any cause, prior to acceptance, shall be repaired and grades reestablished to the required elevations and slopes.
- B. Verify location of existing utilities prior to beginning work. Utilize Owner as-builts, field electronic detection equipment, visual site surveys, and careful exploratory digging at key locations. Protect all existing utilities from damage.

END OF SECTION 220510

**KOPACHUCK STATE PARK
DAY USE DEVELOPEMENT**

SECTION 220519 – PIPING SPECIALITIES

PART 1 - GENERAL

1.1 WORK INCLUDED

- A. Thermometers
- B. Pressure Gauges
- C. Strainers
- D. Unions
- E. Flexible Connectors

PART 2 - PRODUCTS

2.1 APPROVED MANUFACTURERS

- A. Flexible Connectors: Flexonics, Metraflex, Resistoflex, Universal

2.2 THERMOMETERS

- A. Adjustable angle type, with brass stem, separable brass sockets, 7-inch scale, aluminum case, red reading mercury, white face with black numerals, and markings in degrees F. Provide sockets with extension necks where installed on insulated piping.
- B. Thermometer Temperature Ranges:

<u>Measuring</u>	<u>Range Degrees F</u>	<u>Increments Degrees F</u>
Domestic Cold Water	0 - 100	1
Domestic Hot Water	30 - 180	2

2.3 PRESSURE GAUGES

- A. Pressure Gauges: 4-1/2-inch dial (except natural gas gauges which shall have 2-1/2 inch dial), stem mounting, aluminum or stainless steel case, white face with black numerals, phosphor bronze bourdon tube, 1/4-inch NPT bottom connection. Provide a shut-off cock for all gauges, coil siphon for all steam gauges, and snubber on all liquid line gauges.
- B. Pressure Gauge Ranges:

<u>Measuring</u>	<u>Range PSIG</u>	<u>Intervals PSIG</u>	<u>Inter-Graduations</u>
Heating Hot Water	0 - 200	20	2
Chilled Water	0 - 120	20	2

**KOPACHUCK STATE PARK
DAY USE DEVELOPEMENT**

2.4 STRAINERS

- A. Water Strainers: "Y" type, same size as the pipe in which they are installed, with cast iron or semi-steel bodies rated for 125 psi working pressure, and with removable cover and sediment basket. Basket screen shall be stainless steel or monel, with a net free area of at least 3 times that of the entering pipe. Provide with blowdown valve where shown on the drawings.

2.5 UNIONS

- A. Dielectric Unions: Rated at 250 psi at 180 deg. F., conforming to ANSI B16.39. Type and size to match piping.
- B. Unions on Copper Pipe:
 - 1. In 2-Inch Pipe and Smaller: Wrought copper solder joint copper to copper union.
 - 2. In 2-1/2-Inch Pipe and Larger: Brass flange unions.

2.6 FLEXIBLE CONNECTORS

- A. Double Bellows Type: Steel Flanges, Nylon reinforced neoprene body, Kinetics model KinFlex or approved.

PART 3 - EXECUTION

3.1 INSTALLATION

- A. Unions: Install unions in pipe connections to control valves, coils, regulators, reducers, all equipment, and where it may be necessary to disconnect the equipment or piping for repairs or maintenance; and as indicated.
- B. Dielectric Unions: Install dielectric unions at all connections between dissimilar piping materials.

END OF SECTION 220519

**KOPACHUCK STATE PARK
DAY USE DEVELOPEMENT**

SECTION 220520 – PIPE AND PIPE FITTINGS

PART 1 - GENERAL

1.1 WORK INCLUDED

- A. Pipe.
- B. Pipe Fittings.
- C. Pipe Joining and Connections.

1.2 SUBMITTALS

- A. Shall comply with Section 220500 - General Plumbing Requirements.
- B. Product submittals are required for all pipe and pipe fittings to be used on this project.

1.3 GENERAL REQUIREMENTS

- A. Application: See each individual system specification sections for call-out of piping materials to be used for that system.

1.4 REFERENCES

- A. ANSI/ASTM A53: Pipe, Steel, Black and Hot Dipped Zinc Coated, Welded and Seamless.
- B. ANSI/ASTM A120: Pipe, Steel, Black and Hot-Dipped Zinc Coated (Galvanized), Welded and Seamless for Ordinary Uses.
- C. ANSI B16.4: Cast Iron Threaded Fittings
- D. ANSI B16.3: Malleable Iron Threaded Fittings
- E. ANSI B16.9: Steel Butt-Welding Fittings
- F. ANSI B16.11: Steel Socket - Welding Fittings.
- G. ANSI B16.5: American 150, 300, 400, 600, 900, 1,500, and 2,500 Pound Steel Flange Standards.
- H. ANSI/ASTM B88: Seamless Copper Water Tube.
- I. ANSI/ASTM B32: Solder Metal.
- J. ANSI B16.22: Wrought Copper and Bronze Solder Joint Pressure Fittings.
- K. ANSI B16.18: Cast Bronze Solder Joint Pressure Fittings.
- L. ANSI B16.24: Cast Copper and Bronze Flange Fittings.
- M. CISPI 301: Cast Iron Soil Pipe and Fittings for Hubless Cast Iron Sanitary System.
- N. ASTM 564: Rubber Gaskets for Cast Iron Soil Pipe and Fittings.
- O. CISPI 310: Cast Iron Soil Pipe Couplings for Hubless Cast.
- P. ANSI/ASTM D3212: Joints for Drain and Sewer Plastic Pipes Using Flexible Elastomeric Seals.

**KOPACHUCK STATE PARK
DAY USE DEVELOPEMENT**

- Q. ANSI/ASTM F477: Elastomeric Seals (Gaskets) for Joining Plastic Pipe.

PART 2 - PRODUCTS

2.1 ACCEPTABLE MANUFACTURERS

- A. Products shall comply with Section 220500 - General Plumbing Requirements, Acceptable Manufacturers.
- B. Steel Pipe and Fittings: U.S. Steel, Bethlehem, Walworth, Flagg, Grinnell, Felker.
- C. Copper Pipe and Fittings: Mueller, Nibco, Flagg, Elkhart.
- D. Plastic Pipe and Fittings: Tyler, Chemtrol, Western Plastics, Spears, GPK.
- E. Miscellaneous Fittings/Materials: As called out in individual specifications.

2.2 COPPER PIPE AND FITTINGS

- A. Pipe: Seamless copper tubing, type K, L, or M as indicated, per ANSI/ASTM B88.
- B. Fittings: Soldered joints with 95-5 tin-antimony solder per ANSI/ASTM B32 or "Silvabrite 100" (95.5 tin/4 copper/0.5 silver) solder. Solder shall be lead-free. Wrought copper fittings per ANSI B16.22, cast bronze fittings per ANSI B16.18, cast flange fittings 150 lb per ANSI B16.24. Underground joints shall be brazed, with BCuP-4, BCuP-5, or BA9-1 filler metals (per American Welding Society Standards).
- C. Refrigerant Pipe and Fittings: Piping shall be ACR Type L copper tubing, with silver brazed joints using filler metals per American Welding Society Standards, and wrought copper fittings.

2.3 PLASTIC PIPE AND FITTINGS

- A. Pipe and Fittings: Pipe and fittings shall be manufactured from PVC compound with a cell class of 12454 per ASTM D 1784 and conform with National Sanitation Foundation (NSF) standard 14. Pipe shall be iron pipe size (IPS) conforming to ASTM D 1785 and ASTM D 2665. Injection molded fittings shall conform to ASTM D 2665. Fabricated fittings shall conform to ASTM F 1866.
- B. All pipe and fittings to be produced by a single manufacturer and to be installed in accordance with manufacturer's recommendations and local code requirements. Never test with or transport/store compressed air or gas in PVC pipe or fittings. Solvent cements shall conform to ASTM D 2564. Primer shall conform to ASTM F 656. The system to be intended for non-pressure drainage applications where the temperature will not exceed 140°F.

2.4 ABS DRAIN, WASTE, AND VENT PIPE AND FITTINGS

- A. Pipe and Fittings: Inside and outside layers of pipe shall be manufactured from ABS compound with a minimum cell class of 42222 per ASTM D 3965. Center layer of pipe shall be manufactured from PVC compound with a cell class of 11432 per ASTM D 4396. Pipe shall be iron pipe size (IPS) Schedule 40 conforming to ASTM F 1488.

**KOPACHUCK STATE PARK
DAY USE DEVELOPEMENT**

- B. Fittings shall be manufactured from ABS compound with a cell class of 32222 per ASTM D 3965. Fittings shall conform to ASTM D 2661. Both pipe and fittings shall conform to NSF International Standard 14.
- C. All pipe and fittings to be produced by a single manufacturer and to be installed in accordance with manufacturer's recommendations and applicable code requirements. Never test with or transport/store compressed air or gas in ABS pipe or fittings. Buried pipe shall be installed in accordance with ASTM D 2321 and ASTM F 1668. Solvent cement shall conform to ASTM D 2235. The system is to be intended for non-pressure drainage applications where the temperature will not exceed 140°F

PART 3 - EXECUTION

3.1 PIPE INSTALLATION – GENERAL

- A. All piping in finished areas shall be installed concealed unless specifically noted otherwise.
- B. Install piping at such heights and in such a manner so as not to obstruct any portion of windows, doorways, or passageways.
- C. Coordinate installation of piping with all trades which are affected by installation to avoid conflicts.
- D. Offset or reroute piping as required to clear any interferences which may occur.
- E. Consult all drawings for location of pipe spaces, ducts, electrical equipment, ceiling heights, door openings, window openings, and other details and report discrepancies or possible conflicts to Architect/Engineer before installing pipe.
- F. Allow sufficient clearances for installation of pipe insulation in thickness specified. If interferences occur, reroute piping to accommodate insulation.
- G. Pitch all piping and provide drain valves so that all piping and equipment can be drained.
- H. Provide escutcheons where pipe passes through walls, floors, or ceilings.
- I. Install all exposed piping parallel to the closest wall and in a neat, workmanlike manner.
- J. Do not run any piping above electrical panels (and similar electrical equipment). Provide offsets around such panels as necessary.

3.2 PIPE JOINING

- A. General: Prior to the joining of any section of pipe to a pipe run, the section shall be thoroughly cleaned inside and out, and the ends shall be reamed to remove any cutting burrs.
- B. Threaded Connections: Cut piping carefully, ream, thread and work into place without springing. Use teflon tape or lead and graphite lubricant--on male threads only.
- C. Soldered Connections: Polish contact surfaces of fittings and pipes with emery cloth before fluxing male and female surfaces of joints. Steel wool and sandpaper not permitted for polishing.

**KOPACHUCK STATE PARK
DAY USE DEVELOPEMENT**

- D. Unions: Install unions in pipe connections to valves, coils, and any other equipment where it may be necessary to disconnect the equipment or piping for repairs or maintenance; and as indicated. Where flanged connections occur at equipment additional unions are not required unless indicated otherwise.
- E. Insulating Unions: Install dielectric insulating unions or insulating type flexible connectors between all connections of copper piping and steel piping or steel equipment. Where flanged connections occur use insulating type flanges.

END OF SECTION 220520

**KOPACHUCK STATE PARK
DAY USE DEVELOPEMENT**

SECTION 220529 – PIPING HANGERS AND SUPPORTS

PART 1 - GENERAL

1.1 WORK INCLUDED

- A. Pipe Hangers
- B. Equipment Hangers

1.2 QUALITY ASSURANCE

- A. Pipe Hanger Standards: (MSS) Manufacturers Standardization Society Standards SP-58-1975, SP-89-1978, and SP-69-1976.
- B. All methods, materials and workmanship shall conform to the International Building Code (IBC) and Uniform Mechanical Code (UMC), as amended and adopted by the authority having jurisdiction.

1.3 SUBMITTALS

- A. Submittals shall comply with Section 220500 – General Plumbing Requirements.
- B. Submit product data. Indicate where such items are to be used.
- C. Shop drawings are required for all equipment supports and fabricated supports or assemblies.

PART 2 - PRODUCTS

2.1 ACCEPTABLE MANUFACTURERS

- A. Hangers and Supports: Elcen, Grinnell, B-Line Systems, Unistrut, Michigan, Tolco.
- B. Anchors: Rawplug, Phillips, Hilti, Michigan.

2.2 GENERAL HANGERS AND SUPPORTS

- A. Hanger Rods: Threaded hot rolled steel, electro-galvanized or cadmium plated. Hanger rods shall be sized so that the total load (including pipe or duct, insulation, hangers, and fluid) does not exceed the following:

<u>Nominal Rod Diameter</u>	<u>Maximum Load</u>
1/4 Inch	240 Pounds
5/16 Inch	440 Pounds
3/8 Inch	610 Pounds
1/2 Inch	1130 Pounds

**KOPACHUCK STATE PARK
DAY USE DEVELOPEMENT**

- B. Hanger Straps: Galvanized steel. Straps shall be sized so that the total load does not exceed the following:

<u>Strap Size</u>	<u>Maximum Load</u>
1" x 22 Gauge	230 Pounds
1" x 20 Gauge	290 Pounds
1" x 18 Gauge	380 Pounds
1" x 16 Gauge	630 Pounds

- C. Beam Attachments: Shall be of the following type:

<u>MSS Type</u>	<u>Elcen Figure No.</u>	<u>Grinnell Figure No.</u>
21	33,34	131
22	67	66
23	29A	87
28	95	292,228
30	95	229

- D. Steel: Structural steel per ASTM A36.

- E. Wood: Shall be fire treated.

2.3 PIPE HANGERS AND SUPPORTS

- A. All hangers used directly on copper pipe shall be copper plated or have a factory applied 1/16-inch thick (minimum) plastic coating on all contact surfaces.
- B. All other hangers, supports, and hardware shall be cadmium plated or galvanized.
- C. Pipe Hangers and Supports: Shall be of the following type (numbers are 'MSS'):

<u>Maximum System Temperature</u>	<u>Insulated Pipe Type</u>
120 to 450 Degrees	1, 3, 7, 9, 10, 41, 42, 43, 44, 45, 46, E
60 to 120 Degrees	1, 3, 7, 9, 10
33 to 59 Degrees	1, 3, 5, 7, 9, 10, 41, 42, 43, 44, 45, 46, E

- D. Vertical Pipe Supports: MSS Type 8 riser clamp (elcen Fig. 39 and 339; Grinnell Fig. 261 and 261C).

- E. Trapeze Hangers: Shall be constructed of carbon steel angles, channels or other structural shapes with flat surface for point of support. Trapeze hangers shall be supported with hanger rods suspended from concrete inserts or approved structural clips. Provide a steel washer plate (Elcen Fig. 84 or equal) where hanger rod nuts bear on trapeze hanger.

- F. Insulated Pipe Supports:

**KOPACHUCK STATE PARK
DAY USE DEVELOPEMENT**

1. Insulation material at pipe support shall consist of expanded perlite insert with flame resistant jacket of nylon reinforced kraft paper bonded to aluminum foil cover on insulation, with sheet metal shield. Expanded perlite shall have no more than 5% deformation at 100 psi and a thermal conductivity no more than 0.32 Btu/hr./sq. ft./degree F/1-inch thick.
2. Expanded perlite insert shall be same thickness as adjoining pipe insulation, sized to match pipe used on.
3. Minimum insulation, shield lengths, and shield gauge:

<u>Normal Pipe Diameter In Inches</u>	<u>Insulation Length In Inches</u>	<u>Shield Length In Inches</u>	<u>Minimum Shield Gauge</u>
1/2 to 2	6	3	20
2-1/2 to 3-1/2	6	4	18
4 to 5	9	6	18
6 to 10	9	6	16

4. Manufacturer: Michigan Hanger Company, Model Nos. 1031 and 4031.

PART 3 - EXECUTION

3.1 INSTALLATION – GENERAL

- A. Provide all necessary bolts, nuts, washers, turnbuckles, rod connectors and any other miscellaneous accessories required for the support and anchoring of all pipes, ducts, and mechanical equipment.
- B. Install steel or wood backing in walls (anchored to studs) as required to provide support for items hung from walls. Backing shall be of the same material as the studs or structure they are attached to.
- C. All welded steel support assemblies shall have a power wire brush and primer paint finish.
- D. Attach to building structure as shown on drawings.
- E. Maximum spans between piping supports may be significantly less than the maximum spans allowed herein due to structural limitations of allowable loads on hangers. The most restrictive criteria governs. Reference structural drawings.

3.2 INSTALLATION OF PIPE HANGERS AND SUPPORTS

- A. Pipe which is not run underground shall be adequately anchored to the structure to prevent sagging and to keep pipe in alignment.
- B. All pipe supports shall be provided with a means of adjustment for the aligning and leveling of the pipe after installation.
- C. Installation and sizing of pipe supports and accessories shall be in accordance with the manufacturer’s recommendations and standard MSS SP-89 and MSS SP-69, UPC, and UMC.
- D. Provide supports at each change in direction of piping.

**KOPACHUCK STATE PARK
DAY USE DEVELOPEMENT**

- E. Where mechanically coupled piping is used, a hanger shall be placed within 2 feet on each side of couplings, with hanger spacing in no case to exceed the following:

<u>Normal Pipe Diameter</u>	<u>Maximum Span Mechanically Coupled Piping</u>
3/4 to 1 Inch	7 Feet
1-1/4 to 1-1/2 Inch	7 Feet
2 Inches	10 Feet
2-1/2 Inches	10 Feet
3 Inches and Larger	12 Feet

NOTE: Manufacturer's support instructions shall be used where it is more restrictive than the above. Above is for rigid coupled piping systems. Follow manufacturer's requirements for flexible piping systems, except that in no case is spacing to be less than the above.

- F. Copper Tubing: Maximum spacing between supports:

<u>Nominal Tubing Diameter</u>	<u>Maximum Span Copper</u>
1/2 to 1 Inch	5 Feet
1-1/4 to 1-1/2 Inch	6 Feet
2 to 2-1/2 Inch	8 Feet
3 Inches and Larger	10 Feet

- G. Three or more pipes running parallel may be supported on trapeze hangers provided the slopes of such pipes allow use of common trapeze. Where trapeze width exceeds 24 inches, provide three (3) hanger rod supports.
- H. Provide additional supports at concentrated loads (such as valves, in-line pumps, etc.) on each side of the load. Such supports are in addition to the ones otherwise required.
- I. Vertical Piping Supports: Support piping at each floor line with pipe clamps and at intermediate points as required to prevent excessive pipe movement and so as to comply with the maximum spacings cited above. Support all pipe stacks at their bases with a concrete pier or suitable hanger. For vertical pipe drops which occur away from a wall or similar anchoring surface, provide angled bracing from nearest structure to provide rigid anchoring of pipe drop.
- J. Pre-Insulated Pipe Supports: Protect all insulated pipe at point of support with pre-insulated pipe supports. Such supports shall be in place at time of installing pipe.

END OF SECTION 220529

**KOPACHUCK STATE PARK
DAY USE DEVELOPEMENT**

SECTION 220530 – SLEEVES AND SEALS

PART 1 - GENERAL

1.1 WORK INCLUDED

- A. Pipe Sleeves
- B. Seals

1.2 REFERENCES

- A. ASTM E814: Fire Tests of Through-Penetration Fire Stops
- B. UL 1479: Through-Penetration Fire Stop Systems.

PART 2 - PRODUCTS

2.1 ACCEPTABLE MANUFACTURERS

- A. Products shall comply with Section 220500 – General Plumbing Requirements, Acceptable Manufacturers.
- B. Fire Seals: 3M, Down Corning, General Electric, Rectorseal.

2.2 PIPE SLEEVES

- A. Size: Inside diameter of pipe sleeves shall be at least 1/2-inch larger than the outside diameter of the pipe or pipe covering, as to allow free movement of piping.
- B. Ends: Sleeve ends shall be cut flush with finished surfaces, except in rooms having floor drains where sleeves shall be extended 3/4-inch above finished floor.
- C. Material - Structural: Sleeves through structural elements shall be fabricated from Schedule 40 steel pipe.
- D. Material - Non-structural: Sleeves through non-structural elements shall be fabricated from 18 gauge galvanized sheet metal or 24 gauge spiral duct.

2.3 SEALS

- A. Seals at exterior of building: Provide a sleeve through exterior walls sealed to the wall system per architectural plans. Core drilled penetrations in concrete do not require a sleeve. Provide modular mechanical seal between the sleeve and penetrating pipe. Eaton Link-Seal or approved.
- B. Seals In Other Areas: Packed fiberglass or wool insulation, where no weatherproofing or adhesive properties are required; otherwise, sealants shall be silicone type, as specified in applicable Division 7 Specification Section.

**KOPACHUCK STATE PARK
DAY USE DEVELOPEMENT**

PART 3 - EXECUTION

3.1 INSTALLATION OF PIPE SLEEVES

- A. Provide pipe sleeves for all piping passing through walls, floors, partitions, roofs, foundations, footings, grade beams, and similar elements, except that sleeves are not required for penetrations through existing single solid elements, having no voids, at the location where the piping passes through the solid elements (e.g., solid wood stud, core drilled solid concrete, etc.). Where a sleeve is required, such sleeve shall continue all the way through any solid items within that element however.
- B. Set sleeves plumb or level (or sloped as required for drainage pipe) in proper position, tightly fitted into the work.
- C. Fill openings around outside of pipe sleeve with same material as surrounding construction, or with material of equivalent fire and smoke rating.
- D. Seal around all pipes inside of pipe sleeve.
- E. Insulation shall run continuous through sleeves in non-fire rated elements. Insulation shall not run continuous through sleeves in fire rated elements unless the fire sealant system used is UL accepted for use with insulated pipes.

3.2 INSTALLATION OF SEALS

- A. Provide seals around all piping and ducts passing through walls, floors, roofs, foundations, footings, grade beams, partitions, and similar elements.
- B. Pipe penetrations through the building envelope shall be sealed water tight.

END OF SECTION 220530

**KOPACHUCK STATE PARK
DAY USE DEVELOPEMENT**

SECTION 220548 – PIPING VIBRATION AND SEISMIC CONTROL

PART 1 - GENERAL

1.1 WORK INCLUDED

- A. Vibration Isolators
- B. Seismic Restraints

PART 2 - PRODUCTS

2.1 NEOPRENE ISOLATORS

- A. Suspension Isolators: Shall be double deflection neoprene type, with isolator encased in open steel bracket and minimum 3/8-inch deflection. Hanger rod shall be isolated from steel bracket with neoprene grommets. Mason Series HD, Amber Booth "BRD" or approved.

2.2 SPRING ISOLATORS

- A. General: The load carried by each isolator shall be carefully calculated and isolators selected so that the static deflection will be the same and the supported equipment will remain level. Isolators shall be so designed that the ends of the springs will remain parallel during and after deflection to operating height. At operating height, springs shall have additional travel to complete (solid) compression equal to at least 50 percent of the operating deflection. Suspension isolator springs shall have a static deflection (as shown on drawings) not less than 1-1/2", except that for units with components rotating at 1000 rpm and less, the static deflection shall be not less than 2 inches. Floor isolator springs shall have deflection of not less than 1 inch. All isolators shall provide at least 96% isolation efficiency. Note: Deflections other than these may be used where circumstances warrant and more optimum isolation results can be achieved.
- B. Suspension Type Spring Isolators: Shall consist of a rigid steel frame, a stable steel spring in the bottom part of the frame, and double deflection neoprene isolating pad at the top of the frame. Where supporting rods pass through the frame, a clearance of not less than on half rod diameter shall be provided all around the rod. Mason Series DNHS, Amber Booth "BSSR" or approved.

2.3 SEISMIC RESTRAINTS

- A. Materials: Steel shall be per STM A36; hangers and other devices shall be as shown in SMACNA Seismic Restraint Manual Guidelines for Mechanical Systems latest edition. Sheet metal used for bracing shall be no less than 16 gauge. Cable bracing may be used provided that opposed acting cables are provided on the items being braced to provide bracing equal to that provided by rigid angle bracing.

**KOPACHUCK STATE PARK
DAY USE DEVELOPEMENT**

PART 3 - EXECUTION

3.1 INSTALLATION

A. Vibration Isolation:

1. Motorized equipment shall be suspended from spring vibration isolators either integral or external to the equipment.
2. Unless otherwise indicated, resilient mounts for motorized equipment shall be of the type and size to provide maximum ten percent transmissibility. Use unhoused, free-standing stable steel springs which are preferred over housed spring assemblies. The horizontal stiffness of the spring shall be approximately equal to its vertical stiffness. The Spring deflection shall be selected based on the equipment power range (HP), speed range (RPM), and static deflection of the supporting structural floor. For large equipment such as fans the steel spring static deflection of the supporting structural floor. It is a specific recommendation that whenever a steel spring is used, two pads of ribbed waffle-pattern neoprene be used in series with the spring.
3. The design of vibration dampening shall consider lateral load as well as vertical load and be suitably snubbed against earthquake forces.
4. A list of isolators accompanied by certified transmissibility ratings for the required duty shall be submitted for each item of equipment.
5. Unless noted otherwise, all vibration isolating equipment shall be of the same make and shall be submitted as one group.
6. Special equipment, such as compressors shall be selected on an individual basis.

3.2 SEISMIC CONTROL

- A. Provide earthquake snubbers for all equipment that is supported on spring isolators and weighing over 300 lbs. including base. Provide minimum of four snubbers for equipment weighing less than 2,000 lbs., and eight snubbers for heavier equipment.
- B. Pipes of all sizes that are suspended on hangers that are longer than 12" shall have a transverse brace every 40 ft and a longitudinal brace every 80 ft.

END OF SECTION 220548

**KOPACHUCK STATE PARK
DAY USE DEVELOPEMENT**

SECTION 220700 – PIPING INSULATION

PART 1 - GENERAL

1.1 WORK INCLUDED

- A. Duct Insulation.
- B. Pipe Insulation.
- C. Equipment and Specialties Insulation.

1.2 DEFINITIONS

- A. "Run-out" means "piping not more than 12 feet long that runs to an individual fixture or unit."
- B. "Conditioned Areas" means "areas that are directly and intentionally supplied by heated or cooled air".

1.3 QUALITY ASSURANCE

- A. All insulation shall have a fire hazard rating not to exceed 25 for flame spread and 50 for smoke development, as tested by ASTM E-84, NFPA 255, and UL-723.

1.4 SUBMITTALS

- A. All submittals shall comply with Section 220500 – General Plumbing Requirements.
- B. Provide product data on all insulation materials to be used. Indicate thicknesses to be used.

1.5 GENERAL REQUIREMENTS

- A. Code Compliance: Contractor shall insulate all systems with the materials and thicknesses as specified herein, but in no case shall the insulation be less than that required by the Washington State Energy Code (latest edition and amendments) or Energy Code enforced by the authority having jurisdiction. Contractor shall, in addition to insulating those systems/items specified herein, provide insulation where required by Code.
- B. Insulation at Hangers: Insulation shall be continuous through hangers on all insulated systems (except ductwork.) Inserts at hangers are specified and are considered as part of the hanger and support system. Inserts are required to be installed at the time of pipe installation and are intended to be installed by the Contractor installing the pine hangers/supports.

**KOPACHUCK STATE PARK
DAY USE DEVELOPEMENT**

PART 2 - PRODUCTS

2.1 ACCEPTABLE MANUFACTURERS

- A. Products shall comply with Section 220500 - General Plumbing Requirements, Acceptable Manufacturers.
- B. Insulation: Manville, Armstrong, Owens-Corning, CSG, Knauf, Rubatex, Pittsburgh Corning, Imcoa, Halstead.
- C. Accessories: Same as for insulation and Duro Dyne, Gustin Bacon, Childers, RPR, Tee Cee, J. P. Stevens, Buckaroos, Johnson.

2.2 PIPE INSULATION

- A. Fiberglass Insulation: Rigid fiberglass insulation, thermal conductivity shall not exceed 0.24 Btu-inch/hr-sq. ft.-degrees F. at 75 degrees F with jacket consisting of high density white kraft bonded to aluminum foil, with pressure sensitive closure system, integral vapor barrier with 0.02 perm rating.
- B. Elastomeric Insulation: Density not less than 5 lbs per cubic foot and thermal conductivity not greater than 0.27 Btu-inch/hr-ft-degrees F. Armstrong "Armaflex" or equal.
- C. Foamglas Insulation: Glass cell insulation, Pittsburgh Corning "Foamglas," with thermal conductivity no less than 0.35 Btu-in/hr-sq. ft.-degrees F at 75 degrees F, compressive strength of 100 psi, and water-vapor permeability of 0.00 perm-inch as tested per ASTM and "pittwrap" water-proof membrane.
- D. Pipe Fittings (except unions and expansion couplings): Shall be covered using any one of the following methods of the Contractor's choice:
 - 1. Prefabricated segments of pipe insulation of same materials and thickness as the adjoining pipe insulation, formed to match pipe fitting.
 - 2. Pre-cut fiberglass insulation and pre-molded PVC covers suitable for the pipe size and insulation thickness encountered. PVC cover shall be equal to Manville "Zeston."
 - 3. Insulating plastic cement brought up the full height of the adjacent covering.
- E. Metal Jacket: Aluminum roll jacketing, with smooth surface, manufactured from 1100, 3003, 3105 or 5005 aluminum alloy conforming to ASTM B-209. Shall be minimum 0.016 inches thick, with an integrally bonded interior moisture barrier over the entire surface in contact with the insulation.
- F. P-traps and HW/CW Lines on Handicap Lavatories: Prefabricated insulation specially designed for p-trap application, with white elastomeric insulation, white high gloss PVC cover, and snap together closure. Provide section for insulating HW stop, CW stop, and leads of same material. TRU BRO "LAV GUARD" or equal.

**KOPACHUCK STATE PARK
DAY USE DEVELOPEMENT**

G. Insulation Thickness and Types:

1. Domestic Hot Water:

a. Aboveground:

<u>Pipe Size</u>	<u>Fiberglass Insulation Thickness</u>
Run outs Up to 2 Inches	0.5 Inch
2 Inches and Less	1.0 Inch
2.5 Inches to 4 Inches	2.0 Inch

2. Domestic Cold Water: 1/2 inch thick fiberglass insulation.

3. Refrigerant Suction Piping:

a. 1 inch thick elastomeric insulation for pipe sizes 1 inch and less; 1.5 inch thick elastomeric for larger pipe sizes.

4. Condensate Drain Piping (within the building): 1/2 inch thick fiberglass or elastomeric insulation.

5. Outdoor Piping: Piping exposed to outside air shall have insulation thickness increased by 0.5 inch from that indicated above. Elastomeric insulation may be used in lieu of fiberglass, provided the insulation is manufacturer approved for applications proposed.

6. Alternative Insulation Thickness: Insulation thickness indicated is based on the thermal conductivities specified. Contractor at his option may use other insulation thicknesses for insulation with different thermal conductivities provided that the overall heat transfer coefficient is the same as if the specified insulation had been used. Submit calculations showing insulation equivalency for approval.

2.3 EQUIPMENT AND SPECIALTIES INSULATION

A. Equipment: Insulation shall be same material as that specified for the piping system the equipment is installed in. Insulation thickness shall be 1.5 inches.

B. Valves: All valves installed in insulated piping systems shall be insulated. Insulation material and thickness shall be same as that specified for the pipe system the valve is installed in. Insulation shall be removable type on all control valves.

C. Removable Insulation: Shall provide thermal insulating properties equivalent to that which is provided for piping system. Shall consist of 0.25-inch J. P. Stevens "Insulbatte" with glass cloth jacket, 4.0-inch Owens-Corning thermal insulating wool, Type II, fastened with No. 304 stainless steel hooks tied with 0.040-inch soft solid annealed copper wire. Where metal jacketing is required, provide with removable enclosures, of same material as metal jacketing, configured to suit items covered.

PART 3 - EXECUTION

3.1 GENERAL

A. Equipment and Floor Protection: Cover existing equipment and finished floors to protect such items from insulation fiber and dust. Keep all such existing areas in a "broom clean" condition at

KOPACHUCK STATE PARK DAY USE DEVELOPEMENT

the end of each day. Take precautions in these areas to prevent glass fiber and insulation dust from entering existing ventilating systems.

- B. Glass Fiber Insulation:
 - 1. Finish all insulation ends, no raw edges allowed.
 - 2. Joints: Tightly butt adjacent insulation sections together without any voids. Provide overlap of jacket material over all circumferential joints.
- C. Insulation Thickness: See "Part 2 - Products" for insulation thicknesses.
- D. Items To Be Insulated: Provide insulation on all piping, and all items installed in the piping systems, all energy conveying, all energy storage, and all energy consuming devices specified as part of Division 22, except where such insulation has been specifically excluded.
- E. Items Excluded From Being Insulated:
 - 1. Electric motors.
 - 2. Factory insulated water heaters (except for base).
 - 3. Fire sprinkler piping.
 - 4. Stops and risers at plumbing fixtures (Except ADA Lavatories).

3.2 PIPE INSULATION INSTALLATION

- A. All ends shall be firmly butted together and secured with butt strips of a minimum 3 inch wide. On hot piping, all jacket laps and butt strips shall be secured with outward clinch staples at 4 inch spacing, or by use of a suitable lap adhesive.
- B. All piping shall be insulated except where specifically excluded.
- C. Elastomeric Pipe Insulation: Shall be completely sealed to provide a vapor proof barrier.
- D. Pipe Hangers: Provide insulation tight up to pre-insulated pipe supports at pipe hangers.
- E. Pipe Sleeves: For insulated pipe, do not run insulation through sleeve, except where fire sealant system used is UL approved for use with insulated pipes, then install insulation in full sized thickness completely through the pipe sleeve.
- F. No pipe covering materials shall be applied until the pipe runs to be covered have been tested by the Contractor and reviewed by the Architect-Engineer, and no covered sections of pipe shall be buried or concealed in the structure until said insulation and covering work has been reviewed.
- G. Handicap Lavatories: Insulate P-trap and HW supplies below lavatory where exposed.
- H. Items in piping that require access (i.e. flow measurement devices) shall have removable insulation provided.
- I. Provide metal jacket over piping insulation for all outside exposed piping.

3.3 EQUIPMENT AND SPECIALTIES INSTALLATION

- A. All equipment where access is required shall have insulation installed so that it can be easily removed and reinstalled without requiring new insulation. Items requiring such removable insulation include, but are not limited to, the following:
 - 1. Control Valves.
 - 2. Strainers.
 - 3. Balancing Devices.

**KOPACHUCK STATE PARK
DAY USE DEVELOPEMENT**

4. Pressure/Temperature/Flow Measuring Devices.
- B. Specialties Requiring Insulation: All items connected in an insulated piping system shall be insulated, except the following:
1. Factory Insulated Items.
 2. Water Meters.
 3. Hose Bibbs.
 4. Relief Valves.

END OF SECTION 220700

**KOPACHUCK STATE PARK
DAY USE DEVELOPEMENT**

SECTION 221100 – DOMESTIC WATER PIPING

PART 1 - GENERAL

1.1 WORK INCLUDED

- A. Domestic Water Piping.
- B. Valves.
- C. Water Hammer Arrestors and Air Chambers.
- D. Trap Primers.
- E. Backflow Preventers.
- F. Water Service Connections.
- G. Testing and Inspection.
- H. Sterilization.

1.2 SUBMITTALS

- A. Submittals shall comply with Section 220500 – General Plumbing Requirements.
- B. Submit product information on all items to be used.

1.3 REFERENCES

- A. AWWA B300, Hypochlorites.
- B. AWWA B301, Liquid Chlorine.
- C. AWWA M20, Water Chlorination Principles and Practices.

1.4 GENERAL REQUIREMENTS

- A. Solder: Only lead-free solder shall be used on potable water systems.
- B. All work and products shall comply with the governing codes (reference Section 220500 – General Plumbing Requirements).

PART 2 - PRODUCTS

2.1 ACCEPTABLE MANUFACTURERS

- A. Products shall comply with Section 220500 – General Plumbing Requirements, Acceptable Manufacturers.
- B. Valves: Crane, Grinnell, Nibco, Stockham, Walworth, Milwaukee, Kitz, Red-White, Watts.
- C. Trap Primers: JR. Smith, Precision Plumbing Products.

**KOPACHUCK STATE PARK
DAY USE DEVELOPEMENT**

- D. Backflow Preventers: Febco, Watts, Ames.
- E. Additional manufacturers are as listed for each individual item.

2.2 PIPE AND FITTINGS

- A. Pipe and fitting standards shall be as specified in Section 220520, Pipe and Pipe Fittings.
- B. Domestic Water Piping Located Above Ground: Type L copper tubing with solder joints and wrought copper or cast brass fittings.
- C. Domestic Water Piping Located Below Ground: Type K copper tubing with silver brazed joints and wrought copper or cast brass fittings.
- D. Trap Primer Piping: Type L or K "soft" or "hard" (bending temper) copper, with compression fittings or soldered joints.

2.3 VALVES

- A. Gate Valves:
 - 1. 3 Inches and Larger: 125 psi-swp iron body gate, bronze mounted, bolted bonnet, OS&Y, flanged. Stockham No. G-623.
- B. Globe Valves:
 - 1. 2-1/2 Inches and Smaller: 125 psi-swp bronze globe, threaded bonnet, teflon or bronze disc, solder or threaded connection. Stockham No. B-13T, B-14T, B-16, B-17.
 - 2. 3 Inches and Larger: 125 psi-swp iron body globe, bronze mounted, bronze or teflon disc, flanged. Stockham No. G-512, G-514T.
- C. Ball Valves:
 - 1. 2-1/2 Inches and Smaller: 125 psi-swp bronze ball, standard port, 2 piece construction, anti-blowout stem, teflon seats, stainless steel or chrome plate ball, extended stem, memory stop, solder or threaded connections as required. Nibco S580, T580.
- D. Check Valves: Class 125 bronze check valve, horizontal swing, regrinding type, Y-pattern, renewable discs, complying with MSS SP-80.
- E. Pressure Relief Valves: ASME rated pressure relief valve, set for pressure indicated or as required to protect system from over pressure. Valve shall have minimum 400,000 BTU/HR relief capability and no smaller than 3/4-inch connection sizes.
- F. Buried Site Isolation Valves: 200 psi nonshock water working pressure, iron body, bronze mounted, non-rising stem type, open counterclockwise, with "o-ring" type packing, standard 2-inch operating nut, complying with ANSI/AWWA C500. Furnish with operating wrench, length to suit installation.

2.4 SPECIALTIES

- A. Water Hammer Arrestors: All metal, factory precharged with inert gas, sealed internal bellows; 125 psi working pressure. All wetted parts shall be type 300 stainless steel, brass or copper. Zurn "Shoktrol", Wade "Shokstop", J. R. Smith "Hydrotrol", or Josam equivalent; in P.D.I. (Plumbing and Drainage Institute) sizes as indicated.

**KOPACHUCK STATE PARK
DAY USE DEVELOPEMENT**

B. Trap Primer Valve:

1. For Single Drains: Cast bronze trap primer valve, 1/2-inch connections, for serving single floor drain. J.R. Smith No. 2699 or approved.
2. For Single and Multiple Drains: Manufactured of corrosion resistant copper and brass, with valve and line pressure adjustment with manifold for serving multiple drains. Primer valve activated by drop-in water pressure. Precision Plumbing Products "Prime Rite" or approved.
3. Valve Box: Cast iron box, rated for H₂O loading, adjustable type with flanged top section and flared base. Style to suit valve used with and depth, and as acceptable to local code officials. Valve box cover shall be cast with words "WATER".

2.5 BACKFLOW PREVENTERS

- A. Reduced Pressure Type: Washington State approved, with air gap drain and resilient seated full flow shutoff valves and test cocks. Size [and capacity] as shown on drawings. Febco Models 825Y, 825 or approved.
- B. Double Check Type: Washington State approved, with resilient seated full flow shutoff valves and test cocks. Size [and capacity] as shown on the drawings. Febco Model 805, 805Y or approved.

2.6 DOMESTIC WATER DIAPHRAGM TANK

- A. Diaphragm type thermal expansion absorber. Amtrol or approved.
- B. Construction: Welded steel construction, with rigid polypropylene liner, butyl diaphragm, air charging valve, and ASME certified.
- C. Capacity: 2.0 gallon tank volume (minimum).

PART 3 - EXECUTION

3.1 INSTALLATION OF PIPING AND FITTINGS

- A. Installation and joining of all piping shall comply with Section 220520 - Pipe and Pipe Fittings.
- B. Provide all non-potable water, domestic hot water, and cold water piping as indicated and as required to allow supply connections to each fixture and equipment item requiring water supply.
- C. Run all piping concealed unless piping is specifically noted as to be run exposed.
- D. Provide supply connections to equipment furnished by others in accordance with Section 220500 - General Plumbing Requirements.
- E. Install all piping sloped to low points to allow the system to be drained.

3.2 INSTALLATION OF VALVES

- A. For Valves 2-Inch and Smaller: Provide ball valves unless drawings indicate globe valves.
- B. Provide isolation valves as shown on the drawings. In addition to those shown, provide added valves to allow for the isolation of each group of fixtures and all individual equipment items.

**KOPACHUCK STATE PARK
DAY USE DEVELOPEMENT**

- C. Install valves as to be easily accessible and oriented to permit ease of operation. Valve stem shall be directed toward operator in either the vertical or horizontal direction. Provide access doors or panels to valves built into construction.
- D. Provide pressure reducing valves as shown on drawings, complete with by-pass line, isolation valves, unions, and pressure gauges. Set initial pressure as shown, and adjust as required so that all fixtures/devices served have sufficient water pressure.
- E. Provide drain valves at the base of all risers.
- F. Provide drain valves at piping low points where the piping cannot be drained through fixtures or hose bibbs.
- G. Provide balancing valves in hot water circulation piping where indicated and where required to allow for equal distribution of hot water circulation flows.
- H. Butterfly valves installed at equipment or other system components which may be disconnected from the system shall be lug type suitable for dead end service. This includes butterfly valves at water heaters, pressure reducing valves, and similar equipment.

3.3 INSTALLATION OF SPECIALTIES

- A. Water Hammer Arrestors: Install per manufacturer's instructions. Provide ball isolation valve in piping to arrestor. Where access cannot be provided at water line location, extend water hammer arrestor piping and locate above ceiling outside of plumbing chase. Provide ceiling access doors as required. Provide water hammer arrestors at each flush valve or at the end of a bank of flush valves. Size water hammer arrestors per P.D.I.
- B. Trap Primers: Provide trap primers to all vented floor drains and where required by the governing code. Install as shown on drawings and provide with a isolation valve in the branch line to the trap primer valve.
- C. Access Covers and Doors: Provide access to all valves, water hammer arrestors, trap primers, backflow preventers, and any other piping accessories which would otherwise be inaccessible.
- D. Provide backflow preventers of type, and in locations, as shown on the drawings.
- E. Backflow devices shall be installed, inspected, and tested in accordance with the applicable portions of the Washington Administrative Code and other applicable regulations as set forth by the Washington State Department of Social and Health Services.
- F. Install heat tracing as shown on drawings and in accordance with manufacturer's instructions and NEC requirements.

3.4 WATER SERVICE CONNECTIONS

- A. Provide connection to water main outside the building as shown on the drawings.
- B. Provide sleeve in floor for entrance of service main into building, seal watertight; anchor service main firmly to building floor and walls. Seals shall comply with Section 220530 - Sleeves and Seals.

3.5 TESTING AND INSPECTION

- A. All piping shall be tested, inspected, and approved (by the local authority having jurisdiction) prior to being concealed or covered.

**KOPACHUCK STATE PARK
DAY USE DEVELOPEMENT**

- B. Testing shall be witnessed by the plumbing inspector and the Architect/Engineer. Notify Architect/Engineer 48 hours prior to date of testing.
- C. Piping shall be hydrostatically tested for a period of 2 hours, during which time no drop in pressure or leakage shall occur.
- D. Test pressure shall be not less than 150 percent of the maximum to which the pipe will ordinarily be subjected; but in no case less than 150 psig.
- E. Any leaks or defective piping disclosed by testing and inspection shall be repaired with new materials and the system re-tested.

3.6 FLUSHING AND DISINFECTION

- A. System Flushing: After tests are completed, all water piping shall be flushed. In general, sufficient water shall be used to produce a minimum water velocity of 2.5 feet per second through piping being flushed. Flushing shall be continued until discharge water shows no discoloration. System shall be drained at low points. Strainer screens shall be removed, cleaned, and replaced in line. System valves and fixture faucets shall be opened and re-closed to completely flush system. After flushing and cleaning, systems shall be prepared for disinfection service by immediately filling water piping with clean, fresh potable water. Any stoppage, discoloration, or other damage to the finish, furnishings, or parts of the building, due to the Contractor's failure to properly clean the piping system, shall be repaired by the Contractor.
- B. Adjust the hot water circulation system for uniform circulation throughout the system.
- C. Upon completion of the job and prior to final acceptance, the plumbing system shall be disinfected with Chlorine solution. Review procedures and disinfection with the authority having jurisdiction to insure that all work complies with code requirements. Verify any deviations from specified procedures with the Engineer prior to proceeding. The chlorinating material shall be either liquid chlorine conforming to AWWA B301 or hypochlorite conforming to AWWA B300 (or as otherwise required by the authority having jurisdiction). Water chlorination procedure shall be in accordance with AWWA M20 (or procedure acceptable to authority having jurisdiction). The chlorinating material shall provide a dosage of not less than 50 parts per million and shall be introduced into the system in an approved manner. The treated water shall be retained in the pipe long enough to destroy all non-spore-forming bacteria.
- D. The retention time shall be at least 24 hours and shall produce not less than 10 ppm of chlorine at the extreme end of the system at the end of the retention period. All valves in the system being sterilized shall be opened and closed several times during the contact period. The system shall then be flushed with clean water until the residual chlorine is reduced to less than 1.0 ppm. During the flushing period all valves and faucets shall be opened and closed several times.
- E. The Contractor shall employ an approved agency to take test samples at several points of the system in properly sterilized containers and arrange with the Health Department having jurisdiction to test the samples. Should the samples not test satisfactory, the system shall be re-sterilized and re-flushed until satisfactory samples are obtained.
- F. The Contractor shall furnish a letter to the Engineer stating that Chlorination has been completed. The letter shall also include a copy of a certificate from the Health Department having jurisdiction stating that samples taken have been found acceptable.

END OF SECTION 221100

**KOPACHUCK STATE PARK
DAY USE DEVELOPEMENT**

SECTION 221123 – PUMPS

PART 1 - GENERAL

1.1 WORK INCLUDED

- A. Domestic Circulators.

1.2 SUBMITTALS

- A. All submittals shall comply with Section 220500 – General Plumbing Requirements.
- B. Provide product information and performance data for all pumps.
- C. Performance data shall include pump curves, showing pump performance as head vs. GPM, BHP and NPSH vs. GPM, with system operating point clearly marked. (NPSH vs. GPM not required for pumps 1 HP and less.)

PART 2 - PRODUCTS

2.1 ACCEPTABLE MANUFACTURERS

- A. Products shall comply with Section 220500 – General Plumbing Requirements.
- B. Domestic Circulators: Bell & Gossett, Grundfos, Armstrong.

2.2 GENERAL

- A. All rotating parts shall have been statically and dynamically balanced at the factory.
- B. Pumps shall operate at 1750 rpm unless indicated otherwise.
- C. Pump Capacity: Shall be no less than the values listed on the Mechanical Equipment Schedule on the drawings.
- D. Pump Types: The type of each pump is indicated on the Mechanical Equipment Schedule under the "Type" column, and corresponds to the types specified herein.
- E. Motors: Shall comply with Section 220500 – General Plumbing Requirements. Motors shall be of sufficient size so as to be non-overloading at any point on the operating curve and shall be no smaller than the size shown on the drawings. Motors shall be of drip-proof construction, unless indicated otherwise shall be 1750 rpm (unless indicated otherwise), resilient mounted with oil lubricated journal or ball bearings, and have built-in thermal overload protectors. Motors shall be for use with the voltage and phase as scheduled on the drawings.
- F. Controls: Furnish each pump with motor starter and overload protectors unless indicated otherwise.
- G. Bronze: Pumps used on domestic water systems shall be of all-bronze construction.
- H. Testing: All pumps shall be factory tested and thoroughly cleaned.

**KOPACHUCK STATE PARK
DAY USE DEVELOPEMENT**

- I. Finish: Pumps shall have minimum one coat high grade machinery enamel finish, factory applied, manufacturer's standard color.

2.3 DOMESTIC CIRCULATORS

- A. Pumps shall be of the in-line, horizontal system lubricated type specifically designed and guaranteed for quiet operation.
- B. Pump to be suitable for 230°F operation at 150 psig maximum working pressure.
- C. The pumps shall have a ceramic shaft supported by carbon bearings. Bearings are to be lubricated by the circulating fluid.
- D. Pumps to have a capacity of 5 GPM at 5 foot head when powered by 115 volt, 60 cycle single phase electrical supply.
- E. Pump body shall be lead-free bronze for NBF circulators or stainless steel for SSF circulators. Motor stator to be isolated from circulating fluid through use of stainless steel can. Rotor to be sheathed in stainless steel.

PART 3 - EXECUTION

3.1 INSTALLATION

- A. Install pumps at locations shown on the drawings.
- B. Decrease from line size to pump inlet size with long radius reducing elbows and minimum 5-pipe diameter straight pipe into pump (except where suction diffusers are used). Where reducers (in the horizontal) are used on pumps, they shall be the eccentric type installed with taper on the bottom.
- C. Check motor alignment after pump installation, realign as necessary.
- D. Check pump operation to ensure that specified flows are provided, without motor unloading or pump cavitation. Notify the Architect/Engineer of any unusual conditions or performance other than as specified.

END OF SECTION 221123

**KOPACHUCK STATE PARK
DAY USE DEVELOPEMENT**

SECTION 221300 – SOIL WASTE AND VENT PIPING

PART 1 - GENERAL

1.1 WORK INCLUDED

- A. Soil, Waste and Vent Piping.
- B. Condensate, Overflow, Miscellaneous Drains.
- C. Cleanouts.
- D. Vent Flashing.
- E. Testing and Inspection.

1.2 SUBMITTALS

- A. Submittals shall comply with Section 220500 - General Plumbing Requirements.
- B. Submit product information on all items to be used.

PART 2 - PRODUCTS

2.1 ACCEPTABLE MANUFACTURERS

- A. Products shall comply with Section 220500 - General Plumbing Requirements, Acceptable Manufacturers.
- B. Cleanouts: Josam, Zurn, J. R. Smith, Wade.

2.2 PIPE AND FITTINGS

- A. Pipe and fitting standards shall be as specified in Section 220520 - Pipe and Pipe Fittings.
- B. Waste Piping: As specified in section 220520 - Pipe and Pipe Fittings.
- C. Acid Waste and Vent Piping: As specified in Section 220520 - Pipe and Pipe Fittings.
- D. Condensate Drains:
 - 1. Copper DWV or type M copper with soldered joints.

2.3 CLEANOUTS

- A. General:
 - 1. All cleanouts shall have cast iron bodies with bronze countersunk rectangular slotted plugs, lubricated with a non-hardening teflon base thread lubricant and having a gasket seal.
 - 2. Cleanouts located in waterproof membrane floors shall be provided with an integral cast flange and flashing device.

**KOPACHUCK STATE PARK
DAY USE DEVELOPEMENT**

3. All cleanouts shall be the same size as the pipe which they are intended to serve (but not larger than 4-inch).
4. Pipe fittings for cleanouts which turn through walls or up through floors shall use long sweep ells or a "Y" and 1/8 bend.
5. All cleanouts and access covers shall be provided with vandal proof screws.
6. Cleanouts in carpeted areas shall have cleanout marker.

B. Floor Cleanouts:

1. Areas with Floor Tile (or Linoleum): J. R. Smith No. 4140 Series adjustable floor level cleanout with round heavy duty nickel bronze top with tile recess.
2. Areas With Bare Concrete Floors: J. R. Smith No. 4100 Series stable floor level cleanout with round heavy duty nickel bronze top.
3. Areas With Terrazzo (and Similar Poured Floors): J. R. Smith No. 4180 Series adjustable floor level cleanout with round heavy duty nickel bronze top with terrazzo recess.
4. Areas With Carpet: J. R. Smith 4020-X Series adjustable floor level cleanout with round heavy duty nickel bronze top and carpet clamp.

C. Wall Cleanouts: Cast iron ferrule with cast bronze taper threaded plug, with plug tapped 1/4-inch, 20 thread, to accept access cover screw; with access cover. Access cover shall be stainless steel or chrome plated in "wet" areas (kitchen, lockers, restrooms) and prime painted steel elsewhere.

D. Outside Cleanouts: Heavy duty, round, cast iron, double-flanged housing, having scoriated cast iron cover with lifting device, ferrule and bronze closure plug. Housing and lid shall be galvanized and have vandal resistant screws. J. R. Smith No. 4251 or 4256 Series.

PART 3 - EXECUTION

3.1 INSTALLATION OF PIPE AND FITTINGS

- A. Installation and joining of all piping shall comply with Section 220520 - Pipe and Pipe Fittings.
- B. Provide all soil, waste and vent piping as indicated and as required to allow waste and vent connections to each fixture and equipment item requiring connection.
- C. The work of this section shall include all sanitary sewer lines inside of the building and 5-feet outside of the building (unless indicated otherwise), to the point of and including connections to outside sanitary sewer lines or sanitary sewer manholes.
- D. The installation of all piping shall be in compliance with the Governing Codes.
- E. Install all horizontal soil or waste lines with a slope of 1/4-inch per foot. Exceptions require written approval of the Administrative Authority.
- F. Make all changes of direction and junctions with Y fittings and 1/8 bends; use sanitary tee fittings in vertical pipe only.
- G. Consult manufacturer's data and architectural drawings for information on plumbing fixtures before beginning rough-in.
- H. Verify points of connection, invert elevations, and grade requirements before beginning installation.

**KOPACHUCK STATE PARK
DAY USE DEVELOPEMENT**

- I. Coordinate installation of piping with all trades affected by installation.
- J. Stub all piping for all items requiring connection through wall or floor; cap and protect until connection to items is complete.
- K. Vents extending through roof shall terminate at least 10 inches above roofing; and not less than 10 feet from and 3 feet above any building opening.
- L. Vent Flashing: Provide vent flashing at each vent through roof; 4 lb. sheet lead, extending 10-inches all around pipe with sleeve to top of vent; counterflashing to overlap 2-inch and turn down inside the pipe (or similar water-proof methods as required to best suit roofing material/manufacturer).
- M. Connect equipment furnished by others in accord with Section 220500 – Pipe and Pipe Fittings.
- N. Trap all fixtures and equipment items as required by governing code; provide proper venting for each trap.
- O. All excavation, trenching and backfilling shall comply with Section 220510 - Excavation and Backfill.
- P. Provide drain piping for all drip pans, unit condensate drains, unit P-traps, etc. Run piping to nearest point of drainage, or as shown on drawings. Where routing is not shown, route to nearest point of proper drainage.

3.2 INSTALLATION OF CLEANOUTS

- A. Install cleanouts in all soil and waste piping:
 - 1. At no more than 100 foot intervals on horizontal runs;
 - 2. At the end of all piping runs;
 - 3. At the base of all vertical risers.
 - 4. At all changes of direction for a run of 10 feet or over;
 - 5. At all locations shown on the drawings and where needed to correct possible stoppage and as required by governing code.
- B. Where cleanouts occur in concealed spaces provided extensions to floors above or to walls to allow access.
- C. Provide wall access covers for all wall cleanouts. See Section 220700 - Piping Insulation for specification of wall access covers.
- D. Floor cleanouts shall be installed so as to be flush with the finished floor; where recessed cleanout covers are used the recess shall be filled flush with material to match the surrounding finished floor.
- E. Install cleanouts so as to assure proper clearances as required by governing code.
- F. All cleanouts located outside shall be provided with an access housing located in a 24" x 24" x 6" thick concrete pad, flush with the adjacent finished grade. The pipe and cleanout shall be independent of this access housing and pad.

**KOPACHUCK STATE PARK
DAY USE DEVELOPEMENT**

3.3 TESTING AND INSPECTION

- A. All piping shall be tested, inspected and approved prior to being concealed or covered.
- B. Testing shall be by water or air, and shall comply with governing code.
- C. Testing shall be witnessed by the plumbing inspector and the Engineer's representative.
- D. Water Testing:
 - 1. Fill system with water so that there is no less than 10 feet of head above the highest system section being tested.
 - 2. System shall hold pressure for a period of at least 15 minutes with no leakage before the inspection starts.
 - 3. The system shall be inspected and shall hold tight with no leakage at all points.
- E. Air Testing:
 - 1. Pressurize system with air so that there is no less than 5 psig of air pressure in the system.
 - 2. System shall hold pressure for a period of at least 15 minutes without the introduction of additional air before the inspection starts.
 - 3. The system shall be inspected and shall hold tight with no leakage at all points.
- F. All leaks shall be eliminated and the system re-tested before proceeding with work or concealing pipe.
- G. All repairs to piping shall be with new material and no caulking of screwed joints or holes is allowed.

END OF SECTION 221300

KOPACHUCK STATE PARK
DAY USE DEVELOPEMENT

SECTION 224000 – PLUMBING FIXTURES AND TRIM

PART 1 – GENERAL

1.1 WORK INCLUDED

- A. Plumbing Fixtures and Trim.
- B. Water Heaters.
- C. Adjustment and Cleaning.

1.2 DEFINITIONS

- A. "Plumbing Brass" means "P-traps, stops, strainers, tailpieces, flanges, and other brass fittings and accessories NOT including faucets or stops."
- B. "Trim" includes all plumbing brass items, faucets, and any fixture accessories.

1.3 REFERENCES

- A. Uniform Plumbing Code.

1.4 SUBMITTALS

- A. All submittals shall comply with Section 220500 – General Plumbing Requirements.
- B. Submit product data for all plumbing fixtures, plumbing trim, and water heaters.
- C. Submit shop drawing of flue and flashing; showing support and flashing details.

1.5 GENERAL REQUIREMENTS

- A. Provide new fixtures and fittings, approved, free from flaws and blemishes with finished surfaces clear, smooth and bright. Visible parts of fixture brass and accessories, and all items located in accessible cabinet spaces, shall be heavily chrome plated. All stops risers, P-traps shall be chrome plated.
- B. All products and connections shall comply with the Governing Code, the local Health Department, and Public Utilities Department.

PART 2 – PRODUCTS

2.1 ACCEPTABLE MANUFACTURERS

- A. Products shall comply with Section 220500 – General Plumbing Requirements, Acceptable Manufacturers.
- B. Vitreous china and enameled cast iron fixtures: American Standard; Eljer; Kohler; Crane.

KOPACHUCK STATE PARK
DAY USE DEVELOPEMENT

- C. Water Closet Seats: Church; Beneke; Olsonite; Kohler; Bemis.
- D. Carriers: Josam; J. R. Smith; Wade; Zurn; Watts Drainage.
- E. Stainless Steel Sinks: Elkay, Just.
- F. Hydrants and Hose Bibbs: Zurn; Woodford; Wade; J.R. Smith.
- G. Floor Drains: J. R. Smith; Wade; Zurn; Watts Drainage.
- H. Water Heaters: Rheem, A.O. Smith.
- I. Plumbing Brass: American Standard; Brasscraft; Chicago Faucet; Crane; Eljer; Frost; Kohler; Speakman; Symmons; T & S Brass; McGuire; Elkay; Eastman.
- J. Faucets: Chicago Faucet; T & S Brass.
- K. Flush Valves: Sloan Royal (NO SUBSTITUTIONS).
- L. Drinking Fountains: Elkay, Halsey Taylor.

2.2 PLUMBING FIXTURES

A. General:

1. Plumbing Fixtures are listed below by reference numbers, corresponding to the reference number adjoining these items on the drawings.
2. All vitreous china and enameled cast iron fixtures shall be finished white unless specifically noted otherwise.
3. All stainless steel sinks shall be sound deadened, and shall have faucet ledge (except where noted specifically without ledge).
4. In interests of Owner's Standardization, fixtures of similar type shall be product of one manufacturer; trim of similar type shall be product of one manufacturer.

B. Water Closets:

1. P-1A Water Closet - Wall Hung - Handicap:

Water Closet: Kohler "Kingston-Lite", No. K-4330, vitreous china, elongated bowl, wall mounted, siphon jet action bowl with 1-1/2" top spud, and 1.6 gallon flush. Wall mounted for handicap access. Verify with Architectural drawings for mounting heights and off-center stall dimensions.

Flush Valve: Sloan "Royal 111-1.5" chrome-plated flush valve with vacuum breaker, quiet-action, and screw driver stop. Provide with flush valve so that handle is on wide side of stall.

Seat: Kohler "Lustra", No. K-4670-SC, white plastic seat, open-front and stainless steel self-sustaining check hinge.

Carrier: Cast iron or steel construction, adjustable to support fixture. J. R. Smith "Linebacker" Figure 115 to 280, type to suit application. Provide with rear anchoring lug on single units.

Plumbing Brass: Chicago stop and chrome plated brass supply.

**KOPACHUCK STATE PARK
DAY USE DEVELOPEMENT**

C. Lavatories:

1. P-3A Lavatory - Wall Hung - Handicap:

Lavatory: Kohler "Greenwich", No. K-2030, 20" x 18", vitreous china lavatory with 8" faucet centers, for use with concealed arm carrier.

Plumbing Brass: Kohler No. K-7715 lavatory drain with perforated grate and 1-1/4" offset tailpiece; Kohler No. K-8998, 1-1/4" Cast brass "P" trap with cleanout; and Chicago Faucet loose key stops and flexible risers.

Faucet: Chicago Faucet No. 404 faucet, with no. 390 handles, 8" centers, vandal resistant, 1/2 GPM outlet/aerator, 5" spout.

Carrier: Steel construction, adjustable, anchored to floor, with concealed arms for high back lavatory support. J. R. Smith Figure 700 with accessories to suit application.

D. Sinks:

1. P-5A Sink - Kitchen:

Sink: Elkay Weldbilt wnsf8372, (3) 24"X24"X14" deep compartments, 24" drain boards left and right, 8" high backsplash, supporting legs. 14 gauge type 304 stainless steel construction. 1/4" radius corners. Sink drilled for two faucets on 8" centers.

Carrier: Provide steel wall mounting bracket to attach sink to wall.

Plumbing Brass: Elkay LK24RT rotary lever operated drain outlet fittings with 1 1/2" diameter tail piece. Cast brass P-traps. Chrome plated brass offset piping. Chicago stops.

Faucet: Two Chicago No. 540 wall mounted faucets. No. 390 handles, L12 swing spout, E3 aerator, Quatern ceramic cartridges, adjustable supply arms.

2. P-6A Service Sink:

Sink: Swanstone MS 2424 mop sink. Molded composite, 24"x24" basin. Provide vinyl rim guard and stainless steel wall guard.

Faucet: Chicago Faucet 540, wall mounted vacuum breaker spout with pail hook and wall brace.

Plumbing Brass: 3" cast brass drain, dome strainer and lint basket.

Faucet: Chicago faucet No. 897 wall mounted. Vacuum breaker spout with pail hook and wall brace. 3/4" hose thread outlet, Quatern ceramic cartridges, adjustable supply arms, rough chrome finish.

**KOPACHUCK STATE PARK
DAY USE DEVELOPEMENT**

E. Drinking Fountains

1. P-8A Drinking Fountain:

Fixture: Elkay Outdoor Fountain Wall Mount Non-Filtered, Non-Refrigerated Freeze Resistant. Features shall include 316 Stainless, Heavy Duty Vandal Resistant, Sealed Freeze Resistant. Furnished with Vandal Resistant bubbler. Mechanical Front Bubbler Button activation. Product shall be Wall Mount (On Wall), for Outdoor applications, serving 1 station(s). Unit shall be lead-free design which is certified to NSF/ANSI 61 & 372 (lead free) and meets Federal and State low-lead requirements. Color as specified by architect.

F. Floor Drains

1. P-11A Floor Drain:

JR Smith Fig. 2005. Cast iron drain body with round nickel-bronze strainer. Vandal-proof screws

G. Hydrants and Hose Bibbs:

1. P-10A Wall Hydrant – Hot and Cold Mixing:

ZURN Z1327-EZ Encased moderate climate hot/cold wall hydrant for narrow wall installation. Complete with bronze bodies, all brass interior parts, replaceable seat washers, screwdriver operated stop valves in supply, handle operated control valves, 3/4 [19] IP female inlets and 3/4 [19] male hose connection standard, stainless steel box and removable hinged cover with cylinder lock and "WATER" stamped on cover. Complete with mounting brackets and hardware for installation and horizontal adjustment inside a 16 [406] on center stud wall.

2. P-10A Wall Hydrant – Freeze Proof, Vandal Resistant:

ZURN Z1305 Encased, non-freeze, flush wall hydrant with bronze casing, all bronze interior parts, non-turning operating rod with free floating compression closure valve, replaceable bronze seat and seat washer, and combination 3/4" female or 1" male straight IP inlet. Nickel bronze box and hinged cover with operating key lock and "WATER" cast on cover.

H. Instantaneous Water Heaters:

1. Type: Electric, point-of-use instantaneous booster type heaters.
2. Construction: Unit shall have copper clad immersion heating element(s) with brass terminations for increased durability Unit shall be for use with electricity as scheduled use with electricity as schedule on the plans. Unit shall be UL listed and on the plans. Unit shall be UL listed and meet all applicable codes.
3. Capacity: External temperature control and display adjustable in 1° increments with a range of 80°-140°F. Unit shall utilize a flow meter with a 0.3 gpm activation point and manage power based on actual flow rate and inlet temperature. Values should be processed 60 times per second.

**KOPACHUCK STATE PARK
DAY USE DEVELOPEMENT**

I. Water Heaters

1. Heaters shall be rated as shown on drawings and listed by Underwriters' Laboratories. Models shall meet the standby loss requirements of the U.S. Department of energy and current edition of ASHRAE/IES 90.1.
2. Tanks shall be of gallon capacity listed on drawings. Heaters shall have 150 psi working pressure and be equipped with extruded high density anode rod. All internal surfaces of the heater(s) exposed to water shall be glasslined with an alkaline borosilicate composition that has been fused-to-steel by firing at a temperature range of 1400°F to 1600°F.
3. Electric heating elements shall be medium watt density with zinc plated copper sheath. Each element shall be controlled by an individually mounted thermostat and high temperature cutoff switch.
4. The outer jacket shall be of backed enamel finish and shall enclose the tank with foam insulation. Electrical junction box with heavy duty terminal block shall be provided.
5. The drain valve shall be located in the front for ease of servicing.
6. Heater tank shall have a three year limited warranty as outlined in the written warranty.

2.3 SPECIALTIES

A. Unless indicated otherwise, the following fittings and materials shall be used:

1. Fixture Traps: 17 gauge seamless chrome plated tubing, with 2 inch minimum seal, size as required by Uniform Plumbing Code and to suit construction.
2. Exposed piping and fittings in finished areas and in accessible cabinets: Chrome plated or sleeved with chromed sleeves; all chrome to have a bright polished finish. No exposed copper allowed (includes accessible cabinet areas).
3. Stops: 1/4 turn ball valve type. Stops shall be with loose key.
4. Escutcheons: Chrome plated, one piece.

B. Rims: Lavatories and sinks mounted in the counterwork shall be self-rimming or equipped with deck stainless steel rims similar and equal to the Hudee Rim.

C. Vacuum Breakers: Anti-siphon vacuum breaker, by same manufacturer as flush valve or faucet with which used.

D. Carriers: Provided for wall mounted fixtures, type to suit construction. J.R. Smith or equal.

E. Sealant: Silicone type, General Electric type SCS1202 series or Dow Chemical equal, color to match fixture.

PART 3 - EXECUTION

3.1 INSTALLATION OF FIXTURES

- A. All fixtures shall be completely connected to piping as needed to make a complete and operable installation.

**KOPACHUCK STATE PARK
DAY USE DEVELOPEMENT**

- B. All wall mounted water closets, urinals, lavatories, drinking fountains and sinks shall be installed with supporting carriers that transmit the load to the floor.
- C. All wall mounted fixtures that standard carriers are not manufactured for, shall be supported with bolts through the wall which attach to a 3/16" thick steel back plate for block walls and wood stud walls; or a 2" x 2" x 1/4" angle welded to at least four studs for metal stud walls.
- D. Where plumbing fixtures abut to walls and floors, seal all joints with a uniform fillet bead of silicone sealant.
- E. Mounting heights and locations of fixtures shall be as shown on the Architectural drawings; these locations shall be verified and coordinated with the various trades affected by the installation of these fixtures. When not indicated or shown, obtain mounting location and heights from the Architect/Engineer prior to installation.
- F. Protect fixtures against use and damage during construction; provide guards and/or boxing as required.
- G. Pipe all pressure relief valves to nearest floor drain.
- H. In toilet rooms where only one (1) urinal is shown, that urinal shall be ADA accessible.

3.2 INSTALLATION OF SPECIALTIES

- A. Escutcheons: Provide escutcheons at each point where an exposed pipe or other fitting passes through walls, floors, backs of cabinets or ceilings.
- B. Stops: Provide stops in all water connections to all lavatories and sinks.
- C. Vacuum Breakers: Provide vacuum breakers with all flush valves and service sink faucets and where indicated on the drawings.

3.3 ADJUSTMENT AND CLEANING

- A. After completion of installation remove all labels and thoroughly clean all fixtures, trim and fittings.
- B. Adjust all flush valves, fixture stops, valves, and associated plumbing items as necessary for the proper operation of all equipment.

END OF SECTION 224000

**KOPACHUCK STATE PARK
DAY USE DEVELOPEMENT**

SECTION 230500 – GENERAL HVAC REQUIREMENTS

PART 1 - GENERAL

1.1 WORK INCLUDED

- A. General HVAC Requirements.
- B. HVAC Submittals.
- C. Motors.
- D. Equipment and Piping Identification.
- E. Commissioning.

1.2 GENERAL

- A. Includes, but not limited to, furnishing labor, materials, and equipment for completion of work unless indicated or noted otherwise. See Division 1 for sequence of work.
- B. All work included in Division 23 shall be the responsibility of a single HVAC Subcontractor. This Contractor shall obtain and pay for all permits required by State and local authorities governing the installation of the HVAC work. It is the Contractor's responsibility to contact all utility organizations serving the building, prior to bid, and to include all charges for inspections, installation of materials, equipment and connection of all required utilities.
- C. Furnish exact location of electrical connections and complete information on motor controls to Division 26.
- D. The drawings and specifications are complementary and what is called for in either is binding as if called for in both.
- E. The ductwork and accessibility to HVAC equipment shall take precedence over all other equipment in the ceiling interstitial spaces or other mechanical areas including, but not limited to, domestic water piping and electrical conduit.
- F. All HVAC equipment and devices furnished or installed under other Divisions of this specification (or by the Owner) which require connection to any mechanical systems (i.e., plumbing systems or duct systems, or controls) shall be connected under this division of the Specifications.
- G. The Contractor shall be responsible for checking field conditions and verifying all measurements and relationships indicated on the drawings before proceeding with the work.

1.3 ELECTRICAL

- A. All electrical work, conduit, boxes and devices in connection with control wiring as required to install the control equipment as specified herein or shown on the drawings shall be furnished and installed complete by the Division 23 Contractor.
- B. All electrical work performed under this section of the Specifications shall conform to all applicable portions of the Division 26 specifications and shall conform to all governing codes.
- C. All equipment shall be factory wired to a junction box for connection to electrical service.

**KOPACHUCK STATE PARK
DAY USE DEVELOPEMENT**

- D. Where a piece of equipment specified includes an electric motor, the motor shall be furnished and mounted by this Contractor. Motor starter, disconnect switches and wiring from the electrical panel to the motor control devices and to the motor shall be provided by the Division 26 Contractor unless stated otherwise in the HVAC specification and on the HVAC equipment schedule.

1.4 SYSTEMS DESCRIPTION

A. Site Inspection:

- 1. Examine premises and understand the conditions which may affect performance of work of this Division before submitting proposals for this work.
- 2. No subsequent allowance for time or money will be considered for any consequence related to failure to examine site conditions.

B. Drawings:

- 1. HVAC drawings show general arrangement of ductwork, equipment, etc. Follow as closely as actual building construction and work of other trades will permit.
- 2. Consider electrical drawings part of this work insofar as these drawings furnish information relating to design and construction of building.
- 3. Because of small scale of HVAC drawings, it is not possible to indicate all offsets, fittings, and accessories which may be required. Investigate structural and finish conditions affecting this work and arrange work accordingly, providing such fittings, valves, and accessories required to meet conditions.

1.5 SUBMITTALS

- A. All material used on the project shall be new and free of defects. The Engineer reserves the right to reject any material, the appearance of which has been damaged on the site or in shipment. The material shall be of approved equal quality to that which is specified. Should the make and type of material differ from that specified, the Contractor may be required to submit catalog and engineering data (samples if requested) necessary to make a comparison and determine its suitability. The Contractor shall also bear the cost of any changes to the electrical design made necessary by any approved substitutions. Such request for approval shall be made two weeks in advance of the bid opening to allow time to assess its suitability. Failure to obtain approval prior to bid shall require the successful bidder to furnish materials and equipment only as specified herein.
- B. The Contractor shall submit to the Engineer, for approval, complete information on all equipment and materials to be provided on the project. Include the manufacturer's catalog and engineering data, shop drawings of shop fabricated equipment and instruction data for each item included under this section of the specifications. Submittals shall be presented to the Engineer within 30 calendar days from the date of the contract signing in complete indexed and bound sets. The Contractor shall submit a typed, signed list including all items to be furnished on the project. The signature on the aforementioned list shall indicate that the contractor has examined the suitability of all material and equipment with respect to compliance with these specifications. The Contractor's approval shall also indicate that physical dimensions of the equipment have been verified with the installation requirements and were found to cause no interference therewith.
- C. Review of submittal data by the Engineer or Engineer does not relieve the Contractor of responsibility for quantities, measurements, and compliance with the intent of all contract documents.

**KOPACHUCK STATE PARK
DAY USE DEVELOPEMENT**

- D. Furnish submittals on all items and equipment specified in Division 23 and all items indicated on HVAC drawings in a hard-back, three-ring binder.
- E. The Contractor shall submit the HVAC cost breakdown including all sub-contractors costs.

1.6 OPERATION AND MAINTENANCE MANUAL FOR HVAC SYSTEMS

- A. Bind Operation & Maintenance Manual for HVAC Systems in three-ring, hard-backed binder with clear plastic pocket on spine. Spine of each binder shall have following typewritten lettering inserted:

OPERATION AND MAINTENANCE MANUAL
FOR HVAC SYSTEMS

- B. Provide master index at beginning of Manual showing items included. Use plastic tab indexes for sections of Manual.
- C. First section shall consist of name, address, and phone number of Engineer, General Contractor, and Mechanical, Plumbing, Sheet Metal, Refrigeration, Temperature control, and Electrical subcontractors. Also include complete list of equipment installed with name, address, and phone number of each vendor.
- D. Provide section for each type of item of equipment.
- E. Submit copies of Operation & Maintenance Manual to Engineer for approval.
- F. Include descriptive literature (Manufacturer's catalog data) of each manufactured item. Literature shall show capacities and size of equipment used and be marked indicating each specific item with applicable data underlined.
- G. Operating Instructions shall include:
 - 1. General description of each HVAC system.
 - 2. Step-by-step procedure to follow in putting each piece of HVAC equipment into operation.
- H. Maintenance Instructions shall include:
 - 1. Manufacturer's maintenance instructions for each piece of HVAC equipment installed in Project. Instructions shall include name of vendor, installation instructions, parts numbers and lists operation instructions of equipment, and maintenance and lubrication instruction.
 - 2. Summary list of HVAC equipment requiring lubrication showing name of equipment, location, and type and frequency of lubrication.
 - 3. List of HVAC equipment used indicating name, model, serial number, and nameplate data of each item together with number and name associated with each system item.

1.7 QUALITY ASSURANCE

- A. Requirements of Regulatory Agencies:
 - 1. Perform work in accordance with applicable Codes.
 - 2. In case of differences between building codes, state laws, local ordinances, utility company regulations, and Contract Documents, the most stringent shall govern.
- B. Product Approvals: See paragraphs elsewhere in this specification.
- C. Manufacture: Use domestic made duct, duct fittings, and motors on Project.

**KOPACHUCK STATE PARK
DAY USE DEVELOPEMENT**

- D. Identification: Motor and equipment name plates as well as applicable UL and AGA labels shall be in place when Project is turned over to Owner.

1.8 CODES AND STANDARDS

- A. Codes and agencies having jurisdictional authority over HVAC installation.
 - Washington State Energy Code
 - International Building Code -- Latest Approved Edition
 - International Mechanical Code -- Latest Approved Edition
 - International Fuel Gas Code – Latest Approved Edition
 - State and County Department of Health
 - Occupational Safety and Health Administration (OSHA)
 - Washington Industrial Safety and Health Act (WISHA)

1.9 PRODUCT HANDLING AND PROTECTION

- A. Contractor is responsible for protection of all material, equipment and apparatus provided under this section from damage, water, corrosion, freezing and dust, both in storage and when installed, until final project acceptance.
- B. Provide temporary heated and sheltered storage facilities for material and equipment.
- C. Completely cover motors and other moving machinery to protect from dirt and water during construction.
- D. Handle and protect equipment and/or material in manner precluding unnecessary fire hazard.
- E. Equipment requiring rotation and/or lubrication during storage shall have records maintained and witnessed on a monthly basis and forwarded to the Engineer prior to acceptance.
- F. Material or equipment damaged because of improper storage or protection will be rejected.
- G. Equipment finish that is damaged by handling, storage, etc. shall be corrected by the Contractor at no additional cost to the Owner.

1.10 WARRANTIES

- A. In addition to guarantee specified in General Conditions, guarantee heating, cooling, and plumbing systems to be free from noise in operation that may develop from failure to construct system in accordance with Contract Documents.
- B. In order to be protected, secure proper guarantees from suppliers and subcontractors.
- C. Provide certificates of warranty for each piece of equipment. Clearly record "start-up" date of each piece of equipment on certificate. Include certificates as part of Operation & Maintenance Manual.

1.11 ABBREVIATIONS

AFF	Above Finish Floor
AMCA	Air Moving & Conditioning Association
ANSI	American National Standards Institute
APWA	American Public Works Association

KOPACHUCK STATE PARK DAY USE DEVELOPEMENT

ARI	Air Conditioning and Refrigeration Institute
ASHRAE	American Society of Heating, Refrigerating and Air Conditioning Engineers
ASME	American Society of Mechanical Engineers
ASTM	American Society of Testing & Materials
AWWA	American Water Works Association
BFF	Below Finish Floor
BHP	Brake Horsepower
BTU	British Thermal Unit
CFC	Chloro - Fluorocarbon
CFM	Cubic Feet per Minute
DOT	US Department of Transportation
EPA	Environmental Protection Agency
fpm	feet per minute
FS or Fed.	Spec. Federal Specifications
HP	Horsepower
IEEE	Institute of Electrical and Electronics Engineers
KW	Kilowatt
MBH	One Thousand British Thermal Units per Hour
MS or Mil.Spec.	Military Specifications
MSS	Manufacturers Standardization Society
NEC	National Electrical Code
NEMA	National Electrical Manufacturers Association
per	in accordance with
PVC	Polyvinyl Chloride
SMACNA	Sheet Metal and Air Conditioning Contractors National Association
SP	Static Pressure
UL	Underwriter's Laboratories
w.g.	Water Gauge (inches of water)
WQA	Water Quality Association

Additional abbreviations are as listed on the drawings or elsewhere in these specifications.

1.12 DEFINITIONS

- A. Finished Spaces: Spaces used for habitation or occupancy where rough surfaces are plastered, panelled, or otherwise treated to provide a pleasing appearance.
- B. Unfinished Spaces: Spaces used for storage or work areas where appearance is not a factor.
- C. Concealed Spaces: Spaces out of sight. For example, above ceilings; below floors; between double walls; furred-in areas; pipe and duct shafts; and similar spaces.
- D. Exposed: Open to view. For example, duct running through a room and not covered by other construction.

**KOPACHUCK STATE PARK
DAY USE DEVELOPEMENT**

- E. Outside: Open to view up to 5 feet beyond the exterior side of walls, above the roof, and unexcavated or crawl spaces.
- F. Conditioned Space: An area, room or space normally occupied and being heated or cooled for human habitation by any equipment.

PART 2 - PRODUCTS

2.1 ACCEPTABLE MANUFACTURERS

- A. Any reference to the specifications or on the drawings to any article, device, product, material, fixture, form or type of construction by manufacturer, name, make, or catalog number shall be interpreted as establishing a standard of quality and shall not be construed as limiting competition.
- B. The manufacturer listed as Acceptable Manufacturers are approved for the items indicated without obtaining prior approval. Other manufacturers require prior approval.
- C. The listing of a manufacturer as an Acceptable Manufacturer does not necessarily mean that the products of that manufacturer are equal to those specified. The listing is only an indication of those manufacturers which may be capable of manufacturing, or have in the past manufactured, items equal to those specified, and is intended to aid the Contractor in identifying manufacturers.
- D. Products provided by Acceptable Manufacturers shall be equal to or superior to the specified manufacturer's item in function, appearance, and quality, and shall fulfill all requirements of the plans and specifications. The Engineer shall be the final judge as to whether an item meets these requirements or not. If a manufacturer is not certain that his product meets these requirements or not, then the manufacturer shall submit data as required to obtain the Design Consultant's approval.
- E. The approval of a manufacturer applies to the manufacturer only and does not relieve the Contractor from the responsibility of meeting all applicable requirements of the plans and specifications.
- F. Contractor shall be responsible for all costs to other trades and all revisions required to accommodate any products which are different than those specified or shown.
- G. In reviewing a manufacturer for acceptance, factors considered include the following: engineering data showing item's performance, proper local representation of manufacturer, likelihood of future manufacturer's local support of product, service availability, previous installation, previous use by Owner/Engineer and record, product quality, availability/quality of maintenance and operation data, capacity/performance compared to specified items, acoustics, items geometry/access utility needs, and similar concerns.
- H. If approval is received to use other than specified items, responsibility for specified capacities and insuring that items to be furnished will fit space available lies with this Division.
- I. If non-specified equipment is used and it will not fit job site conditions, this Division assumes responsibility for replacement with items named in Specification.

**KOPACHUCK STATE PARK
DAY USE DEVELOPEMENT**

2.2 ACCESS DOORS

- A. This contractor shall be responsible for furnishing and installing flush mounted access doors in walls, ceiling and floors and chases where the following equipment is concealed and is not accessible through same.
 - 1. Valves (shut off)
 - 2. Dampers (balancing)
 - 3. Electric Heater Control Panels
 - 4. Fire Smoke Dampers
 - 5. HVAC Controls and Actuators
- B. Doors shall be UL listed 16 ga. cold rolled steel with concealed hinge, screwdriver operated lock and prime coated. Furnish suitable for area mounted.
- C. Approved Manufacturers:
 - 1. Milcor
 - 2. Karp
 - 3. Greenheck

2.3 EQUIPMENT AND PIPING IDENTIFICATION

- A. General: All ducting, valves, and HVAC equipment shall be marked. All markings in concealed accessible spaces shall be reviewed and verified by Architect/Engineer prior to being concealed.
- B. Valves shall be marked as follows:
 - 1. Identification tags made of brass or aluminum, stamped with valve number and abbreviation of system served (HTG, PLBG, CW, HW, GAS, AC). Tags shall be installed on all valves except stops at plumbing fixtures. Tags shall be not less than 1-1/2 inch in diameter, markings shall be stamped and black filled, and lettering shall be minimum 1/4-inch high with numbers minimum 1/2-inch high. Tags shall be wired to each valve with No. 6 polished nickel-steel jack chain.
- C. All HVAC equipment which was scheduled on the Contract Drawings shall be marked with the name of the item; i.e., Heating Ventilating Unit No. 1, Exhaust Fan No. 2, Boiler No. 1 etc. The identification shall be the same as shown on the Contract Drawings. The marking shall be located on two different sides of the equipment so as to be easily read, with at least one marking visible to a person standing at floor level near the unit (assuming any necessary access to a concealed unit has been made). Lettering shall be a minimum of 2" high. Marking shall be with engraved phenolic labels, white letters on black background. Equipment marking is not required for; air outlets and inlets, plumbing fixtures.
- D. All HVAC control equipment shall be marked with phenolic labels. Equipment shall be marked to match the tags used in the programming of the control equipment.

PART 3 - EXECUTION

3.1 WORKMANSHIP

- A. This Contractor shall provide completed systems with a neat and finished appearance. If, in the judgment of the Engineer, any portion of the work has not been performed in a workmanlike manner or is left in a rough, unfinished state, this Contractor will be required to remove, reinstall

**KOPACHUCK STATE PARK
DAY USE DEVELOPEMENT**

or replace same and patch and paint surrounding surfaces in a manner acceptable to the Engineer, without increase in cost to the Owner.

3.2 CLOSEOUT SUBMITTALS

- A. Requirements: Final approval of mechanical installation will be recommended upon completion of the following:
 - 1. Completion of all punchlist items
 - 2. Operation instruction period to Owner's satisfaction
 - 3. Permit Submittal
 - 4. Valve list posted
 - 5. Reproducible As-Built drawings delivered to Engineer
 - 6. Guarantees
 - 7. Equipment Manufacturer of all HVAC compressor units shall provide start-up logs.

3.3 FINAL INSPECTION

- A. Final Inspection:
 - 1. Prior to acceptance of the HVAC work, the Contractor shall put all HVAC systems into operation for a period of not less than 5 working days so that they may be inspected by the Engineer and the Owner's representatives.
 - 2. The time of the final inspection shall be mutually agreed to by the Owner, Engineer, and Contractor.
 - 3. The Contractor shall furnish adequate staff to operate the HVAC systems during inspection.

3.4 OPERATION AND MAINTENANCE TRAINING

- A. Upon completion of the work, and after all tests and final inspection of the work by the Authority(s) having jurisdiction, the Contractor shall demonstrate and instruct the Owner's designated operation and maintenance personnel in the operation and maintenance of the various HVAC systems. The Contractor shall arrange scheduled instruction periods with the Owner. The Contractor's representatives shall be Superintendents or Foremen knowledgeable in each system and Supplier's Representative when so specified.

- B. Scheduled instruction periods shall be:

HVAC System Controls	1 Hours
HVAC Equipment Maintenance	4 Hours

- C. Costs for time involved by Contractor shall be included in the bid.

3.5 INSTALLATION

- A. Install HVAC equipment to permit easy access for normal maintenance, and so that parts requiring periodic replacement or maintenance, (e.g., coils, heat exchanger bundles, sheaves, filters, meters, bearings, etc.) can be removed. Relocate items which interfere with access.
- B. Provide access doors in equipment, ducts, and walls/ceilings as required to allow for inspection and proper maintenance.

KOPACHUCK STATE PARK DAY USE DEVELOPEMENT

- C. If circumstances at a particular location make the accessible installation of an item difficult or inconvenient, the situation shall be discussed with the Engineer before installing the item in a poor access location.
- D. Belts, pulleys, couplings, projecting set screws, keys and other rotating parts which may pose a danger to personnel, shall be fully enclosed or guarded in accordance with OSHA regulations.
- E. Dissimilar Metals: Provide separations between all dissimilar metals. Where not specified in another way, use 10 mil black plastic tape wrapped at point of contact or plastic centering inserts.
- F. Provide offsets around all electrical panels (and similar electrical equipment) to maintain space clear above and below panel to structure and clearance of 3 feet directly in front of panel, except where indicated otherwise or required by NEC to be more. Such offsets are typically not shown on the drawings, but are required per this paragraph.
- G. Safety Protection: All ductwork, piping and related items installed by this Contractor that present a safety hazard (i.e., items installed at/near head height, items projecting into maintenance access paths, etc.) shall be covered (at hazardous area) with 3/4" thick elastomeric insulation and 2" wide reflective red/white striped self-sticking safety tape.
- H. Equipment Access: Access to equipment is of utmost importance. Contractor shall apply extra attention to the laying out of duct routings, and in coordinating all work. Poor access to equipment will not be accepted. Dashed areas at HVAC units indicate equipment access areas. These (and all other) access areas shall be clear of obstructions. The Division 23 contractor is responsible to coordinate and insure that all trades stay clear of access areas for any Division 23 furnished equipment.
- I. Insure that items to be furnished fit space available. Make necessary field measurements to ascertain space requirements including those for connections and furnish and install equipment of size and shape so final installation shall suit true intent and meaning of Contract Documents.

3.6. ADJUSTMENT AND CLEANING

- A. Properly lubricate equipment before Owner's acceptance.
- B. Clean exposed ductwork, equipment, and fixtures, remove debris from site. Repair damaged finishes and leave everything in working order.
- C. All work areas shall be left broom clean and free of debris. Sweep HVAC rooms at completion of work, and dispose of waste. Dispose of all existing waste in HVAC rooms in addition to waste generated by this work.

3.7 COMMISSIONING

- A. The Contractor has specific responsibilities relating to demonstrating the equipment and systems provided have been installed and function per the contract specifications. These responsibilities include, but are not limited to the following:
 - 1. Complete all equipment and system start-up and checkout procedures, and to insure the complete readiness of equipment and systems, prior to the start of the functional performance testing phase of the commissioning process.
 - 2. Functional test all HVAC systems in accordance with the Washington State Energy Code. Demonstrate system performance to the Engineer.
 - 3. Provide to the Owner a written commissioning process and the results of the functional performance testing.

**KOPACHUCK STATE PARK
DAY USE DEVELOPEMENT**

- B. Owner shall not accept equipment and systems, and Owner shall not make final payment, until all equipment and systems have been successfully commissioned and all specified requirements have been satisfied.

END OF SECTION 230500

**KOPACHUCK STATE PARK
DAY USE DEVELOPEMENT**

SECTION 230529 – HVAC HANGERS AND SUPPORTS

PART 1 - GENERAL

1.1 WORK INCLUDED

- A. Duct Hangers
- B. Equipment Hangers

1.2 QUALITY ASSURANCE

- A. Duct Hanger Standards: (MSS) Manufacturers Standardization Society Standards SP-58-1975, SP-89-1978, and SP-69-1976.
- B. All methods, materials and workmanship shall conform to the International Building Code (IBC) and International Mechanical Code (IMC), as amended and adopted by the authority having jurisdiction.

1.3 SUBMITTALS

- A. Submittals shall comply with Section 230500 – General HVAC Requirements.
- B. Submit product data. Indicate where such items are to be used.
- C. Shop drawings are required for all equipment supports and fabricated supports or assemblies.

PART 2 - PRODUCTS

2.1 ACCEPTABLE MANUFACTURERS

- A. Hangers and Supports: Elcen, Grinnell, B-Line Systems, Unistrut, Michigan, Tolco.
- B. Anchors: Rawplug, Phillips, Hilti, Michigan.

2.2 GENERAL HANGERS AND SUPPORTS

- A. Hanger Rods: Threaded hot rolled steel, electro-galvanized or cadmium plated. Hanger rods shall be sized so that the total load (including pipe or duct, insulation, hangers, and fluid) does not exceed the following:

<u>Nominal Rod Diameter</u>	<u>Maximum Load</u>
1/4 Inch	240 Pounds
5/16 Inch	440 Pounds
3/8 Inch	610 Pounds
1/2 Inch	1130 Pounds

**KOPACHUCK STATE PARK
DAY USE DEVELOPEMENT**

B. Hanger Straps: Galvanized steel. Straps shall be sized so that the total load does not exceed the following:

Strap Size	Maximum Load
1" x 22 Gauge	230 Pounds
1" x 20 Gauge	290 Pounds
1" x 18 Gauge	380 Pounds
1' x 16 Gauge	630 Pounds

C. Beam Attachments: Shall be of the following type:

MSS Type	Elcen Figure No.	Grinnell Figure No.
21	33,34	131
22	67	66
23	29A	87
28	95	292, 228
30	95	229

D. Steel: Structural steel per ASTM A36.

E. Wood: Shall be fire treated.

2.3 DUCT HANGERS AND SUPPORTS

- A. Hangers: As shown in SMACNA HVAC Duct Construction Standards.
- B. Vertical Duct Supports at Wall: 1-1/2" x 1/8" (minimum) strap or 1-1/2" x 1-1/2" x 1/8" (minimum) angle bracket and as shown in SMACNA HVAC Duct Construction Standards Figure 4-7.
- C. Hanger Attachments to Structure: As shown in SMACNA HVAC Duct Construction Standard Figures 4-1, 4-2, 4-3 to suit building construction and as allowed on structural drawings. Where C-clamps are provided, retainer clips shall be used. Friction beam clamps shall not be used.
- D. Hanger Attachments to Ducts: As shown in SMACNA HVAC Duct Construction Standards Figure 4-4.
- E. Rooftop Supports: Polyethylene platform with galvanized steel strut. Foam bottom for contact with roof membrane. Load rated for a minimum of 1000 Lbs. Provide galvanized steel straps sized as hanger straps, Erico Caddy Pyramid ST or approved.

PART 3 - EXECUTION

3.1 INSTALLATION – GENERAL

- A. Provide all necessary bolts, nuts, washers, turnbuckles, rod connectors and any other miscellaneous accessories required for the support and anchoring of all ducts, and HVAC equipment.

**KOPACHUCK STATE PARK
DAY USE DEVELOPEMENT**

- B. Install steel or wood backing in walls (anchored to studs) as required to provide support for items hung from walls. Backing shall be of the same material as the studs or structure they are attached to.
- C. All welded steel support assemblies shall have a power wire brush and primer paint finish.
- D. Attach to building structure as shown on drawings.
- E. Maximum spans between piping supports may be significantly less than the maximum spans allowed herein due to structural limitations of allowable loads on hangers. The most restrictive criteria governs. Reference structural drawings.

3.2 INSTALLATION OF DUCT HANGERS AND SUPPORTS

- A. Provide anchors and supports for all ductwork.
- B. Rectangular Duct: Supports and hangers shall be of size and spacing as shown in SMACNA HVAC Duct Construction Standards for the appropriate class of duct. (Hangers maximum allowable loads shall not be as shown in SMACNA Tables but shall be as specified in these specifications.)
- C. Round Duct: Supports and hangers shall be of size and spacing as shown in SMACNA HVAC Duct Construction Standards for the appropriate class of duct.
- D. Maximum Hanger Spacing (provided duct gauge and reinforcement comply with SMACNA Standards for such spacing):

<u>Duct Area</u>	<u>Maximum Spacing</u>
Up to 4 sq. ft. (27" dia)	8 Feet
4.1 to 10 sq. ft. (28" to 42" dia)	6 Feet
10.1 sq. ft. and up (43" dia and up)	4 Feet

- E. Provide supports at each change in direction of duct. Locate hangers at inside and outside corners of elbows, or at each end of fitting, on each side.
- F. Provide additional supports at each side concentrated loads (such as modulating dampers, duct heaters, sound attenuators, etc.)
- G. Provide supports for exterior ductwork per SMACNA HVAC Duct Construction Standards or as detailed on the drawings.

3.3 INSTALLATION OF HVAC EQUIPMENT ANCHORS AND SUPPORTS

- A. Provide anchoring and supports for all HVAC equipment.
- B. Heating, Ventilating and Air Conditioning equipment where suspended from structure shall be supported per SMACNA HVAC Duct Construction Standards or as shown on the drawings.
- C. Equipment shall be supported and anchored in such a way so that no equipment vibration is transmitted to the building structure.
- D. Added supports and bracing shall be provided per Section 230548 – HVAC Vibration & Seismic Control.

END OF SECTION 230529

**KOPACHUCK STATE PARK
DAY USE DEVELOPEMENT**

SECTION 230548 – HVAC VIBRATION & SEISMIC CONTROL

PART 1 - GENERAL

1.1 WORK INCLUDED

- A. Vibration Isolators
- B. Seismic Restraints

PART 2 - PRODUCTS

2.1 NEOPRENE ISOLATORS

- A. Suspension Isolators: Shall be double deflection neoprene type, with isolator encased in open steel bracket and minimum 3/8-inch deflection. Hanger rod shall be isolated from steel bracket with neoprene grommets. Mason Series HD, Amber Booth "BRD" or approved.

2.2 SPRING ISOLATORS

- A. General: The load carried by each isolator shall be calculated and isolators selected so that the static deflection will be the same and the supported equipment will remain level. Isolators shall be so designed that the ends of the springs will remain parallel during and after deflection to operating height. At operating height, springs shall have additional travel to complete (solid) compression equal to at least 50 percent of the operating deflection. Suspension isolator springs shall have a static deflection (as shown on drawings) not less than 1-1/2", except that for units with components rotating at 1000 rpm and less, the static deflection shall be not less than 2 inches. Floor isolator springs shall have deflection of not less than 1 inch. All isolators shall provide at least 96% isolation efficiency. Note: Deflections other than these may be used where circumstances warrant and more optimum isolation results can be achieved.
- B. Suspension Type Spring Isolators: Shall consist of a rigid steel frame, a stable steel spring in the bottom part of the frame, and double deflection neoprene isolating pad at the top of the frame. Where supporting rods pass through the frame, a clearance of not less than one half rod diameter shall be provided all around the rod. Mason Series DNHS, Amber Booth "BSSR" or approved.

2.3 SEISMIC RESTRAINTS

- A. Materials: Steel shall be per STM A36; hangers and other devices shall be as shown in SMACNA Seismic Restraint Manual Guidelines for Mechanical Systems latest edition. Sheet metal used for bracing shall be no less than 16 gauge. Cable bracing may be used provided that opposed acting cables are provided on the items being braced to provide bracing equal to that provided by rigid angle bracing

**KOPACHUCK STATE PARK
DAY USE DEVELOPEMENT**

PART 3 - EXECUTION

3.1 INSTALLATION

A. Vibration Isolation:

1. Motorized equipment shall be suspended from spring vibration isolators either integral or external to the equipment.
2. Unless otherwise indicated, resilient mounts for motorized equipment shall be of the type and size to provide maximum ten percent transmissibility. Use unhoused, free-standing stable steel springs which are preferred over housed spring assemblies. The horizontal stiffness of the spring shall be approximately equal to its vertical stiffness. The Spring deflection shall be selected based on the equipment power range (HP), speed range (RPM), and static deflection of the supporting structural floor. For large equipment such as fans the steel spring static deflection of the supporting structural floor. It is a specific recommendation that whenever a steel spring is used, two pads of ribbed waffle-pattern neoprene be used in series with the spring.
3. The design of vibration dampening shall consider lateral load as well as vertical load and be suitably snubbed against earthquake forces.
4. A list of isolators accompanied by certified transmissibility ratings for the required duty shall be submitted for each item of equipment.
5. Unless noted otherwise, all vibration isolating equipment shall be of the same make and shall be submitted as one group.
6. Special equipment, such as compressors shall be selected on an individual basis.

3.2 SEISMIC CONTROL

- A. Provide earthquake snubbers for all equipment that is supported on spring isolators and weighing over 300 lbs. including base.
- B. Ductwork: Longitudinal and transverse bracing shall be required for all round ducts 28 inches in diameter and larger, for rectangular ducts 6 square feet and larger, and on all duct systems used for life safety and smoke control installed in either the horizontal or vertical position. Bracing shall be applied as follows:
 1. Transverse bracing shall occur at maximum intervals of 30 feet, at each duct turn and at the end of a duct run.
 2. Longitudinal bracing shall occur at maximum intervals of 60 feet. Transverse bracing for one duct section may also act as longitudinal bracing for a duct section connected perpendicular to it, if bracing is installed within 4 feet of the intersection and sized and installed on the larger duct.
 3. Groups of ducts may be combined in a larger size frame using overall dimensions and maximum weight of ducts. At least two sides of each duct must be connected to the angles of the brace.
 4. Walls, including non-bearing fixed partitions which have ducts running through them, may replace a transverse brace.
 5. Bracing may be omitted when the top of the duct is suspended 12 inches or less from the supporting structural members and on roof top ductwork.

END OF SECTION 230548

**KOPACHUCK STATE PARK
DAY USE DEVELOPEMENT**

SECTION 230593 AIR BALANCING

PART 1 - GENERAL

1.1 WORK INCLUDED

- A. Air Balancing.
- B. Report.

1.2 REFERENCES

- A. Associated Air Balance Council: National Standards for Field Measurements and Instrumentation.
- B. ASHRAE: 2001 Handbook of Fundamentals.
- C. American Conference of Governmental Hygienists: Industrial Ventilation, A Manual of Recommended Practice, 20th Edition.

1.3 GENERAL REQUIREMENTS

- A. General: The air and hydronic balancing shall be done by a company which specializes in this type of work and is totally independent and separate from the company or contractor which has installed the systems to be balanced.
- B. Prior to beginning balancing, submit the name of the company the Contractor proposes to have do the balancing to the Architect/Engineer for approval.
- C. Engineer: The final report of this work shall be stamped by a licensed Mechanical Engineer and accompanied by a statement from this engineer that the work complies with the Associated Air Balance Council Standards and these project specifications.
- D. Notify the Architect in writing of all problems or discrepancies between actual conditions and what design documents show as work proceeds.
- E. The Balancer shall be directly responsible to the Engineer and shall perform this work as directed by the Engineer.

PART 2 - PRODUCTS

2.1 GENERAL INSTRUMENTATION

- A. Balancing equipment shall comply with Associated Air Balance Council recommendations for field measurement instrumentation.
- B. All measuring instruments shall be accurately calibrated and maintained in good working order. Calibration dates and certifications shall be available at Engineer's request.
- C. Instruments shall be capable of:
 - 1. Air velocity instruments, direct reading in feet per minute with 2% accuracy.
 - 2. Static pressure instruments, direct reading in inches water gauge with 2% accuracy.
 - 3. Tachometers, direct reading in revolutions per minute with 1/2% accuracy; or revolution counter accurate with 2 counts per 1,000.
 - 4. Thermometers, direct reading in degrees Fahrenheit with 1/10 of a degree accuracy.

**KOPACHUCK STATE PARK
DAY USE DEVELOPEMENT**

5. Pressure gauges, direct reading in feet of water or psig with 1/2% accuracy.
6. Water flow instruments, direct reading in feet of water or psig with 1/2% accuracy suitable for readout of balancing valve provided.

PART 3 - EXECUTION

3.1 GENERAL

- A. All air systems shall be completely balanced and adjusted to provide the air and flow rates indicated, and to produce an even heating and cooling effect and control response.
- B. Consult and coordinate with the Section 230900 – Control Systems (Buildings) Contractor for the adjustment of all control devices to allow for proper system operation.
- C. Make final adjustments for flow rates in order to optimize each space's comfort, including such considerations as temperature, drafts, noise, pressurization, and air changes. Where variances are made from design values, state reasons in report (e.g., "too much noise", etc.). All such variances are subject to approval by the Architect/Engineer.
- D. All measurements and adjustments shall be in accordance with the Associated Air Balance Council National Standards.

3.2 AIR BALANCING

- A. Pre-check of System: Prior to beginning balancing, perform, as a minimum, the following:
 1. Verify that clean filters have been installed, that system is free from debris, and that all inlets/outlets are not obstructed.
 2. Check all fans and equipment to verify that proper start-up and system preparation has been done by the installing contractor.
 3. Check all door/window and similar building opening status to insure building is ready and proper pressurization can be obtained.
 4. Open all dampers to full flow position, check positions and operation of all motorized dampers to allow full system flows.
 5. Review controls and sequences of operation.
- B. Tolerances: All air flow rates (supply, return, and exhaust) shall be adjusted to within plus 5 percent and minus 5 percent of the values shown in the contract documents, except that relative space-to-space pressure relationships shall always be maintained (e.g., restrooms shall be negative relative to other areas, general offices shall be positive, etc.).
- C. All diffusers, grilles, and registers shall be adjusted to minimize drafts and to eliminate objectionable noise.
- D. Air balancing shall be done with new, clean air filters installed. Adjust air deliveries so that design quantities will be obtained when filters are half dirty. This condition shall be simulated by covering a portion of the filter area.
- E. Adjust fan speeds and fan drives as required to produce design air quantities.
- F. Measurements and adjustments of the air handling and distribution equipment shall be executed in a manner consistent with the manufacturer's recommendations.
- G. At completion of balancing, mark the final position of all balancing dampers and record all data.

**KOPACHUCK STATE PARK
DAY USE DEVELOPEMENT**

- H. Air flow measurements in main ducts shall be made with a duct traverse using a pitot tube and micromanometer. Summation of air terminal outlets and inlets is not sufficient. Quantity of duct leakage shall be indicated.
- I. Duct traverses in rectangular duct shall measure the center of equal areas in the air flow stream, with centers not more than 6 inches apart. Round duct traverses shall measure at least 20 locations, with locations being the centers of equal annular area. Reference the ACGIH Industrial Ventilation Manual, Chapter 9, Testing of Ventilation Systems.
- J. Balance each branch run so that there is at least one wide open run; balance branches relative to one another so that at least one branch damper is wide open.
- K. Requirements for All Air Handling Systems: Data to be measured/recorded and provided in report:
 - 1. Floor plans clearly showing and identifying all diffusers, grilles, O.A. louvers, ducts and all other items where air flow rates were measured.
 - 2. Identify manufacturer, model number, size, and type of all air inlets/outlets.
 - 3. Initial, trial, and final air flow measurements for all diffusers, grilles, O.A. louvers, ducts, and all other items where air flow rates were measured.
 - 4. Design air flow rates and percentage final air flow rates are of design values
 - 5. The connected voltage and corresponding nameplate full load amps, and the initial and final amperages of all fan motors.
 - 6. Initial and final RPMs of all fans.
 - 7. Static pressures on inlet and outlet of all units.
 - 8. Fan initial and final CFMs.
 - 9. Outdoor air CFMs (record minimum and maximum values).
 - 10. Data required for all equipment which are part of balanced systems:
 - a. Equipment name and number (as used on drawings).
 - b. Service.
 - c. Equipment manufacturer and model numbers.
 - d. Sheave and belt sizes (where applicable).
 - e. Filters sizes and quantities (where applicable).
 - f. Motor manufacturer and complete nameplate data.
 - g. Design operating conditions.
 - h. Actual operating conditions (flows, pressure drops, rpm, etc.).

3.4 BALANCING REPORT

- A. General: A balancing report shall be submitted as specified herein, documenting all balancing procedures and measurements.
- B. Preliminary Report: Two preliminary review copies of the balancing report shall be submitted to the Architect/Engineer when the balancing work is 90% complete (or as near 90% complete as possible due to uncompleted work of other trades). In addition to containing all the information required of the final report, the preliminary report shall contain a list of all the work required of other trades in order to allow the balancing work to be completed. The Architect/Engineer will review the preliminary report and inform the Contractor of any additional items or revisions required for the final report. Preliminary reports may be omitted where the Architect/Engineer grants approval.
- C. Final Report: Shall be included in the Operation and Maintenance Manual. Submit reports to Contractor for inclusion in Manuals (or, when manuals have been already sent to Engineer, send

**KOPACHUCK STATE PARK
DAY USE DEVELOPEMENT**

report to Engineer who will insert report into Manual). Provide number of reports as required to match quantity of O&M Manuals, but in no case less than five (5).

- D. Report Organization: The report shall be divided into logical sections consistent with the building or system layout (i.e. by floors, building wings, air handling units, or other convenient way). Tabulate data separately for each system. Describe balancing method used for each system.
- E. Format: 8-1/2" x 11" size, neat, clean copies, drawings accordion folded. Report shall be typed, shall have a title page, table of contents, and divider sheets with identification tabs between sections. Information shall be placed in a three-ring notebook, with the front cover labeled with the name of the Job, Owner, Architect/Engineer, Balancing Contractor, and Report Date.
- F. General Balancing Information Required:
 - 1. At the beginning of the report, include a summary of problems encountered, deviations from design, remaining problems, recommendations, and comments.
 - 2. List of instruments used in making the measurements and instrument calibration data.
 - 3. Names of personnel performing measurements.
 - 4. Explanation of procedures used in making measurements and balancing each system.
 - 5. List of all correction factors used for all diffusers, grilles, valves, venturi meters, and any other correction factors used.
 - 6. Areas where difficulties were encountered in obtaining design flow rates, or where unstable operating conditions may exist.
 - 7. Note any parts of the system where objectionable drafts or noises may be present and efforts made to eliminate same and why they may still be present.
 - 8. Note where variances from design values occur; explain why.
- G. Air Balancing Information: All previously cited required measurement/recorded data, any additional recorded data, and observations.

END OF SECTION 230593

**KOPACHUCK STATE PARK
DAY USE DEVELOPEMENT**

SECTION 230700 – HVAC INSULATION

PART 1 - GENERAL

1.1 WORK INCLUDED

- A. Duct Insulation.
- B. Equipment and Specialties Insulation.

1.2 DEFINITIONS

- A. "Run-out" means "piping not more than 12 feet long that runs to an individual fixture or unit."
- B. "Conditioned Areas" means "areas that are directly and intentionally supplied by heated or cooled air".

1.3 QUALITY ASSURANCE

- A. All insulation shall have a fire hazard rating not to exceed 25 for flame spread and 50 for smoke development, as tested by ASTM E-84, NFPA 255, and UL-723.

1.4 SUBMITTALS

- A. All submittals shall comply with Section 230500 – General HVAC Requirements.
- B. Provide product data on all insulation materials to be used. Indicate thicknesses to be used.

1.5 GENERAL REQUIREMENTS

- A. Code Compliance: Contractor shall insulate all systems with the materials and thicknesses as specified herein, but in no case shall the insulation be less than that required by the Washington State Energy Code (latest edition and amendments) or Energy Code enforced by the authority having jurisdiction. Contractor shall, in addition to insulating those systems/items specified herein, provide insulation where required by Code.
- B. Insulation at Hangers: Insulation shall be continuous through hangers on all insulated systems (except ductwork.) Inserts at hangers are specified and are considered as part of the hanger and support system. Inserts are required to be installed at the time of pipe installation and are intended to be installed by the Contractor installing the pipe hangers/supports.

PART 2 - PRODUCTS

2.1 ACCEPTABLE MANUFACTURERS

- A. Products shall comply with Section 230500 – General HVAC Requirements, Acceptable Manufacturers.
- B. Insulation: Manville, Armstrong, Owens-Corning, CSG, Knauf, Rubatex, Pittsburgh Corning, Imcoa, Halstead.

**KOPACHUCK STATE PARK
DAY USE DEVELOPEMENT**

- C. Accessories: Same as for insulation and Duro Dyne, Gustin Bacon, Childers, RPR, Tee Cee, J. P. Stevens, Buckaroos, Johnson.

2.2 DUCT INSULATION

- A. Fiberglass Insulation: 1.0 lb. per cubic foot minimum density; thermal conductivity no greater than 0.25 Btu-in/hr-sq. ft.-deg. F. at 75 degrees F with factory applied jacket as specified below.
- B. Fiberglass Insulation Jacket: Vapor proof jacket, consisting of aluminum foil cover with open mesh fiberglass, reinforcement, laminated to UL rated Kraft, vapor transmission rate shall not exceed 0.05 perms.
- C. Adhesive: Fire retardant, Duro Dyne type FPG or equal.
- D. Clips: Cement-on or welded-on pins impaled through glass fiber, with surface washers.
- E. Insulation Thickness:
 - 1. Supply Air Ductwork Within Building Space with Conditioned Air on Each Side of Space (e.g., mid-floor ceiling spaces, exposed duct): 1.0 inch thick.
 - 2. Supply Air Ductwork Within Building Space Without Conditioned Air on Each Side of Space (e.g., attic, crawl space, area between ceiling and roof): 2.0 inch thick.
 - 3. Supply Air Ductwork on Roof or Exterior of Building: Interior duct lining used-- specified in Section 233100 – Ductwork.
 - 4. Return Air Ductwork Within Building Space With Conditioned Air on Each Side of Space (e.g., mid-floor ceiling plenums): No insulation required.
 - 5. Return Air Ductwork Within Building Space Without Conditioned Air on Each Side of Space (e.g., attic, crawl space): 1.0 inch thick.
 - 6. Outdoor Air Intake Ductwork Within Building Space With Conditioned Air on Each Side of Space (e.g., ceiling plenums, exposed duct): 2.0 inch thick.
 - 7. Outdoor Air Intake Ductwork Within Building Space Without Conditioned Air on Each Side of Space (e.g., attic, crawl space): 1.0 inch thick.
 - 8. Exhaust Air Ductwork: 2.0 inch thick from point of exhaust airstream backdraft damper to outdoor termination.
 - 9. Alternative Insulation Thickness: Insulation thicknesses indicated are based on the thermal conductivities specified. Contractor at his option may use other insulation thicknesses for insulation with different thermal conductivities provided that the overall heat transfer coefficient is the same as if the specified insulation had been used. Submit calculations showing insulation equivalency for approval.

2.3 EQUIPMENT AND SPECIALTIES INSULATION

- A. Equipment: Insulation shall be same material as that specified for the HVAC system the equipment is installed in. Insulation thickness shall be 1.5 inches.
- B. Valves: All valves installed in insulated HVAC systems shall be insulated. Insulation material and thickness shall be same as that specified for the HVAC system the valve is installed in. Insulation shall be removable type on all control valves.
- C. Removable Insulation: Shall provide thermal insulating properties equivalent to that which is provided for HVAC system. Shall consist of 0.25-inch J. P. Stevens "Insulbatte" with glass cloth jacket, 4.0-inch Owens-Corning thermal insulating wool, Type II, fastened with No. 304 stainless steel hooks tied with 0.040-inch soft solid annealed copper wire. Where metal jacketing is

**KOPACHUCK STATE PARK
DAY USE DEVELOPEMENT**

required, provide with removable enclosures, of same material as metal jacketing, configured to suit items covered.

PART 3 - EXECUTION

3.1 GENERAL

- A. Equipment and Floor Protection: Cover existing equipment and finished floors to protect such items from insulation fiber and dust. Keep all such existing areas in a "broom clean" condition at the end of each day. Take precautions in these areas to prevent glass fiber and insulation dust from entering existing ventilating systems.
- B. Glass Fiber Insulation:
 - 1. Finish all insulation ends, no raw edges allowed.
 - 2. Joints: Tightly butt adjacent insulation sections together without any voids. Provide overlap of jacket material over all circumferential joints.
- C. Insulation Thickness: See "Part 2 - Products" for insulation thicknesses.
- D. Items To Be Insulated: Provide insulation on all ductwork, and all items installed in these duct systems, all energy conveying, all energy storage, and all energy consuming devices specified as part of Division 23, except where such insulation has been specifically excluded.
- E. Items Excluded From Being Insulated:
 - 1. Electric motors.
 - 2. Factory insulated or factory lined HVAC units.
 - 3. Fans.
 - 4. Internally lined ductwork.

3.2 DUCT INSULATION INSTALLATION

- A. Insulate all ducts with specified thickness.
- B. Insulation shall be firmly butted at all joints with a maximum allowable compression of 25%. All seams shall overlap a minimum of 2 inches and be finished with appropriate pressure sensitive tape or glass fabric and vapor retardant mastic. Pressure sensitive tapes and glass cloth shall be a minimum 3 inches wide.
- C. For rectangular ducts over 18 inches wide, duct wrap shall be additionally secured to the bottom of the ductwork with mechanical fasteners on 18 inch centers to reduce sagging. Washers shall be applied without compressing the insulation. All seams, joints, penetrations, and damage to the facing shall be sealed with vapor retardant mastic.
- D. Inside duct lining shall be as specified in Section 230700 – HVAC Insulation.
- E. All HVAC supply and outdoor air ducts shall be covered with glass fiber insulation. Where duct lining is used, the insulating properties of the lining may be credited toward meeting the R value specified for insulation.

**KOPACHUCK STATE PARK
DAY USE DEVELOPEMENT**

3.3 EQUIPMENT AND SPECIALTIES INSTALLATION

- A. All equipment where access is required shall have insulation installed so that it can be easily removed and reinstalled without requiring new insulation. Items requiring such removable insulation include, but are not limited to, the following:
 - 1. Control Valves.
 - 2. Strainers.
 - 3. Balancing Devices.
 - 4. Pressure/Temperature/Flow Measuring Devices.

- B. Specialties Requiring Insulation: All items connected in an insulated HVAC system shall be insulated, except the following:
 - 1. Factory Insulated Items.
 - 2. Diffusers & Grilles.

END OF SECTION 230700

**KOPACHUCK STATE PARK
DAY USE DEVELOPEMENT**

SECTION 230900 – CONTROL SYSTEMS (BUILDINGS)

PART 1 - GENERAL

1.1 WORK INCLUDED

- A. Control System Design.
- B. Complete system of automatic heating, ventilating, and air conditioning controls.
- C. Control devices, components, and wiring.
- D. Testing and adjustment.
- E. Operator Training.

1.2 DEFINITIONS

- A. "Conventional control components" means "control valves, dampers, actuators, wiring, air compressors, and other control devices that are not microprocessor based."

1.3 SUBMITTALS

- A. Shall comply with Section 230500 - General HVAC Requirements.
- B. Submit a complete list of equipment to be furnished, including product information for each item on the material list. Submit samples of wall sensor and bypass switch.
- C. Submit a complete set of shop drawings prior to installation containing the following information: interconnect drawings showing all wiring and control connections, control panel locations, all control device locations, arrangement of devices in panels, sequence of operation for all equipment, ladder diagrams showing switching functions of system and programs, logical outline of intended programs, building floor plans with all proposed thermostatic and other control device locations shown.
- D. Submit list of proposed component labeling.
- E. Record Drawings: See Section 230500 – General HVAC Requirements.
- F. Operation and Maintenance Manuals: See Section 230500 – General HVAC Requirements. In addition to the information required by that Section, provide (for inclusion in mechanical O&M Manual) the following:
 - 1. System description and complete sequence of operation.
 - 2. Reduced size (11" x 17") copies of as-built red line drawings.
 - 3. Input/Output (I/O) summary forms for the system listing all connected analog and binary input and output functions and the number types of all points.
 - 4. Description of unique devices/controls/programs specific to this system.
- G. Programmers Manuals: Provide manufacturer's programming manuals to Owner.

1.4 GENERAL REQUIREMENTS

- A. The entire control system shall be installed by skilled electricians and mechanics, all of whom are properly trained and qualified for the work they perform.

**KOPACHUCK STATE PARK
DAY USE DEVELOPEMENT**

- B. One single Contractor shall be responsible to design, furnish and install the complete building controls. Any subcontracted installation work shall be done by Contractors experienced and qualified in the work they perform subject to approval by the Engineer. Submit names(s) of proposed subcontractor(s) who will perform control work and extent of the work they will perform.

1.5 SPARE PARTS AND SPECIAL TOOLS

- A. Spare Parts: Provide one spare room temperature sensor and of the type installed.

1.6 WARRANTY AND SERVICE

- A. Warranty: After completion of the installation of the control system and acceptance by the Owner, the system shall be warranted as free against defects in manufacturing, programming, workmanship and materials for a period of one year from date of acceptance. In addition, the system shall be warranted to provide the sequence of operation and basic features specified, with the accuracy and flexibility also specified. The system shall be repaired or replaced, including materials and labor, if in owner's reasonable opinion, system is other than as warranted. Preventive and emergency maintenance shall be included.
- B. End of Warranty Service: At the end of the warranty period, the Contractor shall provide a re-check of the entire system operation, including calibration testing of a sample number of components and providing any necessary control adjustments for proper system operation. Such work shall be for a minimum of 4 man-hours.

PART 2 - PRODUCTS

2.1 ACCEPTABLE MANUFACTURERS

- A. Products shall comply with Section 230500 - General HVAC Requirements, Acceptable Manufacturers.
- B. Programmable thermostats and digital control by the heat pump equipment manufacturer.
- C. Conventional Control Components and Accessories:
 - 1. Products shall comply with Section 230500 - General HVAC Requirements, Acceptable Manufacturers.
 - 2. Control Components: Seimens, Seibe, Honeywell.
 - 3. Control Accessories: Idec, Hoffman, McDonnell, Tridelta, Edwards, Mamac, APC, Barksdale, Mark-Time, and manufacturers listed for Control Components.
 - 4. Control Components factory supplied with equipment specified are acceptable if capable of meeting performance and operation requirements.

2.2 BASIC SYSTEM

- A. The system shall be programmable thermostats with added features for door switches, timeclock functions, occupancy sensors, and similar functions.

**KOPACHUCK STATE PARK
DAY USE DEVELOPEMENT**

2.3 ACTUATORS

- A. Actuators shall be heavy duty reversible type, with driving motor and gear train and sealed in die cast case. Proportional actuators shall have a built-in electro-mechanical system to provide for positive repeatability of position, regardless of changes in output load. Belimo only.
- B. Actuator shall be proportional or two position type, as required for application. Actuator power and torque shall be sufficient to match dampers or valves being controlled and allow proper damper and valve operation against system pressures liable to be encountered. Actuator shall be capable of driving dampers from full closed to full open in less than 15 seconds.
- C. Units shall be complete with all linkages, brackets, and hardware required for mounting and to allow for the proper control of the regulated damper or valve.
- D. Actuator shall spring return upon power interruption to allow controlled devices to "fail safe" in open or closed position as dictated by freeze, fire or temperature protection requirements.

2.4 LOCAL TIMERS

- A. Interval Timer: 4 hour (unless specified longer) spring operated interval timer with wall plate indicating timer setting, and control knob. Timers shall not have a permanent HOLD position.

2.5 ACCESSORIES

- A. Wiring and Conduit: Shall comply with Division 26 specifications. Wiring that performs code required life safety shutdown of equipment or fire alarm interface shall comply with NFPA and local codes for fire alarm system wiring.
- B. Control Cabinet: Wall mounted, NEMA Type 1 construction, UL listed minimum 14 gauge sheet metal, hinged front door with latch. Size as required to house controls. Controls/devices shall be logically assembled in cabinet, with all devices and cabinet labeled.
- C. Relays: See paragraph "Contactors".
- D. Contactors: Shall be the single coil electrically operated, mechanically held type. Positive locking shall be obtained without the use of hooks, latches, or semi-permanent magnets. Contacts shall be doubled break silver to silver type protected by arching contact where necessary. Number of contacts and rating shall be selected for the application intended. Operating and release times shall be 100 milliseconds or less. Contractors shall be equipped with coil transient suppression devices to limit transients to 150% of rated coil voltage.
- E. Thermowells: Bronze or brass with NPT threads, sized to match device used with. All wells to be installed by Mechanical Contractor.
- F. Flow Switch: Brass constructed paddle flow type switch for installation in pipe tee, with SPDT switch, adjustable sensitivity, and multiple paddles.
- G. Miscellaneous Sensors/Transmitters/Switches/Transformers: Shall be manufacturer's standard, designed for application in commercial building HVAC control systems, compatible with other components so as to provide sequence of operation specified.

2.6 SWITCHES

- A. Air Flow Switches: General Purpose utilizing differential air pressure, SPDT snap-acting contacts, adjustable 0.1in. W.C. to 2.0 in. (minimum), neoprene diaphragm, all aluminum construction.

**KOPACHUCK STATE PARK
DAY USE DEVELOPEMENT**

- B. Water Flow Switches: General purpose liquid flow switch, SPDT snap-acting contacts, adjustable, neoprene diaphragm, in a dust tight enclosure, rated 150 psig and 250F.
- C. Damper End Switches: Shall be momentary type limit switches for monitoring the motion of the damper at a prescribed arc of rotation. The switch shall be hermetically sealed mercury contacts that operate by way of a trip lever. The switch shall be mounted on the exterior of the duct so that the trip lever is aligned with the damper vane. Mechanical adjustments in the switch case shall permit the proper lever action for tripping the mercury switch contacts. The switch shall have a SPDT contact arrangement that exceeds the load requirements for both voltage and current.
- D. Pressure to Electric Switches (PE): Shall sense a gradual control air pressure change and provide a snap action SPDT contact output. The setpoint shall be adjustable from 3 to 25 PSIG with a fixed differential of 2 PSI. The PE switch shall be suitable for both line and low voltage control applications and be listed by UL for electrical safety.
- E. Bypass Switch: Shall be momentary contact type push button. Install in standard wall box with stainless steel cover.
- F. Wall On/Off Switch: Standard wall box type switch, single pole, with illuminated switch for when controlled item is on. Provide with stainless steel wall plate, labeled as to function. Leviton or approved.
- G. 3-Position Wall Switch: Standard wall box type switch, with center off position, pole and throw to suit application. Provide with >036 stainless steel wall plate engraved as to function and each switch position. Arrow-Hart No. 4356, 4357, 4361, 4371, or equal.
- H. Door Sensor: Magnetic door status sensor for overhead coiling doors. Epoxy sealed in a metal housing. Magnet mounts on door. Sensor is hard wired.

PART 3 - EXECUTION

3.1 INSTALLATION

- A. Provide all computer software and hardware, operator input/output devices, sensors, relays, switches, dampers, actuators, conduit, tubing, wiring, motor starters and all other devices required to provide a complete integrated system with the sequence of operation and basic system features as specified.
- B. Room thermostats shall be mounted 4'-0" above finished floor unless indicated otherwise. Thermostats shall connect to the HVAC or fan unit serving the space the thermostat is located in, unless indicated otherwise. Not all thermostats are shown on the drawings and those shown are preliminary only. Contractor shall indicate all final thermostat locations on submittal drawings. Contractor is responsible to coordinate locations to avoid chalkboards, tackboards, and other interferences.
- C. It shall be the responsibility of this Contractor to provide power for all damper motors, time clocks, and other control devices requiring power. Coordinate with the Division 26 Contractor to arrange for necessary power circuits. Circuits have been made available in various electrical panels for this purpose (see electrical drawings/panel schedules).
- D. Provide all electrical wiring and devices in accordance with applicable National, State and local codes. All wiring shall be installed in conduit and in accordance with electrical section of these specifications, except that low voltage wiring within the ceiling plenum spaces and in mechanical platform area may be ran without conduit provided that plenum rated cable is used. Install all conduit and wiring parallel to building lines.

**KOPACHUCK STATE PARK
DAY USE DEVELOPEMENT**

- E. Component Labeling: All control components, except regular room thermostats, shall be equipped with name plates to identify each control component. Components in finished rooms shall be labeled as to generic item controlled for better user understanding; other devices shall be labeled with the same designation which appears on the Control Diagrams. Contractor shall submit list of proposed labeling prior to installing.
- F. Interlocks, where required, may be accomplished by COS rather than field hard wired relays or other devices.
- G. All devices which indicate on/off status to COS, shall have this on/off status manually or automatically controlled from COS, and shall have positive proof of on or off by differential pressure switch or other applicable device. Fans serving grease ducts or other system where duct pressure sensors may be subject to adverse conditions shall use current sensor with proper activation setpoints or equal device to indicate proper fan operation.
- H. Thermostat setpoints (all adjustable) shall be as follows unless indicated otherwise:

Occupied Heating	72 degrees F
Unoccupied Heating	75 degrees F
- I. Motor Starters: Control contractor shall provide all necessary motor starters and motor starting relays to allow proper control of the items listed herein where such starters/relays have not been specifically shown on the electrical drawings. Such starters/relays provided shall comply with the applicable Division 16 specifications, NEC, and governing code requirements. It is the general intent of the project documents that motor starting devices for motors 3/4 HP and smaller be provided by the Control Contractor, except where specifically shown.

3.2 SEQUENCE OF OPERATION

- A. Provide complete system with sequences of operation as indicated on drawings.
- B. Time Control: Central time clock shall provide occupied/unoccupied mode switching for all items indicated as having time clock control.
- C. Warm-up Control: Central optimum-start controls shall provide warm-up switching for all items indicated as having a warm-up cycle.
- D. Schedules: Provide independent occupied/unoccupied mode schedules and optimum start (i.e., warm-up) cycles for each heat pump, all fans indicated as having "time clock" control (see Fan Schedule), kiln operation, and domestic circulating pumps.
- E. All setpoints and differentials shall be adjustable. All DDC systems shall use proportional-integral control action.
- F. Provide all actuators and other devices for all equipment where such actuators or related devices are not specified as being furnished by the equipment manufacturer.
- G. Various thermostats are not shown on the drawings but are required per the sequence of operation specified. Coordinate with Engineer for location of all such thermostats prior to installing.
- H. Provide all control devices and connections to allow hand-off-auto control of all units from units' motor starters and motor control centers.
- I. Provide all motor rated relays and/or motor starters as required to allow for automatic control as specified herein where such devices have not been provided by others.

END OF SECTION 230900

**KOPACHUCK STATE PARK
DAY USE DEVELOPMENT**

SECTION 231123 – PROPANE GAS PIPING

PART 1 – GENERAL

1.1 WORK INCLUDED

- A. Propane Gas Piping.

1.2 SUBMITTALS

- A. Submittals shall comply with Section 230500.
- B. Submit product information on all items to be used.

PART 2 - PRODUCTS

2.1 ACCEPTABLE MANUFACTURERS

- A. Products shall comply with Section 230500, Acceptable Manufacturers.
- B. Steel Pipe and Fittings: U.S. Steel, Bethlehem, Walworth, Flagg, Grinnell, Felker.
- C. Valves: Milwaukee, Powell, Nordstrom, Walwork, Stockham, Red-White, Hammond, Apollo, Nibco.

2.2 PROPANE GAS PIPE AND FITTINGS

- A. Pipe and fitting standards shall be seamless or welded schedule 40 steel pipe per ANSI/ASTM A120.
- B. Underground Piping: Schedule 40, factory wrapped steel piping with welded joints using butt-welding fittings. Factory wrapped pipe shall consist of factory applied adhesive undercoat and continuously extruded polyethylene coating. Field wrap fittings, couplings, and damaged areas of coating with two wraps of overlapping 10 mil thick polyethylene tape.
- C. Aboveground Piping: Schedule 40, black steel piping:
 - 1. 2 Inch and Less, Exposed: Threaded joints with malleable iron fittings.

2.3 PROPANE GAS SYSTEM VALVES

- A. General: Valves shall be intended for use on propane gas system and suitable for the pressures and temperatures likely to be encountered.
- B. Ball Valves (2 Inch and Smaller): Bronze body valve, with threaded ends, full port, stainless steel disc and stem, 175 psi working pressure, UL listed for use with fuel gases, and AGA design certified for natural gas.

2.4 PROPANE GAS SYSTEM ACCESSORIES

- A. Gas Regulator: Cast iron body, die cast aluminum alloy diaphragm case, Buna-N-Diaphragm disc, union nut connection, and having positive tight lock-up. Regulator shall

**KOPACHUCK STATE PARK
DAY USE DEVELOPMENT**

be sized by manufacturer based on inlet pressure, desired outlet pressure, and flow requirements. Rockwell 143-80 or approved.

PART 3 - EXECUTION

3.01 INSTALLATION

- A. Provide all piping, fittings, and components as shown on the drawings and specified to provide complete and operational gas piping systems.
- B. Install all exposed piping parallel to the closest wall and in a neat, workmanlike manner.
- C. Do not run any piping above electrical panels (and similar electrical equipment). Provide offsets around such panels as necessary.
- D. Threaded Connections: Cut piping carefully, ream, thread and work into place without springing. Use teflon tape or lead and graphite lubricant--on male threads only.
- E. Install in accordance with gas company regulations, local codes and ordinances, and the Uniform Mechanical Code.
- F. Provide shutoff valves and drip leg in gas piping inlet to all equipment, and where shown.
- G. Pipe regulator vent lines full size to outside of building; terminate with screened vent cap (Clay & Bailey CB-300). Vent piping shall be same as that specified for gas piping.
- H. Testing: All gas piping shall be tested with 150 psi air for a period of 24 hours without pressure drop (after compensating for any temperature changes). All mechanical joints and fittings shall be soap tested to detect leakage.

END OF SECTION 231123

**KOPACHUCK STATE PARK
DAY USE DEVELOPEMENT**

SECTION 233100 – DUCTWORK

PART 1 - GENERAL

1.1 WORK INCLUDED

- A. Environmental Ductwork Systems.
- B. Acoustical Duct Lining.
- C. Pre-Installation Conference.
- D. Duct Cleaning and Testing.
- E. Duct Shop Drawings.

1.2 DEFINITIONS

- A. Duct Sizes: All duct dimensions shown are inside clear dimensions. Where inside duct lining is specified or indicated, duct dimensions are to the inside face of lining.
- B. Low Pressure System: Velocities less than 2,000 fpm and static pressure in duct 2 inches w.g. or less.
- C. Gauges: Steel sheet and wire are U.S. Standard Gauge; aluminum sheet is Brown and Sharpe Gauge.

1.3 QUALITY ASSURANCE

- A. Fabricate and install ductwork in accordance with SMACNA duct construction publications and ASHRAE handbooks.
- B. Materials and installations shall comply with NFPA 90A, NFPA 90B, and the UMC.

1.4 SUBMITTALS

- A. Submittals shall comply with Section 230500 – General HVAC Requirements.
- B. Submit shop drawings for all HVAC ductwork which is to be installed differently than as shown on the drawings.

1.5 DUCT PRESSURE CLASS

- A. All ductwork shall be constructed to the static pressure indicated by the fan which serves the ductwork, or to 1-inch (plus or minus as appropriate), whichever is higher.

1.6 PRE-INSTALLATION CONFERENCE

- A. General: A pre-installation conference shall be held prior to the Contractor installing any of the materials of this section. The conference shall occur after all submittals have been satisfactorily reviewed by the Architect/Engineer and returned to the Contractor, and approximately 14 days prior to the proposed system installation date and prior to the fabrication of any system piping components. The purpose of this conference is to review the Contractors installation methods, materials, schedule, safety, coordination with all other trades, and related construction/design issues to allow for efficient and proper construction. The Architect/Engineer and Owner will

KOPACHUCK STATE PARK DAY USE DEVELOPEMENT

highlight various items of concern, typical problems encountered on similar projects, coordination issues, and related items.

- B. Attendance: The pre-installation conference shall be attended by the General Contractor, the Contractor doing the work of this Section, other contractor trades as appropriate to the proper coordination of the work of this section, the Owner's Representatives (at their option), the Engineer, and the Architect.
- C. Coordination: The Contractor shall notify the Architect of the Contractor's readiness to hold the pre-installation conference at least 14 days prior to the proposed meeting time, and mutually agreed upon meeting times arranged.

1.7 REFERENCES

- A. SMACNA HVAC Duct Construction Standards, Ccurrent Edition.
- B. SMACNA Duct Liner Application Standard, Current Edition.
- C. NFPA 90A: Standard for the Installation of Air Conditioning and Ventilating Systems.
- D. NFPA 90B: Standard for the Installation of Warm Air Heating and Air Conditioning Systems.
- E. UMC: Uniform Mechanical Code.

PART 2 - PRODUCTS

2.1 ACCEPTABLE MANUFACTURERS

- A. Products shall comply with Section 230500 - General HVAC Requirements, Acceptable Manufacturers.
- B. Sheet Metal: All domestic manufacturers.
- C. Spin-in Fittings: General Environment Corp., Clevepak Corp.
- D. Duct Sealant and Tape: Durkee-Atwood, Hardcast, Duro-Dyne, Benjamin Foster, Products Research, Chemical Corp, and Ductwork.

2.2 GENERAL MATERIALS

- A. Ducts: Construct of galvanized sheet steel, suitable for lock forming without flaking or cracking, conforming to ASTM A527, having a zinc coating of 1.25 ounces total per square foot for both sides of a sheet, corresponding to coating designation G90 per ASTM A525.
- B. Fasteners: Use rivets and bolts throughout; sheet metal screws are acceptable on low pressure ductwork only.
- C. Spin-in Fittings: Factory fabricated of galvanized steel, bell-shaped, with die-formed mounting groove and damper. Provide 45 degree extractor when the spin-in fitting is installed in a duct which has a width of 12 inches or more. General Environmental Model SM-1D or SM-1 DEL.
- D. Duct Sealant: Shall be fire resistant with a flame spread rating of 25 or less, and a smoke developed rating of 50 or less. Sealant shall also be water resistant and compatible with mating

KOPACHUCK STATE PARK DAY USE DEVELOPEMENT

materials and types of joints or connections being sealed, specifically made for sealing ducts. Exterior duct sealant shall be specifically intended for outdoor use as a duct sealant.

- E. Duct Tape: Shall be fire resistant with a flame spread rating of 25 or less, and a smoke developed rating of 50 or less. Tape used shall be specifically compounded for maximum adhesion to galvanized steel, and shall be compatible with the duct sealant used.

2.3 LOW PRESSURE DUCT FABRICATION

- A. Duct Gauge and Reinforcement: Shall be as shown in SMACNA HVAC Duct Construction Standards according to the pressure classification of the system and the duct dimensions.
- B. Joints and Seams: Construct in accordance with SMACNA HVAC Duct Construction Standards. Leakage shall be less than 5% of total system airflow. Button punch or bolt connections in standing seams shall be spaced on centers not greater than 6" apart. Coordinate joint spacing with duct reinforcement requirements so that transverse joints having the required stiffness may be incorporated in the reinforcement spacing schedule.
- C. Elbows and Tees: Shall be long-radius type with a center-line radius not less than 1-1/2 times the width or diameter of the duct. Where space does not permit the use of long-radius elbows, short-radius or square elbows with turning vanes shall be used.
- D. Transitions: Increase duct sizes gradually. Transitions for diverging air flow shall be made with each side pitched out not more than 20 degrees. Transitions for converging air flow shall be made with each side pitched in not more than 30 degrees.
- E. Branch Connections: Duct take-offs from rectangular ductwork to round ductwork shall be made using spin-in fittings (unless a different fitting type is specifically shown). Duct take-offs from rectangular duct to rectangular duct shall be as shown on the drawings and in compliance with SMACNA Standards.
- F. Ductmate Systems: Transverse duct joints may be made with Ductmate System, or approved equal. System shall consist of companion flanges of 20 gauge galvanized steel with an integral polymer mastic seal; corner pieces of 12 gauge G90 galvanized steel; 20 gauge G90 galvanized cleats; closed cell, high density gasket type; and galvanized carriage bolts with hex nuts. The flanges shall be securely fastened to the duct walls using self-drilling screws, rivets or spot welding. Fastener spacing shall be as recommended by the manufacturer for the size of duct and the pressure class. The raw duct ends shall be properly seated in the integral mastic seal. A continuous strip of gasket tape, size 1/4" x 3/4", shall be installed between the mating flanges of the companion angles at each transverse joint; and the joint shall be made up using 3/8-inch diameter x 1-inch long plated bolts and nuts. Galvanized drive-on or snap-on cleats shall be used at spacings as recommended by the manufacturer.

2.4 DUCT LINING

- A. Material: Flexible, inorganic glass fiber material, maximum thermal conductivity of 0.26 Btu-inch/hr-sq. ft.-degree F at 75 degrees F, coated to prevent erosion, and conforming to SMACNA Duct Liner Application Standard. Lining shall be 1-inch thick on ductwork within the building and 2-inch thick on ductwork exterior of the building.
- B. Adhesives: Fire resistant, Type 1, conforming to the Standard for Adhesives for Duct Liner, ASC-A-7001C-1972, of the Adhesive and Sealant Council, as contained in the SMACNA Duct Liner Application Standard.

**KOPACHUCK STATE PARK
DAY USE DEVELOPEMENT**

- C. Mechanical Fasteners: Shall conform to the Mechanical Fasteners Standard, MF-1-1975, as contained in the SMACNA Duct Liner Application Standard.

PART 3 - EXECUTION

3.1 SHOP DRAWINGS

- A. Shop drawings of all ductwork are required. Contractor shall field locate existing building features that may interfere with new ductwork. See Section 230500 – General HVAC Requirements, for drawing requirements.
- B. Contractor shall include in his bid a minimum of 4 hours per room for the creation of shop drawings.

3.2 DUCTWORK INSTALLATION

- A. Install all ductwork and plenums in sizes and locations as shown on the drawings, complete with all accessories and connections to provide complete and operable heating, ventilating, air conditioning, and exhaust systems.
- B. Ducts shall be installed level and in neat lines with the building construction.
- C. All ducts are to be installed concealed unless indicated otherwise.
- D. Apply a bead of duct sealant to all spin-in fittings where fitting seals against sheet metal duct.
- E. Seal all joints in accordance with Seal Classification as shown in Table 1-2 of the SMACNA HVAC Duct Construction Standards. All "Ductmate" and similar systems shall be installed in strict accordance with manufacturer's instructions.
- F. In addition to applying sealant to joints in accordance with the SMACNA requirements, all joint corners and seams shall be sealed and all joints and seams shall be taped over with minimum 3-inch wide duct tape. Such tape is not required on exposed ducts, but all joint corners shall have adhesive applied. Exposed ducts shall be carefully sealed to maintain good appearance.
- G. Alternative Duct Sizes: The Contractor, at his option, may use duct sizes other than those shown on the drawings, provided that the Architect/Engineer gives prior approval, and the pressure drop per lineal foot of the proposed duct does not exceed that for the duct shown.

3.3 DUCT CLEANING AND TESTING

- A. All ducts shall be wiped or blown clean of all dust and debris prior to the installation of grilles or diffusers.
- B. All existing ducts that are to be reused shall be brushed and vacuumed clean of all internal dust and debris.
- C. All plenums shall be vacuum cleaned of all dust and debris prior to system operation.

END OF SECTION 233100

**KOPACHUCK STATE PARK
DAY USE DEVELOPMENT**

SECTION 233300 – AIR DUCT ACCESSORIES

PART 1 - GENERAL

1.1 WORK INCLUDED

- A. Flexible Connections
- B. Manual Dampers

PART 2 - PRODUCTS

2.1 ACCEPTABLE MANUFACTURERS

- A. Products shall comply with Section 230500 – General HVAC Requirements, Acceptable Manufacturers.

2.2 FLEXIBLE CONNECTIONS

- A. Provide flexible connections at all duct connections to fans, where ducts of dissimilar metals are connected, and where shown on the drawings.
- B. For round ducts, the flexible material shall be secured by zinc-coated, iron clinch type draw bands.
- C. For rectangular ducts, the flexible material shall be locked to metal collars which shall be connected to the duct using normal duct seam construction methods.
- D. Install flexible connections with sufficient slack to permit 2 inches of horizontal or vertical movement of ducts or equipment at flexible connection point without stretching the flexible material.
- E. Where installed exposed to outside weather, provide a galvanized "hat" channel protecting top and vertical stretches of flexible connector from sunlight and weather.

2.3 MANUAL DAMPERS

- A. Dampers shall be fabricated of galvanized steel, two gages heavier than duct in which installed.
- B. Maximum blade width is 12 inches; fabricate multi-blade dampers with opposed blade pattern for ducts larger than 12" x 48".

**KOPACHUCK STATE PARK
DAY USE DEVELOPMENT**

- C. Damper regulator sets shall have quadrant dial regulator with locking nut, square end bearing one side, and spring round end bearing other side (small sizes) or open end square bearing (larger sizes), axis of blade the long dimension. Regulator sets shall be Duro-Dyne Model numbers as follows:

Max. Blade Dimension	Duro-Dyne Regulator Set	Shaft Size
10" and less	KS-145, 145L	1/4"
11" to 14"	KSR-195, 195L	3/8"
15" to 23"	SRS-388, SB-138, KP105	3/8"
24" and larger	SRS-128, SB-112, KP105	1/2"

- D. Multiple blade dampers shall have individual quadrants for each blade or one quadrant with interconnected blades.
- E. Flush-mounted concealed type damper quadrants shall have prime paint finish, and shall be Ventfabrics No. 666 or Young Regulator Co. No. 301.

PART 3 - EXECUTION

3.1 INSTALLATION

- A. Install roof hood at locations as shown on the drawings. Install hoods in accordance with Manufacturer's recommendations and instructions. Where hoods are not sized on drawings, select for maximum pressure drop of 0.5" at full flow.
- B. Install duct flexible connections at all duct connections to equipment. Installation shall not allow any "grounding" of vibrating machinery to ducts.
- C. Provide balancing dampers where shown and as required to perform balancing.
- D. Install turning vanes in all square duct turns.

END OF SECTION 233300

**KOPACHUCK STATE PARK
DAY USE DEVELOPEMENT**

SECTION 233400 – FANS

PART 1 - GENERAL

1.1 WORK INCLUDED

- A. Ceiling Exhaust Fans.
- B. High Volume Low Speed Ceiling Fans

1.2 QUALITY ASSURANCE

- A. Fans shall bear the AMCA certified seal unless indicated otherwise.

1.3 SUBMITTALS

- A. Submittals shall comply with Section 230500 – General HVAC Requirements.
- B. Submit fan curves showing SP vs. CFM and BHP vs. CFM with system operating point clearly marked.
- C. Submit sound power level data showing sound power levels in decibels referenced to 10 watts for each of the eight octave bands (not required for fans under 1500 CFM). Submit sound power levels in sones for fans under 1500 CFM (or decibel values if available).

PART 2 - PRODUCTS

2.1 ACCEPTABLE MANUFACTURERS

- A. Products shall comply with Section 230500 – General HVAC Requirements, Acceptable Manufacturers.
- B. Ceiling Exhaust Fans: Nutone, Cook, Greenheck, Acme, Penn.
- C. High Volume Low Speed Ceiling Fans: Big Ass Fans

2.2 GENERAL

- A. Motors: Shall be U.L. listed and as specified in Section 230500 – General HVAC Requirements. Motors shall have adjustable supports for adjusting belt tension. Provide explosion proof motors in accordance with NEC Class 1 group D standards where indicated on the drawings.
- B. Capacity: Fan capacity shall not be less than the values listed in the Fan Schedule on the drawings.
- C. Outlets and Inlets: Equipment shall be furnished with attachment angles and/or flanges as required for attaching ductwork flexible connections as shown on the drawings.
- D. Fan Types: The type of each fan is indicated on the Fan Schedule, under the "Type " column, and corresponds to the types specified herein.
- E. Fan Performance Ratings: Shall be based on laboratory tests conducted in accordance with AMCA Test Codes.
- F. Fan Arrangement and Drive: Shall be as shown on the drawings.

**KOPACHUCK STATE PARK
DAY USE DEVELOPEMENT**

- G. Electrical: Fan disconnects and motor starters shall comply with Division 26 specifications. Disconnects furnished with fan shall come factory wired to motor.
- H. Finish: All fans shall have factory applied enamel finish (manufacturer's standard color) over a rust inhibiting primer base coat.
- I. Backdraft Dampers: Provide all exhaust fans with backdraft dampers, constructed of aluminum or galvanized steel, having felt or neoprene lined edges. Shall be "butterfly" type where used on fans with round connections. Shall be installed in curb for roof top curb mounted type fans. Backdraft dampers not required for kitchen hood exhaust fans. Backdraft dampers shall be gravity type unless indicated to be motorized type.
- J. Weatherproof: Where installed exposed to weather, fans shall have weatherproof enclosure, preventing any wind driven water entry into unit or drive assembly.

2.3 CEILING EXHAUST FANS

- A. Type: In-line, centrifugal cabinet fan. NUTONE QTXEN or approved.
- B. Housing: Shall be constructed of galvanized steel, with inlet and outlet duct connection collars, spring-loaded discharge backdraft damper, adjustable mounting brackets for wall or ceiling mounting, and minimum 1/2" - 1-1/2 lb/cubic foot density fiberglass duct liner insulation. Fan shall have access panel allowing access to fan motor and scroll without disturbing fan housing, ductwork or wiring.
- C. Fan Wheel(s): Unit shall have forward curved centrifugal type fan wheels(s). Wheel(s) shall be statically and dynamically balanced. Provide twin fan wheels when indicated on the Fan Schedule or where required to provide capacity indicated.
- D. Drive: Fan shall be direct drive, with drive assembly mounted on vibration isolators.
- E. Accessories: Provide the following accessories where indicated on the Fan Schedule or shown on the drawings:
 - 1. Speed Controls: Solid state speed controller allowing speed reduction down to 50% of maximum.
 - 2. Disconnect: Factory mounted on side of cabinet or within unit but so as to be accessible when unit is installed. Disconnect shall consist of switch or receptacle and plug-in power cord assembly; no added field devices shall be needed.

2.4 HIGH VOLUME LOW SPEED CEILING FANS

- A. Complete Unit
 - 1. Regulatory Requirements: The entire fan assembly shall be NRTL-certified and built pursuant to the construction guidelines set forth by UL standard 507 and CSA standards 22.2 No. 60335-1 and 22.2 No. 113.
 - 2. Sustainability Characteristics: The fan shall be designed to move an effective amount of air for cooling and destratification of conditioned commercial applications over an extended life. The fan components shall be designed specifically for high volume, low speed fans to ensure lower operational noise. Sound levels from the fan operating at maximum speed measured in a laboratory setting shall not exceed 40 dBA. Actual results of sound measurements in the field may vary due to sound reflective surfaces and environmental conditions.
 - 3. Good workmanship shall be evident in all aspects of construction. Field balancing of the airfoils shall not be necessary.

**KOPACHUCK STATE PARK
DAY USE DEVELOPEMENT**

4. High volume, low speed (HVLS) fans shall be licensed to bear the AMCA Certified Rating Seal for Circulating Fan Performance to ensure performance as cataloged in the field. Unlicensed HVLS fans shall not be accepted.

B. Controls

1. The fan controller shall be incorporated into the fan assembly and housed in an enclosure independent of the motor to prevent overheating or electrical interference. The fan controller shall be factory programmed to minimize starting and braking torques and shall be equipped with a simple diagnostic program and an LED light to identify and relay faults in the system.

C. Airfoil System

1. The fan shall be equipped with eight (8) high volume, low speed airfoils of precision extruded, anodized aluminum alloy. Each airfoil shall be of the high-performance Mini-Elipto design. The airfoils shall be connected to the hub and interlocked with eight (8) stainless steel retainers and two (2) sets of stainless steel bolts and lock washers per airfoil.
2. The fan shall be equipped with eight (8) upswept winglets designed to redirect outward airflow downward, thereby enhancing efficiency. The winglets shall be molded of high strength polymer and shall be attached at the tip of each airfoil with a stainless steel screw. The standard color of the winglets shall be silver or black.
3. As an option, the fan shall be equipped with eight (8) plug-style airfoil tips, molded of high strength polymer, in place of the eight (8) upswept winglets. The airfoil tips shall be attached at the tip of each airfoil with a stainless steel screw. The standard color of the airfoil tips shall be black.

D. Motor

1. The motor shall be a permanent magnet brushless motor rated for continuous operation at maximum speed with the capability of modulating the fan speed from 0–100% without the use of a gearbox or other mechanical means of control.
2. The motor shall operate from any voltage ranging from 100–120 VAC or 200–240 VAC, single phase, and 50/60Hz, without requiring adapters or customer selection. The motor shall be a non-ventilated, heat sink design with the capability of continuous operation in -4°F to 131°F (-20°C to 55°C) ambient condition.
3. The motor shall be rated IP43.
4. The standard color of the motor unit shall be silver with black trim.

E. Mounting System

1. The fan mounting system shall be designed for quick and secure installation from a variety of structural supports. All components in the mounting system shall be of formed metal design using low-carbon steel no less than 3/16” (0.5 cm) thick and containing no critical welds. The mounting system shall be powder coated for appearance and resistance to corrosion. All mounting bolts shall be metric stainless steel or equivalent. No mounting hardware substitutions, including cast aluminum, are acceptable.
2. The fan extension tube shall be a round, extruded aluminum tube. The extension tube shall include a chrome plate with forward and reverse controls and a fan status indicator light that is visible from the floor.

**KOPACHUCK STATE PARK
DAY USE DEVELOPEMENT**

F. Hub

1. The fan hub shall be constructed of zinc plated steel for high strength and durability. The hub shall be precision machined to achieve a well-balanced and solid rotating assembly.

G. Safety Cable

1. The fan shall be equipped with a safety cable that provides an additional means of securing the fan assembly to the building structure. The safety cable shall be Ø3/16" (0.5 cm) diameter and fabricated out of 7 x 19 stranded galvanized steel, pre-loaded and tested to 3,200 lbf (13,345 N).
2. Field construction of safety cables is not permitted.

H. Wall Control

1. Wired (standard). The fan shall be equipped with a low-voltage wired remote wall control providing control of all fan functions. The wall control shall be capable of mounting to a standard electrical box. The wall control shall include a rotary-style dial for controlling the fan's power and speed and an LED light to identify and relay faults in the system. Communication with the fan drive and controller shall be by a standard, commercially available CAT5 (or higher) Ethernet cable that is field installed and provided by the installer.

PART 3 - EXECUTION

3.1 INSTALLATION

- A. Install fans at locations and as shown on the drawings.
- B. Install fans in accordance with Manufacturer's recommendations and instructions.
- C. Fans with solid state speed controllers shall have the speed controller mounted on the fan housing unless another location is indicated on the drawings (for use by Balancer).
- D. Provide flexible connections in ductwork connections to all fans.
- E. Roof top fans shall be mounted on curbs, secured to curb on all sides, and sealed watertight. Curbs shall be factory fabricated and furnished with fan, where so indicated.
- F. Install all fans with vibration isolators so that no sound or vibration is transmitted to the structure. See Section 230548 – HVAC Vibration and Seismic Control, for vibration isolation specifications.
- G. Prior to air balancing, check fans for correct rotation, tighten belts to proper tension, adjust fan rpm to value shown on drawings, and lubricate bearings per manufacturer's recommendations.

END OF SECTION 233400

**KOPACHUCK STATE PARK
DAY USE DEVELOPEMENT**

SECTION 233700 – AIR OUTLETS & INLETS

PART 1 - GENERAL

1.1 WORK INCLUDED

- A. Supply Outlets.
- B. Exhaust Inlets.
- C. Return Inlets.
- D. Louvers.
- E. Wall and Roof Caps.
- F. Roof Hoods and Vents.

1.2 REFERENCES

- A. SMACNA HVAC Duct Construction Standards, Current Edition.

1.3 SUBMITTALS

- A. Shall comply with Section 230500 – General HVAC Requirements.
- B. Submit product information on all items.

PART 2 - PRODUCTS

2.1 ACCEPTABLE MANUFACTURERS

- A. Products shall comply with Section 230500 – General HVAC Requirements.
- B. Diffusers, Grilles, Registers, and Door Louvers: Carnes, Anemostat, Titus, Metal-Aire, Krueger, J & J Register, Price, Tuttle & Bailey.
- C. Outside Louvers: Ruskin, American Warming and Ventilating, Air Balance, Penn, Dowco, Wonder-Metals, Vent Products.
- D. Door Louvers: IAC, Krueger, Metal-Aire, Ruskin.
- E. Door Roof Hoods and Vents: Pace, Penn, Greenheck, Carnes.
- F. Wall and Roof Caps: Greenheck, Penn, Nutone, Carnes.

2.2 GENERAL REQUIREMENTS

- A. Air outlets shall be of the size, type, and with number of throws as shown on the drawings; and shall match the appearance and performance of the manufacturers' models specified and scheduled on the drawings.
- B. Air outlet application shall be based on a noise level of NC 35 maximum.
- C. Furnish all necessary screws, clips, duct collars, and transitions required to allow for the air outlet installation and connection to ductwork.

**KOPACHUCK STATE PARK
DAY USE DEVELOPEMENT**

- D. Finish: Factory enamel finish, color as selected by Architect/Engineer, except that LSG type and any other wall inlets/outlets used in the same room/area as the LSG shall have brushed aluminum finish.
- E. Frame Style: Provide air outlets and inlets with frame style to match ceiling or wall construction installed in. Where supply air outlets or inlets are installed in T-bar ceiling systems, they shall be factory installed in 2' x 2' or 2' x 4' metal panel to match ceiling layout. Where installed against gypsum board surface, brick or similar hard surface or, where exposed, provide with 1-1/4" wide outer border. Where space does not permit installing 2' x 2' metal panel, provide outlets or inlets with 1-1/4" wide outer border. Where air outlets are installed adjacent to surface mounted light fixtures, outlets shall have 4-inch deep drop frames. (See reflected ceiling plan and/or electrical lighting plan for ceiling type and allowable space).
- F. Contractor shall measure actual louver wall openings prior to ordering or fabricating louvers. Notify Architect/Engineer of any discrepancy between actual wall opening and specified opening.
- G. Ceiling transfer grilles (TG) shall be same as CEG's unless specifically shown otherwise; wall transfer grilles (WTG) shall be same as WEG unless specifically shown otherwise.

2.3 SUPPLY AIR OUTLETS

- A. Ceiling Diffuser (CD): Ceiling diffusers shall be steel for fixed, horizontal discharge pattern. These diffusers shall consist of an outer frame assembly of the sizes and mounting types shown on the plans and outlet schedule. A square or rectangular inlet shall be an integral part of the frame assembly and a transition piece shall be available to facilitate attachment of round duct. An inner core assembly consisting of fixed deflection louvers shall be available in one-, two-, three- or four-way horizontal discharge patterns. The inner core assembly must be removable in the field without tools for easy installation, cleaning or damper adjustment. The finish shall be #26 white. The finish shall be an anodic acrylic paint, baked at 315°F for 30 minutes. The pencil hardness must be HB to H. The paint must pass a 100-hour ASTM B117 Corrosive Environments Salt Spray Test without creepage, blistering, or deterioration of film. The paint must pass a 250-hour ASTM D870 Water Immersion Test. The paint must also pass the ASTM D2794 Reverse Impact Cracking Test with a 50-inch pound force applied. The manufacturer shall provide published performance data for the diffuser. The diffuser shall be tested in accordance with ANSI/ASHRAE Standard 70-1991. TITUS Model TDC.
- B. Duct Supply Grille (DSG): Aluminum supply grilles shall be double deflection direct spiral duct-mounted supply grilles for the sizes and mounting types as shown on the plans and outlet schedule. The deflection blades shall be available parallel to the long or short dimension of the grille. All supply grilles shall be constructed with radius end caps and foam gaskets for a tight seal to the duct diameter. All supply grilles shall be constructed with a 1 3/8-inch wide border. Blades shall be constructed of heavy duty extruded aluminum and shall be spaced 3/4-inch apart. Blades shall extend completely through the side frame on each side to ensure stability throughout the complete cfm operating range of the grille. Blades shall be individually adjustable without loosening or rattling and shall be securely held in place with tension wire. (S&F: perforated face will have 3/16-inch holes on 1/4-inch staggered centers.) Optional air scoop damper/extractor (option ASD) shall be constructed of heavy duty aluminum. The ASD must be operable from the face with a screwdriver. The grille finish shall be #26 white. The finish shall be an anodic acrylic paint, baked at 315°F for 30 minutes. The pencil hardness must be HB to H. The paint must pass a 100-hour ASTM B117 Corrosive Environments Salt Spray Test without creepage, blistering or deterioration of film. The paint must pass a 250-hour ASTM D870 Water Immersion Test. The

**KOPACHUCK STATE PARK
DAY USE DEVELOPEMENT**

paint must also pass the ASTM D2794 Reverse Impact Cracking Test with a 50-inch pound force applied. The manufacturer shall provide published performance data for the grille. The grille shall be tested in accordance with ANSI/ASHRAE Standard 70-1991. TITUS S300FL.

2.4 RETURN AIR OUTLETS

- A. Ceiling Return Grille (CRG): Return grilles shall be the sizes and mounting types as shown on the plans and outlet schedule. Return grilles must provide a free area of at least 90%. Outer borders shall be constructed of heavy extruded aluminum with a thickness of 0.040-0.050 inch and shall have countersunk screw holes for a neat appearance. Border width shall be 1¼ inches on all sides and shall be interlocked at the four corners and mechanically staked to form a rigid frame. Choice of three sizes of aluminum grid: ½ x ½ x ½ inch, ½ x ½ x 1 inch, or 1 x 1 x 1 inch shall be available. Optional opposed-blade volume damper shall be constructed of heavy gauge steel or aluminum. Damper must be operable from the face of the grille. The grille finish shall be #26 white. The finish shall be an anodic acrylic paint, baked at 315°F for 30 minutes. The pencil hardness must be HB to H. The paint must pass a 100-hour ASTM B117 Corrosive Environments Salt Spray Test without creepage, blistering or deterioration of film. The paint must pass a 250-hour ASTM D870 Water Immersion Test. The paint must also pass the ASTM D2794 Reverse Impact Cracking Test with a 50-inch pound force applied. The manufacturer shall provide published performance data for the grille. The grille shall be tested in accordance with ANSI/ASHRAE Standard 70-1991. TITUS Model 50F.
- B. Wall Return Grille (WRG): Steel return bar grilles shall be the sizes and mounting types as shown on the plans and outlet schedule. The fixed deflection bars shall be available parallel to the long or short dimension of the grille. Construction shall be of steel with a 1¼-inch border width on all sides and a minimum border gauge thickness of 16; bars shall be 14-gauge steel. Bars shall be reinforced by perpendicular, steel support bars spaced on 6-inch maximum centers. Corners shall be welded with full penetration resistance welds with a reinforcing patch for extra strength. Screw holes shall be countersunk for a neat appearance. The grille finish shall be #26 white. The finish shall be an anodic acrylic paint, baked at 315° F for 30 minutes. The pencil hardness must be HB to H. The paint must pass a 100-hour ASTM B117 Corrosive Environments Salt Spray Test without creepage, blistering or deterioration of film. The paint must pass a 250-hour ASTM D870 Water Immersion Test. The paint must also pass the ASTM D2794 Reverse Impact Cracking Test with a 50-inch pound force applied. The manufacturer shall provide published performance data for the grille. The grille shall be tested in accordance with ANSI/ASHRAE Standard 70-1991. TITUS Model 33FL.

2.5 6-INCH DEEP LOUVERS--STEEL BLADES

- A. Type: High performance, 6" deep, stationary, drainable louvers. Ruskin Model L6375D or approved.
- B. Frame: 6" deep, constructed of minimum 0.090" 6063 extruded aluminum, with integral caulking slots and downspouts in jambs and mullions.
- C. Blades: Shall be constructed of minimum 18 gauge galvanized steel, at 37.5 degree angle on approximately 4 3/4" centers, with drain gutter.
- D. Bird Screen: Shall be constructed of 1/2" mesh, 19 gauge galvanized steel.
- E. Performance: Nominal free area of 55%, with pressure drop and water penetration equal to specified manufacturer's model.

**KOPACHUCK STATE PARK
DAY USE DEVELOPEMENT**

- F. Wind Loading: Louver shall incorporate structural supports required to withstand a wind load of 30 lb. per square foot.
- G. Finish: Provide with standard mill finish.

2.6 WALL CAPS

A. Non-Masonry Walls:

1. For Airflows of 250 cfm and Less: Wall caps shall be constructed of anodized aluminum, with bird screen and built-in backdraft damper, 10" wide x 3" high, Greenheck Model No. WL-10x3.
2. For Airflow of 251 cfm up to 500 cfm: Wall caps shall be constructed of anodized aluminum, with bird screen and built-in backdraft damper, 16" wide x 8" high, Greenheck Model No. WL-18x6.
3. For Airflows of 501 cfm up to 1000 cfm: Shall be 4" deep extruded louvers, drainable type. 24" wide x 16" high, Ruskin ELF375DX or approved.

2.7 MISCELLANEOUS

- A. Goosenecks: Shall be made of minimum 18 gauge galvanized steel, in accordance with SMACNA HVAC Duct Construction Standards, Figure 5-5, and as shown on the drawings.
- B. Screen: 1/2-inch mesh, constructed of either 0.051-inch aluminum wire or 19 gauge galvanized steel wire.

PART 3 - EXECUTION

3.1 INSTALLATION

- A. Install air outlets in locations shown on the drawings and conform with architectural features and lighting arrangements.
- B. Paint ductwork which is visible behind air inlets and outlets flat black.
- C. All outlets and inlets exposed to the weather shall be adequately flashed and installed in a manner to assure complete weatherproofness.
- D. Sealing and caulking of all outlets and inlets exposed to the weather shall conform to Division 7 requirements.
- E. Provide screened openings (SO) on all duct openings where indicated and where openings do not have grilles or registers.
- F. Furnish door louvers to the Division 8 Contractor, who will install the door louvers in the doors.
- G. Coordinate with the Division 9 Contractor for any necessary painting of air inlets/outlets/louvers/etc. prior to installation.

END OF SECTION 233700

**KOPACHUCK STATE PARK
DAY USE DEVELOPEMENT**

SECTION 237200 – ENERGY RECOVERY VENTILATORS

PART 1 - GENERAL

1.1 WORK INCLUDED

- A. Energy Recovery Ventilators.
- B. Installation.
- C. Start up.

1.2 DEFINITIONS

- A. "ESP" is defined to mean external static pressure, measured external to the units' duct connection collars but including a pressure drop for the units' filters and any added heating or cooling coils.

1.3 QUALITY ASSURANCE

- A. Units shall be UL listed and labeled.
- B. Units shall be rated in accordance with ARI standards.

1.4 SUBMITTALS

- A. Shall comply with Section 230500 – General HVAC Requirements.
- B. Provide complete product information submittals on all units; include performance capacities as a function of indoor and outdoor coil db/wb temperatures and indoor coil air flow rates; supplementary heater capacity; fan performance (cfm vs. esp); and information on all filters and accessories.

PART 2 - PRODUCTS

2.1 ACCEPTABLE MANUFACTURERS

- A. Energy Recovery Units: Mitsubishi, Daikin, LG.

2.2 ENERGY RECOVERY VENTILATOR

- A. The ERV unit shall be factory assembled, wired and run tested. Contained within the unit shall be all factory wiring, control circuit board and blowers with motors, filters, and insulated foam air guides. Each unit will have an automatic by-pass damper system for economic operation under certain conditions. The unit shall have factory installed control board with functions for local, remote, and optional control modes.

**KOPACHUCK STATE PARK
DAY USE DEVELOPEMENT**

B. Unit Cabinet:

1. The cabinet shall be fabricated of galvanized steel, and covered with polyurethane foam insulation as necessary with steel mounting points securely attached

C. Blowers:

1. The unit shall be furnished with two (2) direct drive centrifugal blowers running simultaneously supplying and extracting air at the same rate for balanced ventilation air flow.
2. The blower motors shall be a directly connected to the blower wheels and have permanently lubricated bearings.
3. The blowers and motors shall be mounted for quiet operation.

D. Heat Exchanger

1. The heat exchanger element shall be constructed of specially treated cellulous fiber membrane separated by corrugated layers to allow total heat (sensible and latent) energy recovery from the exhaust air to the supply air or from the supply air to the exhaust air as determined by design conditions.
2. The element shall have protective filters installed at both the supply and exhaust sides with an access cover to allow easy maintenance.

E. Bypass Damper

1. The ERV shall have an automatic supply side by-pass damper to allow inbound ventilation air to by-pass the energy transfer core when outside weather conditions warrant.
2. The mechanism for opening and closing the bypass damper shall be a 208V-230V synchronous electric motor through an actuator. The motor will drive a steel cable connected to a mechanical damper flap to allow fresh air to bypass the element.
3. Supply and return air thermistor shall control the damper and may be interlocked with a remote controller.

F. Filter

1. The ERV shall be equipped with factory installed air filters located at each intake face (both supply and exhaust sides) of the core to clean the air and prevent clogging.

G. Mounting

1. Mounting of the ERV shall be as indicated in the plans and drawings. The ERV shall not require and condensate pan or receptacle nor condensate drain or piping. Mounting may be horizontal or vertical and the unit may be inverted as required by ductwork connection.

H. Electrical

1. The units will require a 208-230Volt, 1 Phase, 60Hz power supply.

**KOPACHUCK STATE PARK
DAY USE DEVELOPEMENT**

PART 3 - EXECUTION

3.1 INSTALLATION

- A. Install the heat recovery coil and heat recovery units as shown on the drawings and in accordance with manufacturer's instructions.
- B. Provide flexible connection at the duct connections to heat recovery coils in ducts, in accordance with the manufacturer's recommendations to allow for tilting of the coil.
- C. Provide flexible connections in ductwork connections to all units. Provide type complying with NFPA 96 on exhaust side of kitchen heat recovery units.
- D. All drains from plenums and drain pans shall be piped to the closest drain or as indicated on the drawings.
- E. The drawings show design configurations based on particular manufacturer's equipment. If contractor's selected manufacturer's equipment configured different from that which is shown, the Contractor shall provide all necessary modifications to ductwork, support systems, electrical requirements, and piping systems as required to accommodate furnished equipment at no additional cost to the Owner.
- F. Supplier shall include in bid, cost for changing sheaves on all fans to suit balancer and actual field requirements.

3.2 START UP

- A. Initial Checks: Prior to operating units, checks shall be made to insure that adequate voltage, plumbing connections (where applicable), duct connections, electrical connections, control connections, and other items as listed by the manufacturer are properly provided/connected and operating to insure safe and proper unit operation.
- B. Testing and Adjustment: Operate unit in various modes of operation to test for proper operation, including fan rotation, proper damper travel (where applicable), proper cooling/heating, correct interface to other controls (time clock, fans, etc.), coil temperature controls, etc. Tighten belts to proper tension, lubricate bearings, and make all other necessary adjustments, all per manufacturer's directions.
- C. Final Check: When the testing and adjustment is complete, a final check of each unit shall be done by the manufacturer's authorized service representative, or direct employee, to verify proper unit operation. Any defective items shall be repaired or replaced by the contractor until proper operation is confirmed by the manufacturer's authorized service representative.
- D. Written Report: When the final check has been completed, a written report from the manufacturer's authorized service representative shall be provided. This report shall list all units checked, items checked, check results, any items which may impair proper unit operation, and the name and phone number of the actual individual(s) doing the check. The report shall include a statement stating whether or not all units are operating as specified.

END OF SECTION 237200

**KOPACHUCK STATE PARK
DAY USE DEVELOPEMENT**

SECTION 237300 – HVAC EQUIPMNT

PART 1 - GENERAL

1.1 WORK INCLUDED

- A. Split System Heat Pump
- B. Electric Wall Heater

1.2 DEFINITIONS

- A. "ESP" means "External Static Pressure" and is defined to mean "The pressure drop due to airflow through all items external of the unit at standard conditions at the cfm scheduled."

1.3 QUALITY ASSURANCE

- A. Units shall be UL listed and labeled.
- B. Units shall be rated in accordance with ARI standards.
- C. Unit construction shall be designed to conform to ANSI/ASHRAE 15, NEC, Washington State Energy Code and applicable ASME codes.

1.4 REFERENCES

- A. ARI 270 - Standard for Sound Rating of Outdoor Unitary Equipment.

1.5 SUBMITTALS

- A. Shall comply with Section 230500 – General HVAC Requirements.
- B. Provide complete product information submittals on all units; include performance capacities as a function of indoor and outdoor coil db/wb temperatures and indoor coil air flow rates; supplementary heater capacity; fan performance (cfm vs. esp); and information on all filters and accessories.

PART 2 - PRODUCTS

2.1 ACCEPTABLE MANUFACTURERS

- A. Products shall comply with Section 23050- General HVAC Requirements, Acceptable Manufacturers.
- B. Split System Heat Pumps: Trane, Mitsubishi, Daikin
- C. Wall Heater: King, Cadet, Qmark

2.2 WALL MOUNTAIN SPLIT SYSTEM HEAT PUMP

**KOPACHUCK STATE PARK
DAY USE DEVELOPEMENT**

- A. General: The heat pump air conditioning system shall consist of a slim silhouette, compact, wall mounted indoor fan coil section with wireless remote controller and a slim silhouette horizontal discharge outdoor unit which shall be of an inverter driven heat pump design.
- B. Quality: The units shall be tested by a Nationally Recognized Testing Laboratory (NRTL) and shall bear the ETL label. All wiring shall be in accordance with the National Electrical Code (N.E.C.). The units shall be rated in accordance with Air-conditioning, Heating, and Refrigeration Institute's (AHRI) Standard 240 and bear the AHRI Certification label. The units shall be manufactured in a facility registered to ISO 9001 and ISO 14001, which is a set of standards applying to environmental protection set by the International Standard Organization (ISO). A dry air holding charge shall be provided in the indoor section. System efficiency shall meet or exceed 19 SEER when part of a 1:1 (indoor/outdoor) system.
- C. Warranty: The units shall have a manufacturer's parts and defects warranty for a period five (5) years from date of installation. The compressor shall have a warranty of seven (7) years from the same date of installation. If, during this period, any part should fail to function properly due to defects in workmanship or material, it shall be replaced or repaired at the discretion of the manufacturer. This warranty does not include labor.
- D. Performance: Each system shall perform in accordance with the ratings shown on the drawings.
- E. Indoor Unit:
1. General: The indoor unit shall be factory assembled, wired and run tested. Contained within the unit shall be all factory wiring, piping, control circuit board, fan and fan motor. The unit shall have a self-diagnostic function, 3-minute time delay mechanism, and an auto restart function after power interruption. Indoor unit shall be purged with dry air before shipment from factory.
 2. Unit Cabinet: The casing shall have a smooth front, white finish. Unit shall have multi directional drain connection and refrigerant piping, offering three (3) direction pipe alignments for all refrigerant piping and two (2) direction pipe alignments for condensate draining shall be standard. There shall be a separate, metal installation-plate that secures the indoor unit firmly to the wall. The installation-plate shall be securely attached to the wall using appropriate anchor method. Installing contractor shall determine the best method and be responsible for proper mounting of the installation plate to the wall.
 3. Fan: The indoor unit fan shall be an assembly with a line-flow fan direct driven by a single motor. The fan shall be statically and dynamically balanced and be powered by a motor with permanently lubricated bearing. Manual adjustable guide vanes shall be provided with the ability to change the airflow from side to side (left to right). An integral, motorized, multi-position, horizontal air sweep flow louver shall provide for uniform air distribution, up and down. Five (5) positions plus Auto and Swing shall be provided, controlled from the remote controller. Indoor unit sound shall not exceed 43 dB.
 4. Filter: Return air shall be filtered by means of easily removed, washable, Catechin, Antioxidant Pre-filter and an Anti-allergy enzyme filter – blue, pleated type.
 5. Coil: The indoor unit coil shall be of nonferrous construction with smooth plate fins on copper tubing. The tubing shall have inner grooves for high efficiency heat exchange. All tube joints shall be brazed with phos-copper or silver alloy. The coils shall be pressure tested at the factory. A sloped, corrosion resistant condensate pan with drain shall be provided under the coil. An optional drain pan level switch (DPLS1), designed to

**KOPACHUCK STATE PARK
DAY USE DEVELOPEMENT**

connect to the control board, shall be provided if required, and installed on the condensate pan to prevent condensate from overflowing.

6. Electrical: The unit electrical power shall be 208-230 volts, 1-phase, 60 hertz. The system shall be equipped with A-Control – a system directing that the indoor unit be powered directly from the outdoor unit using a 3-wire, 14-gauge AWG connection plus ground. The indoor unit shall not have any supplemental electrical heat elements.

F. Outdoor Units

- 1 General: The outdoor units are specifically designed to work with the indoor units. The outdoor units must have a thermally fused powder coated finish. The outdoor unit shall be completely factory assembled, piped and wired. Each unit shall be run tested at the factory.
2. Unit Cabinet: The casing shall be fabricated of galvanized steel, bonderized, finished with an electrostatically applied, thermally fused acrylic or polyester powder coating for corrosion protection. Assembly hardware shall be cadmium plated for weather resistance. Two (2) mild steel mounting feet, traverse mounted across the cabinet base pan, welded mount, providing four (4) slotted mounting holes shall be furnished. Assembly shall withstand lateral wind gust up to 155 MPH to meet applicable weather codes.
3. Fan: The unit shall be furnished with a direct drive propeller type fan. The outdoor unit fan motor shall be a direct current (DC) motor and have permanently lubricated bearings. The fan motor shall be mounted for quiet operation. The fan shall be provided with a raised guard to prevent contact with moving parts. The outdoor unit shall have horizontal discharge airflow.
4. Coil: The outdoor unit coil shall be of nonferrous construction with lanced or corrugated plate fins on copper tubing. The coil shall be protected with an integral metal guard. Refrigerant flow from the outdoor unit shall be regulated by means of an electronically controlled, precision, linear expansion valve. Outdoor unit shall be pre-charged with sufficient R-410a refrigerant for up to twenty-five (25) feet of refrigerant piping for capacities up to 18,000 BTU/h, and up to thirty-three (33) feet of refrigerant piping for capacities above 18,000 BTU/h. All refrigerant lines between outdoor and indoor units shall be of annealed, refrigeration grade copper tubing, ARC Type, meeting ASTM B280 requirements, individually insulated in twin-tube, flexible, closed-cell, CFC-free (ozone depletion potential of zero), elastomeric material for the insulation of refrigerant pipes and tubes with thermal conductivity equal to or better than 0.27 BTU-inch/hour per Sq Ft / °F, a water vapor transmission equal to or better than 0.08 Perm-inch and superior fire ratings such that insulation will not contribute significantly to fire and up to 1” thick insulation shall have a Flame-Spread Index of less than 25 and a Smoke-development Index of less than 50 as tested by ASTM E 84 and CAN / ULC S-102. All refrigerant connections between outdoor and indoor units shall be flare type. Coil shall have a coating for resistance to seacoast conditions.
5. Compressor: The compressor shall be a high performance, hermetic, inverter driven, variable speed, dual rotary type. The compressor motor shall be direct current (DC) type equipped with a factory supplied and installed inverter drive package. The outdoor unit shall be equipped with an accumulator. The compressor will be equipped with internal thermal overload protection. The outdoor unit must have the ability to operate over the full capacity range with a maximum height difference of 40 feet and have refrigerant tubing length of 65 feet for capacities up to 15,000 BTU/h and a maximum height difference of 50 feet and have refrigerant tubing length of 100 feet for capacities above 15,000 BTU/h between indoor and outdoor units. There shall be no need for line size

**KOPACHUCK STATE PARK
DAY USE DEVELOPEMENT**

changes. Filters, sight glasses, and traps shall not be used, and no additional refrigerant oil shall be required. The compressor shall be mounted so as to avoid the transmission of vibration.

6. Electrical: The outdoor unit electrical power supply shall be 208/230 volts, 1-phase, 60 hertz. The unit shall be capable of satisfactory operation within voltage limits of 187 volts to 253 volts. The outdoor unit shall be controlled by microprocessors located in the indoor unit and outdoor unit. A 12 to 24-volt DC data stream shall communicate between the units providing all necessary information for full function control.
7. Controls: The units shall use controls provided by the unit manufacturer to perform the function necessary to operate the unit. A touch screen interface shall be provided on the control panel to adjust all schedules and set points. The control panel shall communicate with and control the schedule of all heat pumps.

2.3 ELECTRIC WALL HEATER

- A. Heaters shall provide air movement at 85 CFM. Motor shall be shaded pole, permanently lubricated, C-frame type with impedance protection and sealed bearings. Motors shall be the same voltage as the heater. The motor and all wiring shall be totally isolated from the heating chamber for protection from heated air. The motor shall be equipped with a dynamically balanced four-blade aluminum impeller fan, located in the upper portion of the heat box, and shall provide a down-flow heating pattern. Assemblies shall be constructed of coiled Nickel Chromium alloy, corrosion-resistant wire strung through a minimum of four rows of mica insulator. Element assemblies shall have factory provided connection to allow field modification to 50% wattage at time of installation. Unit shall turn off during any unsafe temperature on the inlet or outlet. Wall can shall be 20 gauge electro-galvanized steel and contain knockouts through which power leads are brought. The wall can shall be able to mount directly to wall studs in new or existing construction. Wall can shall be provided with stud alignment tabs. Wall can shall be supplied with a factory installed ground wire. Grill shall be a louvered, one-piece design with rounded edges on all four sides, with rounded corners to prevent snags from contact with other materials. Grill shall be epoxy powder coated in color specified per architect.
- B. Controls: Provide programmable thermostats for each heater. Thermostats in public areas shall have a guard to prevent access.

2.4 REFRIGERATION PIPING

- A. ACR Type L copper tubing, with silver brazed joints and wrought copper fittings. Mechanical flared fittings may be used at connections to equipment.

PART 3 - EXECUTION

3.1 INSTALLATION

- A. Install all equipment at locations and as shown on the drawings.
- B. Install in strict accordance with manufacturer's instructions.
- C. Connect and install all items shipped loose with units.

3.2 LEAK TESTING AND EVACUATION

**KOPACHUCK STATE PARK
DAY USE DEVELOPEMENT**

- A. Connect a vacuum pump to the piping system and evacuate the system to 500 microns, and let stand for a minimum of 12 hours. If the vacuum reading remains unchanged, the system may be charged with refrigerant.

3.3 REFRIGERATION SYSTEM

- A. Install all refrigeration system components as recommended by the air conditioner manufacturer. At a minimum these shall include a site glass, service valves, expansion valves, and external filter/drier.

3.4 START-UP

- A. General: Start-up and subsequent system checks shall be done by the manufacturer's authorized service representative.
- B. Initial Checks: Prior to operating units, checks shall be made to insure that all equipment, piping, and controls are connected and operating properly. As a minimum, check for: proper voltage and phases, correct compressor oil level, valves open, correct electrical connections, complete control connections, overload heaters installed in compressor motor starter, hi and lo pressure cutouts properly set and connected, unit heaters operational, condenser fans rotating correctly, fans lubricated, coils clear of obstructions, and other items as listed by the manufacturer are properly provided/connected and operating to insure safe and proper unit operation.
- C. 72 Hour Checks: Provide checks in accordance with manufacturer's instructions; as a minimum review the following:
 - 1. Observe the compressor oil level. If low, operate the system for three to four hours, checking the oil level frequently. If it remains low, add oil.
 - 2. Check the refrigerant flow in the liquid line sight glass. The flow should be solid with no evidence of flash gas. If bubbles of flash gas appear, check the system for leaks; repair if necessary and add refrigerant.
 - 3. Check the temperature of the liquid line from the inlet of the filter-drier to the expansion valve. The temperature should be uniform. If a decided temperature difference exists across a valve or fitting, a restriction is evident. The restriction is causing a pressure drop which, in turn, is causing the refrigerant to flash. Such a pressure drop produces bubbles of flash gas which will appear in the sight glass. Remove and clean the restricted part.
 - 4. Measure the superheat of the suction gas. If necessary, readjust the superheat setting of the expansion valve.
 - 5. Observe the system operating pressures. If they appear normal, close the gauge valves.
- D. One Week Check: After the system has been in full operation for one week, provide these final checks and adjustments:
 - 1. Replace the core of the compressor filter-drier. (Or if start-up has occurred in off season, provide extra cores to Owner).
 - 2. Observe the general operation of the system: system pressures, compressor oil level, liquid line sight glass, condensing equipment, etc.
- E. Written Report: When all of the above checks have been completed, a written report from the manufacturer's authorized service representative shall be provided. This report shall list all units checked, items checked, check results, any items which may impair proper unit operation, and the name and phone number of the actual individual(s) doing the check. The report shall include a

**KOPACHUCK STATE PARK
DAY USE DEVELOPEMENT**

statement stating whether or not all units are operating as specified. Separate data/record sheets shall be provided for each of the above units.

3.5 OWNER INSTRUCTION

- A. After all testing and adjustments have been satisfactorily completed, the Owner shall be provided with operator instructions (including start-up, shut-down, emergency, maintenance, and repair instructions) by the manufacturer's authorized service representative.
- B. Time Period: Instruction period shall be for a minimum of four (4) hours.
- C. Instruction and notification shall comply with Section 230500 – General HVAC Requirements.

END OF SECTION 237300

**KOPACHUCK STATE PARK
DAY USE DEVELOPMENT**

SECTION 260500 - COMMON WORK RESULTS FOR ELECTRICAL

PART 1 - GENERAL

1.1 RELATED DOCUMENTS

- A. Drawings and general provisions of the Contract, including General Conditions and Division 1 Specification Sections, apply to this Section.

1.2 SUMMARY

- A. This section includes general electrical requirements for all Division 26 work and is supplemental and in addition to the requirements of Division 1. See Division 01 for sequence of work.
- B. It is the intention of this Division of the Specifications and the Contract Drawings to describe and provide for the furnishing, installing, testing and placing in satisfactory and fully operational condition all equipment, materials, devices and necessary appurtenances to provide a complete electrical system. Provide all materials, appliances and apparatus not specifically mentioned herein or shown on the drawings, but which are necessary to make a complete, fully operational installation of all electrical systems shown on the contract drawings or described herein. Connect equipment and devices furnished and installed under other Divisions of this specification (or the Owner) under this Division.
- C. Workmanship shall be of the best quality and competent and experienced electricians shall be employed and shall be under the supervision of a competent and experienced foreman.
- D. The drawings and specifications are complimentary and what is called for (or shown) in either is required to be provided as if called for in both. Where conflicting information occurs within the drawings and specifications or between the drawings and specifications, the more expensive alternative shall be used as a basis for bidding and construction.
- E. Branch Circuit Wiring: Where the drawings identify circuit numbers for items requiring electrical power, but do not indicate the manner of the wiring between the item and its source, the manner of the wiring shall be devised by the contractor utilizing the following provisions:
 - 1. Wire sizes:
 - a. Derate wiring for thermal restrictions imposed by the National Electrical Code.
 - b. If wire sizes are not otherwise indicated, wire sizes shall limit the voltage drop for circuits serving general purpose receptacles (180VA per strap) to less than 3%, based on the receptacle in the circuit that is farthest from the source being utilized with a load of 14 amps at 80% power factor. The following wire sizes and circuit lengths comply with this requirement:
 - 1) #12 up to 90 feet
 - 2) #10 up to 125 feet
 - 3) #8 up to 190 feet
 - c. Wire sizes for other loads shall limit the voltage drop to less than 3% based on the load indicated on the panel schedule.

**KOPACHUCK STATE PARK
DAY USE DEVELOPMENT**

2. Multiwire circuits: Multiwire circuits shall not be used unless specifically indicated or noted on the drawings. Provide a dedicated neutral conductor for each single pole circuit breaker.
3. Do not combine wiring of different source panels in the same raceway system, unless the panels are interconnected with sub feed or through feed lugs with no intervening disconnecting means.
4. Outlet and junction boxes: Arrange wiring extensions from junction boxes to outlet boxes to restrict the number of wires in an outlet box as required by NEC Article 314.
5. Single tubular raceways extending into panels or switchboards shall not contain more than 20 wires.

1.3 WORK IN OTHER DIVISIONS

- A. Refer to Division 27 for Communications. System elements of those Divisions require conformance and integration with the work of Division 26.

1.4 CODES, PERMITS, INSPECTION FEES

- A. The following codes and standards are referenced in the Division 26 specifications. Perform all work and provide materials and equipment in accordance with the latest referenced codes and standards of the following organizations:
 1. American National Standards Institute (ANSI)
 2. National Electrical Manufacturer's Association (NEMA)
 3. National Fire Protection Association (NFPA)
 4. Underwriter's Laboratories (UL)
 5. National Electrical Contractor's Association (NECA)
- B. Install the electrical systems based on the following:
 1. NFPA 70 National Electrical Code as adopted and amended by the Local Jurisdiction.
 2. IBC International Building Code as adopted and amended by the Local Judication.
- C. The referenced codes establish a minimum level of requirements. Where provision of the various codes conflict with each other, the more stringent provision shall govern. If any conflict occurs between referenced codes and this specification, the codes are to govern. Compliance with code requirements shall not be construed as relieving the Contractor from complying with any requirements of the drawings or specifications which may be in excess of requirements of the governing codes and rules and not contrary to same.
- D. Obtain and pay for all licenses, permits and inspections required by laws, ordinances and rules governing work specified herein. Arrange for inspection of work by the inspectors and give the inspectors all necessary assistance in their work of inspection.

1.5 COORDINATION

- A. Coordination during the bidding and pricing aspects of the contract includes determining where the work of other Divisions relies on the work of this Division for electricity and including the electrical system to match the requirements.

**KOPACHUCK STATE PARK
DAY USE DEVELOPMENT**

- B. Coordinate work with that of the other Contractors and/or other trades doing work on the project. Examine all drawings and specifications of other trades for construction details and coordination. Make every reasonable effort to provide timely notice of work affecting other trades to prevent conflicts or interference as to space requirements, dimensions, openings, block-outs, sleeving or other matters which will cause delays or necessitate work-around methods.
- C. Obtain submittals and shop drawings of all equipment with electrical connections furnished under other divisions of the specification and by the Owner. Provide all wiring in accordance with specific equipment requirements. Immediately advise the Architect of any changes which may affect the contract price.
- D. Special attention is called to the following items. Coordinate all conflicts prior to installation:
1. Door swings such that switches will be located on the "strike" side of the door.
 2. Location of grilles, pipes, sprinkler heads, ducts and other mechanical equipment so that all electrical outlets, lighting fixtures and other electrical outlets and equipment are clear from and in proper relation to these items.
 3. Location of cabinets, counters and doors so that electrical outlets, lighting fixtures and equipment are clear from and in proper relation to these items.
 4. Recessing and concealing electrical materials in CMU walls, concrete construction and precast construction.
 5. At each switchboard, panelboard and motor control center location the Contractor shall monitor the work of all trades to assure that the space and clearance requirements of code are met.
 6. Review specifications for other Divisions of the work to determine where other Divisions are requiring electrical connections. Verify electrical provisions shown on contract drawings by examining shop drawing submittals of other Divisions prior to submission to the owner. Do not proceed with ordering of supporting electrical equipment, such as circuit breakers, until electrical characteristics are verified. Proceed with rough-in only after verification of shop drawings.
- E. Digital format copies of bid drawings will be furnished to the successful bidder. Augment bid documents with additional information to ensure coordination between trades. Provide digital format electrical systems drawings showing all ceiling devices, fixtures, raceways and cable tray locations and routing to mechanical contractor to be used for coordination drawings provided by mechanical contractor. Include dimensions and elevations of devices, fixtures, raceway and cable tray.
- F. Furnish, install and place in satisfactory condition all raceways, boxes, conductors and connections and all other materials required for the electrical systems shown or noted in the contract documents to be complete, fully operational and fully tested upon completion of the project. Raceways, boxes and ground connections are shown diagrammatically only and indicate the general character and approximate location. The layout does not necessarily show the total number of raceways or boxes for the circuits required, nor are the locations of indicated runs intended to show the actual routing of the raceways.
1. Where routings of major raceways and telecommunication pathways are indicated on plan sheets, the routing information supplements the information on diagrams. If no routing information is shown, route the systems in a manner that will coordinate with new and existing infrastructure and the work of other trades.

**KOPACHUCK STATE PARK
DAY USE DEVELOPMENT**

- G. The horsepower of motors and apparatus wattage's shown on the drawings are estimated requirements of equipment furnished under other Divisions of this contract. Provide overload elements to suit actual equipment nameplate current. Where connections to variable speed drives furnished under other sections of this specification are shown, obtain the drive input current and verify the indicated drive circuit is compatible. Advise Architect of any equipment changes or substitutions affecting electrical systems.
 - H. Consult the architectural drawings for the exact height and location of all electrical equipment not specified herein or shown on the drawings. Make any minor changes (less than 6'-6" horizontal) in the location of the raceways, outlets, boxes, devices, wiring, etc., from those shown on the drawings without extra charge, where coordination requires or if so directed by the Architect before rough-in.
 - I. Provide inserts or sleeves for outlet boxes, conductors, cables and/or raceways as required. Coordinate the installation thereof with other trades.
 - J. The Contractor will not be paid for relocation of work, cuttings, patching and finishing required for work requiring reinstallation due to lack of coordination prior to installation.
- 1.6 WARRANTY
- A. Refer to General Conditions of the Contract.
- 1.7 CORRECTION OF WORK
- A. Within one year after the date of Substantial Completion of the work, the Contractor shall correct any work found to be not in conformance with the Contract Documents promptly after written notice from the owner to do so, unless the Owner has previously given the Contractor a written acceptance of such condition. This obligation shall survive acceptance of the work under this Contract and termination of the Contract. The Owner shall give such notice promptly after discovery of the condition.
- 1.8 SUBMITTALS AND SHOP DRAWINGS
- A. Submittals and Shop Drawings: Schedule so as not to delay construction schedule and no later than 30 days after award of contract, submit common brochure(s) with index and divider tabs by specification section, containing all required catalog cuts. Allow two weeks for review for each submittal and resubmittal. Incomplete submittals and shop drawings which do not comply with these requirements will be returned for correction, revision and resubmittal. Provide submittals for each product proposed for the project. See General Conditions for format, quantity, etc.
 - B. Submit in a three ring binder with hardboard covers. Submittals shall show:
 - 1. Indicate listing by UL or other approved testing agency.
 - 2. Highlight with yellow or blue marker adequate information to demonstrate materials being submitted fully comply with contract documents.
 - 3. Review and check all material prior to submittal and stamp "Reviewed and Approved".
 - C. Release of Drawing Data files

**KOPACHUCK STATE PARK
DAY USE DEVELOPMENT**

1. Contractor may request to utilize the project drawing data files for assistance in producing shop drawings. Request shall be made by signing owner/design team's requested documentation for release of the data files.

D. The Contractor agrees:

1. Submittals and shop drawings processed by the Architect are not change orders.
2. The purpose of submittals and shop drawings by the Contractor is to demonstrate to the Engineer that the Contractor understands the design concept.
3. Submittals demonstrate equipment and material Contractor intends to furnish and install and indicate detailing fabrication and installation methods Contractor intends to use.
4. To accept all responsibility for assuring that all materials furnished under this Division of the specifications meet, in full, all requirements of the contract documents.
5. To pay for Engineers review cost of submittal review beyond one resubmittal.

- E. The Engineer's review is only for general conformance with the design concept of the project and general compliance with the information given in the contract documents. Corrections or comments made during this review do not relieve contractor from compliance with the requirements of the drawings and specifications. Contractor is responsible for: Dimensions which shall be confirmed and correlated at the job site; fabrication process and techniques of construction; coordination of his work with that of all other trades; performing his work in a safe and satisfactory manner.

1.9 PROJECT CLOSE-OUT

- A. Coordinate with close-out provisions in Division 01 - General Requirements.

B. Request For Final Punchlist

1. To request a final electrical punch list, forward a letter to the Architect. stating; "The electrical work on this project is complete, all punch list items to date are complete, items a. - l. in the Project Punchlist Procedure paragraph 1.9B2 in Section 260500 - Common Work Results For Electrical are complete and the project is ready for final punch list observation."
2. Project Punchlist Procedure: Perform the following procedures for project closeout of electrical portions of work.
 - a. Perform testing, tests and documentation per Section 260126 - Maintenance Testing of Electrical Systems.
 - b. Provide engraved nameplates on electrical equipment.
 - c. Refinish electrical equipment finishes which are damaged.
 - d. Clean light fixtures per Section 260500 - Common Work Results For Electrical.
 - e. Color code junction boxes per Section 260533 - Raceways and Boxes For Electrical Systems.
 - f. Insert word processed (typed) Panel Schedules in all new and existing panelboards with actual "as-built" circuit descriptions.
 - g. Number all circuit breakers.
 - h. Obtain final electrical permit inspection. Include copies in O & M manual.
 - i. Provide written warranty in O & M per the General Conditions of the Contract.
 - j. Furnish As-built Drawings per this section.
 - k. Furnish O & M Manuals per this section.
 - l. Give instruction periods to owner's personnel per this section.

**KOPACHUCK STATE PARK
DAY USE DEVELOPMENT**

- 1.10 ELECTRICAL EQUIPMENT OPERATION AND MAINTENANCE (O&M) MANUALS
- A. Provide O&M manuals required in Division 01 - General Requirements for all equipment furnished under Division 26 - Electrical of the specifications. Submit a preliminary copy, complete except for the bound cover, 60 days prior to completion of the project for checking and review. Deliver final bound corrected copies as noted in Division 1 - General Requirements 20 days prior to scheduled instruction periods. Obtain a receipt for the manuals and forward a copy of the receipt to the Engineer with the Job Completion Form.
 - B. The information included must be the exact equipment installed. Where sheets show the equipment installed and other equipment, the installed equipment shall be neatly and clearly identified on such sheets.
 - C. These O&M manuals shall contain all the information needed to operate and maintain all systems and equipment provided in the project. Present and arrange information in a logical manner for efficient use by the Owner's operating personnel. The information provided shall include but not be limited to the following:
 - 1. Equipment manufacturer, make, model number, size, nameplate data, etc.
 - 2. Description of system configuration and operation including component identification and interrelations. A master control schematic drawing(s) may be required for this purpose.
 - 3. Dimensional and performance data for specific unit provided as appropriate.
 - 4. Manufacturer's recommended operation instructions.
 - 5. Manufacturer's recommended lubrication and servicing data including frequency.
 - 6. Complete parts list including reordering information, recommended spares and anticipated useful life (if appropriate). Parts lists shall give full ordering information assigned by the original parts manufacturer. Relabeled and/or renumbered parts information as reassigned by equipment supplier not acceptable. Include the parts list and part diagram that was included with the product's packaging, note that a "catalog cut" will not meet this criterion.
 - 7. Shop drawings.
 - 8. Wiring diagrams.
 - 9. Signal equipment submittals shall contain step-by-step circuit description information designed to acquaint maintenance personnel with equipment operation in each mode of operation.
 - 10. A complete list of local (nearest) manufacturer representative and distributor contacts for each type of equipment and manufacturer. Include name, company, address, phone, fax, e-mail address, and web site.
 - D. Furnish complete wiring diagrams for each system for the specific system installed under the contract. "Typical" line diagrams will not be acceptable unless revised to indicate the exact field installation.
 - E. Group the information contained in the manuals in an orderly arrangement by specification index. Provide a typewritten index and divider sheets between categories with identifying tabs. Bind the completed manuals with hard board covers not exceeding 5" thick. (Provide two or more volumes if required.) Signal and communication systems shall be in separate volumes. Imprint the covers with the name of the job, Owner, Architect, Electrical Engineer, Contractor and year of completion. Imprint the back edge with the name of the job, Owner and year of

**KOPACHUCK STATE PARK
DAY USE DEVELOPMENT**

completion. Hard board covers and literature contained may be held together with screw post binding.

1.11 INSTRUCTION PERIODS

- A. After substantial completion of the work and 20 days after the O&M manuals have been delivered to the owner and after all tests and final inspection of the work by the Authority(s) Having Jurisdiction; demonstrate the electrical systems and instruct the Owner's designated operating and maintenance personnel in the operation and maintenance of the various electrical systems. The Contractor shall arrange scheduled instruction periods with the Owner. The Contractor's representatives shall be superintendents or foremen knowledgeable in each system and suppliers' representatives when so specified. When more than one training session is specified, the second session shall be 30 to 90 days after the first as agreed to by the Owner.
- B. Include in each instruction session an overview of the system, presentation of information in maintenance manuals with appropriate references to drawings. Conduct tours of the building areas with explanations of maintenance requirements, access methods, servicing and maintenance procedures, equipment cleaning procedures and adjustment locations.
- C. Include the following scheduled instruction periods:

	1 st Session	2 nd Session
1. Lighting Control & Dimming System	[2] hours	[2] hours

1.12 AS-BUILT DRAWINGS

- A. As-built drawings shall be kept on: the contract drawings, shop drawings indicating field wiring, vendor diagrams indicating field wiring, and similar documents.
- B. Continually record the actual electrical system(s) installation on a set of prints kept readily available at the project during construction. These prints shall be used for this purpose alone.
 - 1. Mark record prints with red erasable pencil. Mark the set to show the actual installation where the installation varies substantially from the work as originally shown.
 - 2. Accurately locate with exact dimensions all underground and underslab raceways and stub-outs.
 - 3. Note changes of directions and locations, by dimensions and elevations, as utilities are actually installed.
 - 4. Include addenda items and revisions made during construction.
 - 5. Erase conditions not constructed or "X-out" and annotate "not constructed" to clearly convey the actual "as constructed" condition.
 - 6. Organize as-built drawings sheets in manageable sets, bind and print suitable titles, dates and other identification on the cover of each set.
 - 7. Where "typical" wiring diagrams were used during submittals the as-built drawings shall indicate exact point to point wiring with exact terminal number designations.
- C. Transmit the as-built drawing set to the Architect at the completion of the work. Final payment to the contractor will not be authorized until these prints have been submitted to and accepted by the Architect.
- D. Transfer the changes marked up on the record prints into AutoCAD drawing files at the completion of the work. The version of AutoCAD shall not be earlier than the most recent

**KOPACHUCK STATE PARK
DAY USE DEVELOPMENT**

version available at the date the project bids were received. AutoCAD files shall not include the stamp of the engineer of record. Provide two (2) sets of prints, one set of fixed line reproducible drawings and one set of AutoCAD drawing files on US Flash Drive. Transmit drawings, AutoCAD drawing files and the as-built drawing mark-ups to the Architect. Final payment to the contractor will not be authorized until these documents have been submitted to and accepted by the Architect.

1.13 ABBREVIATIONS AND DEFINITIONS

- A. When the following abbreviations and definitions are used in relation to the work for Division 26 they shall have the following meanings:

<u>Item</u>	<u>Meaning</u>
AHJ	Authority Having Jurisdiction.
Boxes	Outlet, Junction or Pull Boxes.
Code	All applicable codes currently enforced at project location.
Compression	Compressed using a leveraged powered (hydraulic or equivalent) crimping tool.
Connection	All materials and labor required for equipment to be fully operational.
Exterior Location	Outside of or penetrating the outer surfaces of the building weather protective membrane.
Fully Operational	Tested, approved, and operating to the satisfaction of the AHJ, manufacturer and contract documents.
Furnish	Deliver to the jobsite
Install	To enter permanently into the project and make fully operational.
Kcml	Thousand circular mils (formerly MCM).
Mfr.	Manufacturer.
NEC	National Electrical Code, National Fire Protection Association, Publication #70.
NIC	Not in Contract.
Noted	Shown or specified in the contract documents.
Provide	Furnish and install.
Required	As required by code, AHJ, contract documents, or manufacturer for the particular installation to be fully operational.
Shown	As indicated on the drawings or details.
Wiring	Raceway, conductors and connections.

PART 2 - PRODUCTS

2.1 GENERAL

- A. All materials and equipment installed shall have been tested and listed by Underwriters Laboratories or other approved testing organization and shall be so labeled unless otherwise permitted by the Authority Having Jurisdiction (Inspector).
- B. All materials to be new, free from defects and not less than quality herein specified. Materials shall be designated to insure satisfactory operation and operational life in the environmental conditions which will prevail where they are being installed.

**KOPACHUCK STATE PARK
DAY USE DEVELOPMENT**

- C. Each type of materials furnished shall be of the same make, be standard products of manufacturers regularly engaged in production of such materials and be the manufacturer's latest standard design.
- D. All materials, equipment and systems furnished that include provisions for storing, displaying, reporting, interfacing, inputting, or functioning using date specific information shall perform properly in all respects regardless of the century. Any interface to other new or existing materials, equipment or systems shall function properly and shall be century compliant, both in regard to information sent and received.

2.2 SUBSTITUTION OF MATERIALS

- A. No Substitute:
 - 1. Where a specified product is indicated "no substitute", it is the intent of this specification to require new materials to be compatible with the existing installation or as specifically requested by the owner. To this end certain materials and systems no substitution will be allowed.
- B. After Award of Contract:
 - 1. Substitution of products will be considered after award of contract only under the following conditions:
 - a) The Contractor shall have placed orders for specified materials promptly after contract is awarded and the specified products cannot be delivered to the project to meet the Owner's construction schedule.
 - b) The reason for the unavailability is beyond the Contractor's control, i.e., due to strikes, bankruptcy, discontinuance of manufacturer, acts of God.
 - c) The specified product is no longer manufactured.
 - d) There is compelling economic advantage to the Owner.
- C. In all cases, should a substituted material result in requiring electrical system or building modifications; the Contractor alone shall pay all costs to provide these modifications including all costs to the Engineer and Architect for redesign, and updating of record drawings required to accommodate the required modifications.

2.3 NAMEPLATES

- A. Provide nameplates per Section 260553 - Identification for Electrical Systems.

PART 3 - EXECUTION

3.1 GENERAL

- A. All work shall be done in accordance with NECA construction standards.
- B. Adhere to industry standards of care for safety, including:
 - 1. Occupational Safety and Health Act.
 - 2. Accident Prevention Manual for Industrial Operations, National Safety Council.

**KOPACHUCK STATE PARK
DAY USE DEVELOPMENT**

3. ANSI/NFPA 70E, Electrical Safety Requirements for Employee Workplaces.
4. American National Standards for Personnel Protection: Lockout/Tagout.
5. Applicable state and local safety operating procedures.

3.2 PRODUCT DELIVERY, STORAGE AND HANDLING

- A. Deliver, store, and handle products according to the manufacturer's recommendations, using means and methods that will prevent damage, deterioration, and loss, including theft. Handle all equipment carefully to prevent damage, breakage, denting, and scoring of finishes. Do not install damaged equipment.
- B. Store products subject to damage by the elements above ground, undercover in a weather tight enclosure, with ventilation adequate to prevent condensation. Maintain temperature and humidity within range required by manufacturer's instruction.

3.3 CUTTING BUILDING CONSTRUCTION

- A. Obtain permission from the Architect and coordinate with other trades prior to cutting. Locate cuttings so they will not weaken structural components. Cut carefully and only the minimum amount necessary. Cut concrete with diamond core drills or concrete saws except where space limitations prevent the use of such tools.
- B. All construction materials damaged or cut into during the installation of this work must be repaired or replaced with materials of like kind and quality as original materials by skilled labor experienced in that particular building trade.

3.4 PENETRATION OF BUILDING ELEMENTS

- A. General:
 1. Penetrations of building elements by electrical systems shall not compromise the performance and integrity of the building element (structural, fire, smoke, waterproof, etc.)
- B. Fire and smoke rated elements:
 1. Electrical penetrations of fire and smoke rated floor and wall assemblies shall maintain fire-resistance or smoke barrier rating of the assembly.

3.5 PAINTING

- A. Items furnished under this Division that are scratched or marred in shipment or installation shall be refinished with touchup paint selected to match installed equipment finish.

3.6 EQUIPMENT CONNECTION

- A. For equipment furnished under this or other Divisions of the specifications, or by owner, provide all electrical connections necessary to serve such equipment and provide required control connections to all equipment so that the equipment is fully operational upon completion of the project. Investigate existing equipment to be relocated and provide new connections as required.

**KOPACHUCK STATE PARK
DAY USE DEVELOPMENT**

- B. Contract Coordination: Investigate vendor equipment proposed for installation and address and integrate the following into the construction process:
 - 1. Special equipment requirements identified in shop drawings or submittals.
 - 2. Equipment requirements for distribution system performance, for example, an external disconnect switch or fused disconnect switch to provide compliance with a governing code, a short circuit current rating, or a listing.
- C. Obtain rough-in requirements for equipment furnished under other divisions of this specification prior to roughing-in.

3.7 HOUSEKEEPING PADS

- A. Provide steel reinforced concrete housekeeping pad under each floor mounted switchboard, transformer, motor control center, generator and/or other free standing electrical equipment. Size 4" greater (horizontal minimum) than base of equipment mounted thereon. Minimum height 3-1/2". Use 3000-psi (20.7-Mpa), 28 day compressive strength concrete and reinforcement as specified in Division 3 Section "Cast-in-Place Concrete". Chamfer edges and finish smooth with all blockouts square and plumb.
- B. When housekeeping pad is poured on previously poured concrete or is for engine or motor driven equipment, the pad shall be reinforced (4# rebar, 12" o.c., both ways) and the rebar shall be tied to the existing floor via #4 rebar epoxy grouted into the existing concrete on 18" centers or other acceptable means. The existing slab shall be thoroughly cleaned and prepared for the pad just before the pour.

3.8 CLEAN UP

- A. Contractor shall continually remove debris, cuttings, crates, cartons, etc., created by his work. Such clean up shall be done daily and at sufficient frequency to eliminate hazard to the public, other workmen, the building or the Owner's employees. Before acceptance of the installation, Contractor shall carefully clean cabinets, panels, lighting fixtures, wiring devices, cover plates, etc., to remove dirt, cuttings, paint, plaster, mortar, concrete, etc. Blemishes to finished surfaces of apparatus shall be removed and new finish equal to the original applied.
 - 1. Wipe surfaces of electrical equipment. Remove excess lubrication, paint and mortar droppings, and other foreign substances.
 - 2. Clean light fixtures, lamps, globes, and reflectors to function with full efficiency. Replace burned-out bulbs, and those noticeably dimmed by hours of use, and defective and noisy starters in fluorescent, high pressure sodium, metal halide, and mercury vapor fixtures to comply with requirements for new fixtures.

3.9 TESTING AND DEMONSTRATION

- A. Demonstrate that all electrical equipment operates as specified and in accordance with manufacturer's instructions. Perform tests in the presence of the Architect, Owner or Engineer. Provide all instruments, manufacturer's operating instructions and personnel required to conduct the tests. Repair or replace any electrical equipment that fails to operate as specified and or in accordance with manufacturer's requirements.

**KOPACHUCK STATE PARK
DAY USE DEVELOPMENT**

- B. Contractor shall remove and replace covers of electrical equipment, open manholes and remove/replace ceiling tiles to permit engineer to observe equipment and wiring provided. For manholes: Furnish OSHA safety compliant equipment and personnel, including ventilation, safety harness, ladder and flashlight.

END OF SECTION 260500

**KOPACHUCK STATE PARK
DAY USE DEVELOPMENT**

SECTION 260519 - LOW-VOLTAGE ELECTRICAL POWER CONDUCTORS AND CABLES

PART 1 - GENERAL

1.1 RELATED DOCUMENTS

- A. Drawings and general provisions of the Contract, including General Conditions and Division 01 Specification Sections, apply to this Section.

1.2 SUBMITTALS

- A. Product Data: For each type of product.
- B. Field quality-control reports.

PART 2 - PRODUCTS

2.1 CONDUCTORS AND CABLES

- A. Manufacturers: Subject to compliance with requirements, available manufacturers offering products that may be incorporated into the Work include, but are not limited to, the following:
 - 1. Alcan Products Corporation; Alcan Cable Division.
 - 2. Alpha Wire.
 - 3. Belden Inc.
 - 4. Encore Wire Corporation.
 - 5. General Cable Technologies Corporation.
 - 6. Southwire Incorporated.
- B. Copper Conductors: Comply with NEMA WC 70/ICEA S-95-658.
- C. Conductor Insulation: Comply with NEMA WC 70/ICEA S-95-658 form Type THHN-THWN.
- D. Multi-conductor Cable: Comply with NEMA WC 70/ICEA S-95-658 for metal-clad cable, Type MC with ground wire.

2.2 CONNECTORS AND SPLICES

- A. Manufacturers: Subject to compliance with requirements, available manufacturers offering products that may be incorporated into the Work include, but are not limited to, the following:
 - 1. AFC Cable Systems, Inc.
 - 2. Gardner Bender.
 - 3. Hubbell Power Systems, Inc.
 - 4. Ideal Industries, Inc.
 - 5. IlSCO; a branch of Bardes Corporation.

**KOPACHUCK STATE PARK
DAY USE DEVELOPMENT**

6. NSi Industries LLC.
 7. O-Z/Gedney; a brand of the EGS Electrical Group.
 8. 3M; Electrical Markets Division.
 9. Tyco Electronics.
- B. Description: UL listed, factory-fabricated connectors and splices of size, ampacity rating, material, type, and class for application and service indicated.
- C. For #14 through #10 AWG wire sizes, provide insulated spring wire connectors or insulated compression connectors.
- D. For #8 AWG wire, use solderless pressure connectors with insulating sleeves.
- E. For #6 AWG and through #2, optional use split bolt connectors with manufactured insulation covers or tape sufficient to provide 150% insulation level.
- F. For #6 and larger: Compression connectors using compression dies designed for the exact connector being terminated. Provide insulating sleeves manufactured specifically for the connector being used. Mechanical termination integral to overcurrent protective devices are also acceptable.

2.3 SYSTEM DESCRIPTION

- A. Electrical Components, Devices, and Accessories: Listed and labeled as defined in NFPA 70, by a qualified testing agency, and marked for intended location and application.
- B. Comply with NFPA 70.

PART 3 - EXECUTION

3.1 CONDUCTOR MATERIAL APPLICATIONS

- A. Feeders: Copper. Solid for No. 10 AWG and smaller; stranded for No. 8 AWG and larger.
- B. Branch Circuits: Copper. Solid for No. 10 AWG and smaller; stranded for No. 8 AWG and larger, except VFC cable, which shall be extra flexible stranded.

3.2 CONDUCTOR INSULATION AND MULTICONDUCTOR CABLE APPLICATIONS AND WIRING METHODS

- A. Service Entrance: Type THHN-THWN, single conductors in raceway.
- B. Exposed Feeders and Branch Circuits: Type THHN-THWN, single conductors in raceway.
- C. Feeders and Branch Circuits Concealed in Ceilings, Walls, Partitions, and Crawlspace: Type THHN-THWN, single conductors in raceway.

**KOPACHUCK STATE PARK
DAY USE DEVELOPMENT**

- D. Feeders and Branch Circuits Concealed in below grade concrete walls, below Slabs-on-Grade, and Underground: Type XHHW-2, single conductors in raceway.
- E. Feeder and Branch Circuits exposed above roofing: XHHW-2.
- F. Cord Drops and Portable Appliance Connections: Type SO, hard service cord with stainless-steel, wire-mesh, strain relief device at terminations to suit application.

3.3 INSTALLATION OF CONDUCTORS AND CABLES

- A. Conceal cables in finished walls, ceilings, and floors unless otherwise indicated.
- B. Complete raceway installation between conductor and cable termination points according to Section 260533 - Raceways and Boxes for Electrical Systems - prior to pulling conductors and cables.
- C. Use manufacturer-approved pulling compound or lubricant where necessary; compound used must not deteriorate conductor or insulation. Do not exceed manufacturer's recommended maximum pulling tensions and sidewall pressure values.
- D. Use pulling means, including fish tape, cable, rope, and basket-weave wire/cable grips, that will not damage cables or raceway.
- E. Install exposed cables parallel and perpendicular to surfaces of exposed structural members and follow surface contours where possible.

3.4 CONNECTIONS

- A. Tighten electrical connectors and terminals according to manufacturer's published torque-tightening values. If manufacturer's torque values are not indicated, use those specified in UL 486A-486B.
- B. Make splices, terminations, and taps that are compatible with conductor material and that possess equivalent or better mechanical strength and insulation ratings than unspliced conductors.
 - 1. Use oxide inhibitor in each splice, termination, and tap for aluminum conductors.
- C. Wiring at Outlets: Install conductor at each outlet, with at least 6 inches of slack.

3.5 IDENTIFICATION

- A. Identify and color-code conductors and cables according to Section 260553 - Identification for Electrical Systems.
- B. Identify each spare conductor at each end with identity number and location of other end of conductor and identify as spare conductor.

**KOPACHUCK STATE PARK
DAY USE DEVELOPMENT**

3.6 PENETRATIONS

- A. Penetrate fire barriers, smoke barriers, vapor barriers, roofing materials and other rated architectural elements in a manner that preserves the rating of the architectural element.

3.7 FIELD QUALITY CONTROL

- A. Testing Agency: Engage a qualified testing agency to perform tests and inspections.
- B. Manufacturer's Field Service: Engage a factory-authorized service representative to test and inspect components, assemblies, and equipment installations, including connections.
- C. Perform the following tests and inspections:
 - 1. Perform each visual and mechanical inspection and electrical test stated in NETA Acceptance Testing Specification. Certify compliance with test parameters.
- D. Test and Inspection Reports: Prepare a written report to record the following:
 - 1. Procedures used.
 - 2. Results that comply with requirements.
 - 3. Results that do not comply with requirements and corrective action taken to achieve compliance with requirements.
- E. Cables will be considered defective if they do not pass tests and inspections.

END OF SECTION 260519

**KOPACHUCK STATE PARK
DAY USE DEVELOPMENT**

SECTION 260526 - GROUNDING AND BONDING FOR ELECTRICAL SYSTEMS

PART 1 - GENERAL

1.1 RELATED DOCUMENTS

- A. Drawings and general provisions of the Contract, including General and Supplementary Conditions and Division 01 Specification Sections, apply to this Section.

1.2 SUBMITTALS

- A. Product Data: For each type of product indicated.
- B. Plans showing dimensioned as-built locations of grounding features specified in "Field Quality Control" Article, including the following:
 - 1. Test wells.
 - 2. Ground rods.
 - 3. Ground rings.
 - 4. Grounding arrangements and connections for separately derived systems.
 - 5. Grounding for sensitive electronic equipment.
- C. Field quality-control reports.
- D. Operation and Maintenance Data: For grounding to include in emergency, operation, and maintenance manuals.

PART 2 - PRODUCTS

2.1 GENERAL

- A. Electrical Components, Devices, and Accessories: Listed and labeled as defined in NFPA 70, by a qualified testing agency, and marked for intended location and application.
- B. Comply with UL 467 for grounding and bonding materials and equipment.

2.2 CONDUCTORS

- A. Insulated Conductors: Copper wire or cable insulated for 600 V unless otherwise required by applicable Code or authorities having jurisdiction.
- B. Bare Copper Conductors:

KOPACHUCK STATE PARK DAY USE DEVELOPMENT

1. Solid Conductors: ASTM B 3.
2. Stranded Conductors: ASTM B 8.
3. Tinned Conductors: ASTM B 33.

- C. Grounding Bus: Predrilled rectangular bars of annealed copper, 1/4 by 4 inches in cross section, with 9/32-inch holes spaced 1-1/8 inches apart. Stand-off insulators for mounting shall comply with UL 891 for use in switchboards, 600 V. Lexan or PVC, impulse tested at 5000 V.

2.3 CONNECTORS

- A. Listed and labeled by an NRTL acceptable to authorities having jurisdiction for applications in which used and for specific types, sizes, and combinations of conductors and other items connected.
- B. Bolted Connectors for Conductors and Pipes: Copper or copper alloy, pressure type with at least two bolts.
1. Pipe Connectors: Clamp type, sized for pipe.
- C. Welded Connectors: Exothermic-welding kits of types recommended by kit manufacturer for materials being joined and installation conditions.
- D. Bus-bar Connectors: Mechanical type, cast silicon bronze, solder less compression-type wire terminals, and long-barrel, two-bolt connection to ground bus bar.

2.4 GROUNDING ELECTRODES

- A. Ground Rods: Copper-clad steel; 3/4-inch diameter by 10 feet.
- B. Ufer Ground (Concrete-Encased Grounding Electrode): Fabricate according to NFPA 70; use a minimum of 20 feet (6 m) of bare copper conductor not smaller than No. 4 AWG

PART 3 - EXECUTION

3.1 APPLICATIONS

- A. Provide grounding and bonding required by NFPA 70, as adopted by the local authority having jurisdiction. Detailed aspects of code requirements for grounding and bonding may not be indicated within the contract documents, however, all aspects of code compliance are the responsibility of the contractor.
- B. Conductors: Install solid conductor for No.10 AWG and smaller, and stranded conductors for larger unless otherwise indicated.
- C. Underground Grounding Conductors: Install bare copper conductor, No.2 AWG minimum.

KOPACHUCK STATE PARK DAY USE DEVELOPMENT

1. Bury at least 24 inches below grade.
- D. Isolated Grounding Conductors: Green-colored insulation with continuous yellow stripe. On feeders with isolated ground, identify grounding conductor where visible to normal inspection, with alternating bands of green and yellow tape, with at least three bands of green and two bands of yellow.
- E. Grounding Bus: Install in electrical and telephone equipment rooms, in rooms housing service equipment, and elsewhere as indicated.
1. Install bus on insulated spacers 2 inches minimum from wall, 6 inches above finished floor unless otherwise indicated.
 2. Where indicated on both sides of doorways, route bus up to top of door frame, across top of doorway, and down to specified height above floor; connect to horizontal bus.
- F. Conductor Terminations and Connections:
1. Pipe and Equipment Grounding Conductor Terminations: Bolted connectors.
 2. Underground Connections: Welded connectors except at test wells and as otherwise indicated.
 3. Connections to Ground Rods at Test Wells: Bolted connectors.
 4. Connections to Structural Steel: Welded connectors.

3.2 UNDERGROUND DISTRIBUTION SYSTEM

- A. Comply with IEEE C2 grounding requirements.
- B. Grounding Manholes and Handholes: Install a driven ground rod through manhole or handhole floor, close to wall, and set rod depth so 4 inches (100 mm) will extend above finished floor. If necessary, install ground rod before manhole is placed and provide No. 1/0 AWG bare, tinned-copper conductor from ground rod into manhole through a waterproof sleeve in manhole wall. Protect ground rods passing through concrete floor with a double wrapping of pressure-sensitive insulating tape or heat-shrunk insulating sleeve from 2 inches (50 mm) above to 6 inches (150 mm) below concrete. Seal floor opening with waterproof, nonshrink grout. Bond ground rod to duct bank grounding conductors.
- C. Grounding Connections to Metal Parts: Bond exposed-metal parts such as lid, inserts, cable racks, pulling irons, ladders, and cable shields within each manhole or handhole, to ground rod or grounding conductor. Make connections with No. 4 AWG minimum, stranded, hard-drawn copper bonding conductor. Train conductors level or plumb around corners and fasten to manhole walls. Connect to cable armor and cable shields according to written instructions by manufacturer of splicing and termination kits.
- D. Pad-Mounted Transformers and Switches: Install two ground rods and ground ring around the pad. Ground pad-mounted equipment and noncurrent-carrying metal items associated with substations by connecting them to underground cable and grounding electrodes. Install tinned-copper conductor not less than No. 2 AWG for ground ring and for taps to equipment grounding terminals. Bury ground ring not less than 6 inches (150 mm) from the foundation.

**KOPACHUCK STATE PARK
DAY USE DEVELOPMENT**

3.3 EQUIPMENT GROUNDING

- A. Install insulated equipment grounding conductors with all feeders and branch circuits.
- B. Isolated Grounding Receptacle Circuits: Install an insulated equipment grounding conductor connected to the receptacle grounding terminal. Isolate conductor from raceway and from panelboard grounding terminals. Terminate at equipment grounding conductor terminal of the applicable derived system or service unless otherwise indicated.
- C. Isolated Equipment Enclosure Circuits: For designated equipment supplied by a branch circuit or feeder, isolate equipment enclosure from supply circuit raceway with a nonmetallic raceway fitting listed for the purpose. Install fitting where raceway enters enclosure and install a separate insulated equipment grounding conductor. Isolate conductor from raceway and from panelboard grounding terminals. Terminate at equipment grounding conductor terminal of the applicable derived system or service unless otherwise indicated.
- D. Signal and Communication Equipment: In addition to grounding and bonding required by NFPA 70, provide a separate grounding system complying with requirements in TIA/ATIS J-STD-607-A.
 - 1. For telephone, alarm, voice and data, and other communication equipment, provide No. 4 AWG minimum insulated grounding conductor in raceway from grounding electrode system to each service location, terminal cabinet, wiring closet, and central equipment location.
 - 2. Service and Central Equipment Locations and Wiring Closets: Terminate grounding conductor on a 1/4-by-4-by-12-inch (6.3-by-100-by-300-mm) grounding bus.
 - 3. Terminal Cabinets: Terminate grounding conductor on cabinet grounding terminal.
- E. Poles Supporting Outdoor Lighting Fixtures: Install grounding electrode in addition to grounding conductor installed with branch-circuit conductors.

3.4 INSTALLATION

- A. Grounding Conductors: Route along shortest and straightest paths possible unless otherwise indicated or required by Code. Avoid obstructing access or placing conductors where they may be subjected to strain, impact, or damage.
- B. Ground Bonding Common with Lightning Protection System: Comply with NFPA 780 and UL 96 when interconnecting with lightning protection system. Bond electrical power system ground directly to lightning protection system grounding conductor at closest point to electrical service grounding electrode. Use bonding conductor sized same as system grounding electrode conductor and install in conduit.
- C. Ground Rods: Drive rods until tops are 2 inches (50 mm) below finished floor or final grade unless otherwise indicated.
 - 1. Interconnect ground rods with grounding electrode conductor below grade and as otherwise indicated. Make connections without exposing steel or damaging coating if any.

**KOPACHUCK STATE PARK
DAY USE DEVELOPMENT**

2. Retain subparagraph below if grounding installation requirements are not detailed on Drawings. Subparagraph exceeds NFPA 70 requirements.
 3. For grounding electrode system, install at least three rods spaced at least one-rod length from each other and located at least the same distance from other grounding electrodes, and connect to the service grounding electrode conductor.
- D. Test Wells: Ground rod driven through drilled hole in bottom of handhole. Handholes are specified in Section 250533 – Raceways and Boxes for Electrical Systems, and shall be at least 12 inches (300 mm) deep, with cover.
1. Test Wells: Install at least one test well for each service unless otherwise indicated. Install at the ground rod electrically closest to service entrance. Set top of test well flush with finished grade or floor.
- E. Bonding Straps and Jumpers: Install in locations accessible for inspection and maintenance except where routed through short lengths of conduit.
1. Bonding to Structure: Bond straps directly to basic structure, taking care not to penetrate any adjacent parts.
 2. Bonding to Equipment Mounted on Vibration Isolation Hangers and Supports: Install bonding so vibration is not transmitted to rigidly mounted equipment.
 3. Use exothermic-welded connectors for outdoor locations; if a disconnect-type connection is required, use a bolted clamp.
- F. Grounding and Bonding for Piping:
1. Metal Water Service Pipe: Install insulated copper grounding conductors, in conduit, from building's main service equipment, or grounding bus, to main metal water service entrances to building. Connect grounding conductors to main metal water service pipes; use a bolted clamp connector or bolt a lug-type connector to a pipe flange by using one of the lug bolts of the flange. Where a dielectric main water fitting is installed, connect grounding conductor on street side of fitting. Bond metal grounding conductor conduit or sleeve to conductor at each end.
 2. Water Meter Piping: Use braided-type bonding jumpers to electrically bypass water meters. Connect to pipe with a bolted connector.
 3. Bond each aboveground portion of gas piping system downstream from equipment shutoff valve.
- G. Grounding for Steel Building Structure: Install a driven ground rod at base of each corner column and at intermediate exterior columns at distances not more than 60 feet (18 m) apart. Bond rods together.
- H. Ground Ring: Install a grounding conductor, electrically connected to each building structure ground rod and to each steel column, extending around the perimeter of building.
1. Install bare copper conductor not less than No. 3/0 AWG for ground ring and for taps to building steel.
 2. Bury ground ring not less than 24 inches (600 mm) from building's foundation.
- I. Ufer Ground:

**KOPACHUCK STATE PARK
DAY USE DEVELOPMENT**

1. Provide Ufer grounding electrode.
2. Bond grounding conductor to reinforcing steel in at least four locations and to anchor bolts. Extend grounding conductor below grade and connect to building's grounding grid or to grounding electrode external to concrete.

3.5 LABELING

- A. Comply with requirements in Section "260553 - Identification for Electrical Systems" for instruction signs. The label or its text shall be green.
- B. Install labels at the telecommunications bonding conductor and grounding equalizer and at the grounding electrode conductor where exposed.
 1. Label Text: "If this connector or cable is loose or if it must be removed for any reason, notify the facility manager."

3.6 TESTING

- A. Tests and Inspections:
 1. After installing grounding system but before permanent electrical circuits have been energized, test for compliance with requirements.
 2. Inspect physical and mechanical condition. Verify tightness of accessible, bolted, electrical connections with a calibrated torque wrench according to manufacturer's written instructions.
 3. Grounding Electrodes;
 - a. Test completed grounding system at service disconnect and at ground test wells. Perform tests by fall-of-potential method according to IEEE 81.
 - b. Provide a supplemental grounding electrode where system ground resistance exceeds 10 ohms and retest. If resistance to ground still exceeds specified values, notify Architect promptly and include recommendations to reduce ground resistance.
- B. Grounding system will be considered defective if it does not pass tests and inspections.
- C. Prepare test and inspection reports.

3.7 GROUNDING ELECTRODES

- A. Provide as shown and/or required. Connect the grounding electrode conductor to each grounding electrode.

3.8 SIZE OF GROUND WIRE

- A. As required by National Electric Code. Where ground wire is exposed to physical damage protect with rigid non-ferrous conduit as permitted by applicable code.

**KOPACHUCK STATE PARK
DAY USE DEVELOPMENT**

3.9 GROUND CONNECTION OF PIPING

- A. Metal internal piping shall be grounded.

3.10 CONNECTION TO THE POWER GROUND BUS

- A. Furnish and install connections in accordance with the codes; including but not limited to:
 - 1. Raceway system
 - 2. Switchboard
 - 3. Service neutral
 - 4. "Separately derived system" (transformer or emergency power supply)
 - 5. Electrically operated equipment and devices.

- B. No device or equipment shall be connected for electrical service which has a neutral conductor connected to a grounding conductor or to the frame within the device or equipment.

3.11 METHOD OF CONNECTIONS

- A. Make all ground connections and ground cable splices by thermal welding or copper compression set type connectors U.L. listed for grounding purposes. Grounding lugs, where provided as standard manufacturer's items on equipment furnished, may be used.

3.12 EXPANSION FITTINGS

- A. In conduit runs requiring an expansion fitting, a bonding jumper shall be installed around the fitting to maintain continuous ground continuity. Jumper shall allow for maximum movement of the fitting.

3.13 GROUND CABLE CROSSING EXPANSION JOINTS

- A. Ground cables crossing expansion joints or similar separations in structures or paved areas shall be protected from damage by means of suitable approved devices or methods of installation which will provide the necessary slack in the cable across the joint to permit movement. Stranded or other approved flexible copper run or jumper shall be used across such separations.

3.14 GROUNDING FOR FEEDERS

- A. Provide a grounding bushing with ground conductor sized in accordance with NEC table 250.122 to the grounding bus in the panelboard and switchboards.

3.15 PANELBOARD BONDING

- A. Provide a bonding conductor not smaller than #10 AWG between the ground bus in the normal and emergency panels and/ or two or more emergency panelboards fed from separate transfer switches, serving the same individual patient vicinity in accordance with NEC 517.14.

**KOPACHUCK STATE PARK
DAY USE DEVELOPMENT**

END OF SECTION 260526

**KOPACHUCK STATE PARK
DAY USE DEVELOPMENT**

SECTION 260533 - RACEWAYS AND BOXES FOR ELECTRICAL SYSTEMS

PART 1 - GENERAL

1.1 RELATED DOCUMENTS

- A. Drawings and general provisions of the Contract, including General Conditions and Division 01 Specification Sections, apply to this Section.

1.2 DEFINITIONS

- A. AASHTO American Association of State Highway and Transportation Officials
- B. ARC: Aluminum rigid conduit.
- C. EMT: Electrical metallic tubing.
- D. EPDM: Ethylene-propylene-diene terpolymer rubber.
- E. FMC: Flexible metal conduit
- F. GRC: Galvanized rigid steel conduit.
- G. IMC: Intermediate metal conduit.
- H. LFMC: Liquid tight flexible metal conduit.
- I. LFNC: Liquidtight flexible nonmetallic conduit.
- J. NBR: Acrylonitrile-butadiene rubber.
- K. RNC: Rigid nonmetallic conduit.
- L. SCTE Society of Cable Telecommunications Engineers

1.3 SUBMITTALS

- A. Product Data: For surface raceways, wireways and fittings, floor boxes, hinged-cover enclosures, cabinets, and handholes.
- B. LEED Submittals:
 - 1. "Product Data for Credit IEQ 4.1" Subparagraph below applies to LEED-NC, LEED-CI, and LEED-CS; coordinate with requirements for solvent cements and adhesive primers.
 - 2. Product Data for Credit IEQ 4.1: For solvent cements and adhesive primers, documentation including printed statement of VOC content.
 - 3. "Laboratory Test Reports for Credit IEQ 4" Subparagraph below applies to LEED for Schools.
 - 4. Laboratory Test Reports for Credit IEQ 4: For solvent cements and adhesive primers, documentation indicating that products comply with the testing and product requirements of the California Department of Health Services' "Standard Practice for the Testing of

**KOPACHUCK STATE PARK
DAY USE DEVELOPMENT**

Volatile Organic Emissions from Various Sources Using Small-Scale Environmental Chambers."

- C. Coordination Drawings: Conduit routing plans, drawn to scale, on which the following items are shown and coordinated with work of other trades, using input from installers of items involved:
 - 1. Structural members in paths of conduit groups with common supports.
 - 2. HVAC and plumbing items and architectural features in paths of conduit groups with common supports.

PART 2 - PRODUCTS

2.1 GENERAL

- A. Listing and Labeling: Products shall be listed and labeled as defined in NFPA 70, by a qualified testing agency, and marked for intended location and application.
- B. Comply with NFPA 70 requirements.
- C. Minimum Raceway Size: 1/2-inch (16-mm) trade size.

2.2 METAL CONDUITS, TUBING, AND FITTINGS

- A. Manufacturers: Subject to compliance with requirements, provide products by one of the following
 - 1. AFC Cable Systems, Inc.
 - 2. Alflec Inc.
 - 3. Allied Tube & Conduit; a Tyco International Ltd. Co.
 - 4. Anamet Electrical, Inc.; Anaconda Metal Hose.
 - 5. Electri-Flex Company.
 - 6. Eaton
 - 7. Maverick Tube Corporation.
 - 8. O-Z/Gedney – Emerson
 - 9. Western Tube and Conduit Corporation.
 - 10. Wheatland Tube Company; a division of John Maneely Company.
- B. Conduit
 - 1. GRC: Comply with ANSI C80.1 and UL 6. Hot dipped zinc galvanized.
 - 2. ARC: Comply with ANSI C80.5 and UL 6A.
 - 3. IMC: Comply with ANSI C80.6 and UL 1242.
 - 4. FMC: Comply with UL 1; zinc-coated steel or aluminum.
 - 5. LFMC: Flexible steel conduit with PVC jacket and complying with UL 360.
 - 6. Fittings: Comply with NEMA FB 1 and UL 514B.
 - a. Hazardous (Classified) Locations: Comply with UL 886 and NFPA 70.
 - b. Material: Match conduit material.

**KOPACHUCK STATE PARK
DAY USE DEVELOPMENT**

- c. Type: Threaded.
- 7. Joint Compound: Approved, as defined in NFPA 70, by authorities having jurisdiction for use in conduit assemblies, and compounded for use to lubricate and protect threaded conduit joints from corrosion and to enhance their conductivity.
- C. EMT: Comply with ANSI C80.3 and UL 797.
 - 1. Couplings: Setscrew. Steel. May be constructed integral with tubing.
 - 2. Indentor, Tap On, and Die Cast fittings are not acceptable.
- D. Deflection/Expansion Fittings: Comply with UL 651, rated for environmental conditions where installed, and including flexible internal or external bonding jumper.

2.3 NONMETALLIC CONDUIT AND FITTINGS

- A. Manufacturers: Subject to compliance with requirements, provide products by one of the following
 - 1. AFC Cable Systems, Inc.
 - 2. Anamet Electrical, Inc.
 - 3. Arnco Corporation.
 - 4. Carlon
 - 5. CANTEX Inc.
 - 6. CertainTeed Corp.
 - 7. Condux International, Inc.
 - 8. ElecSYS, Inc.
 - 9. Electri-Flex Company.
 - 10. Lamson & Sessions; Carlon Electrical Products.
 - 11. Manhattan/CDT/Cole-Flex.
 - 12. RACO; a Hubbell company.
 - 13. Thomas & Betts Corporation.
- B. RNC
 - 1. Complying with NEMA TC 2 and UL 651. Type EPC-40-PVC.
 - 2. Fittings: Comply with NEMA TC 3; match to conduit or tubing type and material. Couplings may be constructed integral to raceway.
- C. Solvent cements and adhesive primers shall have a VOC content of 510 and 550 g/L or less, respectively, when calculated according to 40 CFR 59, Subpart D (EPA Method 24).
- D. Solvent cements and adhesive primers shall comply with the testing and product requirements of the California Department of Health Services' "Standard Practice for the Testing of Volatile Organic Emissions from Various Sources Using Small-Scale Environmental Chambers."

2.4 METAL WIREWAYS AND AUXILIARY GUTTERS

- A. Manufacturers: Subject to compliance with requirements, provide products by one of the following

**KOPACHUCK STATE PARK
DAY USE DEVELOPMENT**

1. Eaton-Cooper B-Line, Inc.
2. Hoffman; a Pentair company.
3. Husky
4. Schneider Electric.

B. Construction:

1. Sheet metal: sized and shaped as indicated,
2. Indoors: NEMA 250, Type 1, hinged cover.
3. Outdoors and unheated spaces: NEMA 250 Type 3R, Flanged and gasketed cover.
4. Stainless steel Type 4X in kitchens, sterilization rooms, laundry, washdown, and similar environments. Flanged and gasketed cover.

C. Fittings and Accessories: Include couplings, offsets, elbows, expansion joints, adapters, hold-down straps, end caps, and other fittings to match and mate with wireways as required for complete system.

D. Finish: Manufacturer's standard enamel finish.

2.5 SURFACE RACEWAYS

A. Surface Metal Raceways: Galvanized steel with snap-on covers complying with UL 5. Manufacturer's standard enamel finish and color.

B. Manufacturers: Subject to compliance with requirements, provide products by one of the following

1. Thomas & Betts Corporation.
2. Walker Systems, Inc.; Wiremold Company (The).
3. Wiremold Company (The); Electrical Sales Division.

2.6 BOXES, CABINETS, ENCLOSURES

A. Suitable and listed for the environment in which they are installed per UL 50 and NEMA 250.

1. Indoors: NEMA 250, Type 1.
2. Outdoors: NEMA 250 Type 3R, Flanged and gasketed cover.
3. Stainless steel Type 4X in kitchens, sterilization rooms, laundry, washdown, and similar environments. Flanged and gasketed cover.

B. Manufacturers: Subject to compliance with requirements, provide products by one of the following

1. Eaton.
2. EGS/Appleton Electric.
3. Erickson Electrical Equipment Company.
4. Pentair - Hoffman.
5. Hubbell Incorporated; Killark Electric Manufacturing Co. Division.
6. O-Z/Gedney; a unit of General Signal.
7. RACO; a Hubbell Company.

**KOPACHUCK STATE PARK
DAY USE DEVELOPMENT**

8. Robroy Industries, Inc.; Enclosure Division.
 9. Scott Fetzer Co; Adalet Division.
 10. Spring City Electrical Manufacturing Company.
 11. Thomas & Betts Corporation.
 12. Walker Systems, Inc.; Wiremold Company (The).
 13. Woodhead, Daniel Company; Woodhead Industries, Inc. Subsidiary.
- C. Sheet Steel Gage (Any Direction)
1. Less than 24": 14 USS gauge.
 2. Greater than 24": 12 USS gauge.
- D. Outlet and Device Boxes
1. Sheet Metal Outlet and Device Boxes: Comply with NEMA OS 1 and UL 514A.
 2. Cast-Metal Outlet and Device Boxes: Comply with NEMA FB 1, galvanized ferrous alloy for use with IMC and RMC, aluminum for use with ARC, Type FD.
 3. Nonmetallic Outlet and Device Boxes: Comply with NEMA OS 2 and UL 514C.
 4. Luminaire Outlet Boxes: Nonadjustable, designed for attachment of luminaire weighing 50 lb (23 kg). Outlet boxes designed for attachment of luminaires weighing more than 50 lb (23 kg) shall be listed and marked for the maximum allowable weight.
 5. Wall Device Box Dimensions: Minimum depth 2-1/8 inches. Gangable boxes are permitted.
 6. Floor Boxes
 - a. Fully adjustable, Sheet Metal or Cast Metal
 - b. Barrier to isolate power and communication outlets
 - c. Coverplate: Flush with floor with free swinging hinged door to access outlets. Finish: Gray.
 7. Box extensions used to accommodate new building finishes shall be of same material as recessed box.
- E. Pull and Junction Boxes
1. Small Sheet: NEMA OS 1.
 2. Cast-Metal: Comply with NEMA FB 1 and UL 1773, galvanized cast iron with gasketed cover.
 3. Access Cover as follows, unless otherwise indicated:
 - a. Screw Cover:
 - 1) Both cover dimensions less than 30 inches
 - 2) In line pulls with one cover dimension less than 16 inches
 - b. Either cover dimension greater than 30 inches: One or more hinged cover(s) with Latch.
- F. Cabinets and Enclosures
1. Finished inside and out with manufacturer's standard enamel.
 2. Access Door:

**KOPACHUCK STATE PARK
DAY USE DEVELOPMENT**

- a. Hinged with key latch to match panelboards.
 - b. Three-point latch when dual doors are in use or when hinged side exceeds 47 inches.
 - c. Gasketed
3. Metal barriers to separate wiring of different systems and voltage.
 4. Labeled with appropriate safety warnings.
 5. Accessory feet where required for freestanding equipment.
 6. Interior Panels: Steel; all sides finished with manufacturer's standard enamel. Removeable. Hardware and accessories suitable for supporting equipment.
 7. Lugs for grounding conductor(s) bonded to enclosure.
 8. Accessories:
 - a. Door Pocket for wiring diagram

2.7 HANDHOLES AND BOXES FOR EXTERIOR UNDERGROUND WIRING

- A. Manufacturers: Subject to compliance with requirements, provide products by one of the following:
 - a. Fogtite.
 - b. Oldcastle Precast, Inc.
 - c. H2
- B. Construction:
 1. Configuration: Designed for flush burial with open bottom.
 2. Cover:
 - a. Secured by tamper-resistant locking devices.
 - b. Nonskid finish shall have a minimum coefficient of friction of 0.50.
 - c. Legend: Molded lettering, "ELECTRIC.", "COMMUNICATION" or as otherwise appropriate to the system.
 3. Conduit Entrance Provisions: Conduit-terminating fittings shall mate with entering ducts for secure, fixed installation in enclosure wall.

2.8 PENETRATIONS

- A. Sleeves and seals associated with penetrations shall preserve the fire, thermal, water, or other rating of the penetrated element. Refer to Division 7 for Penetration Firestopping products.
- B. Wall Sleeves
 1. Steel Pipe Sleeves: ASTM A 53/A 53M, Type E, Grade B, Schedule 40, zinc coated, plain ends.
 2. Cast-Iron Pipe Sleeves: Cast or fabricated "wall pipe," equivalent to ductile-iron pressure pipe, with plain ends and integral water stop unless otherwise indicated.
 3. Sleeves for Conduits Penetrating Non-Fire-Rated Gypsum Board Assemblies: Galvanized-steel sheet; 0.0239-inch minimum thickness; round tube closed with welded longitudinal joint, with tabs for screw-fastening the sleeve to the board.

**KOPACHUCK STATE PARK
DAY USE DEVELOPMENT**

C. Compressive Seals:

1. Modular sealing device, designed for field assembly, to fill annular space between sleeve and raceway.
2. Manufacturers: Subject to compliance with requirements, provide products by one of the following:
 - a. Eaton/Crouse Hinds Link Seal.
 - b. Emerson/OZ Gedney
3. Sleeve or body casting: Cast iron, cast in place or core drill.
4. Sealing Elements EPDM rubber interlocking links shaped to fit surface of pipe. Include type and number required for pipe material and size of pipe.
5. Pressure Plates: Glass Reinforced Nylon or PVC coated stainless steel
6. Connecting Bolts and Nuts: 316 type Stainless steel of length required to secure pressure plates to sealing elements.
7. Completed assembly suitable rated at 20 psig or 40 feet of head.

D. Raceway Seal Fittings

1. General
 - a. For use with GRC or IMC. Sealant fill, wire fill provisions and orientation to match application, location and containment requirement.
 - b. Sealing system, may be removed for replacement of wire without affecting integrity of raceway system.
 - c. Sealant or sealing material furnished by fitting manufacturer to match application and be compatible with wire insulation type and thermal rating.
2. Foam Sealant: High expansion, two part urethane foam, 120 lb compressive strength and capable of withholding 22 feet of water head pressure. Complies with UL 94 fire rating HBF. American Polywater FST or equal.
3. Sealing Bushings: Slotted PVC coated steel discs; neoprene sealing ring; stainless steel socket head cap screws and washers. Custom holes drilled to accommodate cables. Stainless steel socket head screws. Hot dipped galvanized malleable or ductile iron locking collars. Seals against gas or fluid pressure of 50 psig. O-Z Gedney CSB series.
4. In Line Epoxy Cement Fill Fittings: For control of gasses and vapors, rated for 40% fill, liquid epoxy sealant, Emerson EY or EYAX series or equal.
5. Comply with UL 1203 for explosion proof and dust ignition proof environments.

PART 3 - EXECUTION

3.1 GENERAL

- A. Comply with NECA 1 and NECA 101 for installation requirements except where requirements on Drawings or in this article are stricter. Comply with NECA 102 for aluminum conduits.
- B. Comply with NFPA 70.
- C. Determine optimal raceway routes that result in coordination with all building systems. Determine pull box quantities, sizes and locations.

**KOPACHUCK STATE PARK
DAY USE DEVELOPMENT**

3.2 RACEWAY APPLICATION

- A. Outdoors: Apply raceway products as specified below unless otherwise indicated:
1. Exposed Conduit: GRC, IMC,.
 2. Concealed Conduit, Aboveground: GRC, IMC, EMT.
 3. Underground Conduit: PVC Type 40.
 4. Boxes and Enclosures, Aboveground: NEMA 250, Type 3R
 5. Handholes and Boxes, Underground: Provide boxes suitable for the load rating and the application.
- B. Indoors
1. Exposed, Not Subject to Physical Damage: EMT, IMC, GRC.
 2. Exposed and Subject to Damage: GRC, IMC.
 - a. Raceway locations include the following (any height):
 - 1) Loading dock.
 - 2) Gymnasiums
 - b. Raceway locations include the following, when below 8 feet above floor:
 - 1) Corridors used for traffic of mechanized carts, forklifts, and pallet-handling units.
 - 2) Mechanical rooms.
 3. Concealed in Ceilings and Interior Walls and Partitions: EMT.
 4. Damp or Wet Locations: GRC, IMC.
 5. Boxes and Enclosures: NEMA 250, Type 1, except use NEMA 250, Type 4X stainless steel in institutional and commercial kitchens, trash compactor areas, at sump pumps, and similar damp, wet or corrosive locations.
- C. In Slabs: Not permitted.
- D. Connection to Vibrating Equipment (Including Transformers and Hydraulic, Pneumatic, Electric Solenoid, or Motor-Driven Equipment): FMC, except use LFMC in fire pump rooms, damp locations, and wet locations.
- E. Raceway Fittings: Compatible with raceways and suitable for use and location.
1. Rigid and Intermediate Steel Conduit: Use threaded rigid steel conduit fittings unless otherwise indicated. Comply with NEMA FB 2.10.
 2. PVC Externally Coated, Rigid Steel Conduits: Use only fittings listed for use with this type of conduit. Patch and seal all joints, nicks, and scrapes in PVC coating after installing conduits and fittings. Use sealant recommended by fitting manufacturer and apply in thickness and number of coats recommended by manufacturer.
 3. EMT: Use setscrew fittings. Comply with NEMA FB 2.10. Cast metal fittings are not acceptable
 4. Flexible Conduit: Use only fittings listed for use with flexible conduit. Comply with NEMA FB 2.20.

**KOPACHUCK STATE PARK
DAY USE DEVELOPMENT**

- F. Install nonferrous conduit or tubing for circuits operating above 60 Hz. Where aluminum raceways are installed for such circuits and pass through concrete, install in nonmetallic sleeve.

3.3 INSTALLATION

- A. Install raceways parallel or perpendicular to structural building lines. Conceal conduit and EMT within finished walls, ceilings, and floors except as follows:
 - 1. In rooms without a dropped ceiling.
 - 2. In non-public spaces such as mechanical, electrical, communication rooms.
 - 3. Parking garages.
 - 4. Unless otherwise indicated.
- B. Do not route:
 - 1. Parallel horizontal runs of raceways within 6 inches (150 mm) or directly above flues, steam, or hot-water piping.
 - 2. Nonmetallic conduit where ambient temperature exceeds 120 deg F (49 deg C)
 - 3. Aluminum conduits or fittings in contact with concrete or earth.
- C. Complete raceway installation before starting conductor installation.
- D. Anchors and Supports:
 - 1. Positively attach raceways, boxes, and enclosures to structure, do not attach to supports for mechanical or other non-electrical systems.
 - 2. Support raceways within 12 inches (300 mm) of enclosures to which attached.
 - 3. Set boxes, enclosures, and cabinets plumb.
- E. Raceway Terminations:
 - 1. Cut conduit perpendicular to the length. For conduits 2-inch (53-mm) trade size and larger, use roll cutter or a guide to make cut straight and perpendicular to the length.
 - 2. Locations Subject to Moisture or Vibration: Use insulating bushings to protect conductors.
 - 3. Terminate threaded conduits into threaded hubs or with locknuts on inside and outside of boxes or cabinets. Install bushings on conduits up to 1-1/4-inch (35mm) trade size and insulated throat metal bushings on 1-1/2-inch (41-mm) trade size and larger conduits terminated with locknuts. Install insulated throat metal grounding bushings on service conduits.
 - 4. Install raceways square to the enclosure and terminate at enclosures with locknuts. Install locknuts hand tight plus 1/4 turn more.
 - 5. Do not rely on locknuts to penetrate nonconductive coatings on enclosures. Remove coatings in the locknut area prior to assembling conduit to enclosure to assure a continuous ground path.
 - 6. Threaded Conduit Joints, Exposed to Wet, Damp, Corrosive, or Outdoor Conditions: Apply listed compound to threads of raceway and fittings before making up joints. Follow compound manufacturer's written instructions.
- F. Install pull wires in empty raceways. Use polypropylene or monofilament plastic line with not less than 200-lb tensile strength. Leave at least 12 inches of slack at each end of pull wire. Cap plug or compressive seal underground raceways designated as spare at point of below grade entry into building or at first pulling access point.

**KOPACHUCK STATE PARK
DAY USE DEVELOPMENT**

G. Stub-ups:

1. Above Recessed Ceilings: Use a raceway bushing or insulated fitting to terminate stub-ups not terminated in hubs or in an enclosure.
2. Through slab, comply with either:
 - a. Arrange stub-ups so curved portions of bends are not visible above finished slab.
 - b. Terminate conduit at threaded GRC coupling with top of coupling 1/8" below top of slab.

H. Outlet and Device Boxes:

1. Mount outlet boxes at heights indicated on Drawings. If mounting heights of boxes are not individually indicated, give priority to ADA requirements. Install wall outlet boxes with height measured to center of box unless otherwise indicated.
2. Recessed Boxes in Masonry Walls: Saw-cut opening for box in center of cell of masonry block and install box flush with surface of wall. Prepare block surfaces to provide a flat surface for a rain-tight connection between box and cover plate or supported equipment and box.
3. Horizontally separate boxes mounted on opposite sides of walls, so they are not in the same vertical channel. Do not compromise wall ratings for fire and sound separation.
4. Locate boxes so that cover or plate will not span different building finishes.
5. Support boxes of three gangs or more from more than one side by spanning two framing members or mounting on brackets specifically designed for the purpose.
6. Box construction and size to match device requirements. Where device is furnished under this, or other Divisions of this specification obtain requirements prior to roughing in.
7. Set floor boxes level and adjust to match finished floor surface.
8. Provide cast outlet boxes in exterior, wet, or cast in concrete locations.

I. Surface Raceways:

1. Install surface raceways only where indicated.
2. Install surface raceway with a minimum 2-inch (50-mm) radius control at bend points.
3. Secure surface raceway with screws or other anchor-type devices at intervals not exceeding 48 inches and with no less than two supports per straight raceway section. Support surface raceway according to manufacturer's written instructions. Tape and glue are not acceptable support methods.

J. Movement:

1. General
 - a. Select raceway elements to accommodate the expected movement. Set initial position of raceway movement element as appropriate to accommodate ultimate worst case movement.
 - b. Install raceway supports to allow for expansion movement.
 - c. Provide bonding jumper for fittings without a continuous ground path.
2. Raceway thermal performance:

KOPACHUCK STATE PARK DAY USE DEVELOPMENT

- a. Install in each run of aboveground metallic raceway that is located where environmental temperature change may exceed 100 deg F (55 deg C) and that has straight-run length that exceeds 100 feet (30 m).
 - b. Install fitting(s) that provide expansion and contraction for at least 0.000078 inch per foot of length of straight run per deg F (0.0115 mm per meter of length of straight run per deg C) of temperature change for metal conduits.
3. Structural and Architectural Elements: Install expansion fittings or flexible raceways at all locations where raceways cross building or structure expansion joints. Install each expansion-joint fitting with position, mounting, and piston setting selected according to manufacturer's written instructions for conditions at specific location at time of installation.
 4. Where piston fittings are used provide slack conductor in adjacent pull boxes or equipment to alleviate stress on conductor terminations during expansion joint movement.
- K. Flexible Conduit Connections: Comply with NEMA RV 3. Use a maximum of 72 inches of flexible conduit for recessed and semi-recessed luminaires, equipment subject to vibration, noise transmission, transformers and motors.

3.4 UNDERGROUND RACEWAY SYSTEMS

- A. Refer to Section 260540 – Electrical Site Work trenching and backfill. Excavate trench bottom to provide firm and uniform support.
- B. Direct-Buried Conduit:
 1. Trade size minimum: 1 inch, except $\frac{3}{4}$ inch may be used for runs shorter than 30 feet.
 2. Comply with manufacturer's written instructions for solvent welding RNC and fittings.
 3. After installing conduit, backfill and compact soil. Start at tie-in point, and work toward end of conduit run, leaving conduit at end of run free to move with expansion and contraction as temperature changes during this process. Firmly hand tamp backfill around conduit to provide maximum supporting strength. After placing controlled backfill to within 12 inches of finished grade, make final conduit connection at end of run and complete backfilling with normal compaction.
 4. Install manufactured rigid steel conduit elbows for stub-ups at poles and equipment and at building entrances through floor. Cover exterior of conduit from 3 inches above grade to 12 inches below grade with a bitumastic tape or coating.
 - a. Couple steel conduits to ducts with adapters designed for this purpose, and encase coupling with 3 inches of concrete for a minimum of 12 inches on each side of the coupling.
 - b. For stub-ups at equipment mounted on outdoor concrete bases and where conduits penetrate building foundations, extend steel conduit horizontally a minimum of 60 inches from edge of foundation or equipment base. Install insulated grounding bushings on terminations at equipment.
 5. Underground Warning Tape: Comply with requirements in Division 26 Section "Identification for Electrical Systems."

**KOPACHUCK STATE PARK
DAY USE DEVELOPMENT**

6. Raceways routed under slab on grade shall be kept a minimum of six inches below the underside of the slab.

C. Handholes and Boxes

1. Install handholes and boxes level and plumb and with orientation and depth coordinated with connecting conduits to minimize bends and deflections required for proper entrances.
2. Unless otherwise indicated, support units on a level bed of crushed stone or gravel, graded from 1/2-inch sieve to No. 4 sieve and compacted to same density as adjacent undisturbed earth.
3. Elevation: In paved areas, set so cover surface will be flush with finished grade. Set covers of other enclosures 1 inch above finished grade. Provide offset risers to match slope of cover to slope of finished grade.
4. Install handholes with bottom below frost line.
5. Field-cut openings for conduits according to enclosure manufacturer's written instructions. Cut wall of enclosure with a tool designed for material to be cut. Size holes for terminating fittings to be used, and seal around penetrations after fittings are installed.

3.5 SEALS

- A. Select seals as appropriate for the element (ie: liquids, gasses, dust, and/or vapor) the seal is isolating.
- B. Follow manufacturer's instructions when installing sealants and seal fittings.
- C. Location:
 1. Seal fitting shall be accessible.
 2. Locate seal fittings so no fittings or boxes are between the seal and the element requiring isolation.
 3. For concealed raceways, install each fitting in a flush steel box with a blank cover plate having a finish like that of adjacent plates or surfaces.
- D. Transition to RMC or IMC where required by code or seal fitting application.
- E. Seal the following points:
 1. Where raceways pass from warm to cold locations:
 - a. Boundaries of refrigerated spaces
 - b. Boundaries between heated and unheated spaces.
 2. Raceway connections to continually wet environments such as sumps and wells.
 3. To limit transmittance of hazardous liquids, gasses, dust, and/or vapors.
 4. Where raceways 2" and larger rise from below grade to terminate at stand or slab mounted exterior utilization equipment.

**KOPACHUCK STATE PARK
DAY USE DEVELOPMENT**

3.6 PENETRATIONS

- A. Penetrate fire barriers, smoke barriers, vapor barriers, acoustic barriers, waterproofing, roofing materials, floors, walls, foundations, and other rated architectural and structural elements and assemblies in a manner that preserves the integrity of the rating and the intended performance.
 - 1. Install firestopping at penetrations of fire-rated floor and wall assemblies. Comply with requirements in Division 07 requirements for penetration firestopping.
 - 2. Roof penetrations shall be made in accordance with the recommendations of the roofing system supplier and shall not compromise the roofing warranty.

- B. Penetration of below grade walls and slab on grade:
 - 1. Comply with either of the following:
 - a. Cast raceways into wall or slab.
 - b. Provide sleeve and compression seal between sleeve and raceway. The compression seal manufacturer shall have documentation indicating that the sleeve is compatible with the seal.

 - 2. Seal interior of raceways:
 - a. Seal Bushings: Utilize at all penetrations where other seals are not specified. Provide a pull box for sealing bushing(s) at point of entry when end use equipment is located away from wall or elevated above slab.

 - b. Foam Sealant:
 - 1) For phase conductor sizes #2 AWG and smaller.
 - 2) For feeder (not service) phase conductor sizes larger than #2AWG, where no portion of the raceway entering the building or equipment travels below grade at a height that is above the point of entry or the point of raceway termination at the equipment.
 - 3) Apply foam sealant at raceway entry point into first interior and exterior pull point.
 - 4) Apply foam sealant at all raceways entering handholes and manholes.

 - c. Below slab raceways are not required to be sealed when the following conditions are met:
 - a) The raceway travels below slab from one interior building point to another, and the slab entrance and exit points are at same height.
 - b) The raceway horizontal travel distance is less than 20 feet or the raceway is less than 2" in diameter and the horizontal travel distance is less than 100 feet.

3.7 PROTECTION

- A. Protect coatings, finishes, and cabinets from damage and deterioration.
 - 1. Repair damage to galvanized finishes with zinc-rich paint recommended by manufacturer.

**KOPACHUCK STATE PARK
DAY USE DEVELOPMENT**

2. Repair damage to PVC coatings or paint finishes with matching touchup coating recommended by manufacturer.

END OF SECTION 260533

**KOPACHUCK STATE PARK
DAY USE DEVELOPMENT**

SECTION 260540 - ELECTRICAL SITE WORK

PART 1 - GENERAL

1.1 RELATED DOCUMENTS

- A. Drawings and general provisions of the Contract, including General Conditions and Division 1 Specification Sections, apply to this Section.
- B. Comply with OSHA standards and criteria.

PART 2 - PRODUCTS

2.1 CONCRETE MIXES

- A. Concrete shall be American Public Works Association Class 3000, manufactured with 1/2-inch aggregate and ASTM C150 Type 1 or Type 11 cement.

2.2 ASPHALT

- A. Asphalt shall match the standard specifications of the local municipality for public roads adjoining the site.

2.3 CRUSHED ROCK

- A. Crushed rock shall be 1 1/4" minus unless smaller is required for bedding material.

2.4 SAND

- A. Sand shall be clean and washed building sand.

2.5 TOPSOIL

- A. Finish course of topsoil shall be adequate to support replanted or replacement vegetation. Sandy loam, garden mulch, 1/2" screen, less than 30% mineral aggregates.

2.6 SOD

- A. New sod shall be mature, densely rooted grass 99% free of weeds and objectionable grasses.

**KOPACHUCK STATE PARK
DAY USE DEVELOPMENT**

2.7 PLANTS

- A. Plants shall be obtained from a local commercial nursery and be of the same type and maturity as the existing plants.
 - 1. Use native, non-invasive and drought resistant plants to reduce water use and limit negative impact on surrounding existing species.
 - 2. From a green nursery that limits use of fertilizers.
 - 3. One year warranty

PART 3 - EXECUTION

3.1 GENERAL

- A. Prior to completion of work Contractor shall return site to the condition it was in before work commenced.
- B. Where existing materials must be removed to support electrical site work replacement materials shall be of the same type and quality unless type and quality are defined herein.

3.2 EXISTING UTILITIES

- A. The existing utilities shown on the contract drawings have been plotted from available records. No guarantee is made to the accuracy of the locations indicated and is shown for whatever benefit the Contractor may derive therefrom.
- B. Contact all serving utilities and have them locate their lines prior to commencing work. Forty-eight (48) hours prior to commencing work telephone "Call Before You Dig" at 1-800-424-5555. The Contractor shall also have the Owner locate all utility lines prior to commencing work.
- C. Protect shown, visible and located utilities from damage. Promptly repair all active shown, visible and located utilities damaged by construction. This repair shall be made solely at the expense of the Contractor.
- D. When despite all care and caution damage occurs to active utilities not visible, located or shown on the contract documents, the Contractor shall immediately obtain a decision as to repair. When so directed the repair shall be made immediately by the Contractor whose trade is involved. The contract price shall not change when the conditions outlined above and utmost possible care and caution have not been followed.
- E. Adjust the depth of electrical utilities to avoid existing utilities with no change to contract price.
- F. Use metal detectors to search for unknown utilities in proposed route of electrical systems.

**KOPACHUCK STATE PARK
DAY USE DEVELOPMENT**

3.3 SECURING SITE WORK

- A. The Contractor is solely responsible for securing all electrical site work with adequate barriers, warning indicators and shoring.

3.4 TRENCHING

- A. Trenching shall be to depths as required by code, the installation, or as shown on the drawings. Trench width and length as required by the installation or as shown.
- B. Trench bottom shall be free of debris and graded smooth. Where trench bottom is rock, or rocky, or contains debris larger than 1", or material with sharp edges, Contractor shall over excavate 3" and fill with 3" of sand or backfill with native materials passed through one inch sieve.
- C. Provide 1'-0" minimum separation between new electrical utilities and other utilities, except gas lines shall be 1'-0" both vertical and horizontal and shall be 3'-0" (horizontal) for all water service lines.
- D. All crossings of concrete or asphalt shall be performed only after the surface material has been saw cut to required width and removed.

3.5 EXCAVATIONS

- A. Provide excavations as required for installation intended or as shown.
- B. Saw cut concrete and asphalt surfaces prior to excavating.
- C. Excavation bottom shall be free of debris and graded smooth. Where bottom is rock, or rocky, or contains debris larger than 1", or material with sharp edges, over excavate 6" and fill with 6" sand or backfill with native materials passed through one inch sieve.
- D. Conform to utility requirements for excavation and vault installation in addition to contract document requirements where excavations are for installing utility companies' vaults.
- E. Provide, operate and maintain all pumps or other dewatering equipment required for control of water in trenches and excavations for electrical site work during the entire construction period.
- F. Provide shoring as required by trenching and excavating to secure site work.

3.6 BACKFILL, BEDDING AND COMPACTION

- A. Backfill around raceways per 260533 – Raceways and Boxes for Electrical Systems.

**KOPACHUCK STATE PARK
DAY USE DEVELOPMENT**

- B. Bedding and backfill around precast vaults and handholes shall be in accordance with manufacturer's recommendations.
 - 1. Where manufacturer has no recommendations provide 0'-6" of 1/2" minus pea gravel or sand bedding for all vaults, and any handholes larger than 3'-0" x 3'-0".
 - 2. For handholes smaller than 3'-0" x 3'-0" provide 0'-3" pea gravel or sand. Backfill shall extend at least 6" from handhole.
- C. All other backfill shall be free of organic debris and inorganic materials larger than 6" in diameter.
- D. Place all backfill material so as to obtain a minimum degree of compaction of 95 percent of the maximum density at optimum moisture content. Moisten backfill material as required to obtain proper compaction.
- E. Broken pavement, concrete, and vegetative materials shall not be used for backfill.
- F. Within the one-year guarantee period, re-fill, compact and re-finish all settled areas to grade.

3.7 WASTE MATERIAL DISPOSAL

- A. Promptly remove from the site and legally dispose of all materials from trenching and excavation which are remaining after backfilling and compaction.

3.8 SURFACE REFINISHING

- A. Refinish every disturbed surface to its' original condition and elevation. Preserve sod and topsoil removed during excavation and reinstall after backfilling is completed. Replace sod that is damaged or unusable with sod of equal or better quality to that removed. When the surface is disturbed in a newly seeded area, re-seed the restored surface with the same quantity and formal of seed as that used in the original seeding, Provide topsoil, fertilizer, liming, seeding, sodding, sprigging or mulching as required to match existing original condition.
- B. Replace all planted materials not surviving 90 days after contract acceptance at Contractor's own expense.
- C. Return after one year and refinish all settled areas to grade.

3.9 CARE OF PLANTS AND TREES

- A. Unless specifically noted for demolition, remove, and safely store all plants and trees in trenching or excavation areas prior to commencing site work.
- B. Where plants and trees fail to survive storage replace with like kind, quality, and maturity.

**KOPACHUCK STATE PARK
DAY USE DEVELOPMENT**

3.10 PAVED SURFACE REPAIRS

- A. Where trenches, pits or other excavations are made in existing roadways and other areas of pavement where surface treatment of any kind exists, restore such surface treatment or pavement to the same thickness and in the same kind as originally existed. Match and tie into the adjacent and surrounding existing surfaces. Seal all joints between new and existing materials.

END OF SECTION 260540

**KOPACHUCK STATE PARK
DAY USE DEVELOPMENT**

SECTION 260553 - IDENTIFICATION FOR ELECTRICAL SYSTEMS

PART 1 - GENERAL

1.1 RELATED DOCUMENTS

- A. Drawings and general provisions of the Contract, including General Conditions and Division 01 Specification Sections, apply to this Section.

1.2 SUMMARY

- A. Section Includes:

- 1. Equipment identification nameplates.
- 2. Identification for conductors, cables AC and MC cables
- 3. Identification for raceways.
- 4. Underground-line warning tape.
- 5. Warning labels and signs.
- 6. Instruction signs.
- 7. Receptacle Identification Labels
- 8. Miscellaneous identification products.

1.3 REFERENCES

- A. American National Standards Institute (ANSI):

- 1. ANSI A13.1 "Scheme for Identification of Piping Systems"

- B. Occupational Safety and Health Administration (OSHA). 29 CFR - Labor Chapter XVII Part 1910-145 "Occupational and Safety Health Standards" 1992.

- C. Washington Administrative Code (WAC) 296-24 Part B-2 "Safety Color Code for Marking Physical Hazards."

1.4 ACTION SUBMITTALS

- A. Product Data: For each electrical identification product indicated.
- B. Samples: For each type of label and sign to illustrate size, colors, lettering style, mounting provisions, and graphic features of identification products.
- C. Identification Schedule: An index of nomenclature of electrical equipment and system components used in identification signs and labels.

**KOPACHUCK STATE PARK
DAY USE DEVELOPMENT**

1.5 QUALITY ASSURANCE

- A. Comply with ANSI A13.1 and IEEE C2.
- B. Comply with NFPA 70.
- C. Comply with 29 CFR 1910.144 and 29 CFR 1910.145.
- D. Comply with ANSI Z535.4 for safety signs and labels.
- E. Adhesive-attached labeling materials, including label stocks, laminating adhesives, and inks used by label printers, shall comply with UL 969.

1.6 COORDINATION

- A. Coordinate identification names, abbreviations, colors, and other features with requirements in other Sections requiring identification applications, Drawings, Shop Drawings, manufacturer's wiring diagrams, and the Operation and Maintenance Manual; and with those required by codes, standards, and 29 CFR 1910.145. Use consistent designations throughout Project.
- B. Note that equipment names and room numbers shown on the Contract Drawings may not be final names and numbers. Confirm all final naming prior to label manufacture.
- C. Coordinate installation of identifying devices with completion of covering and painting of surfaces where devices are to be applied.
- D. Coordinate installation of identifying devices with location of access panels and doors.
- E. Install identifying devices before installing acoustical ceilings and similar concealment.

PART 2 - PRODUCTS

2.1 EQUIPMENT NAMEPLATES

- A. Materials:
 - 1. Engraved plastic laminate - three-layer laminated plastic with punched or drilled holes for screw mounting.
 - 2. Self-Adhesive, Engraved, Laminated Acrylic or Melamine Label: Adhesive backed
 - 3. Adhesive Film Label: Machine printed, in black, by thermal transfer or equivalent process.
 - 4. Adhesive Film Label with Clear Protective Overlay: Machine printed, in black, by thermal transfer or equivalent process. Overlay shall provide a weatherproof and UV-resistant seal for label.
 - 5. Stenciled Legend: In nonfading, waterproof, black ink or paint. Minimum letter height shall be 1 inch (25 mm)

**KOPACHUCK STATE PARK
DAY USE DEVELOPMENT**

B. Dimension

1. Nameplate minimum of 1 3/4" high by 5" wide.
2. Lettering height for panel or equipment identifier @ 1/4".
3. Lettering height for remaining lines @ 1/8" high with 1/8" spacing between lines.
4. Normal System: White letters on black background.

C. Panelboard Nameplates

1. Provide engraved plastic nameplate for each new panelboard with the following information:

Line 1: Panelboard Name

Line 2: Source from which panel is fed (e.g.Fed From SWBD 4N2A)

Line 3: Transfer switch from which panel is fed (if applicable)

Line 4: Amps, voltage, phase and wire

2.2 RACEWAY IDENTIFICATION MATERIALS

- A. Comply with ANSI A13.1, for minimum lettering size and for minimum length of color field for each raceway size.
- B. Color for Raceway Carrying Circuits at 600 V or Less:
 1. [Black letters on an orange field] <Insert color scheme>.
- C. Self-Adhesive Vinyl Labels for Raceways Carrying Circuits at 600 V or Less: Preprinted, flexible label laminated with a clear, weather- and chemical-resistant coating and matching wrap-around adhesive tape for securing ends of legend label.
- D. Snap-Around Labels for Raceways Carrying Circuits at 600 V or Less: Slit, pretensioned, flexible, preprinted, color-coded acrylic sleeve, with diameter sized to suit diameter of raceway or cable it identifies and to stay in place by gripping action.
- E. Snap-Around, Color-Coding Bands for Raceways Carrying Circuits at 600 V or Less: Slit, pretensioned, flexible, solid-colored acrylic sleeve, 2 inches long, with diameter sized to suit diameter of raceway or cable it identifies and to stay in place by gripping action.
- F. Metal Tags: Brass or aluminum, 2 by 2 by 0.05 inch, with stamped legend, punched for use with self-locking cable tie fastener.

2.3 UNDERGROUND-LINE WARNING TAPE

- A. Tape:

**KOPACHUCK STATE PARK
DAY USE DEVELOPMENT**

1. Recommended by manufacturer for the method of installation and suitable to identify and locate underground electrical [and communications] utility lines.
2. Printing on tape shall be permanent and shall not be damaged by burial operations.
3. Tape material and ink shall be chemically inert, and not subject to degrading when exposed to acids, alkalis, and other destructive substances commonly found in soils.

B. Color and Printing:

1. Comply with ANSI Z535.1 through ANSI Z535.5.
2. Edit or delete paragraph below as applicable.
3. Inscriptions for Red-Colored Tapes: ELECTRIC LINE, HIGH VOLTAGE.
4. Edit or delete paragraph below as applicable.
5. Inscriptions for Orange-Colored Tapes: TELEPHONE CABLE, CATV CABLE, COMMUNICATIONS CABLE, OPTICAL FIBER CABLE.

C. Non-Conducting Protective Tapes

1. Pigmented polyolefin, bright-colored, continuous-printed with the inscription noted above compounded for direct-burial service.
2. Thickness: 4 mils (0.1 mm).

D. Protective Tapes Suitable for Conductive or Inductive Tracing.

1. Detectable three-layer laminate, consisting of a printed pigmented polyolefin film, a solid aluminum-foil core, and a clear protective film that allows inspection of the continuity of the conductive core, bright-colored, continuous-printed with the inscription indicated above, compounded for direct-burial service.
2. Overall Thickness: 5 mils.
3. Foil Core Thickness: 0.35 mil.

2.4 POSTED DRAWINGS

- A. Electrical One-line or Risers: Print electrical one-line/riser diagrams on 20 lb. bond paper. (Blue print paper is not acceptable). Reduce drawings to approximately 1/2 size using Xerox reduction process. Contact engineer to obtain updated original plans for printing.
- B. Mounting Frames: Extruded aluminum, 4 point screw mount with 1/8" clear plexi-glass cover.

2.5 WARNING LABELS AND SIGNS

- A. Comply with NFPA 70 and 29 CFR 1910.145.
- B. Self-Adhesive Warning Labels: Factory-printed, multicolor, pressure-sensitive adhesive labels, configured for display on front cover, door, or other access to equipment unless otherwise indicated.
- C. Baked-Enamel Warning Signs:
 1. Preprinted aluminum signs punched or drilled for fasteners, with colors, legend, and size required for application.

**KOPACHUCK STATE PARK
DAY USE DEVELOPMENT**

2. 1/4-inch grommets in corners for mounting.
3. Nominal size, 7 by 10 inches.

D. Warning label and sign shall include, but are not limited to, the following legends:

1. Multiple Power Source Warning: "DANGER - ELECTRICAL SHOCK HAZARD - EQUIPMENT HAS MULTIPLE POWER SOURCES."
2. Workspace Clearance Warning: "WARNING - OSHA REGULATION - AREA IN FRONT OF ELECTRICAL EQUIPMENT MUST BE KEPT CLEAR FOR 36 INCHES"

2.6 INSTRUCTION SIGNS

- A. Engraved, laminated acrylic or melamine plastic, minimum 1/16 inch (1.6 mm) thick for signs up to 20 sq. inches and 1/8-inch-thick for larger sizes.
1. Engraved legend with black letters on white face.
 2. Punched or drilled for mechanical fasteners.
 3. Framed with mitered acrylic molding and arranged for attachment at applicable equipment.
- B. Adhesive Film Label: Machine printed, in black, by thermal transfer or equivalent process. Minimum letter height shall be 3/8 inch.
- C. Adhesive Film Label with Clear Protective Overlay: Machine printed, in black, by thermal transfer or equivalent process. Minimum letter height shall be 3/8 inch. Overlay shall provide a weatherproof and UV-resistant seal for label.

2.7 CABLE TIES

- A. General-Purpose Cable Ties: Fungus inert, self-extinguishing, one piece, self-locking, Type 6/6 nylon.
1. Minimum Width: 3/16 inch.
 2. Tensile Strength at 73 deg F, according to ASTM D 638: 12,000 psi.
 3. Temperature Range: Minus 40 to plus 185 deg F.
 4. Color: Black except where used for color-coding.

2.8 MISCELLANEOUS IDENTIFICATION PRODUCTS

- A. Paint: Comply with requirements in Division 09 painting Sections for paint materials and application requirements. Select paint system applicable for surface material and location (exterior or interior).
- B. Fasteners for Labels and Signs: Self-tapping, stainless-steel screws or stainless-steel machine screws with nuts and flat and lock washers.

**KOPACHUCK STATE PARK
DAY USE DEVELOPMENT**

PART 3 - EXECUTION

3.1 INSTALLATION - GENERAL

- A. Verify identity of each item before installing identification products.
- B. Location: Install identification materials and devices at locations for most convenient viewing without interference with operation and maintenance of equipment.
- C. Apply identification devices to surfaces that require finish after completing finish work.
- D. Self-Adhesive Identification Products: Clean surfaces before application, using materials and methods recommended by manufacturer of identification device.
- E. Attach signs and plastic labels that are not self-adhesive type with mechanical fasteners appropriate to the location and substrate.
- F. Cable Ties: For attaching tags. Use general-purpose type, except as listed below:
 - 1. Outdoors: UV-stabilized nylon.
 - 2. In Spaces Handling Environmental Air: Plenum rated.
- G. Painted Identification: Comply with requirements in Division 09 painting Sections for surface preparation and paint application.

3.2 EQUIPMENT IDENTIFICATION:

- A. Label and mark equipment per all applicable codes.
- B. On each unit of equipment, install unique designation nameplate that is consistent with naming used in wiring diagrams, schedules, and the Operation and Maintenance Manual.
- C. In addition to equipment listed in Part 2 provide nameplates for:
 - 1. Access doors for concealed electrical devices
 - 2. Transformers
 - 3. Substations
 - 4. Enclosed over-current protective devices
 - 5. Electrical cabinets, enclosures, and terminal cabinets
 - 6. Contactors
 - 7. Variable speed drives
 - 8. Battery -inverters, battery racks, UPS equipment
 - 9. Power-generating units
 - 10. Monitoring and control panels and equipment
- D. Confirm all final naming prior to label manufacture.
- E. Labeling Instructions:
 - 1. Indoor Equipment: Self-adhesive, engraved, laminated acrylic or melamine label.

KOPACHUCK STATE PARK DAY USE DEVELOPMENT

2. Outdoor Equipment: Engraved, laminated acrylic or melamine label with screw fasteners.
3. Elevated Components: Increase sizes of labels and letters to those appropriate for viewing from the floor.
4. Unless provided with self-adhesive means of attachment, fasten labels with appropriate mechanical fasteners that do not change the NEMA or NRTL rating of the enclosure.

3.3 CIRCUIT CONDUCTOR IDENTIFICATION

A. Power-Circuit Conductor Identification, 600 V or Less:

1. For conductors in vaults, pull and junction boxes, manholes, and handholes, use color-coding conductor tape to identify the phase.
2. Color-Coding for Phase and Voltage Level Identification, 600 V or Less: Use colors listed below for ungrounded service, feeder and branch-circuit conductors.
 - a. Color shall be factory applied or field applied for sizes larger than No. 8 AWG, if authorities having jurisdiction permit.
 - b. Colors for 208/120-V Circuits:
 - 1) Phase A: Black.
 - 2) Phase B: Red.
 - 3) Phase C: Blue.
 - 4) Neutral: White
 - 5) Equipment Ground: Green
 - 6) Isolated Ground: Green with yellow tracer
 - c. Colors for 480/277-V Circuits:
 - 1) Phase A: Brown.
 - 2) Phase B: Orange.
 - 3) Phase C: Yellow.
 - 4) Neutral: Gray
 - 5) Equipment Ground: Green
 - 6) Isolated Ground: Green with yellow tracer
 - d. Field-Applied, Color-Coding Conductor Tape: Apply in half-lapped turns for a minimum distance of 6 inches from terminal points and in boxes where splices or taps are made. Apply last two turns of tape with no tension to prevent possible unwinding. Locate bands to avoid obscuring factory cable markings.
3. Conductors to Be Extended in the Future: Attach self-adhesive label to conductors and list source.

B. Auxiliary Electrical Systems Conductor Identification: Identify field-installed alarm, control, and signal connections.

1. Identify conductors, cables, and terminals in enclosures and at junctions, terminals, and pull points. Identify by system and circuit designation.
2. Use system of marker tape designations that is uniform and consistent with system used by manufacturer for factory-installed connections.
3. Coordinate identification with Project Drawings, manufacturer's wiring diagrams, and the Operation and Maintenance Manual.

**KOPACHUCK STATE PARK
DAY USE DEVELOPMENT**

3.4 WORKING CLEARANCE IDENTIFICATION

- A. Workspace Indication: Install floor marking tape to show working clearances in the direction of access to live parts. Workspace shall be as required by NFPA 70 and 29 CFR 1926.403 unless otherwise indicated.
- B. Do not install at flush-mounted panelboards and similar equipment in finished spaces.

3.5 WARNING SIGNS

- A. Warning Labels for Indoor Cabinets, Boxes, and Enclosures for Power and Lighting:
 - 1. Comply with 29 CFR 1910.145.
 - 2. Identify system voltage with black letters on an orange background.
 - 3. Apply to exterior of door, cover, or other access.
 - 4. For equipment with multiple power or control sources, apply to door or cover of equipment including, but not limited to, the following:
 - a. Power transfer switches.
 - b. Controls with external control power connections.

END OF SECTION 260553

**KOPACHUCK STATE PARK
DAY USE DEVELOPMENT**

SECTION 260923 - LIGHTING CONTROL DEVICES

PART 1 - GENERAL

1.1 RELATED DOCUMENTS

- A. Drawings and general provisions of the Contract, including General Conditions and Division 1 Specification Sections, apply to this Section.
- B. Related Sections include the following:
 - 1. List below only products that the reader might expect to find in this Section but are specified elsewhere.
 - 2. Section 260519 Low Voltage Electrical Power Conductors and Cables
 - 3. Section 265100 Interior Lighting
 - 4. Section 265600 Exterior Lighting

1.2 SUMMARY

- A. This Section includes the following lighting control devices:
 - 1. Snap switches and wall box dimmers
 - 2. Indoor occupancy sensors
 - 3. Outdoor motion sensors
 - 4. Outdoor photocell switches
 - 5. Time switches
 - 6. Multi-pole contactors
 - 7. Control Relays

1.3 DEFINITIONS

- A. LED: Light-Emitting Diode
- B. PIR: Passive Infrared
- C. DT: Dual Technology

1.4 SUBMITTALS

- A. Make submittals in accordance with Section 260500 - Common Work Results For Electrical.
- B. Product Data: Provide clearly marked and legible data sheets for each item of equipment being installed on the project. This shall include each major replaceable component that is part of a larger assembly. Data sheets should clearly indicate:
 - 1. Equipment manufacturer, make, model number, size, nameplate data, etc.
 - 2. Dimensional and performance data for specific unit provided as appropriate

**KOPACHUCK STATE PARK
DAY USE DEVELOPMENT**

3. Required environmental operating parameters
 4. UL, FM and ETL listing and category
 5. Manufacturer contact information including address, telephone number, facsimile number, email address, web site address and contact person or persons.
 6. Local manufacturer's representative contact information including address, telephone number, facsimile number, email address, web site address and contact person or persons.
- C. Shop Drawings: Show installation details for occupancy and light-level sensors.
1. Lighting plan showing location, orientation, and coverage area of each sensor. This plan shall take into consideration the size and use of each space as well as the specific capabilities of submitted manufacturer's equipment to provide proper coverage to the areas of control.
 2. Interconnection diagrams showing field-installed wiring.
- D. Label List: Submit list of proposed text for all labels prior to manufacturing for review and approval by Owner's representative.
- E. Warranty: Submit a copy of product warranty that complies with contract document requirements. Where these requirements exceed manufacturer's standard warranty include cost of extended warranty in contract price.
- F. Maintenance Requirements: Submit maintenance requirements manual or guidelines. This document should detail the requirements necessary to comply with the warranty. This is required for the submittal process and is in addition to the O&M requirements.
- G. Samples: Provide sample devices and finishes plus other samples when requested, as part of the submittal process.
- H. Commissioning Checklist: Submit a copy of the proposed commissioning checklist to be utilized for this project.
- I. Commissioning Results: Submit a copy of the completed commissioning documents.
- 1.5 COORDINATION
- A. Coordinate layout and installation of ceiling-mounted devices with other construction that penetrates ceilings or is supported by them, including light fixtures, HVAC equipment, fire-suppression system, and partition assemblies.
- 1.6 QUALITY ASSURANCE
- A. Qualifications
1. Manufacturer shall have been in the business of manufacturing and providing service for lighting control equipment for similar capabilities and size, under the same name and ownership, for a minimum of three years preceding bid date of the project.
 2. All components and assemblies shall be factory pre-tested prior to installation.
 3. Factory trained technicians shall be on site for start-up, commissioning and training.

**KOPACHUCK STATE PARK
DAY USE DEVELOPMENT**

4. Factory trained technicians shall be available for telephone support twenty-four (24) hours a day, seven (7) days a week.
5. Lighting control devices must be approved by the CEC (California Energy Commission).

B. Regulatory Requirements

1. Underwriters Laboratories: Provide U.L. listed lighting control equipment.
2. Code of Federal Regulations: 47 CFR - FCC All assemblies are to be in compliance with FCC emissions standards specified in Part 15 for Class A application.

1.7 WARRANTY

- A. Manufacturer's Warranty: The manufacturer shall provide a written warranty agreeing to provide parts to replace any portion of the lighting control system equipment that fails due to material or workmanship for a period of twelve months from warranty commencement.
- B. Warranty Commencement: Warranty shall begin at the point of substantial completion of the system installation, which is defined as the date when commissioning and owner training has been completed and the owner obtains beneficial use of the system.
- C. Warranty Replacement Parts: The manufacturer shall be able to ship replacement parts within 24 hours for any component that that fails due to material or workmanship during the warranty period.

PART 2 - PRODUCTS

2.1 TOGGLE SWITCHES

- A. Comply with NEMA WD 1, UL 20, and FS W-S-896.
- B. Switches, 120/277 V, 20 A:
 1. Products: Subject to compliance with requirements,
 - a. Single Pole:
 - 1) Cooper; AH1221.
 - 2) Hubbell; HBL1221.
 - 3) Leviton; 1221-2.
 - 4) Pass & Seymour; CSB20AC1.
 - b. Three Way:
 - 1) Cooper; AH1223.
 - 2) Hubbell; HBL1223.
 - 3) Leviton; 1223-2.
 - 4) Pass & Seymour; CSB20AC3.

**KOPACHUCK STATE PARK
DAY USE DEVELOPMENT**

2.2 WALL-BOX DIMMERS

- A. Subject to compliance with the contract documents, provide products from one of the following manufacturers:
 - 1. Lutron
 - 2. Leviton
 - 3. Wattstopper
- B. Dimmer Switches: Modular, full-wave, solid-state units with integral, quiet on-off switches, with audible frequency and EMI/RFI suppression filters.
- C. Control: Continuously adjustable with single-pole or three-way switching. Comply with UL 1472.
- D. Where two or more devices are ganged together, a single faceplate without visible fasteners will cover all devices.

2.3 INDOOR OCCUPANCY SENSORS

- A. Subject to compliance with the contract documents, provide products from one of the following manufacturers:
 - 1. Bryant Electric; a Hubbell company.
 - 2. Leviton Mfg. Company Inc.
 - 3. Lutron Electronics Co., Inc.
 - 4. Square D; a brand of Schneider Electric.
 - 5. Watt Stopper.
- B. General Operation
 - 1. The Occupancy Sensor system shall sense the presence of human activity within the desired space and fully control the on/off function of the loads automatically. Sensors shall turn on the load within 2 feet of entrance and shall not initiate "on" outside of entrance.
 - 2. Show the required sensor technologies on the plans or delete the following sentence.
 - 3. Sensing technologies shall be as indicated on the plans.
 - 4. Upon detection of human activity by the detector, a Time Delay shall be initiated to maintain the light on for a field adjustable pre-set period.
 - 5. Mounting
 - a. Sensor: Suitable for mounting in any position on a standard outlet box.
 - b. Relay (when required): Externally mounted through a 1/2 inch knockout in a standard electrical enclosure or integral to the sensor.
 - c. Time Delay and Sensitivity Adjustments: Recessed and concealed behind hinged door.
 - 6. Line Voltage Sensors

**KOPACHUCK STATE PARK
DAY USE DEVELOPMENT**

- a. Sensor shall be a self-contained dual voltage device capable of directly switching loads upon detection of human activity.
 - b. Sensor must be rated for 800 watts at 120 VAC, suitable for incandescent light fixtures, fluorescent light fixtures with electronic ballasts, or 1/6 hp motors or rated for 1000 watts at 277 VAC, suitable for LED light fixtures with electronic drivers, or 1/3 hp motors minimum. Sensor shall be capable of parallel wiring for 3-way switching applications.
 - c. Sensor Time Delay shall be factory set for typical applications, and field adjusted during commissioning. Sensor must provide a LED motion indicator.
7. Low Voltage Sensor
- a. Sensors must be designed to work in conjunction with remote power packs, relays, or other control systems. Sensors must operate with a Class 2, low voltage wiring strategy. Sensors must be capable of being parallel wired for multi-sensor applications.
 - b. Sensor must provide a transistor output, returning the voltage input rectified to DC, to control remote power packs, relays, or other control systems. Sensor must be available with an optional single pole, double throw signal relay capable of being wired open on occupancy, or closed on occupancy. Sensor Time Delay shall be factory set for typical applications, and field adjusted during commissioning. Sensor must provide a LED motion indicator.

C. Switch-Box Occupancy Sensors

- 1. General
 - a. Sensor must not protrude out from the cover plate more than 0.37 inches, and recess into the switch box more than 1 inch. Sensor must surface mount to single gang switch box and accept accessory plates for multi-gang installations. Sensor must provide an Off/Auto override switch, (2 switches if 2-pole device).
 - b. Optional 2-Pole units must be available. Manual or Auto ON shall be configurable for both poles.
- 2. Passive Infrared (PIR) Technology
 - a. PIR sensing, incorporating a combination of heat and movement sensing to detect occupancy in the area of coverage.
- 3. Dual Technology (DT)
 - a. Sensing must incorporate PIR with ultrasonic monitoring. Both PIR and Ultrasonic motion sensing shall initiate an ON condition and either technology sensing motion shall keep the ON state.
 - b. Either technology shall be able to be disabled during commissioning if necessary for the specific application.
- 4. Ultrasonic
 - a. Ultrasonic sensing incorporating an omni-directional Doppler technology to detect occupancy in the area of coverage.
- 5. Switch Type:
 - a. Single pole
 - b. Single pole, dual circuit.
 - c. Single pole, manual "on," automatic "off."
 - d. Single pole, field selectable automatic "on," or manual "on" automatic "off."
 - e. Single pole, dual circuit, manual "on", automatic "off".

**KOPACHUCK STATE PARK
DAY USE DEVELOPMENT**

- f. Single pole, dual circuit, field selectable automatic "on," or manual "on" automatic "off."

D. Ceiling Occupancy Sensors

1. General

- a. Sensor shall be ceiling mounted device, mounted to either a single gang enclosure, or surface mounted to a round surface raceway pancake box.
- b. Time delay shall be set during commissioning and field adjustable.
- c. Indicator: Digital display, to show when motion is detected during testing and normal operation of sensor.
- d. Bypass Switch: Override the "on" function in case of sensor failure.
- e. Ambient-Light Override: Where indicated on drawings provide concealed, field-adjustable, light-level sensor from 2 to 200 fc (21.5 to 2152 lux). The switch shall prevent the lights from turning on when the light level is higher than the set point of the sensor.
- f. Detector Sensitivity: Detect a person of average size and weight moving not less than 12 inches in either a horizontal or a vertical manner at an approximate speed of 12 inches/s.
- g. Detection Coverage
 - 1) Small Room: Detect occupancy anywhere within a circular area of 600 sq. ft. when mounted on a 96-inch-high ceiling.
 - 2) Standard Room: Detect occupancy anywhere within a circular area of 1000 sq. ft. when mounted on a 96-inch- high ceiling.
 - 3) Large Room: Detect occupancy anywhere within a circular area of 2000 sq. ft. when mounted on a 96-inch- high ceiling.
 - 4) Corridor: Detect occupancy anywhere within 90 feet when mounted on a 10-foot- high ceiling in a corridor not wider than 14 feet.

2. Passive Infrared (PIR) Technology

- a. PIR sensing, incorporating a combination of heat and movement sensing to detect occupancy in the area of coverage.
- b. PIR sensing must utilize a high-density Fresnel domed lens, providing a circular view pattern of 360 degrees.
- c. Sensitivity: Detect occurrences of 6-inch minimum movement of any portion of a human body that presents a target of at least 36 sq. in.

3. Dual Technology (DT)

- a. Sensing must incorporate PIR with Ultrasonic. Both PIR and Ultrasonic motion sensing shall initiate an ON condition and either technology sending motion shall keep the ON state.

E. Wall Mount Occupancy Sensors (low voltage)

1. General

- a. Sensor must be designed for large spaces where the occupants work area is up to 40 feet from the sensor. Sensor must be mounted 8 to 10 feet above the floor, out of occupants reach. Sensor shall be mounted either flat against the wall or in a corner. For pendant mount fixture applications, sensor must be mounted below the level of the fixture.

**KOPACHUCK STATE PARK
DAY USE DEVELOPMENT**

- b. Sensor time delay shall be set during commissioning and shall be capable of being field modified if necessary.
- c. Sensors must be capable of parallel wiring for multi-sensor applications.

2.4 POWER PACKS AND SLAVE PACKS

A. Manufacturer:

- 1. Bryant Electric; a Hubbell company.
- 2. Leviton Mfg. Company Inc.
- 3. Lithonia Lighting; Acuity Lighting Group, Inc.
- 4. Lutron Electronics Co., Inc.
- 5. Square D; a brand of Schneider Electric.
- 6. Watt Stopper.

B. Power Packs and Slave Packs must be designed to power and accept signals from remote Low Voltage Sensors, or other control devices, and directly switch the line voltage of the desired load controlled.

C. Power Packs must accept 120, 240, or 277 VAC utilizing a dual tap transformer.

D. Power Pack and Slave Pack relay switching shall not require more than 3 milliamps of current at 15 to 30 VDC.

E. Power Pack and Slave Pack relay switching shall be performed with a mechanical relay in parallel with an AC Semiconductor to allow relay contacts to switch under a no load condition. Switching capacity shall be 20 amps of all types of loads: Incandescent, Electronic Ballast, Magnetic, or Motor.

F. Power Packs shall be available in combination 2-Pole units capable of switching two independent loads, 20 amps each.

2.5 STAND ALONE ROOM AUTOMATIC CONTROLS

A. Manufacturers:

- 1. Subject to compliance with the contract documents, products of one of the following vendors are acceptable:
 - a. nLight by Sensor Switch, Acuity Brands Lighting, Inc.;
 - b. Wattstopper DLM
 - c. Lutron Energi Savr Node
 - d. Cooper Controls/Greengate Room Controller (for non-networked applications only)

B. Intelligent Room Controllers

- 1. Room Controllers must be designed to power and accept signals from remote low voltage sensors, or other control devices, and directly switch the line voltage of the desired load controlled.

**KOPACHUCK STATE PARK
DAY USE DEVELOPMENT**

2. Room Controllers must accept 120, 240, or 277 VAC utilizing a dual tap transformer.
3. Room Controllers shall allow power for auxiliary devices, depending on model.
4. Room Controller shall employ Zero Cross Circuitry for each load and shall be capable of switching a 20A load and dimming 0-10V loads. In addition, controllers shall be capable of dimming alternate methods, including but not limited to incandescent dimming, magnetic low voltage, forward phase electronic low voltage and LED drivers, and dimmable two-wire and three-wire fluorescent loads.
5. Room Controllers shall have 1, 2, or 3 switch legs, but no more than a 20A load per device.

C. Ceiling Mounted Occupancy Sensors

1. Ceiling mounted dual technology digital (passive infrared and ultrasonic or microphonic) occupancy sensor. Furnish the Company's system which accommodates the square-foot coverage requirements for each area controlled, utilizing room controllers, digital occupancy sensors and accessories which suit the lighting and electrical system parameters.

2.6 PHOTO SENSORS

- A. The photo sensor shall interface with multi-input digital addressable dimming ballasts. Dimming sensor shall connect directly to the ballast or module with 4 low voltage wires. Photo sensing element shall be a photoelectric sensor. Sensors shall be closed loop for single zone control or open loop for multi-zone control.

2.7 OUTDOOR PHOTOCELL SWITCHES

- A. Subject to compliance with the contract documents, provide products from one of the following manufacturers:

1. Intermatic, Inc.
2. Lithonia Lighting
3. Paragon Electric Co.
4. Square D
5. Tork
6. Wattstopper
7. Lutron

- B. Solid state with [SPST] dry contacts rated to operate connected relay, contactor coils, microprocessor input, and complying with UL 773A.

1. Light-Level Monitoring Range: 10 to 10,000 fc, with an adjustment for turn-on and turn-off levels within that range.
2. Time Delay: variable, to prevent false operation.
3. Surge Protection: Metal-oxide varistor type, complying with IEEE C62.41 for Category A1 locations.
4. Mounting: Twist lock complying with IEEE C136.10, with base-and-stem mounting or stem-and-swivel mounting accessories as required to direct sensor to the North sky exposure.

**KOPACHUCK STATE PARK
DAY USE DEVELOPMENT**

2.8 TIME SWITCHES (TIME CLOCKS)

- A. Subject to compliance with the contract documents, provide products from one of the following manufacturers:
 - 1. Intermatic, Inc.
 - 2. Leviton
 - 3. Lithonia Lighting
 - 4. Paragon Electric Co.
 - 5. Square D
 - 6. Tork
 - 7. Wattstopper

- B. Digital Time Switches: Electronic, solid-state programmable units with alphanumeric display complying with UL 917.
 - 1. Contact Configuration: DPDT
 - 2. Contact rating: 20A ballast load, 120/ 240 VAC
 - a. Program: Single channel, 2 on-off set points on a 24-hour schedule, allowing different set points for each day of the week and an annual holiday schedule that overrides the weekly operation on holidays.
 - b. Circuitry: Allow connection of a photoelectric relay to substitute for on and off function of a program.
 - c. Astronomical Time: All channels.
 - d. Battery Backup: For schedules and time clock.
 - 3. Digital Wall Box Time Switches: Electronic, solid-state programmable unit with numeric display.
 - a. Contact Configuration: SPST
 - b. Contact Rating: 0-800W ballasted 120-V ac, or 0-1200W ballasted 277-V ac.
 - c. Program: 8 on-off set points on a 24-hour schedule.

2.9 CONTROL RELAYS

- A. Industrial Control Relays: Rated 600V, 20A convertible contacts. Square D Class 8501 XMO series.
- B. General Purpose Relays: Rated 120/ 240 volt, 10A. Square D Class 8501 Type K plug in series with screw terminal socket

2.10 CONDUCTORS AND CABLES

- A. Power Wiring to Supply Side of Remote-Control Power Sources: Not smaller than No. 12 AWG, complying with Section 260519 - Low Voltage Electrical Power Conductors and Cables.

**KOPACHUCK STATE PARK
DAY USE DEVELOPMENT**

- B. Classes 2 and 3 Control Cable: Multiconductor cable with stranded copper conductors not smaller than No. 22 AWG, complying with Section 260519 - Low Voltage Electrical Power Conductors and Cables. Provide plenum rated as required.
- C. Class 1 Control Cable: Multiconductor cable with stranded copper conductors not smaller than No. 18 AWG, complying with Section 260519 - Low Voltage Electrical Power Conductors and Cables. Provide plenum rated as required.
- D. Install unshielded, twisted-pair cable for control and signal transmission conductors, complying with Section 260519 - Low Voltage Electrical Power Conductors and Cables. Provide plenum rated as required.

PART 3 - EXECUTION

3.1 SENSOR INSTALLATION

- A. Coordinate layout and installation of ceiling-mounted devices with other construction that penetrates ceilings or is supported by them, including light fixtures, HVAC equipment, smoke detectors, fire-suppression systems, and partition assemblies.
- B. Install and aim sensors in locations to achieve at least 90 percent coverage of areas indicated. Install sensors in accordance with manufacturer's instructions. Do not exceed coverage limits specified in manufacturer's written instructions.
- C. Where sensors are integral to light fixtures, coordinate orientation and location of fixture with sensor position.

3.2 DEVICE INSTALLATION

- A. Dimmers:
 - 1. Install dimmers within terms of their listing.
 - 2. Verify that dimmers used for fan speed control are listed for that application.
 - 3. Install unshared neutral conductors on line and load side of dimmers according to manufacturers' device listing conditions in the written instructions.
- B. Arrangement of Devices: Group adjacent switches under single, multigang wall plates.

3.3 WIRING INSTALLATION

- A. Wiring Method: Comply with Section 260519 - Low Voltage Electrical Power Conductors and Cables.
- B. Wiring within Enclosures: Comply with NECA 1. Separate power-limited and nonpower-limited conductors according to conductor manufacturer's written instructions.
- C. Size conductors according to lighting control device manufacturer's written instructions, unless otherwise indicated.

**KOPACHUCK STATE PARK
DAY USE DEVELOPMENT**

- D. Splices, Taps, and Terminations: Make connections only on numbered terminal strips in junction, pull, and outlet boxes; terminal cabinets; and equipment enclosures.

3.4 IDENTIFICATION

- A. Identify components and power and control wiring according to Section 260553 - Identification For Electrical Systems.
- B. Label time switches and contactors with a unique designation.

3.5 FIELD QUALITY CONTROL

- A. Perform the following field tests and inspections and prepare test reports:
 - 1. After installing time switches and sensors, and after electrical circuitry has been energized, adjust and test for compliance with manufacturers' commissioning checklist.
 - 2. Operational Test: Verify actuation of each sensor and adjust time delays.
- B. Remove and replace lighting control devices where test results indicate that they do not comply with specified requirements.
- C. Additional testing and inspecting, at Contractor's expense, will be performed to determine compliance of replaced or additional work with specified requirements.

3.6 SYSTEM STARTUP AND COMMISSIONING

- A. Commissioning shall take place prior to demonstration of system to Owner. After the system has been installed the Contractor shall provide manufacturer's recommended commissioning with factory trained and authorized technicians on-site, to:
 - 1. Verify that the contractor has properly installed and interconnected all necessary components.
 - 2. Verify correct operation of all system components.
 - 3. Verify that all switch and contact inputs are in compliance with contract requirements.
 - 4. Occupancy sensors and photo-sensors: Ensure that each sensor is correctly placed and oriented to provide the intended function. Adjust sensor location if unanticipated obstructions are present that impede the proper operation of the device.
 - 5. Submit completed verification checklist.

3.7 OWNER'S INSTRUCTIONS AND SYSTEM DEMONSTRATION

- A. System Demonstration
 - 1. Schedule demonstration a minimum of two-weeks prior to system turn over and substantial completion. Schedule with owner's representative and electrical engineer.
 - 2. Demonstrate complete system operation and contract compliance to designated owner's representative and engineer to prove system is functional and ready for comprehensive training.

**KOPACHUCK STATE PARK
DAY USE DEVELOPMENT**

B. System Instruction

1. The Contractor shall after one week (minimum) written notification to Architect conduct an instruction session during which all maintenance and operational aspects of the system will be described and demonstrated to personnel selected by the Owner. The session shall be conducted by a Contractor's representative thoroughly familiar with the characteristics of the system. O & M manual information regarding the system shall be turned over to the Architect prior to scheduling the instruction session.
2. Training shall utilize the following draft documents:
 - a. Draft O&M Manual
 - b. Contractor's record drawings
3. The training effort shall validate the O&M Manual and record drawing documentation.

END OF SECTION 260923

**KOPACHUCK STATE PARK
DAY USE DEVELOPMENT**

SECTION 262200 - LOW-VOLTAGE TRANSFORMERS

PART 1 - GENERAL

1.1 RELATED DOCUMENTS

- A. Drawings and general provisions of the Contract, including General Conditions and Division 01 Specification Sections, apply to this Section.

1.2 REFERENCES

- A. Transformers shall be manufactured, tested and installed in accordance with the latest revision of the following Standards and Publications.
 - 1. The Energy Policy and Conservation Act of 1975, Part C of Title III, Certain Industrial Equipment (Distribution Transformers), Department of Energy 10 CFR Part 431 Energy Conservation Program: Energy Conservation for Distribution Transformers, including amendments published in 78 FR 23335 (April 18, 2013) for implementation in 2016.
 - 2. American National Standards Institute (ANSI)
 - a. ANSI C57.12.91 IEEE Standard Test Code for Dry Type Distribution and Power Transformers.
 - 3. National Electrical Manufacturer's Association (NEMA)
 - a. NEMA ST-20 Dry-Type Transformers for General Applications
 - b. NEMA TP-1 Guide for Determining Energy Efficiency for Distribution Transformers
 - c. NEMA TR-1 Transformers, Regulators and Reactors R2000.
 - d. NEMA TP-3 Standard for the Labeling of Distribution Transformer Efficiency.
 - e. NEMA 250 Enclosures for Electrical Equipment 1,000 volts maximum.
 - 4. Underwriters Laboratories, Inc. (UL)
 - a. UL 506 Standard for Specialty Transformers (for transformers rated 10 kVA and below)
 - b. UL 1561 Standard for Dry Type General Purpose and Power Transformers (for transformers rated 10 to 1500 kVA)
 - 5. ASCE 7, Minimum Design Loads for Buildings and Other Structures (March 2013)

1.3 SUBMITTALS

- A. General: Conform to the contract document submittal requirements according to Section 260500 - Common Work Results For Electrical, and additional requirements described in this specification section.

**KOPACHUCK STATE PARK
DAY USE DEVELOPMENT**

B. Product Data:

1. Demonstrate conformance with specification requirements. Provide typical load losses for each transformer size at 0%, 40%, 75% and 100% of full load rating.
2. Submit lug schedule showing proposed lugs for each transformer.
3. Vibration Isolation

C. Shop Drawings: Detail equipment assemblies and indicate dimensions, weights, center of gravity, loads, required clearances, method of field assembly, components, and location and size of each field connection.

D. Seismic Data:

1. ASCE 7 Special Certificate: Submit manufacturer's Special Certification that transformers, overcurrent protective devices, accessories, and components will comply with the required seismic performance. Detailed description of equipment anchorage/isolation devices on which the certification is based and their installation requirements.
2. Provide additional data as required by designer of switchboard mounting structure.
3. Restraint method for vibration isolators.

E. Wiring Diagrams: Power wiring with polarity indication.

1.4 DELIVERY, STORAGE, AND HANDLING

- A. Temporary Heating: Apply temporary heat according to manufacturer's written instructions within the enclosure of each ventilated-type unit, throughout periods during which equipment is not energized and when transformer is not in a space that is continuously under normal control of temperature and humidity.

1.5 COORDINATION

- A. Coordinate size and location of concrete bases with actual transformer provided. Cast anchor-bolt inserts into bases. Concrete, reinforcement, and formwork requirements are specified in Division 03.
- B. Coordinate installation of wall-mounting and structure-hanging supports with actual transformer provided and seismic bracing requirements.

PART 2 - PRODUCTS

2.1 GENERAL

- A. Comply with the standards referenced in PART 1.

**KOPACHUCK STATE PARK
DAY USE DEVELOPMENT**

B. Seismic Criteria:

1. Provide Special Certification for Designated Seismic systems per ASCE/SEI 7 Chapter 13, *Seismic Design Requirements for Nonstructural Components*. Testing shall be in accordance with the following:
 - a. ICC ES 156 *Seismic Certification By Shake Table Testing of Non-Structural Components*.
 - b. Test shall utilize the following criteria from ASCE/SEI 7
 - 1) Importance factor, I_p , of 1.5.
 - 2) Height Factor (z/h) = 1.0, or as individually determined for each transformer from contract drawings.
 - 3) Ground acceleration, testing force, duration, frequency band with and related site factors shall meet or exceed the requirements determined by the most imposing values identified in ASCE/SEI 7.
 - c. A current listing on the State of California's OSHPD Special Seismic Certification Preapproval list with an S_{DS} value adequate for the site may be used to demonstrate compliance with these criteria.
2. Transformer shall remain in place without separation of any parts when subjected to seismic forces and the unit will be fully operational after the seismic event. Identify mounting and anchoring hardware compatible with the points of attachment to the transformer.

2.2 MANUFACTURERS

- A. Manufacturers: Subject to compliance with requirements, provide products by one of the following:
 1. ACME Electric Corporation; Power Distribution Products Division.
 2. Challenger Electrical Equipment Corp.; a division of Eaton Corp.
 3. Eaton Electrical Inc.; Cutler-Hammer Products.
 4. Federal Pacific Transformer Company; Division of Electro-Mechanical Corp.
 5. General Electric Company.
 6. Siemens Energy & Automation, Inc.
 7. Square D; Schneider Electric.
- B. Source Limitations: Obtain each transformer type through one source from a single manufacturer.

2.3 CONSTRUCTION

- A. Description: Factory-assembled and -tested, air-cooled units for 60-Hz service.
- B. Cores: Grain-oriented, non-aging silicon steel.
- C. Coils: Continuous windings without splices except for taps.

**KOPACHUCK STATE PARK
DAY USE DEVELOPMENT**

1. Internal Coil Connections: Brazed or pressure type.
2. Coil Material: Copper.

2.4 ENCLOSURE

- A. Steel panel enclosure over core, coil and terminal chamber with louvered openings for convection cooling. Cooling and terminal access shall be possible with both sides and rear of enclosure obstructed. Minimum 14 gage steel with appropriate reinforcement and lifting lugs
- B. Indoor: Ventilated, NEMA 250, Type 2.
- C. Outdoor: Ventilated with screened openings, raintight, NEMA 250 Type 3R
- D. Finish: Comply with NEMA 250 for ".Outdoor Corrosion Protection" Manufacturer's standard gray finish.

2.5 WINDINGS

- A. Separate primary and secondary. Windings shall have Class H insulation and shall be rated for continuous operation at rated kVA with temperature rise of not over 150 degrees C above a 40 degree C ambient, with a maximum hot spot temperature of 220 degrees C.
- B. Core and coil mounted on rubber isolation mounting pads. Windings and core and coil assembly shall be treated and built to resist the effects of dirt and moisture.
- C. Unless noted otherwise three phase transformers shall have a 480-volt delta connected primary and 208Y/120 volt, three phase, four wire secondary. Single phase transformers shall be 480-volt, single phase, primary, 120/240 volt, single phase, three wire secondary.
- D. Windings shall be copper or aluminum.
- E. Grounded electrostatic shield to reduce capacitive coupling where noted on the drawings. Include primary surge suppression and secondary filters similar to Square D Class 7450-FIL. Common mode noise attenuation: -65db, 1.5 to 100kHz.
- F. Encapsulate windings with resin compound to seal out moisture and air for transformers indicated on the drawings.

2.6 PRIMARY TAPS

- A. Transformers rated 15 KVA and larger shall have full capacity taps, minimum of two 2-1/2 percent above and four 2-1/2 percent below normal (rated) primary voltage.

2.7 RATINGS

- A. Continuous capacity rating not less than size noted.

**KOPACHUCK STATE PARK
DAY USE DEVELOPMENT**

B. Efficiency

1. Transformers shall comply with the Energy Policy Act of 1975 and subsequent amendments, and NEMA TP-1, applying whichever of the two standards has the greater efficiency for the specified kva size and phase.

2.8 CONNECTIONS

- A. Provisions for external connections shall be made by means of a terminal board employing lugs conforming to Section 260519 – Low Voltage Electrical Power Conductors and Cables which are compatible with the external conductors installed. All connections shall be accessible from front of cabinet.
- B. Wire termination provisions shall be based on and marked suitable for the use of 75C wire. The use of 90 C rated wire shall be acceptable, but not required.

2.9 NOISE LEVEL

- A. Manufacturer shall test for noise level compliance in accordance with ANSI C57.12.91, IEEE Standard Test Code for Dry Type Distribution and Power Transformers.
- B. Noise level shall not exceed 45 db for sizes less than 51 kVA, 50 db for 51-150 kVA, 55 db for 151-300 kVA and 60 db for sizes greater than 300 kVA.
- C. Quiet type reduced noise level transformers shall have noise levels not exceeding 42db for sizes less than 51 kVA, 47 db for 51-150 kVA and 52 db for 151 to 300 kVA and 57db for greater than 300 kVA.

PART 3 - EXECUTION

3.1 EXAMINATION

- A. Examine conditions for compliance with enclosure- and ambient-temperature requirements for each transformer.
- B. Verify that field measurements are as needed to maintain working clearances required by NFPA 70 and manufacturer's written instructions.
- C. Examine walls, floors, roofs, and concrete bases for suitable mounting conditions where transformers will be installed.
- D. Verify that ground connections are in place and requirements in Division 26 Section "Grounding and Bonding for Electrical Systems" have been met. Maximum ground resistance shall be 5 ohms at location of transformer.
- E. Proceed with installation only after unsatisfactory conditions have been corrected.

**KOPACHUCK STATE PARK
DAY USE DEVELOPMENT**

3.2 GENERAL

- A. Comply with manufacturer's requirements for storage, handling, and installation. Include copy of manufacturer's recommendation in Operations and Maintenance manual.
- B. Remove all shipping blocks prior to installation.

3.3 MOUNTING

A. General

- 1. All attachment nuts to have split and flat washer.
- 2. Mount on floor, wall or suspended from ceiling as indicated or as needed to coordinate with adjacent equipment. Set transformers level and plumb within 1/2 degree.
- 3. Compress pad or combination isolators to optimize vibration isolation at 60 Hz.

B. Floor mounting

- 1. Refer to Section 260500 - Common Work Results For Electrical for housekeeping pad requirements.
- 2. Secure floor mounted types to floor via rubber pad isolators.
- 3. Mount transformer on combination isolator.

C. Wall Mounting

- 1. On concrete and block walls, secure wall mounted types, or floor mounted types with wall brackets and appropriate anchors. For gypsum wall construction provide independent steel channel supports, secured to floor.
- 2. Size brackets and anchors to give 400% safety factor. Submit shop drawing of manufacturer's standard bracket or proposed channel assembly.
- 3. Isolate transformer via pad isolation between wall bracket and transformer.
- 4. Mount transformer on combination isolator. Provide additional hardware to interface between isolator and mounting bracket.

3.4 CONNECTIONS

- A. Provide raceway rough-in to allow for cable pulling and minimum cable bending requirements.
- B. 208/120-volt three phase and 120/240-volt single phase secondary transformers shall be considered "grounded neutral separately derived systems" and neutral shall be grounded per code.
- C. Transformer raceway connections shall be flexible metal conduit as specified in Section 260533 - Raceways and Boxes for Electrical Systems.
- D. Voltage Tap Connections: Connect all transformers at "normal" tap. After facility is completely energized, measure secondary voltages and phase current at all transformers and service switchboard. Forward a list to Engineer and Architect for evaluation. Include copy in O&M

**KOPACHUCK STATE PARK
DAY USE DEVELOPMENT**

Manual. Reconnect taps as subsequently directed. All costs associated with this work to be included in base bid.

- E. Insulation temperature rating of conductors connecting to transformers shall be 90C or higher.

3.5 IDENTIFICATION

- A. Provide permanently attached engraved nameplates per Section 260553 - Identification For Electrical Systems for each transformer.

3.6 ADJUSTING

- A. Output Settings Report: Prepare a written report recording output voltages and tap settings.

END OF SECTION 262200

**KOPACHUCK STATE PARK
DAY USE DEVELOPMENT**

SECTION 262416 - PANELBOARDS

PART 1 - GENERAL

1.1 RELATED DOCUMENTS

- A. Drawings and general provisions of the Contract, including General Conditions, Division 1 Specification Sections, and Section 260500 Common Work Results for Electrical, apply to this Section.

1.2 SUBMITTALS

- A. Product Data: For each type of panelboard, switching and overcurrent protective device, transient voltage suppression device, accessory, and component indicated. Include dimensions and manufacturers' technical data on features, performance, electrical characteristics, ratings, and finishes.
- B. Shop Drawings: For each panelboard and related equipment.
1. Include dimensioned plans, elevations, sections, and details. Show tabulations of installed devices, equipment features, and ratings.
 - a. Verify space available with equipment sizes and code required working clearances prior to submitting shop drawings.
 2. Detail enclosure types and details for types other than NEMA 250, Type 1.
 3. Detail bus configuration, current, and voltage ratings.
 4. Short-circuit current rating of panelboards and overcurrent protective devices.
 5. Contractor provided overcurrent protective device study".
 6. Include evidence of NRTL listing for series rating of installed devices.
 7. Detail features, characteristics, ratings, and factory settings of individual overcurrent protective devices and auxiliary components.
Include time-current coordination curves for each type and rating of overcurrent protective device included in panelboards. Submit on translucent log-log graft paper; include selectable ranges for each type of overcurrent protective device.
- C. Seismic Data:
1. ASCE7 Special Certificate: Submit manufacturer's Special Certification that panelboards, overcurrent protective devices, accessories, and components will comply with the required seismic performance. Detailed description of equipment supports and anchorage devices on which the certification is based and their installation requirements.
 2. Dimensioned Outline Drawings of Equipment Unit: Identify center of gravity and locate and describe mounting and anchorage provisions.
 3. Provide additional data as required by designer of panelboard mounting structure.

**KOPACHUCK STATE PARK
DAY USE DEVELOPMENT**

- D. Panelboard Schedules: For installation in panelboards.
- E. Operation and Maintenance Data: For panelboards and components to include in emergency, operation, and maintenance manuals. In addition to items specified in Division 01 Section "Operation and Maintenance Data," include the following:
 - 1. Manufacturer's written instructions for testing and adjusting overcurrent protective devices.
 - 2. Time-current curves, including selectable ranges for each type of overcurrent protective device that allows adjustments.

1.3 COORDINATION

- A. Coordinate layout and installation of panelboards and components with other construction that penetrates walls or is supported by them, including electrical and other types of equipment, raceways, piping, encumbrances to workspace clearance requirements, and adjacent surfaces. Maintain required workspace clearances and required clearances for equipment access doors and panels.
- B. Coordinate sizes and locations of concrete bases with actual equipment provided. Cast anchor-bolt inserts into bases. Concrete, reinforcement, and formwork requirements are specified in Division 03.

1.4 EXTRA MATERIALS

- A. Furnish extra materials that match products installed and that are packaged with protective covering for storage and identified with labels describing contents.
 - 1. Keys: Two spares for each type of panelboard cabinet lock.
 - 2. Directories: 10% of project directories provided as blanks

PART 2 - PRODUCTS

2.1 GENERAL

- A. Comply with:
 - 1. NEMA PB2.
 - 2. UL 67.
 - 3. UL 50 for cabinets boxes and trims.
 - 4. NFPA 70.
 - 5. Electrical Components, Devices, and Accessories: Listed and labeled as defined in NFPA 70, by a qualified testing agency, and marked for intended location and application.
 - 6. Labels as required by UL and NFPA 70, as adopted and amended by local codes.
- B. Seismic Criteria:

**KOPACHUCK STATE PARK
DAY USE DEVELOPMENT**

1. Provide Special Certification for Designated Seismic systems per ASCE/SEI 7 Chapter 13, *Seismic Design Requirements for Nonstructural Components*. Testing shall be in accordance with the following:
 - a. ICC ES 156 *Seismic Certification By Shake Table Testing of Non-Structural Components*.
 - b. Test shall utilize the following criteria from ASCE/SEI 7
 - 1) Importance factor, I_p , of 1.5.
 - 2) Height Factor (z/h) = 1.0, or as individually determined for each switchboard from contract drawings.
 - 3) Ground acceleration, testing force, duration, frequency bandwidth and related site factors shall meet or exceed the requirements determined by the performance criteria defined in Section 260548 "Seismic Controls for Electrical Systems". Where information is unavailable (ie a_p) use the most imposing values identified in ASCE/SEI 7.
 - c. A current listing on the State of California's OSHPD Special Seismic Certification Preapproval list with an S_{DS} value adequate for the site may be used to demonstrate compliance with these criteria.
2. Panelboard shall remain in place without separation of any parts when subjected to seismic forces and the unit will be fully operational after the seismic event. Identify mounting and anchoring hardware compatible with the points of attachment to the Panelboard.

2.2 MANUFACTURER

- A. Manufacturers: Subject to compliance with requirements, provide products or comparable product by one of the following:
 1. Eaton Electrical Inc
 2. General Electric Company
 3. Siemens Energy & Automation, Inc.
 4. Schneider Electric.
 5. IEM.

2.3 ENCLOSURES

- A. Flush or surface-mounted cabinets, as indicated on drawings or panel schedules.
- B. Rated for environmental conditions at installed location.
 1. Indoor Dry and Clean Locations: NEMA 250, Type 1.
 2. Outdoor Locations: NEMA 250, Type 3R.
 3. Kitchen and Wash-Down Areas: NEMA 250, Type 4X, stainless steel.
 4. Indoor Locations Subject to Dust, Falling Dirt, and Dripping Noncorrosive Liquids: NEMA 250 Type 12.

**KOPACHUCK STATE PARK
DAY USE DEVELOPMENT**

- C. Hinged Front Cover: Entire front trim hinged to box and with standard door within hinged trim cover (door in door). Key identically.
- D. Where two cabinets are located adjacent to each other in finished areas, provide matching trim.
- E. Where remote controlled switch or contactor is mounted in panelboard, mount on same frame as panelboard interior, with dedicated access door and key lock.
- F. Finishes:
 - 1. Panels and Trim: Steel, factory finished immediately after cleaning and pretreating with manufacturer's standard two-coat, baked-on finish consisting of prime coat and thermosetting topcoat.
 - 2. Back Boxes: Steel, galvanized where construction sequencing exposes the back box to water, otherwise same finish as panels and trim.
- G. Directory Card: Inside panelboard door, mounted in metal frame with transparent protective cover, type written. Handwritten is not acceptable.

2.4 BUSSING AND WIRING

- A. Incoming Mains Location: Top or bottom, as determined by contractor in conjunction with information presented on the drawings.
- B. Phase, Neutral, and Ground Buses:
 - 1. In subparagraph below, aluminum is standard with most manufacturers; copper usually costs more, edit if client does not want aluminum.
 - 2. Material: Tin-plated aluminum or Hard-drawn copper, 98 percent conductivity.
 - 3. Panelboards shall have full ampacity bussing throughout and shall be full size in regard to number of possible pole spaces. Bussing shall be identified with phases reading left to right.
 - 4. Neutral bus shall be mounted independently of equipment ground bus.
 - 5. Equipment Ground Bus: Adequate for feeder and branch-circuit equipment grounding conductors; bonded to box and located on back of panelboard. Shall have lug or lugs from equipment grounding conductor from switchboard or distribution board and screw type terminals for connection of equipment green ground wire in same quantity as number of poles in panel.
- C. Features as scheduled:
 - 1. Isolated Ground Bus: Adequate for branch-circuit isolated ground conductors; insulated from box.
 - 2. Extra-Capacity Neutral Bus: Neutral bus rated 200 percent of phase bus and UL listed as suitable for nonlinear loads. Conductor connectors to match oversizing.
 - 3. Split Bus: Vertical buses divided into individual vertical sections.
- D. Conductor Connectors: Suitable for use with conductor material and sizes.

**KOPACHUCK STATE PARK
DAY USE DEVELOPMENT**

1. Material: Tin-plated aluminum or Hard-drawn copper, 98 percent conductivity.
2. Method: Mechanical Screw type.
3. Features as scheduled:
 - a. Feed-Through Lugs. Locate at opposite end of bus from incoming lugs or main device.
 - b. Subfeed (Double) Lugs: Locate at same end of bus as incoming lugs or main device.
 - c. Gutter-Tap Lugs: Locate at same end of bus as incoming lugs or main device.
- E. Future Devices: Mounting brackets, bus connections, filler plates, and necessary appurtenances required for future installation of devices.
- F. Panelboards rated for 400 amps and above shall accept 225 amp frame circuit breakers.
- G. Panelboard Short-Circuit Current Rating: Refer to Panel Schedules and one line diagrams.
 1. Fully rated to interrupt symmetrical short-circuit current available at terminals.
 2. Minimum interrupting ratings shall be 14,000 (RMS Symmetrical) at 480/277V and 10,000 (RMS Symmetrical) at 208/120V.

2.5 OVERCURRENT PROTECTIVE DEVICES

- A. Overcurrent Protective Devices shall be the same manufacturer as panelboard.
- B. Fully rated for the available short circuit current.
- C. Series Short-Circuit Current Ratings: Rated for series-connected system with integral or remote upstream overcurrent protective devices and labeled by an NRTL. Include size and type of allowable upstream and branch devices, listed and labeled for series-connected short-circuit rating by an NRTL.
- D. Molded-Case Circuit Breaker (MCCB): Comply with UL 489. Standard frame sizes, trip ratings, and number of poles. Mechanical lugs, able to terminate conductors indicated on drawings.
 1. Frame size 100A: Thermal-Magnetic sensing with inverse time-current element for low-level overloads and instantaneous magnetic trip element for short circuits.
 2. Frame sizes over 250A and up to 800A: Thermal-Magnetic sensing with inverse time-current element for low-level overloads and adjustable instantaneous magnetic trip element for short circuits. Adjustable instantaneous trip element shall have front-mounted dial or utilize electronic trip unit.
 3. Frame sizes 800 amps and over: Electronic trip-units with RMS sensing, field-replaceable rating plug, and the following discrete (field-adjustable) sensing::
 - a. Instantaneous trip.
 - b. Long- and short-time pickup levels.
 - c. Long- and short-time time delay adjustments.
 4. Trip ratings 1000A and above:

**KOPACHUCK STATE PARK
DAY USE DEVELOPMENT**

- a. As required for frame sizes 800 amps and over.
 - b. Ground-fault pickup level and time delay. Omit ground fault sensing for circuits serving loads addressed by NEC Articles 700 and 701.
- E. Circuit-Breaker Features and Accessories: Provide the following construction and ratings where indicated on the drawings:
1. Current-Limiting: Under short circuit conditions, circuit breaker shall interrupt current in less than ¼ cycle to reduce let through current. Frame sizes 400 A and smaller shall have let-through ratings less than NEMA FU 1, RK-5.
 2. Branch Circuits:
 - a. GFCI Circuit Breakers: Ground Fault Circuit Interrupter, single- and two-pole configurations with Class A ground-fault protection (6-mA trip). Push to test and ground fault indicator.
 - b. Ground-Fault Equipment Protection (GFEP) Circuit Breakers: Class B ground-fault protection (30-mA trip).
 - c. Arc-Fault Circuit Interrupter (AFCI) Circuit Breakers: Comply with UL 1699; 120/240-V, single-pole configuration.
 - d. Combination AFCI/GFCI: As above for individual ratings.
 3. Shunt Trip: 120-V trip coil energized from separate circuit, set to trip at 55 percent of rated voltage.
 4. Undervoltage Trip: Set to operate at 35 to 75 percent of rated voltage with field-adjustable 0.1- to 0.6-second time delay.
 5. Auxiliary Contact: SPDT switch with "a" and "b" contacts; "a" contacts mimic circuit-breaker contacts and "b" contacts operate in reverse of circuit-breaker contacts.
 6. Alarm Switch: Single-pole, normally open contact that actuates only when circuit breaker trips.
 7. Key Interlock Kit: Externally mounted to prohibit circuit-breaker operation; key shall be removable only when circuit breaker is in off position.
 8. Zone-Selective Interlocking: Integral with electronic trip unit; for interlocking ground-fault protection function with other upstream or downstream devices.
 9. Handle Padlocking Device: Fixed attachment, for locking circuit breaker handle in on or off position.
- F. Applications:
1. Circuit breakers shall have listing appropriate for the application.
 2. Lighting Loads: Type SWD for switching fluorescent loads; Type HID for feeding fluorescent and high-intensity discharge (HID) lighting circuits.
 3. Fire Alarm circuits: Handle clamp for holding circuit-breaker handle in on position to avoid accidental switching.
- G. Where spare is indicated, panelboard shall be provided with the specified branch circuit breaker, full ampacity bussing and mounting hardware. Where space is indicated, panelboard shall be provided with full ampacity bussing and mounting hardware to accommodate future installation of branch circuit breaker. Provide individual filler/cover plates for each breaker space.

**KOPACHUCK STATE PARK
DAY USE DEVELOPMENT**

2.6 NAMEPLATES

- A. Engraved nameplates per Section 260553 - Identification for Electrical Systems permanently attached to panelboard front. Include panel name with 1/4" letters, area served, voltage, phase and wire (e.g., 2N1, 208Y/120, 3 phase, 4 wire, 480Y/277, 3 phase, 4 wire) in 1/8 inch characters. When project has more than one switchboard include switchboard fed from (e.g., Fed from SWBD. 4BP).
- B. Nameplate color: Normal system - white letters on black.

PART 3 - EXECUTION

3.1 EXAMINATION

- A. Receive, inspect, handle, and store panelboards according to NECA 407 and NEMA PB 1.1.
- B. Examine panelboards before installation. Reject panelboards that are damaged or rusted or have been subjected to water saturation.
- C. Examine elements and surfaces to receive panelboards for compliance with installation tolerances and other conditions affecting performance of the Work.
- D. Proceed with installation only after unsatisfactory conditions have been corrected.

3.2 INSTALLATION

- A. Install panelboards and accessories according to NECA 407 and NEMA PB 1.1.
 - 1. Secure flush mounted panels to studs in wall via slotted channel or angle iron.
 - 2. Provide additional reinforcement where wall construction is inadequate for size and weight of panelboard.
 - 3. Place and secure anchorage devices in masonry and concrete elements. Use setting drawings, templates, diagrams, instructions, and directions furnished with items to be embedded.
- B. Temporary Lifting Provisions: Remove temporary lifting eyes, channels, and brackets and temporary blocking of moving parts from panelboards.
- C. Mount top of panel trim according to the following priorities (highest listed first):
 - 1. At the height determined by the panelboard when panelboard size and weight require floor mounting.
 - 2. In compliance with the operating handle height limitation of the NEC.
 - 3. At the height indicated on the drawings.
 - 4. As necessary to permit adjacent panels in finished areas to have trim heights aligned.
 - 5. At 90 inches for panel cabinets above 42 inches in height, and at 78 inches for panel cabinets equal to or less than 42 inches in height.

**KOPACHUCK STATE PARK
DAY USE DEVELOPMENT**

- D. Mount panelboard cabinet plumb and rigid without distortion of box. Mount recessed panelboards with fronts uniformly flush with wall finish and mating with back box.
- E. Panelboards installed recessed in fire rated walls shall be adequately boxed or backed with fire rated material and shall be approved by Fire Marshal. The final construction shall equal or exceed fire rating of the wall.
- F. Locate in dedicated spaces. Coordinate project construction so piping, ducts, etc. are routed around dedicated spaces above and in front of panelboards per code.
- G. Verify space available with equipment sizes and code required working clearances prior to roughing in of back box or cabinet.
- H. Install overcurrent protective devices and controllers not already factory installed.
 - 1. Set field-adjustable, circuit-breaker trip ranges.
- I. Install filler plates in unused spaces.
- J. Arrange conductors in gutters into groups and bundle and wrap with wire ties, after completing load balancing.

3.3 WIRING

- A. Conform to applicable sections of these specifications and NEMA PB 1.1.
- B. Panelboards shall be wired and connected after installation at locations shown. Pre-wiring off site and splicing of branch circuit in wireway above or below panelboard is not permitted.

3.4 CIRCUIT INDEX AND LABELS

- A. Typed circuit index with odd circuits on left, even circuits on right, listing each circuit by number with complete load designation, (i.e. Receptacle room, lights room, etc.). Room names/numbers per actual room identification assigned by owner at project completion (assigned room numbers may differ from drawings). Mount inside door with transparent protective cover. Provide number labels on circuit breakers to match index.
- B. Install nameplate as per Part 2.

3.5 GROUNDING

- A. Provide per Section 260526 - Grounding and Bonding for Electrical Systems.

3.6 FIELD QUALITY CONTROL

- A. Manufacturer's Field Service: Engage a factory-authorized service representative to inspect, test, and adjust components, assemblies, and equipment installations, including connections.

**KOPACHUCK STATE PARK
DAY USE DEVELOPMENT**

- B. Acceptance Testing Preparation:
 - 1. Test insulation resistance for each panelboard bus, component, connecting supply, feeder, and control circuit.
 - 2. Test continuity of each circuit.

- C. Tests and Inspections:
 - 1. Perform each visual and mechanical inspection and electrical test stated in NETA Acceptance Testing Specification. Certify compliance with test parameters.
 - 2. Correct malfunctioning units on-site, where possible, and retest to demonstrate compliance; otherwise, replace with new units and retest.

- D. Panelboards will be considered defective if they do not pass tests and inspections.

- E. Prepare test and inspection reports, including a certified report that identifies panelboards included and that describes scanning results. Include notation of deficiencies detected, remedial action taken, and observations after remedial action.

3.7 ADJUSTING

- A. Adjust moving parts and operable component to function smoothly and lubricate as recommended by manufacturer.

- B. Set field-adjustable circuit-breaker trip ranges as directed and in accordance with Contractor Provided "Overcurrent Protective Device Coordination Study."

- C. Load Balancing: After Substantial Completion, but not more than 60 days after Final Acceptance, measure load balancing and make circuit changes.
 - 1. Measure as directed during period of normal system loading.
 - 2. Perform load-balancing circuit changes outside normal occupancy/working schedule of the facility and at time directed. Avoid disrupting critical 24-hour services such as fax machines and on-line data processing, computing, transmitting, and receiving equipment.
 - 3. After circuit changes, recheck loads during normal load period. Record all load readings before and after changes and submit test records.
 - 4. Tolerance: Difference exceeding 20 percent between phase loads, within a panelboard, is not acceptable. Rebalance and recheck as necessary to meet this minimum requirement.

**KOPACHUCK STATE PARK
DAY USE DEVELOPMENT**

3.8 CLEANING

- A. Prior to final inspection, clean panelboard interiors, adjust trims, covers, hinges and locks and refinish marred or scratched covers to original conditions. Remove paint splatters and other spots. Vacuum dirt and debris; do not use compressed air to assist in cleaning. Repair exposed surfaces to match original finish.

3.9 PROTECTION

- A. Temporary Heating: Apply temporary heat to maintain temperature according to manufacturer's written instructions.

END OF SECTION 262416

**KOPACHUCK STATE PARK
DAY USE DEVELOPMENT**

SECTION 262816 - ENCLOSED SWITCHES AND CIRCUIT BREAKERS

PART 1 - GENERAL

1.1 RELATED DOCUMENTS

- A. Drawings and general provisions of the Contract, including General and Supplementary Conditions and other Division 01 Specification Sections, apply to this Section.

1.2 SUMMARY

A. Section Includes:

1. Fusible switches.
2. Nonfusible switches.
3. Receptacle switches.
4. Shunt trip switches.
5. Molded-case circuit breakers (MCCBs).
6. Molded-case switches.
7. Enclosures.

- B. Provide all disconnects required by code for equipment furnished under this and other Divisions of these specifications unless disconnects are integral with equipment and acceptable to the authority having jurisdiction.

1.3 REFERENCES

- A. National Electrical Manufacturers Association (NEMA)
- B. Underwriters Laboratories (UL)

1.4 DEFINITIONS

- A. NC: Normally closed.
- B. NO: Normally open.
- C. SPDT: Single pole, double throw.

1.5 PERFORMANCE REQUIREMENTS

- A. Seismic Performance: Enclosed switches and circuit breakers shall withstand the effects of earthquake motions determined according to ASCE/SEI 7.

**KOPACHUCK STATE PARK
DAY USE DEVELOPMENT**

1. The term "withstand" means "the unit will remain in place without separation of any parts from the device when subjected to the seismic forces specified.

1.6 ACTION SUBMITTALS

- A. Product Data: For each type of enclosed switch, circuit breaker, accessory, and component indicated. Include dimensioned elevations, sections, weights, and manufacturers' technical data on features, performance, electrical characteristics, ratings, accessories, and finishes.
 1. Enclosure types and details for types other than NEMA 250, Type 1.
 2. Current and voltage ratings.
 3. Short-circuit current ratings (interrupting and withstand, as appropriate).
 4. Include evidence of NRTL listing for series rating of installed devices.
 5. Detail features, characteristics, ratings, and factory settings of individual overcurrent protective devices, accessories, and auxiliary components.
 6. Include time-current coordination curves (average melt) for each type and rating of overcurrent protective device; include selectable ranges for each type of overcurrent protective device.
- B. Shop Drawings: For enclosed switches and circuit breakers. Include plans, elevations, sections, details, and attachments to other work.
 1. Wiring Diagrams: For power, signal, and control wiring.

1.7 INFORMATIONAL SUBMITTALS

- A. Qualification Data: For qualified testing agency.
- B. Seismic Qualification Certificates: For enclosed switches and circuit breakers, accessories, and components, from manufacturer.
 1. Basis for Certification: Indicate whether withstand certification is based on actual test of assembled components or on calculation.
 2. Dimensioned Outline Drawings of Equipment Unit: Identify center of gravity and locate and describe mounting and anchorage provisions.
 3. Detailed description of equipment anchorage devices on which the certification is based and their installation requirements.
- C. Field quality-control reports.
 1. Test procedures used.
 2. Test results that comply with requirements.
 3. Results of failed tests and corrective action taken to achieve test results that comply with requirements.
- D. Manufacturer's field service report.

**KOPACHUCK STATE PARK
DAY USE DEVELOPMENT**

1.8 CLOSEOUT SUBMITTALS

- A. Operation and Maintenance Data: For enclosed switches and circuit breakers to include in emergency, operation, and maintenance manuals. In addition to items specified Section 017700 – Closeout Procedures, “Operation and Maintenance (O&M) Instruction Manual” include the following:
 - 1. Manufacturer's written instructions for testing and adjusting enclosed switches and circuit breakers.
 - 2. Time-current coordination curves (average melt) for each type and rating of overcurrent protective device; include selectable ranges for each type of overcurrent protective device.

1.9 QUALITY ASSURANCE

- A. Source Limitations: Obtain enclosed switches and circuit breakers, overcurrent protective devices, components, and accessories, within same product category, from single source from single manufacturer.
- B. Product Selection for Restricted Space: Drawings indicate maximum dimensions for enclosed switches and circuit breakers, including clearances between enclosures, and adjacent surfaces and other items. Comply with indicated maximum dimensions.
- C. Electrical Components, Devices, and Accessories: Listed and labeled as defined in NFPA 70, by a qualified testing agency, and marked for intended location and application.
- D. Comply with NFPA 70.

1.10 PROJECT CONDITIONS

- A. Environmental Limitations: Rate equipment for continuous operation under the following conditions unless otherwise indicated:
 - 1. Ambient Temperature: Not less than minus 22 deg F (minus 30 deg C) and not exceeding 104 deg F (40 deg C).
 - 2. Altitude: Not exceeding 6600 feet (2010 m).

1.11 COORDINATION

- A. Coordinate layout and installation of switches, circuit breakers, and components with equipment served and adjacent surfaces. Maintain required workspace clearances and required clearances for equipment access doors and panels.

**KOPACHUCK STATE PARK
DAY USE DEVELOPMENT**

PART 2 - PRODUCTS

2.1 MANUFACTURERS

- A. Manufacturers: Subject to compliance with requirements, provide products by one of the following:
 - 1. Eaton Electrical Inc
 - 2. General Electric Company.
 - 3. Siemens Energy & Automation, Inc.
 - 4. Schneider Electric.

2.2 RATINGS

- A. Voltage: Meet or exceed voltage of the circuit the switch or circuit breaker is applied to.
- B. Current
 - 1. Continuous current rating shall be either of the following:
 - a. As indicated on the drawings.
 - b. If not indicated, match or exceed the continuous current rating of the overcurrent protective device that protects the conductor providing incoming power to the switch or circuit breaker.
 - 2. Short circuit withstand and interrupting ratings
 - a. Shall comply with either of the following:
 - 1) If the available short circuit current at the switch or circuit breaker is indicated on the drawings, exceed the indicated value while allowing for appropriate X/R derating.
 - 2) Meet or exceed the AIC rating of the overcurrent protective device that protects the conductor providing incoming power to the switch or circuit breaker.
 - b. Compliance: Short circuit withstand, and interrupting ratings shall be complied with using any of the following methods:
 - 1) Listed short circuit ratings complying with above criteria.
 - 2) Independent testing laboratory recognized series connected ratings complying with the above criteria.
 - 3) Oversizing the indicated switch or circuit breaker rated current to obtain a listed short circuit withstand and interrupting rating complying with the above criteria, if the appropriate amount of space is available at the indicated location.
 - 4) If a non-fusible disconnect is indicated, it may be changed to a fusible disconnect to obtain the required listed short circuit current withstand rating.

**KOPACHUCK STATE PARK
DAY USE DEVELOPMENT**

3. Overcurrent Protection

- a. Provide overcurrent protection matching the ampacity indicated on the drawings.
- b. When included as part of the disconnecting means for utilization equipment the overcurrent protection shall comply with the listing requirements of the utilization equipment. Obtain utilization equipment shop drawings as specified in the appropriate specification division to determine requirements.

C. Poles: Match the circuit the switch or circuit breaker is applied to.

2.3 FUSIBLE SWITCHES

- A. Type GD, General Duty, Single Throw, 100 A and Smaller: UL 98 and NEMA KS 1, horsepower rated, with cartridge fuse interiors, lockable handle with capability to accept two padlocks, and interlocked with cover in closed position.
- B. Type HD, Heavy Duty, Single Throw, Larger than 100 amp: UL 98 and NEMA KS 1, horsepower rated, with clips or bolt pads to accommodate fuses, lockable handle with capability to accept three padlocks, and interlocked with cover in closed position.
- C. Accessories:
 - 1. Class R Fuse Kit: Provides rejection of other fuse types when Class R fuses are specified.

2.4 NONFUSIBLE SWITCHES

- A. Type GD, General Duty, Single Throw, 100 A and Smaller: UL 98 and NEMA KS 1, horsepower rated, lockable handle with capability to accept two padlocks, and interlocked with cover in closed position.
- B. Type HD, Heavy Duty, Single Throw, Larger than 100 amp. UL 98 and NEMA KS 1, horsepower rated, lockable handle with capability to accept three padlocks, and interlocked with cover in closed position.
- C. Type HD, Heavy Duty, Double Throw, 1200 A and Smaller: UL 98 and NEMA KS 1, horsepower rated, lockable handle with capability to accept three padlocks, and interlocked with cover in closed position.

2.5 MOLDED-CASE CIRCUIT BREAKERS

- A. General Requirements: Comply with UL 489, NEMA AB 1, and NEMA AB 3, with interrupting capacity to comply with available fault currents.
- B. Thermal-Magnetic Circuit Breakers: Inverse time-current element for low-level overloads and instantaneous magnetic trip element for short circuits. Adjustable magnetic trip setting for circuit-breaker frame sizes 250 A and larger.

KOPACHUCK STATE PARK DAY USE DEVELOPMENT

- C. Molded Case Switch: When serving only as a disconnecting means.
- D. Frame sizes 400 amp and larger: Electronic Trip Circuit Breakers: rms sensing, with the following field-adjustable settings:
 - 1. Instantaneous trip.
 - 2. Long- and short-time pickup levels.
 - 3. Long- and short-time time adjustments.
- E. Current-Limiting Circuit Breakers: Frame sizes 400 A and smaller, and let-through ratings less than NEMA FU 1, RK-5.

2.6 ACCESSORIES

- A. Lugs: Mechanical type, suitable for number, size, trip ratings, and conductor material.
- B. Equipment Ground Kit: Internally mounted and labeled for copper and aluminum ground conductors.
- C. Neutral Kit: Required where neutral conductor is indicated on the drawings. Internally mounted; insulated, capable of being grounded and bonded; labeled for copper and aluminum neutral conductors.
- D. Additional accessories, where indicated.
 - 1. Ground-Fault Protection: Comply with UL 1053; remote-mounted and powered type with mechanical ground-fault indicator; relay with adjustable pickup and time-delay settings, push-to-test feature, internal memory, and shunt trip unit; and three-phase, zero-sequence current transformer/sensor.
 - 2. Shunt Trip: Trip coil energized from separate circuit, with coil-clearing contact.
 - 3. Auxiliary Contacts: One SPDT switch with "a" and "b" contacts; "a" contacts mimic switch contacts, "b" contacts operate in reverse of switch contacts.
 - 4. Alarm Switch: One SPDT contact that operates only when switch has tripped.

2.7 ENCLOSURES

- A. Enclosed Switches and Circuit Breakers: NEMA AB 1, NEMA KS 1, NEMA 250, and UL 50, to comply with environmental conditions at installed location.
 - 1. Indoor, Dry and Clean Locations: NEMA 250, Type 1.
 - 2. Outdoor Locations: NEMA 250, Type 3R.
 - 3. Kitchen, Wash-Down Areas: NEMA 250, Type 4X, stainless steel.
 - 4. Other Wet or Damp, Indoor Locations: NEMA 250, Type 4.
 - 5. Indoor Locations Subject to Dust, Falling Dirt, and Dripping Noncorrosive Liquids: NEMA 250, Type 12.

**KOPACHUCK STATE PARK
DAY USE DEVELOPMENT**

2.8 NAMEPLATES

- A. Provide nameplates per Section 260553 - Identification For Electrical Systems.
- B. Provide permanently attached nameplates (with mechanical fasteners) constructed of plastic (black on white) laminated material engraved through black surface material to white sublayer. Exception: Emergency distribution system component labeling - white letters on red background.
- C. Include the following information: Load name, voltage and phase and fuse size and type (when applicable).

PART 3 - EXECUTION

3.1 EXAMINATION

- A. Examine elements and surfaces to receive enclosed switches and circuit breakers for compliance with installation tolerances and other conditions affecting performance of the Work.
- B. Proceed with installation only after unsatisfactory conditions have been corrected.

3.2 INSTALLATION

- A. Install individual wall-mounted switches and circuit breakers level and plumb according to manufacturer's written instructions.
- B. Securely mount adjacent to equipment on wall or acceptable mounting frame. Disconnect switches shall be mounted independent from the equipment they serve. Disconnects supported only by raceway are not acceptable.
- C. Wiring space within Disconnects, Fused Switches or Enclosed Circuit Breakers shall not be used for splices.
- D. Tighten electrical connectors and terminals according to manufacturer's published torque-tightening values. Where manufacturer's torque values are not indicated, use those specified in UL 486A and UL 486B.
- E. Temporary Lifting Provisions: Remove temporary lifting eyes, channels, and brackets and temporary blocking of moving parts from enclosures and components.
- F. Install fuses in fusible devices.
- G. Comply with NECA 1.

**KOPACHUCK STATE PARK
DAY USE DEVELOPMENT**

3.3 CLEANING

- A. After completing system installation, including outlet fittings and devices, inspect exposed finish. Remove burrs, dirt, and construction debris and repair damaged finish including chips, scratches, and abrasions.

3.4 IDENTIFICATION

- A. Comply with requirements in Division 26 Section "Identification for Electrical Systems."
 - 1. Identify field-installed conductors, interconnecting wiring, and components; provide warning signs.
 - 2. Label each enclosure with engraved metal or laminated-plastic nameplate.

3.5 FIELD QUALITY CONTROL

- A. Acceptance Testing Preparation:
 - 1. Test insulation resistance for each enclosed switch and circuit breaker, component, connecting supply, feeder, and control circuit.
 - 2. Test continuity of each circuit.

- B. Tests and Inspections:
 - 1. Perform each visual and mechanical inspection and electrical test stated in NETA Acceptance Testing Specification. Certify compliance with test parameters.
 - 2. Correct malfunctioning units on-site, where possible, and retest to demonstrate compliance; otherwise, replace with new units and retest.
 - 3. Perform the following infrared scan tests and inspections and prepare reports:
 - a. Initial Infrared Scanning: After Substantial Completion, but not more than 60 days after Final Acceptance, perform an infrared scan of each enclosed switch and circuit breaker. Remove front panels so joints and connections are accessible to portable scanner.
 - b. Follow-up Infrared Scanning: Perform an additional follow-up infrared scan of each enclosed switch and circuit breaker 11 months after date of Substantial Completion.
 - c. Instruments and Equipment: Use an infrared scanning device designed to measure temperature or to detect significant deviations from normal values. Provide calibration record for device.
 - 4. Test and adjust controls, remote monitoring, and safeties. Replace damaged and malfunctioning controls and equipment.

- C. Enclosed switches and circuit breakers will be considered defective if they do not pass tests and inspections.

**KOPACHUCK STATE PARK
DAY USE DEVELOPMENT**

- D. Prepare test and inspection reports, including a certified report that identifies enclosed switches and circuit breakers and that describes scanning results. Include notation of deficiencies detected, remedial action taken, and observations after remedial action.

3.6 ADJUSTING

- A. Adjust moving parts and operable components to function smoothly and lubricate as recommended by manufacturer.
- B. Set field-adjustable circuit-breaker trip ranges as directed.

END OF SECTION 262816

**KOPACHUCK STATE PARK
DAY USE DEVELOPMENT**

SECTION 265100 - INTERIOR LIGHTING

PART 1 - GENERAL

1.1 RELATED DOCUMENTS

- A. Drawings and general provisions of the Contract, including General Conditions and Division 01 Specification Sections, apply to this Section.

1.2 SUMMARY

A. Section Includes:

- 1. Interior lighting fixtures, lamps, and drivers.
- 2. Emergency lighting units.
- 3. Exit signs.
- 4. Lighting fixture supports.
- 5. Retrofit kits for fluorescent lighting fixtures.

B. Related Sections:

- 1. Section 260923 - Lighting Control Devices, for automatic control of lighting, including time switches, photoelectric relays, occupancy sensors, and multipole lighting relays and contactors.

1.3 REFERENCES

A. National Electrical Manufacturer's Association (NEMA) LE5-1993:

- 1. Procedure for determining Luminaire efficiency ratings.

B. Underwriters Laboratories, Inc. (UL):

UL 924:	Emergency Lighting and Power Equipment
UL 935:	Fluorescent Lamp Ballasts
UL 1012	Power Units Other Than Class 2
UL 1029:	HID Lamp Ballasts
UL 1310	Class 2 Power Units
UL 1570:	Fluorescent Lighting Fixtures
UL 1574:	Track Lighting Systems
UL 1598	Luminaires

**KOPACHUCK STATE PARK
DAY USE DEVELOPMENT**

1.4 DEFINITIONS

- A. CCT: Correlated color temperature.
- B. CRI: Color-rendering index.
- C. HID: High-intensity discharge.
- D. IP: International Protection or Ingress Protection Rating.
- E. LED: Light-emitting diode.
- F. LER: Luminaire efficacy rating.
- G. Lumen: Unit of luminous flux. Photometrically, it is the luminous flux emitted within a unit solid angle by a point source having a uniform luminous intensity of 1 candela.
- H. Luminaire: Complete lighting fixture, including driver, lamp, housing, parts designed to distribute the light, to position and protect the lamps, and to connect the lamps to the power supply.

1.5 SYSTEM DESCRIPTION

- A. Light fixture schedule series numbers are a design series reference and do not necessarily represent the exact catalog number, size, voltage, wattage, type of lamp, ballast, finish trim, ceiling type, mounting hardware, ceiling trim or special requirements as specified hereinafter or as required by the particular installations. Provide complete fixtures to correspond with the number of lamps, wattage and/or size specified.
- B. If there are discrepancies between fixture illustrations and the written description in the fixture schedule, the written description in the fixture schedule shall take precedence.
- C. Light fixture voltage shall match voltage of circuit serving the light fixture.

1.6 SUBMITTALS

- A. Product Data: For each type of lighting fixture, arranged in order of fixture designation include data on features, accessories, finishes, and the following:
 - 1. Physical description of lighting fixture including dimensions.
 - 2. Emergency lighting units including battery and charger.
 - 3. Ballast, including circuit type (Programmed start, instant start, etc) BF.
 - 4. Air and Thermal Performance Data: For air-handling lighting fixtures. Furnish data required in "Action Submittals" Article in Division 23.
 - 5. Sound Performance Data: For air-handling lighting fixtures. Indicate sound power level and sound transmission class in test reports certified according to standards specified in Division 23.
 - 6. Lamps including brand name, product name, rated life, output CCT, and CRI.
 - 7. Product Photometric data and adjustment factors based on laboratory tests, complying with IESNA Lighting Measurements Testing & Calculation Guides, of each lighting fixture type. The adjustment factors shall be for lamps, ballasts, and accessories identical to

KOPACHUCK STATE PARK DAY USE DEVELOPMENT

those indicated for the lighting fixture as applied in this Project. LED fixture testing shall comply with IES LM-79 and LM-80.

- B. Shop Drawings: For nonstandard or custom lighting fixtures. Include plans, elevations, sections, details, and attachments to other work.
 - 1. Detail equipment assemblies and indicate dimensions, weights, loads, required clearances, method of field assembly, components, and location and size of each field connection.
 - 2. Wiring Diagrams: For power, signal, and control wiring.
- C. Pendant support system if part of fixture.

1.7 CLOSEOUT SUBMITTALS

- A. Operation and Maintenance Data: For lighting equipment and fixtures to include in emergency, operation, and maintenance manuals.
 - 1. Provide a list of all lamp types used on Project; use ANSI and manufacturers' codes.
 - 2. Provide cut sheets of all fixtures and control devices.
 - 3. Provide instruction manuals for all control systems.

1.8 QUALITY ASSURANCE

- A. Luminaire Photometric Data Testing Laboratory Qualifications: Provided by manufacturers' laboratories that are accredited under the National Volunteer Laboratory Accreditation Program for Energy Efficient Lighting Products.
- B. Luminaire Photometric Data Testing Laboratory Qualifications: Provided by an independent agency, with the experience and capability to conduct the testing indicated, that is an NRTL as defined by OSHA in 29 CFR 1910, complying with the IESNA Lighting Measurements Testing & Calculation Guides.
- C. Provide luminaires from a single manufacturer for each luminaire type.
- D. For LEDs: Each luminaire type shall be binned within a three-step McAdam Ellipse to ensure color consistency among luminaires.
- E. Electrical Components, Devices, and Accessories: Listed and labeled as defined in NFPA 70, by a qualified testing agency, and marked for intended location and application.
- F. Comply with NFPA 70.

1.9 DELIVERY, STORAGE, AND HANDLING

- A. Protect finishes of exposed surfaces by applying a strippable, temporary protective covering before shipping.

**KOPACHUCK STATE PARK
DAY USE DEVELOPMENT**

1.10 WARRANTY

- A. Warranty: Manufacturer and Installer agree to repair or replace components of luminaires that fail in materials or workmanship within specified warranty period.
- B. Warranty Period: Five year(s) from date of Substantial Completion.
- C. Special Warranty for Emergency Lighting Batteries: Manufacturer's standard form in which manufacturer of battery-powered emergency lighting unit agrees to repair or replace components of rechargeable batteries that fail in materials or workmanship within specified warranty period.
 - 1. Warranty Period for Emergency Lighting Unit Batteries: 10 years from date of Substantial Completion. Full warranty shall apply for first year, and prorated warranty for the remaining nine years.
 - 2. Warranty Period for Self-Powered Exit Sign Batteries: Seven years from date of Substantial Completion. Full warranty shall apply for first year, and prorated warranty for the remaining six years.

PART 2 - PRODUCTS

2.1 GENERAL MATERIAL REQUIREMENTS

- A. Finish ferrous mounting hardware and accessories to prevent corrosion and discoloration to adjacent materials.
- B. For vapor tight installations, painted finishes of fixtures and accessories shall be weather resistant enamel using proper primers or galvanized and bonderized epoxy, so that the entire assembly is completely corrosion resistant for the service intended. Where aluminum parts come into contact with bronze or steel parts, apply a coating material to both surfaces to prevent corrosion.
- C. Fixtures shall be free of light leaks and designed to provide sufficient ventilation of lamps to provide the photometric performance required. Ballasts and transformers shall be adequately vented.
- D. All sheet metal work shall be free from tool marks and dents and shall have accurate angles bent as sharp as compatible with the gauges of the required metal. Intersections and joints shall be formed true and of adequate strength and structural rigidity to prevent any distortion after assembly. Finish exposed edges so no sharp or ragged edges are exposed. All miters shall be in accurate alignment with abutting intersecting members.
- E. Lampholders shall hold lamps securely against normal vibrations and maintenance handling.
- F. Reflector Cones:

**KOPACHUCK STATE PARK
DAY USE DEVELOPMENT**

1. Provide minimum 45° lamp and lamp image cut-off for all vertically mounted lamps. For horizontal lamps provide minimum 33° cut-off. There shall be no visible lamp flashing in the cone.
2. Plastic materials shall not be used for reflector cones, unless noted otherwise in the Light Fixture Schedule.
3. Reflector cones shall not be riveted or welded to housing and shall be removable without tools. Retention devices shall not deform the cone in any manner. Trim shall be flush with finished ceiling without gaps or light leaks. Where the flange trim is separate from the cone, it shall have the same finish as the cone.
4. Reflector cones shall be of uniform gauge, not less than 0.032-inch thick, high purity aluminum Alcoa 3002 alloy, free of spin marks or other defects.
5. Manufacture reflector under the Alzak process. Refer to fixture schedule for cone color and specular or diffuse finish requirements. For fixtures using compact fluorescent lamps, provide additional finish equivalent to Color-Chek that eliminates iridescence. Submit one sample of each cone type for review when required in the fixture schedule.

G. Fresnel Lens and Door Assembly:

1. Lens shall have uniform brightness throughout the entire visible area at angles from 45° to 90° from vertical, without bright spots or striations.
2. Lens shall have opaque risers painted neutral gray unless otherwise specified in the Light Fixture Schedule.
3. Finish of regress door shall be matte baked enamel paint in color as selected by the Architect.

H. Light fixtures containing lamps which require protective shielding shall have tempered glass lenses.

I. For adjustable fixtures, provide positive locking devices to fix aiming angle. Fixture shall be capable of being relamped without adjusting aiming angle.

J. Fixtures recessed in suspended ceilings where the space above the ceiling is either an air supply or return plenum shall conform to NEC Article 300-22.

K. Safety: Provide safety devices for removable fixture elements (cones, reflectors, lenses, etc.) to support removable elements when not in normal operating position. Safety devices shall be detachable if necessary and shall not interfere with fixture performance, maintenance or the seating of any fixture element, and not be visible during normal fixture operation.

2.2 PERFORMANCE REQUIREMENTS

A. Seismic Performance: Luminaires shall withstand the effects of earthquake motions determined according to ASCE/SEI 7.

B. Seismic Performance: Luminaires and lamps shall be labeled vibration and shock resistant.

1. Retain subparagraph below to define the term "withstand" as it applies to this Project. Definition varies with type of building and occupancy and is critical to valid certification.

**KOPACHUCK STATE PARK
DAY USE DEVELOPMENT**

Option is used for essential facilities where equipment must operate during and immediately after an earthquake.

2. The term "withstand" means "the luminaire will remain in place without separation of any parts when subjected to the seismic forces specified]."

C. Ambient Temperature: 5 to 104 deg F.

1. Relative Humidity: Zero to 95 percent.

2.3 FLUORESCENT FIXTURES

A. Housing: Minimum code gauge steel or rigid aluminum construction painted after fabrication with high reflectance white paint (min. 89%).

B. Light Shields:

1. Eggcrate Louvers: Aluminum (unless noted otherwise) continuously bound in a perimeter channel frame. Frame, louver and support shall be painted color as selected by Architect.
2. Parawedge Louvers: Injection molded plastic with specular silver finish 1/2" x 1/2" x 1/2" cell, unless otherwise specified anti-static finish.
3. Parabolic Louvers: Provide Alzak aluminum, specular or semi-specular as specified, with a low-iridescent finish.
4. Flat Translucent Diffusers: Shall be 100% virgin DR acrylic and have matte finish on exterior side (facing away from lamps). Diffuser shall be of thickness specified and shall be of sufficient density to completely obscure lamp image.
5. Flat Clear Lenses: Injection molded 100% virgin DR acrylic or clear tempered glass, thickness as specified.
6. Clear Patterned Lenses: Injection molded 100% virgin DR acrylic. For lenses with a male pattern of prisms or cones, specified minimum thickness refers to distance from flat surface to base of pyramids or cones, or to thickness of undisturbed material. For lenses with female pattern, specified minimum thickness refers to overall thickness of material. Lenses shall fully eliminate lamp image when viewed from all directions between 45-90° from vertical. From 0-45° the ratio of maximum brightness (under a lamp) to minimum brightness (mid-point between lamps) shall not exceed 3:1. Minimum thickness shall not be less than 0.125" with a minimum weight of 8 ounces per square foot.

C. Frames:

1. Supply with concealed hinges and latching. Provide mitered corners with no gaps or light leaks.

2.4 LIGHT EMITTING DIODE (LED) FIXTURES:

A. Housing: Rigid aluminum construction.

B. Finish: Visible surfaces. Powder coated paint or natural aluminum as specified in Light Fixture Schedule. Color and finish as selected by architect. Concealed parts, (lamp holders, yokes, brackets, etc.) matte black.

**KOPACHUCK STATE PARK
DAY USE DEVELOPMENT**

- C. Lamp Holder Housing: Cast aluminum with integral heat radiating fins to assure cool lamp base operation, with sufficient heat dissipation to meet device manufacturer's guidelines, certification programs, and test procedures for thermal management.
- D. Off-state Power: Luminaires shall not draw power in the off state. Exception: Luminaires with integral occupancy, motion, photo-controls or individually addressable fixtures with external control and intelligence are exempt from this requirement. The power draw for such luminaires shall not exceed 0.5 watts when in the off state.

2.5 WIRING

- A. Wiring shall be as required by code for fixture wiring.
- B. Flexible cord wiring between fixture components or to electrical receptacle and not in wireways shall have a minimum temperature rating of 105°C.
- C. Cords shall be fitted with proper strain reliefs and watertight entries where required by application.
- D. No internal wiring shall be visible at normal viewing angles, i.e. above 45° from vertical.
- E. Tandem Wired Fixtures: For fixtures in continuous rows and where required in Drawings or Light Fixture Schedule, supply ballasts and wiring to control all top or inboard lamps together and control all bottom or outboard lamps together.
- F. Provide #18 AWG, 3-wire flexible conduit connections (whips) for dual level switching as shown on Drawings for light fixtures recessed in accessible suspended ceilings. Provide 3-wire whips for all dual level switching. Wire count on wire whips is not shown on Drawings and shall be the responsibility of the Contractor to provide proper wire count for the lighting control as shown on Drawings.

2.6 POWER SUPPLIES:

- A. LED Power Supplies:
 - 1. Minimum power factor 90%.
 - 2. Minimum operating temperature of -20°C.
 - 3. Output operating frequency shall be minimum 120 Hz.
 - 4. Power supply shall meet FCC requirements for non-consumer use.
 - 5. Sound rating: Class A.
 - 6. Power supply shall comply with IEEE C.62.41-1991, Class A operation.

2.7 LAMPS

- A. Each lamp type in the Project shall be manufactured by the same manufacturer.
- B. Light Emitting Diode Type:

**KOPACHUCK STATE PARK
DAY USE DEVELOPMENT**

1. LED modules/arrays shall have a minimum CRI of 80 unless otherwise specified in the Light Fixture Schedule.
2. Color temperature variation shall not exceed +/- 100 degrees Kelvin at installation, and +/- 200 degrees Kelvin over the life of the module.
3. LED modules/arrays shall deliver at least 70% of initial lumens, when installed in-situ, for a minimum of 35,000 hours.

2.8 LIGHTING STANDARDS

- A. Pole/Luminaire Assemblies and Bollards: Supply luminaires, davit arms, brackets, poles, hand-hole covers, base components and all other accessories for a complete assembly. Manufacturer shall be responsible for proper fitting of all elements and the structural integrity of the unit.
- B. Provide insulating fuse and holder in the base of each lighting standard to individually protect each lighting fixture. Fuse holder similar to Buss style "HEX" (HEB permitted for 120V or 277V), with Buss fuse of appropriate ampacity and voltage. Provide fuse for each hot circuit wire; do not fuse neutral.

2.9 LUMINAIRE SUPPORT

- A. Single-Stem Hangers: 1/2-inch steel tubing with swivel ball fittings and ceiling canopy. Finish same as luminaire.
- B. Wires: ASTM A641/A641M, Class 3, soft temper, zinc-coated steel, 12 ga.
- C. Rod Hangers: 3/16-inch minimum diameter, cadmium-plated, threaded steel rod.
- D. Hook Hangers: Integrated assembly matched to luminaire, line voltage, and equipment with threaded attachment, cord, and locking-type plug.

2.10 EMERGENCY BATTERY PACKS

- A. Where fixtures are indicated or specified to have self-contained battery backup, provide battery pack(s) with 1100 lumen output or as indicated. Unit shall have high temperature nickel cadmium battery, automatic transfer switch, battery charger high frequency inverter, installed test/charging indicator and switch, dual voltage, and be UL listed to standard 924. Provide normal switching connection where indicated.
- B. Testing: Apply power for 24 hours, disconnect power observe, measure and record light output for specified 90-minute period. Continue to run on battery until automatic low battery cut-off circuit disconnects battery. Restore normal power and verify battery returns to charging mode.
- C. Warranty: Entire unit shall be warranted for 5 years, battery shall have 15-year life expectancy with 5 year full warranty and 7 additional years prorated warranty. Full warranty to cover labor and materials without charge. Prorated warranty to cover material only.

**KOPACHUCK STATE PARK
DAY USE DEVELOPMENT**

PART 3 - EXECUTION

3.1 EXAMINATION

- A. Examine substrates, areas, and conditions, with Installer present, for compliance with requirements for installation tolerances and other conditions affecting performance of the Work.
- B. Examine roughing-in for luminaire to verify actual locations of luminaire and electrical connections before luminaire installation.
- C. Proceed with installation only after unsatisfactory conditions have been corrected.

3.2 INSTALLATION

- A. Provide mounting accessories and trims for wall and ceiling construction types shown in Finish Schedule and on Drawings.
- B. Lighting fixtures:
 - 1. Set level, plumb, and square with ceilings and walls unless otherwise indicated.
 - 2. For fixtures with replaceable lamps, install lamps in each luminaire.
- C. Remote Mounting of Drivers: Distance between the ballast/driver and fixture not to exceed that recommended by ballast/driver manufacturer. Verify requirements for maximum distance between ballast/driver and luminaire with ballast/driver manufacturers.
- D. Verify weight and mounting method of fixtures and provide suitable supports. Fixture mounting assemblies to comply with local seismic codes and regulations.
- E. Refer to architectural reflected ceiling plans for coordination of lighting fixture locations with mechanical and fire safety equipment. Where conflicts occur, consult with Architect prior to installing any of the systems.
- F. For fire rated ceilings and walls, provide rated enclosure for recessed light fixture, or consult with Architect and Lighting Designer to specify fixture suitable for use in rated ceiling or wall.
- G. Install fixtures with vent holes free of air blocking obstacles.
- H. Lighting fixtures located in recessed ceilings with a fire resistive rating of 1-hour or more to be enclosed in an approved fire-resistive rated box equal to that of the ceiling.
- I. Adjust aperture rings on all recessed fixtures to be flush with the finished ceiling.
- J. Adjust variable position lampholders for proper lamp position prior to fixture installation.
- K. Blemished, damaged or unsatisfactory fixtures or accessories to be replaced with new.

**KOPACHUCK STATE PARK
DAY USE DEVELOPMENT**

- L. For pendant mounted fixtures, mounting height is from finished ceiling to top of pendant light fixture. For wall mounted fixtures, center on outlet box unless otherwise noted. Verify mounting provisions and other requirements prior to order of light fixtures.
- M. In accessible suspended ceilings, provide 72" flexible conduit wiring connection (flexible tubing not permitted) from a rigidly supported junction box.
- N. All finishes shall be unmarred upon project completion. Repair or replace damaged finishes.
- O. Replace all burned out or inoperative lamps and LED boards at the end of the construction prior to Owner occupancy. LED boards with visibly different color LEDs will be considered inoperative and require replacement.

3.3 DIFFUSERS AND ENCLOSURES

- A. Remove protective plastic covers from lighting fixture diffusers only after construction work, painting and clean-up are completed. Remove all dirty lamps, reflectors and diffusers; clean and reinstall. When cleaning "Alzak" reflectors, use a manufacturer recommended cleaning solution. Reflectors damaged or impregnated with fingerprints shall be replaced at no cost to Owner.
- B. For LED fixtures, whether surface mounted or recessed, remove all construction dirt and dust from heat sink fins to ensure proper dissipation of heat.

3.4 ADJUSTMENT OF LIGHT FIXTURES

- A. Focus all adjustable light fixtures under the direction of the Lighting Designer during a scheduled period of time prior to the completion of the project, after normal business hours if required. Include all equipment and personnel expenses (including overtime) required for adjustment.

3.5 DOWNLIGHT/ACCENT/WALL WASH LIGHT FIXTURE SUPPORT

- A. Surface or Pendant Type: Attach heavy formed steel straps to the outlet box by means of threaded stems with locknuts, or directly to the outlet box where the light fixture is specifically so designed.
- B. Recessed Type: Mount in frames suitable for the ceiling, with recessed portion of the fixture securely supported from the ceiling framing. Bottom of light fixture to be flush with adjacent ceiling. Fixture trim shall totally conceal ceiling opening. Provide two #14 earthquake chains or #12 wires when fixture is supported by ceiling suspension system.
- C. Provide access as required for driver. Provide earthquake chains when light fixture is supported by the ceiling suspension system. For remote ballasts/drivers, isolate ballast/driver from structure.

**KOPACHUCK STATE PARK
DAY USE DEVELOPMENT**

3.6 TROFFER AND LINEAR TYPE LIGHT FIXTURE SUPPORT

- A. Recessed type: For light fixtures supported by the ceiling suspension system, provide four Caddy #515 support clips (one each corner) which lock light fixture to ceiling tees after light fixture is installed. In addition, provide for each light fixture two #14 earthquake chains or #12 wires secured at diagonally opposite fixture corners (for fixtures weighing less than 56 pounds) to structural members above suspended ceiling. For plaster or gypsum board ceilings provide plaster frame compatible with light fixture. Contractor shall coordinate fixture trim with ceiling type.
- B. Surface Mounted Type:
 - 1. Where mounted on accessible ceilings, support from structural members above ceiling by means of hanger rods through ceiling or as approved.
 - 2. Continuous Runs of Fixtures: Laser sight to assure fixtures are straight when sighting from end to end, regardless of irregularities in the ceiling. Where light fixtures are so installed, omit ornamental ends between sections.
- C. Pendant Mounted Type:
 - 1. For fixtures with rigid pendants, supply swivel ball aligners at canopy to comply with local seismic requirements.
 - 2. Where suspended from accessible ceiling, support fixture from structural members above ceiling by means of hanger rods through ceiling or as accepted.
 - 3. Continuous Runs of Light Fixtures: Laser sight to assure fixtures are straight when sighting from end to end, regardless of irregularities in the ceiling. Where light fixtures are so installed, omit ornamental ends between sections.
 - 4. Where pendant is longer than 48 inches (1200mm), brace to limit swinging.

3.7 CEILING AND WALL LIGHT FIXTURE SUPPORT

- A. Where ceiling and/or wall are of insufficient strength to support weight of lighting fixtures installed, provide additional framing to support as required.

END OF SECTION 265100

**KOPACHUCK STATE PARK
DAY USE DEVELOPMENT**

SECTION 265600 - EXTERIOR LIGHTING

PART 1 - GENERAL

1.1 RELATED DOCUMENTS

- A. Drawings and general provisions of the Contract, including General Conditions and Division 1 Specification Sections, apply to this Section.

1.2 SUMMARY

- A. Section Includes:
 - 1. Exterior luminaires.
 - 2. Poles and accessories.
 - 3. Foundations

1.3 DEFINITIONS

- A. CCT: Correlated color temperature.
- B. CRI: Color-rendering index.
- C. LER: Luminaire efficacy rating.
- D. Luminaire: Complete lighting fixture, LED board, including driver, reflector, wiring and housing.
- E. Pole: Luminaire support structure, including tower used for large area illumination.
- F. Standard: Same definition as "Pole" above.

1.4 REFERENCES

- A. Underwriters Laboratories, Inc. (UL):
 - UL 924: Emergency Lighting and Power Equipment
 - UL 1012 Power Units Other Than Class 2
 - UL 1310 Class Power Units
 - UL 1570: Fluorescent Lighting Fixtures
 - UL 1598 Luminaires
 - UL 1838 Low Voltage Landscape Lighting Systems
 - UL 1994 Luminous Egress Path Marking Systems

**KOPACHUCK STATE PARK
DAY USE DEVELOPMENT**

1.5 SUBMITTALS

- A. For standard catalog items, provide original product sheets, -neatly and clearly marked- to indicate that light fixture, driver and LED boards fully comply with contract documents.
- B. Submittals shall have fixture types and project name clearly indicated and shall be prepared by the authorized manufacturer's representative serving the project area. A list of manufacturer's representatives (including website and telephone number) identifying which light fixture types they represent shall be included with submittals. Submittals or requests for substitutions not meeting these requirements will be rejected.
- C. Product Data: For each type of luminaire
 - 1. Arrange in order of luminaire designation.
 - 2. Include data on features, accessories, and finishes.
 - 3. Include physical description and dimensions of luminaire.
 - 4. Lamps, include life, output (lumens, CCT, and CRI), and energy-efficiency data.
 - 5. Photometric data and adjustment factors based on laboratory tests, complying with IES LM-79 and IES LM-80.
 - a. Manufacturer's Certified Data: Photometric data certified by manufacturer's laboratory with a current accreditation under the NVLAP for Energy Efficient Lighting Products.
 - b. Testing Agency Certified Data: For indicated luminaires, photometric data certified by a qualified independent testing agency. Photometric data for remaining luminaires shall be certified by manufacturer.
 - 6. Wiring diagrams for power, control, and signal wiring.
 - 7. Photoelectric relays.
 - 8. Means of attaching luminaires to supports and indication that the attachment is suitable for components involved.
- D. Shop Drawings: For nonstandard or custom luminaires.
 - 1. Include plans, elevations, sections, and mounting and attachment details.
 - 2. Include details of luminaire assemblies. Indicate dimensions, weights, loads, required clearances, method of field assembly, components, and location and size of each field connection.
 - 3. Include diagrams for power, signal, and control wiring.
- E. Pole and Support Component Certificates: Signed by manufacturers of poles, certifying that products are designed for indicated load requirements in AASHTO LTS-5-E and that load imposed by luminaire and attachments has been included in design. The certification shall be based on design calculations by a professional engineer.

**KOPACHUCK STATE PARK
DAY USE DEVELOPMENT**

1.6 CLOSEOUT SUBMITTALS

- A. Operation and Maintenance Data: For luminaires and photoelectric relays to include in operation and maintenance manuals.
 - 1. Provide a list of all photoelectric relay types used on Project; use manufacturers' codes.

1.7 DELIVERY, STORAGE AND HANDLING

- A. Protect finishes of exposed surfaces by applying a strippable, temporary protective covering prior to shipping.

1.8 FIELD CONDITIONS

- A. Verify existing and proposed utility structures prior to the start of work associated with luminaire installation.
- B. Mark locations of exterior site luminaires for approval by Architect prior to the start of luminaire installation.

1.9 WARRANTY

- A. Warranty: Manufacturer and Installer agree to repair or replace components of luminaires that fail in materials or workmanship within specified warranty period.
 - 1. Failures include, but are not limited to, the following:
 - a. Structural failures, including luminaire support components.
 - b. Faulty operation of luminaires and accessories.
 - c. Deterioration of metals, metal finishes, and other materials beyond normal weathering.
 - 2. Warranty Period: **5** year(s) from date of Substantial Completion.

PART 2 - PRODUCTS

2.1 GENERAL MATERIAL REQUIREMENTS

- A. Finish mounting hardware and accessories to prevent corrosion and discoloration to adjacent materials.
- B. For weatherproof or vaportight installations, painted finishes of fixtures and accessories shall be weather resistant enamel using proper primers or galvanized and bonderized epoxy, so that the entire assembly is completely corrosion resistant for the service intended. Where aluminum parts come into contact with bronze or steel parts, apply a coating material to both surfaces to prevent corrosion.

**KOPACHUCK STATE PARK
DAY USE DEVELOPMENT**

- C. Non-vapor tight fixtures to have 1/8" dia. weep holes as required for proper drainage. Weep holes to be configured to prevent light leaks.
- D. Fixtures shall be free of light leaks and designed to provide sufficient ventilation of LED and other electronic parts to provide the photometric performance required. Drivers and transformers shall be adequately vented.
- E. Light fixtures containing optics which require protective shielding shall have tempered clear glass lenses, unless noted otherwise in the Light Fixture Schedule.
- F. Safety: Provide safety devices for removable fixture elements (cones, reflectors, lenses, etc.) to support removable elements when not in normal operating position. Safety devices shall be detachable if necessary and shall not interfere with fixture performance, maintenance or the seating of any fixture element, and not be visible during normal fixture operation. Safety device shall be made of corrosion resistant materials.
- G. Finishes:
 - 1. Painted surfaces shall have an outdoor life expectancy of not less than 20 years without any visible rust or corrosion.
 - 2. Finishes to comply with requirements set by the American Architectural Manufacturers Association (AAMA):
 - a. Baked on enamel and high performance powder coating finish on aluminum: AAMA 304-05
 - b. Anodized aluminum: AAMA 611-98
 - c. Clear coat on aluminum: AAMA 612-02
 - 3. Finish colors shall be as specified.
- H. Diffusers: materials shall be UV stabilized.

2.2 LIGHT EMITTING DIODE (LED) FIXTURES:

- A. Housing: Rigid aluminum construction.
- B. Finish: Visible surfaces. Powder coated paint or natural aluminum as specified in Light Fixture Schedule. Color and finish as selected by architect.
- C. Lamp Holder Housing: Cast aluminum with integral heat radiating fins to assure cool lamp base operation, with sufficient heat dissipation to meet device manufacturer's guidelines for junction temperature, certification programs, and test procedures for thermal management.
- D. Off-state Power: Luminaires shall not draw power in the off state. Exception: Luminaires with integral occupancy, motion, photo-controls or individually addressable fixtures with external control and intelligence are exempt from this requirement. The power draw for such luminaires shall not exceed 0.5 watts when in the off state.

**KOPACHUCK STATE PARK
DAY USE DEVELOPMENT**

2.3 WIRING

- A. Wiring shall be as required by code for fixture wiring.
- B. Flexible cord wiring between fixture components or to electrical receptacle and not in wireways shall have a minimum temperature rating of 105°C.
- C. Cords shall be fitted with proper strain reliefs and watertight entries where required by application.
- D. No internal wiring shall be visible at normal viewing angles, i.e. above 45° from vertical.

2.4 DRIVERS AND POWER SUPPLIES:

- A. LED Power Supplies:
 - 1. Minimum power factor 90%.
 - 2. Minimum operating temperature of -20°C.
 - 3. Output operating frequency shall be minimum 120 Hz.
 - 4. Power supply shall meet FCC requirements for non-consumer use.
 - 5. Sound rating: Class A.
 - 6. Power supply shall comply with IEEE C.62.41-1991, Class A operation.

2.5 LAMPS

- A. Light Emitting Diode Type:
 - 1. CRI of minimum 80 . CCT of 3000 K.
 - 2. L70 lamp life of **50,000** hours.
 - 3. Lamps dimmable from 100 percent to 1 percent of maximum light output.
 - 4. Nominal Operating Voltage: Per electrical drawings
 - 5. Source Limitations: Obtain luminaires from a single manufacturer for each type designation.

2.6 LIGHTING STANDARDS

- A. Pole/Luminaire Assemblies and Bollards: Supply luminaires, davit arms, brackets, poles, handhole covers, base components and all other accessories for a complete assembly. Manufacturer shall be responsible for proper fitting of all elements and the structural integrity of the unit. Provide assembly to withstand 100 mph steady wind rated poles with 1.3 gust factor.
- B. Provide watertight insulating fuse and holder in the base of each lighting standard to individually protect each lighting fixture. Fuse holder similar to Buss style "HEX" (HEB permitted for 120V or 277V), with Buss fuse of appropriate ampacity and voltage. Provide fuse for each hot circuit wire; do not fuse neutral.

**KOPACHUCK STATE PARK
DAY USE DEVELOPMENT**

2.7 GENERAL REQUIREMENTS FOR POLES AND SUPPORT COMPONENTS

- A. Structural Characteristics: Comply with AASHTO LTS-5-E
 - 1. Wind-Load Strength of Poles: Adequate at indicated heights above grade without failure, permanent deflection, or whipping in steady winds of speed indicated in "Structural Analysis Criteria for Pole Selection" Article.
 - 2. Strength Analysis: For each pole, multiply the actual equivalent projected area of luminaires and brackets by a factor of 1.1 to obtain the equivalent projected area to be used in pole selection strength analysis.
- B. Luminaire Attachment Provisions: Comply with luminaire manufacturers' mounting requirements. Use stainless-steel fasteners and mounting bolts unless otherwise indicated.
- C. Mountings, Fasteners, and Appurtenances: Corrosion-resistant items compatible with support components.
 - 1. Materials: Shall not cause galvanic action at contact points.
 - 2. Anchor Bolts, Leveling Nuts, Bolt Caps, and Washers: Hot-dip galvanized after fabrication unless otherwise indicated.
 - 3. Anchor-Bolt Template: Plywood or steel.
- D. Handhole: Oval-shaped, with minimum clear opening of 2-1/2 by 5 inches, with cover secured by stainless-steel captive screws.
- E. Concrete Pole Foundations: Cast in place, with anchor bolts to match pole-base flange.
- F. Wind Load: Provide pressure of wind on pole and luminaire and banners and banner arms, calculated and applied as stated in AASHTO LTS-5-E.

2.8 STEEL POLES

- A. Poles: Comply with ASTM A 500, Grade B, carbon steel with a minimum yield of 46,000 psig one-piece construction up to 40 feet in height with access handhole in pole wall.
 - 1. Shape: Square, straight.
 - 2. Mounting Provisions: Butt flange for bolted mounting on foundation or breakaway support.
- B. Steel Mast Arms: Continuously welded to pole attachment plate. Material and finish same as pole.
- C. Brackets for Luminaires: Detachable, cantilever, without underbrace.
 - 1. Adapter fitting welded to pole, allowing the bracket to be bolted to the pole mounted adapter, then bolted together with galvanized steel bolts.
 - 2. Cross Section: Tapered oval, with straight tubular end section to accommodate luminaire.
 - 3. Match pole material and finish.

**KOPACHUCK STATE PARK
DAY USE DEVELOPMENT**

- D. Pole-Top Tenons: Fabricated to support luminaire or luminaires and brackets indicated, and securely fastened to pole top.
- E. Grounding and Bonding Lugs: Welded 1/2-inch threaded lug, complying with requirements in Division 26 Section "Grounding and Bonding for Electrical Systems," listed for attaching grounding and bonding conductors of type and size listed in that Section, and accessible through handhole.
- F. Cable Support Grip: Wire-mesh type with rotating attachment eye, sized for diameter of cable and rated for a minimum load equal to weight of supported cable times a 5.0 safety factor.
- G. Factory-Painted Finish: Comply with NAAMM's "Metal Finishes Manual for Architectural and Metal Products" for recommendations for applying and designating finishes.
 - 1. Surface Preparation: Clean surfaces to comply with SSPC-SP 1, "Solvent Cleaning," to remove dirt, oil, grease, and other contaminants that could impair paint bond. Grind welds and polish surfaces to a smooth, even finish. Remove mill scale and rust, if present, from uncoated steel, complying with SSPC-SP 5/NACE No. 1, "White Metal Blast Cleaning," or with SSPC-SP 8, "Pickling."
 - 2. Interior Surfaces of Pole: One coat of bituminous paint, or otherwise treat for equal corrosion protection.
 - 3. Exterior Surfaces: Manufacturer's standard finish consisting of one or more coats of primer and two finish coats of high-gloss, high-build polyurethane enamel.
 - a. Color: Dark Bronze.

PART 3 - EXECUTION

3.1 EXAMINATION

- A. Examine substrates, areas, and conditions, with Installer present, for compliance with requirements for installation tolerances and other conditions affecting performance of the Work.
- B. Examine roughing-in for luminaire electrical conduit to verify actual locations of conduit connections before luminaire installation.
- C. Proceed with installation only after unsatisfactory conditions have been corrected.

3.2 LIGHTING FIXTURES, GENERAL

- A. Comply with NECA 1.
- B. Use fastening methods and materials selected to resist seismic forces defined for the application and approved by manufacturer.
- C. Fasten luminaire to structural support.
- D. Supports:

**KOPACHUCK STATE PARK
DAY USE DEVELOPMENT**

1. Sized and rated for luminaire weight.
 2. Support luminaires without causing deflection of finished surface.
 3. Luminaire-mounting devices shall be capable of supporting a horizontal force of 100 percent of luminaire weight and a vertical force of 400 percent of luminaire weight.
- E. Wall-Mounted Luminaire Support:
1. Attached to a minimum 1/8 inch backing plate attached to wall structural members.
- F. Wiring Method: Install cables in raceways. Conceal raceways and cables.
- G. For pole mounted fixtures or bollards, install luminaires level, plumb, and square with finished grade unless otherwise indicated. For wall mounted fixtures install luminaires at height and aiming angle as indicated on Drawings.
- H. Coordinate layout and installation of luminaires with other construction.
- I. Lighting fixtures located in recessed ceilings with a fire resistive rating of 1-hour or more shall be enclosed in an approved fire-resistive rated box equal to that of the ceiling.
- J. Adjust aperture rings on all recessed fixtures to be flush with the finished ceiling.
- K. Adjust luminaires that require field adjustment or aiming. Include adjustment of photoelectric device to prevent false operation of relay by artificial light sources, favoring a north orientation.
- L. Comply with requirements in Section 260519 - Low Voltage Electrical Power Conductors and Cables and Section 260533 - Raceways and Boxes for Electrical Systems for wiring connections and wiring methods.
- M. All finishes shall be unmarred upon project completion. Repair or replace damaged finishes.
- N. For pendant mounted fixtures, mounting height is from finished ceiling to top of pendant light fixture. For wall mounted fixtures, center on outlet box unless otherwise noted. Verify mounting provisions and other requirements prior to order of light fixtures and provide as required.
- O. In accessible suspended ceilings, provide 72" flexible conduit wiring connection (flexible tubing not permitted) from a rigidly supported junction box.
- P. Replace all burned out or inoperative lamps at the end of the construction prior to Owner occupancy.
- Q. Adjust luminaires that require field adjustment or aiming. Include adjustment of photoelectric device to prevent false operation of relay by artificial light sources, favoring a north orientation. Adjustments shall occur during a scheduled period of time prior to the completion of the project, after normal business hours if required. Include all equipment and personnel expenses (including overtime) required for adjustment.

**KOPACHUCK STATE PARK
DAY USE DEVELOPMENT**

- R. Comply with requirements in Section 260519 - Low-Voltage Electrical Power Conductors and Cables and Section 260533 - Raceways and Boxes for Electrical Systems for wiring connections and wiring methods.

3.3 DIFFUSERS AND ENCLOSURES

- A. Remove protective plastic covers from lighting fixture diffusers only after construction work, painting and clean-up are completed. Remove all dirty lamps, reflectors and diffusers; clean and reinstall. When cleaning "Alzak" reflectors, use a manufacturer recommended cleaning solution. Reflectors damaged or impregnated with fingerprints shall be replaced at no cost to Owner.
- B. For LED fixtures, whether surface mounted or recessed, remove all construction dirt and dust from heat sink fins to ensure proper dissipation of heat.

3.4 INSTALLATION OF INDIVIDUAL GROUND-MOUNTED LUMINAIRES

- A. Aim as indicated on drawings under the direction of the Architect after trees are planted.
- B. Install on concrete base with top **4 inches** above finished grade or surface at luminaire location. Cast conduit into base, and finish by troweling and rubbing smooth. Concrete materials, installation, and finishing are specified in Section 033000 "Cast-in-Place Concrete."

3.5 POLE INSTALLATION

- A. Alignment: Align pole foundations and poles for optimum directional alignment of luminaires and their mounting provisions on the pole.
- B. Clearances: Maintain the following minimum horizontal distances of poles from surface and underground features unless otherwise indicated on Drawings:
 - 1. Fire Hydrants and Storm Drainage Piping: **60 inches**.
 - 2. Water, Gas, Electric, Communication, and Sewer Lines: **10 feet**.
 - 3. Trees: **10 feet** from tree trunk.
- C. Concrete Pole Foundations: Set anchor bolts according to anchor-bolt templates furnished by pole manufacturer. Concrete materials, installation, and finishing requirements are specified in Division 03 Section "Cast-in-Place Concrete."
- D. Foundation-Mounted Poles: Mount pole with leveling nuts, and tighten top nuts to torque level recommended by pole manufacturer.
 - 1. Use anchor bolts and nuts selected to resist seismic forces defined for the application and approved by manufacturer.
 - 2. Grout void between pole base and foundation. Use non-shrink or expanding concrete grout firmly packed to fill space.
 - 3. Install base covers unless otherwise indicated.

KOPACHUCK STATE PARK DAY USE DEVELOPMENT

4. Use a short piece of 1/2-inch diameter pipe to make a drain hole through grout. Arrange to drain condensation from interior of pole.

E. Poles and Pole Foundations Set in Concrete Paved Areas: Install poles with minimum of 6-inch wide, unpaved gap between the pole or pole foundation and the edge of adjacent concrete slab. Fill unpaved ring with to a level 1 inch below top of concrete slab.

F. Raise and set poles using web fabric slings (not chain or cable).

3.6 LIGHTING STANDARDS

A. Provide rebar reinforced concrete base. For bolted poles, provide galvanized anchor bolts and nuts and plumb to true vertical using a nut above and below the base plate on the anchor bolts. Pack grout between base plate and concrete base and provide drain hole below base plate to prevent accumulation of moisture inside pole base. Provide two piece or individual covers for nuts exposed above the baseplate of the same color as the pole. Ground pole and light fixture.

3.7 CORROSION PREVENTION

A. Aluminum: Do not use in contact with earth or concrete. When in direct contact with a dissimilar metal, protect aluminum by insulating fittings or treatment.

B. Steel Conduits: Comply with Division 26 Section "Raceway and Boxes for Electrical Systems." In concrete foundations, wrap conduit with 0.010-inch thick, pipe-wrapping plastic tape applied with a 50 percent overlap.

3.8 GROUNDING

A. Ground metal poles and support structures according to Division 26 Section "Grounding and Bonding for Electrical Systems."

1. Install grounding electrode for each pole unless otherwise indicated.
2. Install grounding conductor pigtail in the base for connecting luminaire to grounding system.

B. Ground nonmetallic poles and support structures according to Division 26 Section "Grounding and Bonding for Electrical Systems."

1. Install grounding electrode for each pole.
2. Install grounding conductor and conductor protector.
3. Ground metallic components of pole accessories and foundations.

**KOPACHUCK STATE PARK
DAY USE DEVELOPMENT**

3.9 IDENTIFICATION

- A. Identify system components, wiring, cabling, and terminals. Comply with requirements for identification specified in Section 260553 "Identification for Electrical Systems."

3.10 FIELD QUALITY CONTROL

- A. Inspect each installed fixture for damage. Replace damaged fixtures and components.
- B. Perform the following tests and inspections with the assistance of a factory-authorized service representative:
 - 1. Operational Test: After installing luminaires, switches, and accessories, and after electrical circuitry has been energized, test units to confirm proper operation.
 - 2. Verify operation of photoelectric controls.
- C. Luminaire will be considered defective if it does not pass tests and inspections.
- D. Prepare a written report of tests, inspections, observations, and verifications indicating and interpreting results. If adjustments are made to lighting system, retest to demonstrate compliance with standards.

END OF SECTION 265600

**KOPACHUCK STATE PARK
DAY USE DEVELOPMENT**

SECTION 270500 - COMMON WORK RESULTS FOR COMMUNICATIONS

PART 1 - GENERAL

1.1 RELATED DOCUMENTS

- A. Drawings and general provisions of the Contract, including General Conditions and Division 1 Specification Sections, apply to this Section.
- B. Section 270526 – Grounding and Bonding for Communications Systems
- C. Section 270529 – Hangers and Supports for Communications Systems
- D. Section 270533 – Conduits and Backboxes for Communications Systems
- E. Section 271100 - Communications Equipment Room Fittings

1.2 SUMMARY

- A. This section includes general requirements for all Division 27 work and is supplemental and in addition to the requirements of Division 1.
- B. It is the intention of this Division of the Specifications and the Contract Drawings to describe and provide for the furnishing, installing, testing and placing in satisfactory and fully operational condition all equipment, materials, devices and necessary appurtenances to provide a complete communication system. Provide all materials, appliances and apparatus not specifically mentioned herein or shown on the drawings, but which are necessary to make a complete, fully operational installation of all communications systems shown on the contract drawings or described herein. Connect equipment and devices furnished and installed under other Divisions of this specification (or the Owner) under this Division.
- C. Workmanship shall be of the best quality and competent and experienced technicians shall be employed and shall be under the supervision of a competent and experienced foreman.
- D. The drawings and specifications are complementary and what is called for (or shown) in either is required to be provided as if called for in both. Where conflicting information occurs within the drawings and specifications or between the drawings and specifications, the more expensive alternative shall be used as a basis for bidding and construction.
- E. See Division 01 for sequence of work.

1.3 WORK IN OTHER DIVISIONS

- A. See all other specifications for other work which includes but is not limited to:
 - 1. Cutting and Patching
 - 2. Door Hardware

**KOPACHUCK STATE PARK
DAY USE DEVELOPMENT**

3. Electronic Safety and Security
4. Equipment Wiring
5. Interior Lighting
6. Lightning Protection Systems
7. Lighting Control Systems
8. Architectural Ceiling Systems
9. Fire Stopping
10. Mechanical Control Wiring
11. Mechanical Equipment
12. Painting, Refinishing and Finishes
13. Temporary Power

1.4 CODES, PERMITS, INSPECTION FEES

- A. The following codes and standards are referenced in the Division 27 specifications. Perform all work and provide materials and equipment in accordance with the latest referenced codes and standards of the following organizations:

1. American National Standards Institute (ANSI)
2. National Electrical Manufacturer's Association (NEMA)
3. National Fire Protection Association (NFPA)
4. Underwriter's Laboratories (UL)
5. American Society for Testing and Materials (ASTM)
6. BICSI (A Telecommunications Association)
7. International Building Code (IBC)
8. Insulated Cable Engineers Association (ICEA)
9. Institute of Electrical and Electronic Engineers (IEEE)
10. Federal Communications Commission Rules and Regulations (FCC)
11. National Electrical Code (NFPA Article 70) (NEC)
12. National Electrical Safety Code (NESC)
13. Occupational Safety and Health Administration (OSHA)
14. Rural Utilities Service (RUS)
15. Telecommunications Industry Association (TIA)
16. Electronics Industry Alliance (EIA)
17. Uniform Building Code (UBC)
18. UL 2043 & UL 2239
19. NEMA VE1 & VE2

- B. Install the communications systems based on the following:

1. NFPA 70 National Electrical Code as adopted and amended by the Local Jurisdiction.
2. IBC International Building Code as adopted and amended by the Local Jurisdiction.

- C. Communications Specific:

1. ANSI/TIA-526-7-A: Measurement of Optical Power Loss of Installed Single-mode Fiber Cable Plant.

**KOPACHUCK STATE PARK
DAY USE DEVELOPMENT**

2. ANSI/TIA-526-14-C: Measurement of Optical Power Loss of Installed Multimode Fiber Cable Plant.
3. ANSI/TIA-568.0-D: Generic Telecommunications Cabling for Customer Premises.
4. ANSI/TIA-568.1-D: Commercial Building Telecommunications Infrastructure Standard
5. ANSI/TIA-568-2.D: Balanced Twisted Pair Telecommunications Cabling and Components Standards
6. ANSI/TIA-568.3-D: Optical Fiber Cabling Components Standard
7. ANSI/TIA-568.4-D: Broadband Coaxial Cabling and Components Standard.
8. ANSI/TIA-569-D: Telecommunications Pathways and Spaces
9. ANSI/TIA-606-C: Administration Standard for Telecommunications Infrastructure
10. ANSI/TIA-607-C: Generic Telecommunications Bonding and Grounding (Earthing) for Customer Premises
11. ANSI/TIA-758-B: Customer-owned Outside Plant Telecommunications Infrastructure Standard
12. ANSI/TIA-862-B: Structured Cabling Infrastructure Standard for Intelligent Building Systems
13. ANSI/TIA-942-B: Telecommunications Infrastructure Standard for Data Centers
14. ANSI/TIA-1179-A: Healthcare Facility Telecommunications Infrastructure Standard
15. ANSI/TIA-4966: Telecommunications Infrastructure Standard for Educational Facilities
16. TIA: Technical Service Bulletins (TSBs) (related to the above ANSI/TIA standards)
17. IEEE 802.11 Wireless Local Area Network Standard, including the IEEE 802.11a, 802.11b, 802.11g, and 802.11n standards
18. BICSI: BICSI Customer Owned Outside Plant Design Manual, Latest Edition
19. BICSI: BICSI LAN and Internetworking Design Manual, Latest Edition
20. BICSI: BICSI Telecommunications Distribution Methods Manual, Latest Edition
21. BICSI: BICSI Telecommunications Cabling Installation Manual, Latest Edition
22. NEC: NFPA 70
23. FCC Part 68: Connection of Terminal Equipment to Telephone Network.

- D. The referenced codes and standards establish a minimum level of requirements. Where provision of the various codes conflict with each other, the more stringent provision shall govern. If any conflict occurs between referenced codes and this specification, the codes are to govern. Compliance with code requirements shall not be construed as relieving the Contractor from complying with any requirements of the drawings or specifications which may be in excess of requirements of the governing codes and rules and not contrary to same.
- E. Obtain and pay for all licenses, permits and inspections required by laws, ordinances and rules governing work specified herein. Arrange for inspection of work by the inspectors and give the inspectors all necessary assistance in their work of inspection.

1.5 COORDINATION

- A. Coordinate work with that of the other Contractors and/or other trades doing work on the project. Examine all drawings and specifications of other trades for construction details and coordination. Make every reasonable effort to provide timely notice of work affecting other trades to prevent conflicts or interference as to space requirements, dimensions, openings, block-outs, sleeving or other matters which will cause delays or necessitate work-around methods.

**KOPACHUCK STATE PARK
DAY USE DEVELOPMENT**

- B. Obtain submittals and shop drawings of all equipment with communications connections furnished under other divisions of the specification and by the Owner. Provide all wiring in accordance with specific equipment requirements. Immediately advise the Architect of any changes which may affect the contract price.
- C. Special attention is called to the following items. Coordinate all conflicts prior to installation:
 - 1. Location of grilles, pipes, sprinkler heads, ducts and other mechanical equipment so that all communications outlets and equipment are clear from and in proper relation to these items.
 - 2. Location of cabinets, counters and doors so that communications outlets, and equipment are clear from and in proper relation to these items.
 - 3. Recessing and concealing communications materials in CMU walls, concrete construction and precast construction.
 - 4. In every telecommunication room with either active or passive equipment the Contractor shall monitor the work of all trades to assure that the space and clearance requirements of code are met.
 - 5. Review specifications for other Divisions of the work to determine where other Divisions are requiring communication connections. Verify provisions shown on contract drawings by examining shop drawing submittals of other Divisions prior to submission to the Owner. Do not proceed with ordering of supporting equipment, until characteristics are verified. Proceed with rough-in only after verification of shop drawings.
- D. Digital format copies of bid drawings will be furnished to the successful bidder. Augment bid documents with additional information to ensure coordination between trades. Provide digital format communications systems drawings showing all ceiling devices, fixtures, raceways and cable tray locations and routing to mechanical contractor to be used for coordination drawings provided by mechanical contractor. Include dimensions and elevations of devices, fixtures, raceway and cable tray.
- E. Furnish, install and place in satisfactory condition all raceways, boxes, conductors and connections and all other materials required for the communication systems shown or noted in the contract documents to be complete, fully operational and fully tested upon completion of the project. Raceways, boxes and ground connections are shown diagrammatically only and indicate the general character and approximate location. Where routings of major raceways and telecommunication pathways are indicated on plan sheets, the routing information supplements the information on diagrams. If no routing information is shown, route the systems in a manner that will coordinate with new and existing infrastructure and the work of other trades.
- F. Consult the architectural drawings for the exact height and location of all communication equipment not specified herein or shown on the drawings. Make any minor changes (less than 6'-6" horizontal) in the location of the raceways, outlets, boxes, devices, wiring, etc., from those shown on the drawings without extra charge, where coordination requires or if so directed by the Architect before rough-in.
- G. Provide inserts or sleeves for outlet boxes, conductors, cables and/or raceways as required. Coordinate the installation thereof with other trades.
- H. The Contractor will not be paid for relocation of work, cuttings, patching and finishing required for work requiring reinstallation due to lack of coordination prior to installation.

**KOPACHUCK STATE PARK
DAY USE DEVELOPMENT**

1.6 WARRANTY

- A. Refer to Section 017700 – Closeout Procedures.

1.7 SUBMITTALS AND SHOP DRAWINGS

- A. Submittals and Shop Drawings: Prepared under the direct supervision of a BICSI RCDD. Submit electronically in portable document format (PDF). Schedule so as not to delay construction schedule and no later than 30 days after award of contract. Submit common brochure(s) with index and divider tabs by specification section, containing all required catalog cuts. Allow two weeks for review for each submittal and resubmittal. Incomplete submittals and shop drawings which do not comply with these requirements will be returned for correction, revision and resubmittal.
- B. Product Submittals:
1. Indicate listing by UL or other approved testing agency.
 2. Highlight electronically with yellow, blue, or red adequate information to demonstrate materials being submitted fully comply with contract documents.
 3. Review and check all material prior to submittal and stamp "Reviewed and Approved".
 4. Provide Manufacturer and/or lab certification that all product materials are PCB-free.
- C. Contractor Qualification Data: Provide most recent valid certification documentation for installation technician, installation supervisor, and field inspector and years of experience. These include BICSI ITS Installation Certifications and all relevant specific manufacture product installation certifications.
- D. Shop drawings shall show:
1. Ratings of items and systems.
 2. How the components of an item or system are assembled, interconnected, function together and how they will be installed on the project.
 3. System layout floor plans with complete device layout, point-to-point wiring connection between all components of the system, wire sizes and color coding.
 4. Coordinate with other division shop drawings and submittals. Identify interface points and indicate method of connection.
 5. Communications Rooms: Submit 1/2" = 1'-0" detail plans and wall elevations of each room showing actual size of equipment in place. Identify coordinating elements such as structural beams or mechanical systems. Submittals shall show coordination among all suppliers of equipment, including power components, fire alarm, racks, nurse call, public address, security, etc. Submit room layouts at same time as material submittals, and prior to installation of any equipment.
- E. The Contractor agrees:
1. Submittals and shop drawings processed by the Architect are not change orders.
 2. The purpose of submittals and shop drawings by the Contractor is to demonstrate to the Engineer that the Contractor understands the design concept.

**KOPACHUCK STATE PARK
DAY USE DEVELOPMENT**

3. Submittals demonstrate equipment and material Contractor intends to furnish and install and indicate detailing fabrication and installation methods Contractor intends to use.
 4. To accept all responsibility for assuring that all materials furnished under this Division of the specifications meet, in full, all requirements of the contract documents.
 5. To pay for Engineers review cost of submittal review beyond one resubmittal.
- F. The Engineer's review is only for general conformance with the design concept of the project and general compliance with the information given in the contract documents. Corrections or comments made during this review do not relieve contractor from compliance with the requirements of the drawings and specifications. Contractor is responsible for: Dimensions which shall be confirmed and correlated at the job site; fabrication process and techniques of construction; coordination of this work with that of all other trades; performing this work in a safe and satisfactory manner.
- G. Submittals and shop drawings are required per the submittals schedule at the end of this Section.
- 1.8 PROJECT CLOSE-OUT
- A. Coordinate with close-out provisions in Section 017700 – Closeout Procedures.
- B. Request For Final Punchlist
1. To request a final low voltage punch list, forward a letter to Owner, stating; "The communications work on this project is complete, all punch list items to date are complete, items a. - d. in the Punchlist Procure paragraph 1.8B2 in Section 270500 - Common Work Results For Communications are complete and the project is ready for final punch list observation."
 2. Project Punchlist Procedure: Perform the following procedures for project closeout of communications portions of work.
 - a. Color code junction boxes per Section 260533 - Raceways and Boxes For Electrical Systems.
 - b. Provide written warranty in O & M per the General Conditions of the Contract.
 - c. Furnish Record Drawings per this section.
 - d. Furnish O & M Manuals per this section.
- 1.9 COMMUNICATIONS EQUIPMENT OPERATION AND MAINTENANCE (O&M) MANUALS
- A. Provide O&M manuals required in Section 017700 – Closeout Procedures plus one manual for Stantec for all equipment furnished under Division 27 - Communications of the specifications. Submit a preliminary copy, complete except for the bound cover, 60 days prior to completion of the project for checking and review. Deliver final bound corrected copies as noted in Division 01 - General Requirements plus a copy to Stantec 20 days prior to scheduled instruction periods. Obtain a receipt for the manuals and forward a copy of the receipt to the Engineer with the Job Completion Form.

**KOPACHUCK STATE PARK
DAY USE DEVELOPMENT**

- B. The information included must be the exact equipment installed. Where sheets show the equipment installed and other equipment, the installed equipment shall be neatly and clearly identified on such sheets.

- C. These O&M manuals shall contain all the information needed to operate and maintain all systems and equipment provided in the project. Present and arrange information in a logical manner for efficient use by the Owner's operating personnel. The information provided shall include but not be limited to the following:
 - 1. Equipment manufacturer, make, model number, size, nameplate data, etc.
 - 2. Description of system configuration and operation including component identification and interrelations. A master control schematic drawings(s) may be required for this purpose.
 - 3. Dimensional and performance data for specific unit provided as appropriate.
 - 4. Manufacturer's recommended operation instructions.
 - 5. Complete parts list including reordering information, recommended spares and anticipated useful life (if appropriate). Parts lists shall give full ordering information assigned by the original parts manufacturer. Relabeled and/or renumbered parts information as reassigned by equipment supplier not acceptable.
 - 6. Shop drawings.
 - 7. Wiring diagrams.
 - 8. Signal equipment submittals shall contain step-by-step circuit description information designed to acquaint maintenance personnel with equipment operation in each mode of operation.
 - 9. A complete list of local (nearest) manufacturer representative and distributor contacts for each type of equipment and manufacturer. Include name, company, address, phone, fax, e-mail address, and web site.
 - 10. Cable test reports.

- D. Furnish complete wiring diagrams for each system for the specific system installed under the contract. "Typical" line diagrams will not be acceptable unless revised to indicate the exact field installation.

- E. Group the information contained in the manuals in an orderly arrangement by specification index. Provide a typewritten index and divider sheets between categories with identifying tabs. Bind the completed manuals with hard board covers not exceeding 5" thick. (Provide two or more volumes if required.) Signal and communication systems shall be in separate volumes. Imprint the covers with the name of the job, Owner, Architect, Engineer, Contractor and year of completion. Imprint the back edge with the name of the job, Owner and year of completion. Hard board covers and literature contained may be held together with screw post binding.

1.10 AS-BUILT DRAWINGS

- A. Continually record the actual low voltage system(s) installation on a set of prints or PDFs kept readily available at the project during construction. These prints shall be used for this purpose alone.

**KOPACHUCK STATE PARK
DAY USE DEVELOPMENT**

1. Mark record prints electronically or with red erasable pencil. Mark the set to show the actual installation where the installation varies substantially from the work as originally shown.
 2. Accurately locate with exact dimensions all underground and underslab raceways and stub-outs.
 3. Note changes of directions and locations, by dimensions and elevations, as utilities are actually installed.
 4. Include addenda items and revisions made during construction.
 5. Erase conditions not constructed or "X-out" and annotate "not constructed" to clearly convey the actual "as constructed" condition.
 6. Organize as-built drawings sheets in manageable sets, bind and print suitable titles, dates and other identification on the cover of each set.
- B. Transmit the as-built drawing set to the Architect at the completion of the work. Final payment to the contractor will not be authorized until these prints have been submitted to and accepted by the Architect.
- C. Transfer the changes marked up on the record prints into AutoCAD 2014 (or higher) at the completion of the work. Provide two (2) sets of prints, one set of fixed line reproducible drawings and one set of AutoCAD drawing files. Transmit drawings, CAD files and the as-built drawing mark-ups to the Architect. Final payment to the contractor will not be authorized until these documents have been submitted to and accepted by the Architect.

1.11 FINAL ACCEPTANCE REQUEST

- A. Submit to the Architect, with a copy to the Stantec Engineer, a Stantec Job Completion Form (form attached in this section) properly filled out prior to the time final acceptance of the work is requested.

1.12 ABBREVIATIONS AND DEFINITIONS

- A. When the following abbreviations and definitions are used in relation to the work for Division 27 they shall have the following meanings:

<u>Item</u>	<u>Meaning</u>
AHJ	Authority Having Jurisdiction.
BICSI	Building Industry Consulting Service International
Boxes	Outlet, Junction or Pull Boxes.
Code	All applicable codes currently enforced at project location.
Compression	Compressed using a leverage powered (hydraulic or equivalent) crimping tool.
Connection	All materials and labor required for equipment to be fully operational.
Exterior Location	Outside of or penetrating the outer surfaces of the building weather protective membrane.

**KOPACHUCK STATE PARK
DAY USE DEVELOPMENT**

Fully Operational	Tested, approved, and operating to the satisfaction of the AHJ, manufacturer and contract documents.
Install	To enter or attach permanently into the project and make fully operational.
Mfr.	Manufacturer.
NEC	National Electrical Code, National Fire Protection Association, Publication #70.
Noted	Shown or specified in the Contract Documents.
Provide	Furnish and install.
Required	As required by code, AHJ, contract documents, or manufacturer for the particular installation to be fully operational.
Shown	As indicated on the drawings or details.
Wiring	Raceway, conductors and connections.
Accepted/Acceptable	Work or materials conforming with the intent of the project, and in general, conforming to the pertinent information in the Construction Documents.
Approved/Approval	The written approval of the Engineer.
Accessible/Easy access	Access attained without requiring extensive removal of other materials to gain access.
Accessible Ceiling	Acoustical tile hanging ceilings (“Hard-lid” ceilings concealed spine or sheetrock/gypsum ceilings, even when provided with access panels, are not considered an Accessible Ceiling.)
Agreement Communications Infrastructure System:	The contractual agreement between the Owner and the Contractor. A communications Cabling System combined with a Communications Raceway System.
Concealed	Hidden from sight in interstitial building spaces, chases, furred spaces, shafts, crawl spaces, etc.
Construction Documents	Collective term for the entire set of bound or unbound material describing the construction and services required, including all Drawings, Specifications, addenda issued prior to execution of the contract, and modifications issued after Execution of the Contract (such as change orders, construction change directives, supplemental instructions, etc.).
The Contractor Drawings	The party responsible for providing the system(s) as indicated herein. The graphic and pictorial portions of the Contract Documents, wherever located and whenever issued, showing the design, location and dimensions of the Work, generally including (but not limited to) plans, elevations, sections, details, schedules and/or diagrams.
Engineer/Consultant	The party responsible for producing the communications system(s) Construction Documents.
Exposed	Not concealed (see above) and not installed underground.
Final Completion	The date when the Engineer confirms in writing that the Contractor has completed the work in accordance with the Construction Documents, including completion of all punch list items, cleanup work and delivery of all required guarantees, warranties, licenses, releases and other required deliverables.
Furnish	To purchase, supply, and deliver to the project materials in new and operable condition, ready for installation.
Governing	

**KOPACHUCK STATE PARK
DAY USE DEVELOPMENT**

Requirements	Collective term for regulations, laws, ordinances, codes, rules, standards, requirements, and guidelines that govern the installation and inspection of the work defined in the Contract Documents. See “Part 1 – General, 1.8 Governing Requirements” herein.
Governing Authorities	Entities or their representatives charged with formation and/or enforcement of Governing Requirements, such as the Authority Having Jurisdiction (AHJ).
Install Inside Plant (ISP)	To place in final position in fully operable, tested condition. Infrastructure within a building; includes raceways, cabling, termination components and racks/cabinets.
Or Equal, Or Equivalent	Materials approved for use by the Engineer and which are dimensionally suitable and operationally identical to the specified item.
Outside Plant (OSP)	Infrastructure exterior to a building.
Owner	The Owner and the Owner's designated representative(s).
The Project	The total construction of which the Work performed under the Contract Documents may be the whole or a part, and which may include construction by the Owner and/or separate contractors.
RCDD	Registered Communications Distribution Designer
Substantial Completion	The date when all work required by the Construction Documents shall be complete (subject to the final punch list to be prepared by the Engineer) and on which the applicable jurisdictional authorities have issued a temporary certification of occupancy.
Section	An individual section of the Specifications.
Shown on Drawings	Noted, indicated, scheduled, detailed, or any other written reference made on the Drawings.
Specifications	The portion of the Contract Documents consisting of the written requirements for materials, equipment, construction systems, standards and workmanship for the Work and performance of related services.
Specification Section(s)	One or more sections of the Specifications.
Structured Cabling System (SCS)	Alternative term for Communications Cabling System
The Work	The construction and services required by the Contract Documents, whether completed or partially completed, and all other labor, materials, equipment and services provided or to be provided by the Contractor to fulfill the Contractor’s obligations. The Work may constitute the whole or a part of the Project.

PART 2 - PRODUCTS

2.1 GENERAL

- A. All materials and equipment installed shall have been tested and listed by Underwriters Laboratories or other approved testing organization and shall be so labeled unless otherwise permitted by the Authority Having Jurisdiction (Inspector).

**KOPACHUCK STATE PARK
DAY USE DEVELOPMENT**

- B. All materials to be new, free from defects and not less than quality herein specified. Materials shall be designated to insure satisfactory operation and operational life in the environmental conditions which will prevail where they are being installed.
- C. Each type of materials furnished shall be of the same make, be standard products of manufacturers regularly engaged in production of such materials and be the manufacturer's latest standard design.
- D. All materials, equipment and systems furnished that include provisions for storing, displaying, reporting, interfacing, inputting, or functioning using date specific information shall perform properly in all respects regardless of the century. Any interface to other new or existing materials, equipment or systems shall function properly and shall be century compliant, both in regard to information sent and received.
- E. All materials shall be PCB-free.
- F. All paint to be low-VOC.

2.2 SUBSTITUTION OF MATERIALS

- A. No Substitute: Where a specified product is indicated "no substitute", it is the intent of this specification to require new materials to be compatible with the existing installation or as specifically requested by the owner. To this end certain materials and systems no substitution will be allowed.
- B. Prior to Bid Opening: Acceptance of products other than those specified will be issued by addendum to the bid documents only after the following requirements are met and the proposed listed material is determined to meet or exceed the requirements:
 - 1. Requests for listing to be original material, clearly indicating the product fully complies with contract documents and be neatly marked with yellow felt tip marker to clearly define and describe the product for which listing is requested.
 - 2. Samples shall be submitted if requested.
 - 3. Requests shall be received 10 days prior to bid opening.
 - 4. Requests containing insufficient information to confirm compliance with contract documents will not be considered.
- C. After Award of Contract: Substitution of products will be considered after award of contract only under the following conditions:
 - 1. The Contractor shall have placed orders for specified materials promptly after contract is awarded and the specified products cannot be delivered to the project to meet the Owner's construction schedule.
 - 2. The reason for the unavailability is beyond the Contractor's control, i.e., due to strikes, bankruptcy, discontinuance of manufacturer, acts of God.
 - 3. The specified product is no longer manufactured.
 - 4. There is compelling economic advantage to the Owner.
 - 5. There is compelling sustainable or environmental advantage.

**KOPACHUCK STATE PARK
DAY USE DEVELOPMENT**

- D. In all cases, should a substituted material result in requiring system or building modifications; the Contractor alone shall pay all costs to provide these modifications including all costs to the Engineer and Architect for redesign, and updating of as-builts drawings required to accommodate the required modifications.

PART 3 - EXECUTION

3.1 PRODUCT DELIVERY, STORAGE AND HANDLING

- A. Deliver, store, and handle products according to the manufacturer's recommendations, using means and methods that will prevent damage, deterioration, and loss, including theft. Handle all equipment carefully to prevent damage, breakage, denting, and scoring of finishes. Do not install damaged equipment.
- B. Store products subject to damage by the elements above ground, undercover in a weather tight enclosure, with ventilation adequate to prevent condensation. Maintain temperature and humidity within range required by manufacturer's instruction.

3.2 CUTTING BUILDING CONSTRUCTION

- A. Obtain permission from the Architect and coordinate with other trades prior to cutting. Locate cuttings so they will not weaken structural components. Cut carefully and only the minimum amount necessary. Cut concrete with diamond core drills or concrete saws except where space limitations prevent the use of such tools.
- B. All construction materials damaged or cut into during the installation of this work must be repaired or replaced with materials of like kind and quality as original materials by skilled labor experienced in that particular building trade.

3.3 PAINTING

- A. Items furnished under this Division that are scratched or marred in shipment or installation shall be refinished with touchup paint selected to match installed equipment finish.

3.4 EQUIPMENT CONNECTION

- A. For equipment furnished under this or other Divisions of the specifications, or by owner, provide complete all connections necessary to serve such equipment and provide required control connections to all equipment so that the equipment is fully operational upon completion of the project.
- B. Investigate existing equipment to be relocated and provide new connections as required.
- C. Obtain rough-in requirements for equipment furnished under other divisions of this specification prior to roughing-in. Review shop drawings and submittals of other Divisions to determine requirements.

**KOPACHUCK STATE PARK
DAY USE DEVELOPMENT**

3.5 CLEAN UP

- A. Contractor shall continually remove debris, cuttings, crates, cartons, etc., created by this work. Such clean up shall be done daily and at sufficient frequency to eliminate hazard to the public, other workers, the building or the Owner's employees. Before acceptance of the installation, Contractor shall carefully clean cabinets, panels, lighting fixtures, wiring devices, cover plates, etc., to remove dirt, cuttings, paint, plaster, mortar, concrete, etc. Blemishes to finished surfaces of apparatus shall be removed and new finish equal to the original applied.
 - 1. Wipe surfaces of low voltage equipment. Remove excess lubrication, paint and mortar droppings, and other foreign substances.
 - 2. Equipment installed prior to final clean-up shall be cleaned by the contractor. Jacks and patch panels that have construction dirt and dust shall be cleaned to like new condition.

- B. Materials recycling and salvage:
 - 1. Recycle all scrap metal.
 - 2. Salvage operable equipment removed from site and deliver to local resale organization.

3.6 TESTING AND DEMONSTRATION

- A. Demonstrate that all equipment operates as specified and in accordance with manufacturer's instructions. Perform tests in the presence of the Architect, Owner or Engineer. Provide all instruments, manufacturer's operating instructions and personnel required to conduct the tests. Repair or replace any equipment that fails to operate as specified and or in accordance with manufacturer's requirements.

END OF SECTION 270500

**KOPACHUCK STATE PARK
DAY USE DEVELOPMENT**

SECTION 270526 - GROUNDING AND BONDING FOR COMMUNICATIONS SYSTEMS

PART 1 - GENERAL

1.1 RELATED DOCUMENTS

- A. Drawings and general provisions of the Contract, including General Conditions, Division 01 Specification Sections, and Section 270500 – Common Work Results for Communications apply to this Section.

1.2 SUMMARY

- A. Section Includes:
 - 1. Grounding conductors.
 - 2. Grounding connectors.
 - 3. Grounding busbars.
 - 4. Grounding rods.
 - 5. Grounding labeling.

1.3 DEFINITIONS

- A. BCT: Bonding conductor for telecommunications.
- B. EMT: Electrical metallic tubing.
- C. PBB: Primary bonding busbar / Telecommunications grounding busbar.
- D. SBB: Secondary bonding busbar / Telecommunications main grounding busbar.

1.4 ACTION SUBMITTALS

- A. Product Data: For each type of product.
- B. Shop Drawings: For communications equipment room signal reference grid. Include plans, elevations, sections, details, and attachments to other work.

1.5 INFORMATIONAL SUBMITTALS

- A. As-Built Data: Plans showing as-built locations of grounding and bonding infrastructure, including the following:
 - 1. Ground rods.
 - 2. Ground and roof rings.
 - 3. BCT, PBB, SBBs, and routing of their bonding conductors.

**KOPACHUCK STATE PARK
DAY USE DEVELOPMENT**

- B. Qualification Data: For installer, installation supervisor, and field inspector.
- C. Qualification Data: For testing agency and testing agency's field supervisor.
- D. Field quality-control reports.

1.6 CLOSEOUT SUBMITTALS

- A. Operation and Maintenance Data: For grounding to include in emergency, operation, and maintenance manuals.
 - 1. In addition to items specified in Section 017700 – Closeout Procedures, include the following:
 - a. Result of the ground-resistance test, measured at the point of BCT connection.
 - b. Result of the bonding-resistance test at each SBB and its nearest grounding electrode.

1.7 QUALITY ASSURANCE

- A. Installer Qualifications: Cabling Installer must have personnel certified by BICSI on staff.
 - 1. Installation Supervision: Installation shall be under the direct supervision of ITS Technician who shall be present at all times when Work of this Section is performed at Project site.

PART 2 - PRODUCTS

2.1 SYSTEM COMPONENTS

- A. Comply with ANSI/TIA-607-C.

2.2 CONDUCTORS

- A. Manufacturers: Subject to compliance with requirements, provide products by one of the following:
 - 1. Harger Lightning and Grounding.
 - 2. Panduit Corp.
 - 3. Tyco Electronics Corp.
- B. Comply with UL 486A-486B.

**KOPACHUCK STATE PARK
DAY USE DEVELOPMENT**

- C. Insulated Conductors: Stranded copper wire, green or green with yellow stripe insulation, insulated for 600 V, and complying with UL 83.
1. Ground wire for custom-length equipment ground jumpers shall be No. 6 AWG, 19-strand, UL-listed, Type THHN wire.
 2. Cable Tray Equipment Grounding Wire: No. 6 AWG.
- D. Bare Copper Conductors:
1. Solid Conductors: ASTM B 3.
 2. Stranded Conductors: ASTM B 8.
 3. Tinned Conductors: ASTM B 33.
 4. Bonding Cable: 28 kcmils, 14 strands of No. 17 AWG conductor, and 1/4 inch in diameter.
 5. Bonding Conductor: No. 4 or No. 6 AWG, stranded conductor.
 6. Bonding Jumper: Tinned-copper tape, braided conductors terminated with two-hole copper ferrules; 1-5/8 inches wide and 1/16 inch thick.
- E. Conductor Sizing Table:

Table 1 –TBB conductor size vs length

TBB/GE linear length m (ft)	TBB/GE size (AWG)
less than 4 (13)	6
4 – 6 (14 – 20)	4
6 – 8 (21 – 26)	3
8 – 10 (27 – 33)	2
10 – 13 (34 – 41)	1
13 – 16 (42 – 52)	1/0
16 – 20 (53 – 66)	2/0
20 – 26 (67 – 84)	3/0
26 – 32 (85 – 105)	4/0
32 – 38 (106 – 125)	250 kcmil
38 – 46 (126 – 150)	300 kcmil
46 – 53 (151 – 175)	350 kcmil
53 – 76 (176 – 250)	500 kcmil
76 – 91 (251 – 300)	600 kcmil
Greater than 91 (301)	750 kcmil

2.3 CONNECTORS

- A. Irreversible connectors listed for the purpose. Listed by an NRTL as complying with NFPA 70 for specific types, sizes, and combinations of conductors and other items connected. Comply with UL 486A-486B.

**KOPACHUCK STATE PARK
DAY USE DEVELOPMENT**

- B. Manufacturers: Subject to compliance with requirements, provide products by one of the following:
1. Burndy; Part of Hubbell Electrical Systems.
 2. Chatsworth Products, Inc.
 3. Harger Lightning and Grounding.
 4. Panduit Corp.
 5. Tyco Electronics Corp.
- C. Compression Wire Connectors: Crimp-and-compress connectors that bond to the conductor when the connector is compressed around the conductor. Comply with UL 467.
1. Electroplated tinned copper, C and H shaped.
- D. Busbar Connectors: Cast silicon bronze, solderless compression-type, mechanical connector; with a long barrel and two holes spaced on 5/8- or 1-inch centers for a two-bolt connection to the busbar.
- E. Welded Connectors: Exothermic-welding kits of types recommended by kit manufacturer for materials being joined and installation conditions.

2.4 GROUNDING BUSBARS

- A. Manufacturers: Subject to compliance with requirements, provide products by one of the following:
1. Chatsworth Products, Inc.
 2. Harger Lightning and Grounding.
 3. Panduit Corp.
- B. PBB: Predrilled, wall-mounted, rectangular bars of hard-drawn solid copper, in cross section. The busbar shall be NRTL listed for use as PBB and shall comply with ANSI/TIA-607-C.
1. Predrilling shall be with holes for use with lugs specified in this Section.
 2. Mounting Hardware: Stand-off brackets that provide a 4-inch clearance.
 3. Stand-off insulators for mounting shall be Lexan or PVC. Comply with UL 891 for use in 600-V switchboards, impulse tested at 5000 V.
- C. SBB: Predrilled rectangular bars of hard-drawn solid copper, **1/4 by 2 inches by 10 inches** in cross section. The busbar shall be for wall mounting, shall be NRTL listed as complying with UL 467, and shall comply with ANSI/TIA-607-C.
1. Predrilling shall be with holes for use with lugs specified in this Section.
 2. Mounting Hardware: Stand-off brackets that provide at least a 2-inch clearance to access the rear of the busbar. Brackets and bolts shall be stainless steel.
 3. Stand-off insulators for mounting shall be Lexan or PVC. Comply with UL 891 for use in 600-V switchboards, impulse tested at 5000 V.

**KOPACHUCK STATE PARK
DAY USE DEVELOPMENT**

- D. Rack and Cabinet Grounding Busbars: Rectangular bars of hard-drawn solid copper, accepting conductors ranging from No. 14 to No. 2/0 AWG, NRTL listed as complying with UL 467, and complying with ANSI/TIA-607-C. Predrilling shall be with holes for use with lugs specified in this Section.
1. Cabinet-Mounted Busbar: Terminal block, with stainless-steel or copper-plated hardware for attachment to the cabinet.
 2. Rack-Mounted Horizontal Busbar: Designed for mounting in 19-inch equipment racks. Include a copper splice bar for transitioning to an adjoining rack, and stainless-steel or copper-plated hardware for attachment to the rack.
 3. Rack-Mounted Vertical Busbar: 36 inches with stainless-steel or copper-plated hardware for attachment to the rack.

2.5 GROUND RODS

- A. Manufacturers: Subject to compliance with requirements, provide products by one of the following:
1. Harger Lightning and Grounding.
 2. Tyco Electronics Corp.
- B. Ground Rods: steel, 5/8 by 96 inches in diameter.

2.6 LABELING

- A. Manufacturers: Subject to compliance with requirements, provide products by one of the following:
1. Brother International Corporation.
 2. HellermannTyton.
 3. Panduit Corp.
 4. SYSTIMAX, A Commscope Company
- B. Comply with TIA-606-B and UL 969 for a system of labeling materials, including label stocks, laminating adhesives, and inks used by label printers.
- C. Adhesive Film Label with Clear Protective Overlay: Machine printed, in black, by thermal transfer or equivalent process. Minimum letter height shall be 3/8 inch. Overlay shall provide a weatherproof and UV-resistant seal for label.

PART 3 - EXECUTION

3.1 EXAMINATION

- A. Examine the ac grounding electrode system and equipment grounding for compliance with requirements for maximum ground-resistance level and other conditions affecting performance of grounding and bonding of the electrical system.

**KOPACHUCK STATE PARK
DAY USE DEVELOPMENT**

- B. Inspect the test results of the ac grounding system measured at the point of BCT connection.
- C. Prepare written report, endorsed by Installer, listing conditions detrimental to performance of the Work.
- D. Proceed with connection of the BCT only after unsatisfactory conditions have been corrected.

3.2 INSTALLATION

- A. Bonding shall include the ac utility power service entrance, the communications cable entrance, and the grounding electrode system. The bonding of these elements shall form a loop so that each element is connected to at least two others.
- B. Comply with NECA 1.
- C. Comply with ANSI/TIA-607-C.

3.3 APPLICATION

- A. Conductors: Install solid conductor for No. 8 AWG and smaller and stranded conductors for No. 6 AWG and larger unless otherwise indicated.
 - 1. The bonding conductors between the SBB and structural steel of steel-frame buildings shall not be smaller than No. 6 AWG.
 - 2. The bonding conductors between the PBB and structural steel of steel-frame buildings shall not be smaller than No. 6 AWG.
- B. Underground Grounding Conductors: Install bare copper conductor, No. 2 AWG minimum.
- C. Conductor Terminations and Connections:
 - 1. Pipe and Equipment Grounding Conductor Terminations: Bolted connectors.
 - 2. Underground Connections: Welded connectors except at test wells and as otherwise indicated.
 - 3. Connections to Ground Rods at Test Wells: Bolted connectors.
 - 4. Connections to Structural Steel: Welded connectors.
- D. Conductor Support:
 - 1. Secure grounding and bonding conductors at intervals of not less than 36 inches

**KOPACHUCK STATE PARK
DAY USE DEVELOPMENT**

E. Grounding and Bonding Conductors:

1. Install in the straightest and shortest route between the origination and termination point, and no longer than required. The bend radius shall not be smaller than eight times the diameter of the conductor. No one bend may exceed 90 degrees.
2. Install without splices.
3. Support at not more than 36-inch intervals.
4. Install grounding and bonding conductors in 3/4-inch PVC conduit until conduit enters a telecommunications room. The grounding and bonding conductor pathway through a plenum shall be in EMT. Conductors shall not be installed in EMT unless otherwise indicated.

3.4 GROUNDING ELECTRODE SYSTEM

- A. The BCT between the PBB and the ac service equipment ground shall be sized according to the distance between the two devices and according to the Conductor Sizing Table shown above in 2.2.F.

3.5 GROUNDING BUSBARS

- A. Indicate locations of grounding busbars on Drawings. Install busbars horizontally, on insulated spacers 2 inches minimum from wall, 18 inches above finished floor unless otherwise indicated.

3.6 CONNECTIONS

- A. Bond metallic equipment in a telecommunications equipment room to the grounding busbar in that room, using equipment grounding conductors not smaller than No. 6 AWG.
- B. Stacking of conductors under a single bolt is not permitted when connecting to busbars.
- C. Assemble the wire connector to the conductor, complying with manufacturer's written instructions and as follows:
1. Use crimping tool and the die specific to the connector.
 2. Pretwist the conductor.
 3. Apply an antioxidant compound to all bolted and compression connections.
- D. Primary Protector: Bond to the PBB with insulated bonding conductor.
- E. Interconnections: Interconnect all SBBs with the PBB with the telecommunications backbone conductor. If more than one PBB is installed, interconnect PBBs using the grounding equalizer conductor. The telecommunications backbone conductor and grounding equalizer conductor shall be sized according to the distance between the two devices and according to the Conductor Sizing Table shown above in 2.2.F.
- F. Telecommunications Enclosures and Equipment Racks: Bond metallic components of enclosures to the telecommunications bonding and grounding system. Install vertically mounted rack grounding busbar unless the enclosure and rack are manufactured with the busbar. Bond the equipment grounding busbar to the SBB No. 2 AWG bonding conductors.

KOPACHUCK STATE PARK DAY USE DEVELOPMENT

- G. Structural Steel: Where the structural steel of a steel frame building is readily accessible within the room or space, bond each SBB and PBB to the vertical steel of the building frame.
- H. Electrical Power Panelboards: Where an electrical panelboard for telecommunications equipment is located in the same room or space, bond each SBB to the ground bar of the panelboard.
- I. Shielded Cable: Bond the shield of shielded cable to the SBB in communications rooms and spaces. Comply with TIA/EIA-568-C when grounding screened, balanced, twisted-pair cables.
- J. Rack- and Cabinet-Mounted Equipment: Bond powered equipment chassis to the cabinet or rack grounding bar. Power connection shall comply with NFPA 70; the equipment grounding conductor in the power cord of cord- and plug-connected equipment shall be considered as a supplement to bonding requirements in this Section.

3.7 IDENTIFICATION

- A. Labels shall be preprinted or computer-printed type.
 - 1. Label PBB(s) with "fs-PBB," where "fs" is the telecommunications space identifier for the space containing the PBB.
 - 2. Label SBB(s) with "fs-SBB," where "fs" is the telecommunications space identifier for the space containing the SBB.
 - 3. Label the BCT and each telecommunications backbone conductor at its attachment point: "WARNING! TELECOMMUNICATIONS BONDING CONDUCTOR. DO NOT REMOVE OR DISCONNECT!"

3.8 FIELD QUALITY CONTROL

- A. Testing Agency: Engage a qualified testing agency to perform tests and inspections.
- B. Perform tests and inspections.
- C. Tests and Inspections:
 - 1. Inspect physical and mechanical condition. Verify tightness of accessible, bolted, electrical connections with a calibrated torque wrench according to manufacturer's written instructions.
 - 2. Test the bonding connections of the system using an ac earth ground-resistance tester, taking two-point bonding measurements in each telecommunications equipment room containing a PBB and a SBB and using the process recommended by BICSI TDMM. Conduct tests with the facility in operation.
 - a. Measure the resistance between the busbar and the nearest available grounding electrode. The maximum acceptable value of this bonding resistance is 100 milliohms.

**KOPACHUCK STATE PARK
DAY USE DEVELOPMENT**

3. Test for ground loop currents using a digital clamp-on ammeter, with a full-scale of not more than 10 A, displaying current in increments of 0.01 A at an accuracy of plus/minus 2.0 percent.
 - a. With the grounding infrastructure completed and the communications system electronics operating, measure the current in every conductor connected to the PBB. Maximum acceptable ac current level is 1 A.
- D. Excessive Ground Resistance: If resistance to ground at the BCT exceeds 5 ohms, notify Architect promptly and include recommendations to reduce ground resistance.
- E. Grounding system will be considered defective if it does not pass tests and inspections.
- F. Prepare test and inspection reports.

END OF SECTION 270526

**KOPACHUCK STATE PARK
DAY USE DEVELOPMENT**

SECTION 270529 - HANGERS AND SUPPORTS FOR COMMUNICATIONS SYSTEMS

PART 1 - GENERAL

1.1 RELATED DOCUMENTS

- A. Drawings and general provisions of the Contract, including General Conditions and Division 1 Specification Sections, apply to this Section.
- B. Section 270500 - Common Work Results for Communications

1.2 SUMMARY

- A. Section includes discrete J-hooks, slings and related accessories for supporting communications and other low voltage cables above accessible ceilings and below accessible raised floor systems.

1.3 REFERENCES

- A. As indicated in Section 270500 – Common Work Results for Communications.

1.4 SUBMITTALS

- A. Provide submittal information in accordance with Section 270500 - Common Work Results for Communications and supplementary requirements described in this specification.
- B. Product Data: Provide the following:
 - 1. Product data on all cable support devices and accessories. Indicate materials, finishes, load ratings, dimensions, listings, approvals and attachment methods.
- C. Shop Drawings: For projects where the low voltage systems cable pathways are not shown on the drawings, they are to be contractor designed per Part 3. The contractor shall prepare and submit proposed main pathway (20 cables or more), layout drawings for review and approval by the Owner's representative prior to installing supports. Shop drawings shall:
 - 1. Indicate pathways on plan view showing pathway coordination with mechanical components, lighting components, sprinkler head components, plumbing components and electrical components
 - 2. Include elevations and sections to indicate space allocations and coordination with work of other trades
 - 3. Include details to describe the different support configurations, accessories, attaching means and cable groupings

**KOPACHUCK STATE PARK
DAY USE DEVELOPMENT**

- D. Closeout Submittals – In accordance with section 270500.

1.5 QUALITY ASSURANCE

- A. Hangers, supports, and accessories shall be listed to Underwriter's Laboratories, Inc Standard 2239.
- B. Pre-Installation Meetings: Contractor shall set up a pre-installation meeting to discuss communication and other low voltage cable support layout work and installation guidelines. Contractor shall organize meeting a minimum of 30 days prior to initiating hangers and support installation work. Attendees shall include general contractor, cable tray contractor, cable contractor(s), mechanical contractor, sprinkler contractor low voltage system vendors, Architect and Engineer. Purpose of meeting shall be to coordinate work between the parties to have a consistent layout for all communications and low voltage system cables, minimize interferences and to make cable system accessibility for future Owner modifications and maintenance high priority issue for all installers.

1.6 COORDINATION

- A. Coordinate as required in section 270500- Common Work Results for Communications.
- B. Examine drawings and existing conditions above ceilings and include additional supports in bid price to avoid ducts, pipes, conduits, etc. Installation in existing ceilings if very difficult. Include extra labor time involved in bid price.

PART 2 - PRODUCTS

2.1 WIDE BASE CABLE SUPPORTS

- A. J-hooks - Galvanized loop with integrated cable retainers, complies with TIA structured cabling system requirements, as indicated in section 270500 - Common Work Results for Communications.
- B. Accessories: Provide applicable accessories to independently support J-hooks from structure. This includes extender bracket for mounting multiple J-hooks on a single support, fasteners and clamps for connecting to wall, beams, rods, dedicated support wires and C and Z Purlins as required for specific construction.
- C. Manufacturer.
 - 1. nVent CADDY Cat HP J-hook series
 - 2. Chatsworth RapidTrak™ series
 - 3. Or approved equivalent.

**KOPACHUCK STATE PARK
DAY USE DEVELOPMENT**

2.2 SOFT CABLE SLING SUPPORTS

- A. Adjustable sling cable supports suitable for plenums. 4 inch or 6 inch diameter loop for (325) Cat6 4-pair UTP cables, (210) Cat6A 4-pair UTP cables or or inner duct.
- B. Accessories: Provide applicable accessories to independently support slings from structure. This includes fasteners and clamps for connecting to walls, beams, rods, ceiling tee bars, dedicated support wires and C and Z Purlins as required for specific construction.
- C. Material
 - 1. Construction: Polyethylene strands woven and laminated, reinforced seams, connected steel mounting and fastening hardware.
 - 2. Suitable for plenum location installation
- D. Manufacturer
 - 1. nVent CADDY Cat 425 series
 - 2. Or approved equivalent

PART 3 - EXECUTION

3.1 INSTALLATION

- A. Support all cables not supported in conduits and cable tray with J-hooks or slings. Space J-hooks or slings at a maximum of 48-inches apart and at each change of direction of the cables. Maintain maximum sag of 12-inches between supports.
- B. Install supports to route cables parallel and perpendicular to building lines. Hang cable supports from or 1/4" all thread rods, dedicated #8 galvanized ceiling drop wire or wall brackets connected directly to structure. Do not support from the ceiling grid, ceiling wire system, conduit or other trades work.
- C. Provide the appropriately sized J-hooks as required. Minimum 1" width and flared edges where cables enter and leave support. 2-inch diameter loop for (25) 4-pair UTP cables and 4-inch diameter loop for (50) 4-pair UTP cables.
- D. Provide multiple hooks at each hanger location as required by cable count and cable segregation requirements.
- E. Install cable bundles no closer than 5-inches in all directions from ballasted light fixtures.
- F. Where main pathways are indicated on the drawings, contractor shall follow indicated pathway as closely as possible according to field conditions. Pathway for smaller cable counts shall be laid out and documented on the as-built drawings by the contractor.

**KOPACHUCK STATE PARK
DAY USE DEVELOPMENT**

- G. Where specific main pathways are not indicated, the cable pathways for all communication systems shall be laid out by the contractor and coordinated with other disciplines and the systems designer.
- H. Do not tie wrap cables to the J-hooks. Provide cable retainers at each J-hook.
- I. Provide applicable accessories to independently support J-hooks from structure, including extender bracket for mounting multiple J hooks on a single support, fasteners and clamps for connecting to wall, beams, rods, dedicated support wires and C and Z Purlins as required for specific construction.
- J. At a minimum, brace multiple J-hook assemblies from structure with diagonal braces at each change of direction.
- K. Coordinate the allocation of ceiling space and the mounting elevations of various systems to allow maintenance and accessibility for future modifications. Cable supports shall be as close to the ceiling as possible while allowing ceiling tiles to be removed. Supports shall be located to avoid interference with maintenance access to other equipment.

END OF SECTION 270529

**KOPACHUCK STATE PARK
DAY USE DEVELOPMENT**

SECTION 270533 - CONDUITS AND BACKBOXES FOR COMMUNICATIONS SYSTEMS

PART 1 - GENERAL

1.1 RELATED DOCUMENTS

- A. Drawings and general provisions of the Contract, including General Conditions, Division 1 Specification Sections, and Section 270500 - Common Work Results for Communications apply to this Section.
- B. Other References:
 - 1. ANSI/TIA-569-D Commercial Building Standard for Telecommunications Pathways and Spaces.
 - 2. ASNI/TIA-607-C Commercial Building Grounding (Earthing) and Bonding Requirements for Telecommunications.

1.2 DESCRIPTION

- A. Provide raceway systems for the installation of the communications cabling. Installation shall include
 - 1. Raceways and Wireways (including sleeves, expansion fittings, penetrations and seals)
 - 2. Pull and Junction Boxes
 - 3. Outlet Boxes, mud rings, and cover plates

1.3 SUBMITTALS

- A. Provide submittal information in accordance with Section 270500 - Common Work Results for Communications and supplementary requirements described in this specification.
- B. Product Data: Provide the following:
 - 1. Product data on all cable support devices and accessories. Indicate materials, finishes, load ratings, dimensions, listings, approvals and attachment methods.
- C. Shop Drawings: For projects where the low voltage systems cable pathways are not shown on the drawings, they are to be contractor designed per Part 3. The contractor shall prepare and submit proposed main pathway (defined as 20 cables or more), layout drawings for review and approval by the Owner's representative prior to installing supports. Shop drawings shall:

**KOPACHUCK STATE PARK
DAY USE DEVELOPMENT**

1. Indicate pathways on plan view showing pathway coordination with mechanical components, lighting components, sprinkler head components, plumbing components and electrical components.
 2. Include elevations and sections to indicate space allocations and coordination with work of other trades
 3. Include details to describe the different support configurations, accessories, attaching means and cable groupings
- D. Closeout Submittals – In accordance with section 270500 - Common Work Results for Communications.

PART 2 - PRODUCTS

2.1 WALL OUTLETS

- A. Shall consist of a 4-11/16" square, 2-1/8" deep (minimum) box, with knockouts for 3/4", 1", and 1-1/4" conduits, as manufactured by Steel City, OZ/Gedney or equal.
- B. Shall consist of a 5" square, 2-7/8" deep box as manufactured by Randl Corporation.
- C. Surface wall outlets shall be 4" square, 2-3/4" deep (minimum) and shall match and be manufactured by the surface metal raceway manufacturer.

2.2 OUTLET DEVICE RING

- A. Provide single gang device ring.
- B. Provide two gang device ring.
- C. Device rings shall be by the same manufacturer as the outlet boxes.
- D. Coordinate device ring requirements with cable/outlet installer.

2.3 DEVICE PLATES

- A. Provide blank device cover plates for all un-cabled or "future" outlets.

2.4 PULL WIRE

- A. Shall be plastic having not less than 200-pound tensile strength.

**KOPACHUCK STATE PARK
DAY USE DEVELOPMENT**

PART 3 - EXECUTION

3.1 WALL OUTLETS IN WALLS WITH ACCESSIBLE CEILINGS

- A. Provide a minimum 1” individual conduit from each outlet location to an accessible ceiling space. Provide non-metallic conduit bushing prior to cable installation.

3.2 WALL OUTLETS IN WALLS WITH NON-ACCESSIBLE CEILINGS

- A. Provide an individual conduit from each outlet location to an accessible ceiling space. Provide non-metallic conduit bushing prior to cable installation.

3.3 CONDUIT SIZING TABLE

- A. Provide conduits for communications outlets sized as follows:

Wall Phones	<1">
Wall Outlets (except wall phones)	1"
Single Gang Floor Mounted Outlets/Boxes	1"
Multiple Gang Recessed Floor Outlets/Boxes	<1-1/4">
System Furniture - per every (2) workstations	1"
System Furniture - per every (3) workstations	1-1/4"
Surface Metal Raceway - per 12 ft of SMR	1-1/4"
Surface Metal Raceway - per 20 ft of SMR	1-1/2"

3.4 RACEWAYS

- A. Shall conform to specification as outlined in section 1.1, and Division 27 related sections - with the additional requirement that no length of run shall exceed 100 feet and shall not contain more than two 90-degree bends or the equivalent without a code size pull box sized per Pull Box Sizing table below. Provide pull boxes where necessary to comply with these requirements. Locate pull boxes in straight runs only, not as a replacement for an elbow.
- B. Conduits with an internal diameter of two inches or less shall have a bend radius at least 6 times the internal conduit diameter. Conduits greater than two inches shall have a bend radius at least 10 times the internal conduit diameter.
- C. Provide an insulated bushing on all conduits terminated in an enclosure, prior to cable installation.

Terminate conduits stubbed out above accessible ceiling space so that the conduit is parallel with the ceiling and provide an insulating bushing, prior to cable installation.

**KOPACHUCK STATE PARK
DAY USE DEVELOPMENT**

3.5 PULL BOXES

- A. Pull boxes shall be sized per the following table:

PULL BOX SIZING (inches)

Conduit Trade Size	Width	Length	Depth	Width increase for additional conduit
1	4	16	3	2
1-1/4	6	20	3	3
1-1/2	8	27	4	4
2	8	36	4	5
2-1/2	10	42	5	6
3	12	48	5	6
3-1/2	12	54	6	6
4	15	60	8	8

3.6 PULL CORDS

- A. Nylon type pull cords shall be included in all raceways over 10 feet long. Leave not less than 12 inches of slack at each end of the pull wire.

3.7 RACEWAY RISER SLEEVES

- A. Riser raceways to be installed through floors with tops 6 inches above each floor to give continuous cable riser capability. Provide Firestopping to meet requirements of Division 01.

END OF SECTION 270533

**KOPACHUCK STATE PARK
DAY USE DEVELOPMENT**

SECTION 271100 - COMMUNICATIONS EQUIPMENT ROOM FITTINGS

PART 1 - GENERAL

1.1 RELATED DOCUMENTS

- A. Drawings and general provisions of the Contract, including General Conditions and Division 01 Specification Sections, apply to this Section.
- B. Section 270500 - Common Work Results for Communications

1.2 SUMMARY

- A. Section Includes:
 - 1. Communications equipment and hardware mounting elements.
 - 2. Backboards.
 - 3. Communications equipment racks and cabinets.
 - 4. Grounding.

1.3 DEFINITIONS

- A. BICSI: Building Industry Consulting Service International.
- B. LAN: Local area network.
- C. RCDD: Registered Communications Distribution Designer.

1.4 SUBMITTALS

- A. Provide submittal information in accordance with Section 270500 - Common Work Results for Communications and supplementary requirements described in this specification.
- B. Product Data: For each type of product.
 - 1. Include construction details, material descriptions, dimensions of individual components and profiles, and finishes for equipment racks and cabinets.
 - 2. Include rated capacities, operating characteristics, electrical characteristics, and furnished specialties and accessories.

**KOPACHUCK STATE PARK
DAY USE DEVELOPMENT**

- C. Shop Drawings: For communications equipment room fittings. Include plans, elevations, sections, details, and attachments to other work.
 - 1. Detail equipment assemblies and indicate dimensions, weights, loads, required clearances, method of field assembly, components, and location and size of each field connection.
 - 2. Equipment Racks and Cabinets: Include workspace requirements and access for cable connections.
 - 3. Grounding: Indicate location of grounding bus bar and its mounting detail showing standoff insulators and wall mounting brackets.

- D. Closeout Submittals – In accordance with section 270500 - Common Work Results for Communications.

1.5 INFORMATIONAL SUBMITTALS

- A. Qualification Data: For qualified layout technician, installation supervisor, and field inspector.

1.6 QUALITY ASSURANCE

- A. Installer Qualifications: Cabling Installer must have personnel credentialed by BICSI on staff.
 - 1. Layout Responsibility: Preparation of Shop Drawings shall be under the direct supervision of RCDD.
 - 2. Field Inspector: Currently credentialed by BICSI as RCDD to perform the on-site inspection.

PART 2 - PRODUCTS

2.1 BACKBOARDS

- A. Backboards: Plywood, 3/4 by 48 by 96 inches. APA interior grade Douglas Fir A-C. Shall be fire retardant treated with flame spread rating not more than 25 when tested according to ASTM E84. Paint with light colored (white or off white) fire retardant paint. Comply with requirements for plywood backing panels specified in Section 061000 - Rough Carpentry.
 - 1. Backboards are to start +12" AFF and extend to a height of +9' AFF.
 - 2. Install backboards with 96-inch (2440-mm) dimension vertical. Butt adjacent sheets tightly and form smooth gap-free corners and joints.
 - 3. Painted with two (2) coat of paint. Painted finish in the room will be light colored to enhance room lighting.
 - 4. One (1) fire-retardant stamp is to be left unpainted on the bottom of each individual piece of fire-retardant plywood.

**KOPACHUCK STATE PARK
DAY USE DEVELOPMENT**

2.2 EQUIPMENT FRAMES

- A. Manufacturers: Subject to compliance with requirements, provide products by one of the following
1. ADC.
 2. Belden Inc.
 3. Chatsworth Products Inc.
 4. Cooper B-Line.
 5. Emerson Network Power Connectivity Solutions.
 6. Hubbell Premise Wiring.
 7. Leviton Commercial Networks Division.
 8. Middle Atlantic Products, Inc.
 9. Ortronics, Inc.
 10. Panduit Corp.
 11. Siemon Co. (The).
 12. Tyco Electronics Corporation; AMP Products.
- B. General Frame Requirements:
1. Distribution Frames: Freestanding and wall-mounting, modular-steel units designed for telecommunications terminal support and coordinated with dimensions of units to be supported.
 2. Module Dimension: Width compatible with EIA 310-D standard, 19-inch panel mounting.
 3. Finish: Manufacturer's standard, baked-polyester powder coat.
- C. Floor-Mounted Racks: Modular-type, steel or aluminum construction.
1. Vertical and horizontal cable management channels, top and bottom cable troughs, grounding lug, and a power strip.
 2. Baked-polyester powder coat finish.
- D. Modular Freestanding Cabinets:
1. Removable and lockable side panels.
 2. Hinged and lockable front and rear doors.
 3. Adjustable feet for leveling.
 4. Screened ventilation openings in the roof and rear door.
 5. Cable access provisions in the roof and base.
 6. Grounding bus bar.
 7. Rack mounted, 550-cfm fan with filter.
 8. Power strip.
 9. Baked-polyester powder coat finish.
 10. All cabinets keyed alike.

**KOPACHUCK STATE PARK
DAY USE DEVELOPMENT**

E. Modular Wall Cabinets:

1. Wall mounting.
2. Steel construction.
3. Treated to resist corrosion.
4. Lockable front[and rear] doors.
5. Louvered side panels.
6. Cable access provisions top and bottom.
7. Grounding lug.
8. Rack -mounted, 250-cfm fan.
9. Power strip.
10. All cabinets keyed alike.

F. Vertical Cable Management for Equipment Frames:

1. Metal, Single-sided inches deep storage capacity, with integral wire retaining fingers.
2. Baked-polyester powder coat finish.
3. Vertical cable management panels shall have front and rear channels, with covers.

G. Horizontal Cable Management for Equipment Frames:

1. Provide horizontal crossover cable manager at the top of each relay rack, with a minimum height of two rack units each.
2. Provide 1U horizontal cable manager below copper patch panels.]

2.3 LADDER RACKING/CABLE RUNWAY

A. Manufacturers: Subject to compliance with requirements, provide products by one of the following:

1. Chatsworth Products Inc.
2. Cooper B-Line.

B. Cable Runway Requirements: Rectangular steel tubing, 1-1/2"x3/8"x0.065". Cross members welded at 12" intervals.

**KOPACHUCK STATE PARK
DAY USE DEVELOPMENT**

C. Cable Runway Accessories: Provide cable runway with the following accessories:

1. Cable runway radius drop (“waterfalls”)
2. Butt-splice kit
3. Junction splice kit
4. 6” Channel Rack-to-runway mounting plate
5. Triangular support bracket
6. Wall angle support kit
7. End closing kit
8. End caps
9. Vertical wall bracket kit
10. Threaded drop radius
11. 6” Cable retaining posts

2.4 CABLE SPILLWAYS

A. Fits 4” diameter EMT conduits. Blue in color, made of fire-retardant ABS and stainless steel.

1. Manufacturer: Bejed, part number BJ-2049

2.5 PATHWAYS FOR FIRE RATED PENETRATIONS

A. Floor or wall fire rated pathway for communications cables.

1. Manufacturer: STI, Inc., part number EZ-Path Series 22.
2. Manufacturer: STI, Inc., part number EZ-Path Series 33.
3. Manufacturer: STI, Inc., part number EZ-Path Series 44+.
4. Manufacturer: Hilti, part number CP 653 2”.
5. Manufacturer: Hilti, part number CP 653 4”.

2.6 GROUNDING

A. Comply with ANSI/TIA -607-C, Commercial Building Grounding (Earthing) and Bonding Requirements for Telecommunications.

B. Comply with requirements in Section 260526 - Grounding and Bonding for Electrical Systems for grounding conductors and connectors.

C. Comply with requirements in Section 270526 - Grounding and Bonding for Communications Systems for grounding conductors and connectors.

2.7 LABELING

A. Comply with ANSI/TIA-606-B and UL 969 for a system of labeling materials, including label stocks, laminating adhesives, and inks used by label printers.

**KOPACHUCK STATE PARK
DAY USE DEVELOPMENT**

PART 3 - EXECUTION

3.1 ENTRANCE FACILITIES

- A. Contact telecommunications service provider and arrange for installation of demarcation point, protected entrance terminals, and a housing when so directed by service provider.

3.2 INSTALLATION

- A. Comply with NECA 1.
- B. Comply with BICSI TDMM for layout and installation of communications rooms.
- C. Bundle, lace, and train conductors and cables to terminal points without exceeding manufacturer's limitations on bending radii. Install lacing bars and distribution spools.
- D. Coordinate layout and installation of communications equipment with Owner's telecommunications and LAN equipment and service suppliers. Coordinate service entrance arrangement with local exchange carrier.
 - 1. Meet jointly with telecommunications and LAN equipment suppliers, local exchange carrier representatives, and Owner to exchange information and agree on details of equipment arrangements and installation interfaces.
 - 2. Record agreements reached in meetings and distribute them to other participants.
 - 3. Adjust arrangements and locations of distribution frames, cross-connects, and patch panels in equipment rooms to accommodate and optimize arrangement and space requirements of telephone switch and LAN equipment.
 - 4. Adjust arrangements and locations of equipment with distribution frames, cross-connects, and patch panels of cabling systems of other communications, electronic safety and security, and related systems that share space in the equipment room.
- E. Coordinate location of power raceways and receptacles with locations of communications equipment requiring electrical power to operate.

3.3 SLEEVE AND SLEEVE SEAL INSTALLATION FOR ELECTRICAL PENETRATIONS

- A. Install sleeves and sleeve seals at penetrations of exterior floor and wall assemblies.

3.4 GROUNDING

- A. Install grounding according to BICSI TDMM, "Grounding, Bonding, and Electrical Protection" Chapter.
- B. Comply with ANSI/TIA-607-C.
- C. Comply with Section 260526 - Grounding and Bonding for Electrical Systems.

**KOPACHUCK STATE PARK
DAY USE DEVELOPMENT**

- D. Comply with Section 270526 - Grounding and Bonding for Communications Systems.

3.5 IDENTIFICATION

- A. Identify system components, wiring, and cabling complying with ANSI/TIA-606-B. Comply with requirements in Section 260553 - Identification for Electrical Systems.
- B. Paint and label colors for equipment identification shall comply with ANSI/TIA-606-B for Class 2, Class 3, and Class 4 level of administration.
- C. Labels shall be preprinted or computer-printed type.

END OF SECTION 271100

**KOPACHUCK STATE PARK
DAY USE DEVELOPMENT**

SECTION 282300 – VIDEO SURVEILLANCE

PART 1 - GENERAL

1.1 RELATED DOCUMENTS

- A. Drawings and general provisions of the Contract, including General Conditions and Division 01 Specification Sections, apply to this Section.

1.2 SUMMARY

- A. This bidder design camera system must be able to record and archive up to 90 days of video for sixteen (16) cameras. The cameras must be able to record both day and night activity. There must not be any audio from the streaming cameras or recorded with the archived video. The streaming camera and archived video must be accessible over the local network and LTE network via IP address. The system must allow secure access to the live video and archive (the Owner will need to be able to view the streaming cameras as well as access, download, and view archived video). The cameras must be on separate network from Washington State Park. The system will need to be able to provide health monitoring, remote configuration, and troubleshooting.
- B. These specifications state the minimum acceptable characteristics for materials and equipment and define, in general terms, the configuration of the security system technologies to be installed and made fully operational by the selected Security System Contractor.
- C. Contractor shall have a total "turn-key" responsibility for ensuring the system is installed consistent with the manufacturer's specifications.
- D. Contractor shall be responsible to obtain and pay for any licenses, permits, and inspections that are required.
- E. Any aspect of these specifications, or future addendum, which appears to the Contractor to fall outside applicable codes or standards, shall immediately be brought to the attention of the Owner's Representative.
- F. The Contractor shall have sole responsibility to provide and for ensuring all components of the Network Recording System are fully functional and integrated in accordance with these specifications.
- G. Contractor shall be responsible to comply with all on-site construction requirements as dictated by the General Contractor to include any necessary safety training, Occupational Safety and Health Administration Standards, all National Consensus Standards, and all other federal, state and local safety codes and regulations along with the recommendations of the General Contractor.
- H. All components of this system shall be installed in a workmanlike manner in strict adherence to the manufacturer's specifications and applicable codes.

**KOPACHUCK STATE PARK
DAY USE DEVELOPMENT**

- I. Contractor shall be responsible for all "low voltage" communications for this system. All wire must be plenum rated where run through environmental air return spaces.
- J. Contractor shall be responsible for installing, connecting, configuring, and starting up all equipment.
- K. Contractor shall be responsible for the securing and storing of equipment during the installation process.

1.3 RELATED SECTIONS

- A. Related Sections include the following:

- 1. Section 260533 – Raceways and Boxes for Electrical Systems
- 2. Section 260540 – Electrical Site Work
- 3. Section 270500 – Common Work Results for Communications
- 4. Section 270533 – Conduits and Backboxes for Communications Cabling

1.4 SCOPE OF WORK

- A. Scope of work includes:

- 1. Provide, install and adjust the sixteen (16) cameras.
- 2. Responsible for terminating the sixteen (16) camera cable connections located at the NVR systems on the Park Welcome Center Station (Kopachuck State Park).
- 3. Provide, setup, and install one 16-channel NVR systems (located in Park Welcome Center Building).
- 4. Provide camera POE switch 24 ports (located in the Park Welcome Center Building).
- 5. Surge suppressor for each of the exterior cameras.
- 6. All cameras located in/on buildings or on light pole connected via Fiber network by Media convertor. Note: Power on the light poles (120VAC) to be provided at camera location by electrical contractor.
- 7. Install and focus the cameras, program the NVR systems, connect cameras to network and set up to program up to 90 days of data storage.
- 8. Provide a camera monitoring system (S-VIDIA VMS) with 34 inch monitor 21:9 ratio (located in Park Welcome Center Building).
- 9. Provide a software camera monitoring system (S-VIDIA MMVClient) for State Parks.
- 10. Provide documentation and training to State Park's IT Department.
- 11. Provide a warranty for 1-year hardware and labor.
- 12. Maintain and service the system upon request within a 24-hour period for 90 days after installation. Additional service contracts available.

1.5 SUBMITTALS

- A. Product data sheet for each type of product indicated. Include dimensions and data on features, performance, electrical characteristics, ratings, and finishes. Product sheets must clearly indicate item being provided.

**KOPACHUCK STATE PARK
DAY USE DEVELOPMENT**

- B. Operation and Maintenance Data: For cameras, power supplies, monitors, network video recorders to include operation, and maintenance manuals. Operation and Maintenance Data include the following:
1. Lists of spare parts and replacement components recommended to be stored at the site for ready access.
 2. Provide the name, address, telephone numbers, and email addresses of the contractor responsible for the installation and maintenance of the system. Include service and emergency service telephone numbers.
 3. Provide original software with manufacturer's label and license information.
 4. Provide complete bill of material of final equipment provided and installed to include model number, serial numbers, device MAC and IP address, and installed location shown on the as-built plan.

1.6 QUALITY ASSURANCE

- A. Electrical Components, Devices, and Accessories: Listed and labeled as defined in NFPA 70, by a qualified testing agency, and marked for intended location and application.
- B. Comply with NECA 1.
- C. Comply with NFPA 70.
- D. Contractor Qualifications: A certified technician who is an authorized service representative of the proposed equipment must be on the project site and shall have the requisite training and authorization from proposed equipment manufacturer to install and program the solution specified at the time of installation.

1.7 DELIVERY, STORAGE AND HANDLING

- A. Contractor shall be responsible for the complete delivery, storage and handling of all security related equipment:
1. Store in temperature and humidity-controlled environment in original manufacturer's sealed containers. Maintain ambient temperature between 50 and 85 degrees F (10 and 30 degrees C), and not more than 80 percent relative humidity, noncondensing.
 2. Open each container; verify contents against packing list; and file copy of the packing list, complete with container identification, for inclusion in operation and maintenance data.
 3. Mark packing list with the same designations assigned to materials and equipment for recording in the system.
 4. Save original manufacturer's containers and packing materials and deliver as directed under provisions covering extra materials.

**KOPACHUCK STATE PARK
DAY USE DEVELOPMENT**

1.8 WARRANTY

- A. Warranty: Manufacturer's standard from in which manufacturer agrees to repair or replace components of cameras, equipment related to camera operation, and control-station equipment that fail in materials or workmanship within specified warranty period. Contractor shall provide a complete parts, labor, installation and software warranty on all components associated with this purchase, for a period of one (1) year following acceptance of the entire system.
- B. Contractor shall honor any factory warranties on parts extending beyond one (1) year through the end of each such warranty period.
- C. Warranty period shall commence upon official acceptance by the Owner of the entire Network Recording System.
- D. During warranty period, the Contractor shall provide an advanced replacement of each component in need of replacement or repair at no additional cost to the Owner.
- E. During warranty period, the Contractor shall provide all available software and firmware upgrades, patches, hot-fixes, etc. to include all labor, at no additional cost to the owner.
- F. Security System components include all hardware, firmware, devices, and other materials and labor unless specifically excluded in this document.
- G. Warranty response shall be by a factory trained technician properly equipped to handle service within the next business day.
- H. Should any major system fail during the warranty period, response shall be within a four-hour period of notification by a factory trained technician properly equipped to handle service.

PART 2 - PRODUCTS

2.1 CAMERAS

- A. The Owner is accepting Video Surveillance Camera Manufacturers listed below with all necessary hardware and function:
 - 1. Axis
 - 2. Samsung
 - 3. Or approved equal with the following features:
 - a. 12 exterior cameras high resolution fixed dome cameras 4MegaPixel Motorize Lens 2.8-12mm, IP67, IK10, low light IR illumination.
 - b. 3 interior cameras high resolution fixed dome cameras 4MegaPixel Motorize lens 2.8-12mm, IP67, IK10, low light, IR illumination.
 - c. 1 license plate camera with Motorize Lens 4.7-47mm, F1.4, IP67, IK10.

**KOPACHUCK STATE PARK
DAY USE DEVELOPMENT**

2.2 NVR

- A. Video Surveillance NVR Manufacturers listed below with all necessary hardware and function:
1. S-VIDIA
 2. Or approved equal with the following features:
 - a. Record video by motion detection within 8x8 pixel area without using pre-recording.
 - b. Recording format must be Flexible Delta Compression (FDC).
 - c. Video stream must have 256bit encryption.
 - d. Must have live view and record on-high resolution stream (record at 4MegaPixel), high quality at 12-15 images per second.
 - e. License plate camera (record at 2MegaPixel) high quality at 15 images per second.
 - f. Network function for remote viewing, play back, control and alarm notification.
 - g. Simultaneous monitoring, recording, playback, smart motion search, license plate search.
 - h. Minimum 28 TB of internal storage.
 - i. Must provide up to 90 days of storage for all camera videos.
 - j. Must be able to access the NVR on the Washington State Parks network so the WSP department can view the streaming cameras with low bandwidth and high quality.
 - k. Must be able to access the NVR on the county's network so the WSP department can locate and download archived video.
 - l. Must be able to access the NVR using cell phone or mobile device via cellular broadband.
 - m. The VMS must work with mobile video security trailer (e.g. CCTVTrailer model SMT900) using FDC video compression.
 3. NVR, cameras and network equipment available from: CCTVRoom, 222 E 26th Street, Tacoma WA 98498 Phone (253) 683-2288 www.cctvroom.com Info about CCTVTrailer available from www.cctvtrailer.com

PART 3 - EXECUTION

3.1 NETWORK / COMMUNICATIONS

- A. Setup TCP/IP settings in accordance with Washington State Park standards and connect camera(s) to Kopachuck State Park network through existing network infrastructure utilizing Category 6 Gigabit Ethernet Cable.
- B. The physical cabling path must be shown on a drawing to be provided to Owner prior to installation.
- C. All cable runs must be within 328' as the standard.
- D. Ethernet extenders can be used after approval of Owner's Representative and after all other means have been exhausted.

**KOPACHUCK STATE PARK
DAY USE DEVELOPMENT**

- E. Prior to connecting camera(s) to the Kopachuck State Park network, program the cameras with the Owner provided IP address, sub net mask, gateway, user name and password.
- F. If an IDF is needed terminate data cabling into patch panel on the IDF end, label the patch panel port with the device number from the prints, and provide an appropriate length CAT6 patch cable to patch into the Kopachuck State Park NVR/switch. Patch cables shall be blue factory certified snag less with molded ends. Kopachuck State Park IT will inform the contractor of the switch port to plug into.
- G. Ensure that the testing device is set to the correct cable type. Errors in this selection will result in the contractor retesting without cost to Owner.
- H. Patch cables shall be installed around or on the side of any other equipment in the rack. Use Velcro for cable management. Wire ties or tape will not be accepted. No cabling should be vertically passing over other racked equipment. Test cabling and provide electronic versions of all test results.

3.2 VIDEO SECURITY EQUIPMENT INSTALLATION

- A. Examine pathway elements intended for cables. Check raceways and other elements for compliance with space allocations, installation tolerance, hazards to camera installation, and other conditions affecting installation.
- B. Examine roughing-in for LAN, WAN, and IP network before device installation.
- C. Proceed with installation only after unsatisfactory conditions have been corrected.

3.3 CAMERA INSTALLATION

- A. Prior to a camera installation, the Contractor shall field verify with Owner the exact camera installation location. It may become necessary for the Contractor to provide a camera and display the view on a laptop to show Owner the field of view prior to installation.
- B. Camera shall be surface mounted or pole mounted. In some instances, a mount may be required to capture the best possible view. Contractor shall provide the appropriate mounts for the installation. Mounts will need approval by Owner prior to installation.
- C. Camera lenses shall be covered with clear waterproof washable covers.
- D. Once installed the Contractor shall coordinate with Owner to review each camera live-recorded view. Contractor shall adjust camera accordingly for an acceptable view. Contractor shall provide a camera list and check off sheet, initialed by Owner or Owner's Representative, for each camera completed. If the view is not acceptable then the Contractor will have to adjust the camera until acceptable by the Owner or Owner's Representative.
- E. In some cases, the fixed camera lens may have to be rotated by 90-degrees/corridor format to get the field view available. In these cases, the camera view will not be rotated inside the SVIDIA VMS software but the camera/lens will have to be adjusted physically and within the cameras settings for the best possible view.

**KOPACHUCK STATE PARK
DAY USE DEVELOPMENT**

- F. If exterior fixed cameras are mounted off the roof a candy cane parapet mount shall be used. Camera shall be serviceable from the roof or ladder without a lift. A fabrication company shall be used and approved by Owner if parapet mount is needed.

3.4 VIDEO SURVEILLANCE SYSTEM INSTALLATION

- A. Install cameras level and plumb.
- B. Install cameras with 84-inch- (2134-mm-) minimum clear space below cameras and their mountings. Change type of mounting to achieve required clearance.
- C. Install all field and head-end equipment per manufacturer's recommendations and integrate as specified.
- D. Camera locations are approximate and shall be field verified with the Owner or Owner's Representative before actual installation for maximum field of view.
- E. Install all necessary mounts, connectors and other appurtenances required for a high-quality installation.
- F. Provide necessary programming of all camera titles and coordinate with Owner requirements. Minimally programming shall include:
 - 1. Camera title, date, and time.
 - 2. Camera (PTZ) prepositions, tours, etc.
 - 3. Camera dwell times, salvos, etc.
 - 4. NVR recording IP cameras minimally shall be 10 frames per second at full camera resolution.
 - 5. NVR configured with minimally 3 seconds of post -event recorded video.
- G. Provide field of view adjustments each fixed camera to meet the needs of the Owner.
- H. Provide necessary back focus and adjustments necessary for optimum night-time camera viewing, etc. where necessary.
- I. Provide NVR synchronization with network time.

3.5 CAMERA SETTINGS

- A. General:
 - 1. All cameras must be set for Maximum Bit Rate (MBR) functionality (recommended minimum 6Mbps). The actual rate will be determined at the time of install by the Owner and Contractor.
 - 2. The CODEC that should be used will be H.264 or MJPEG.
 - 3. The cameras shall be set for one main stream.
 - 4. The Owner shall determine the final Field of View (FOV) for the cameras. Final determinations will be decided at time of installation and will need to be signed off by the Owner prior to approval and installation.

**KOPACHUCK STATE PARK
DAY USE DEVELOPMENT**

5. The shutter speed for standard cameras shall be set at 1/120 mode. License plate cameras shall be set to 1/500-1/2000.
6. Motion sensing setup for cameras will be controlled by SVIDIA NVR. These settings are to be installed prior to final acceptance of finished project. Cameras to be set at motion recording will be determined after bid process and approved by the Owner.
7. Cross-Line, Vehicle and License plate Detection Capabilities should be set up by the Vendor with Owner, if applicable.
8. The Contractor will work with the Owner and immediately change the Username and Passwords for all equipment from the default factory settings.
9. Cameras must not have access to the general network and will use a dedicated network outside of the Washington state park network.

B. Minimum Frames Per Second Settings (FPS):

1. The multi-lens cameras at 10 fps
2. The static single lens cameras at 15 fps
3. The license plate camera at 15 fps

3.6 VIDEO MANAGEMENT SOFTWARE (VMS) & NVR (VCORE)

A. Provide SVIDIA VCore NVR (VCore):

1. The CODEC that should be used will be Flexible Delta Compression (FDC).
2. 28 TB Storage.
3. 16 camera licenses (included).
4. Capable of 16 licenses per recorder (maximum).

B. System shall support 8 concurrent mobile app connections and VMS client connections without loss of performance or viewing quality.

C. Contractor will be responsible for programming the camera(s) into the VMS (MMVC) per the Owner's specifications.

D. Provide one (1), three (3) and five (5) year options for maintenance agreement for the system installed.

E. Owner will preload the video servers and PC workstation with the VMS prior to delivery on site. Contractor shall provide Owner with the SVIDIA license prior to Owner shipping the server.

F. Install Owner provided equipment. This will include video server and storage as indicated on the drawing provided by Owner.

G. Install Owner provided PC workstations and monitors as indicated in specific scope of work.

3.7 UNINTERRUPTIBLE POWER SUPPLIES (UPS)

A. General:

**KOPACHUCK STATE PARK
DAY USE DEVELOPMENT**

1. The Contractor shall be provided with an up to a minimum of a 30-minute rated backup option power source within the rack(s) for uninterruptable power until power is resumed. The UPS will need to conform to the following characteristics/specifications.
 - a. Online double conversion
 - b. Minimum of 2200A
 - c. Minimum of 1800 watts
 - d. Must have .9 power factor or greater
 - e. Must be energy star qualified
 - f. Must have an economy mode option offers enhanced efficiency, reduced power consumption and lower BTU emissions
 - g. Must have an LCD interface
 - h. Must have battery independent restart to ensure automatic UPS power-up without user interaction after lengthy power outages, even when batteries are expired and requirement replacement
 - i. A UPS management card must be included or added on. Provide a minimum of 30-minute runtime at a 900-Watt load
 - j. The UPS shall be APC brand or Owner's approved equivalent.

3.8 FIELD QUALITY CONTROL

A. Tests and Inspections:

1. Inspection: Verify that units and controls are properly installed, connected, and labeled, and that interconnecting wires and terminals are identified.
2. Pretesting: Align and adjust system and pretest components, wiring, and functions to verify that they comply with specified requirements. Conduct tests at varying lighting levels, including day and night scenes as applicable. Prepare video-surveillance equipment for acceptance and operational testing as follows:
 - a. Prepare equipment list described in "informational Submittals" article.
 - b. Verify operation of auto-iris lenses.
 - c. Set back-focus of fixed focal length lenses. At focus set to infinity, simulate nighttime lighting conditions by using a dark glass filter of a density that produces a clear image. Adjust until image is in focus with and without the filter.
 - d. Set back-focus of zoom lenses. At focus set to infinity, simulate nighttime lighting conditions by using a dark glass filter of a density that produces a clear image. Additionally, set zoom to full wide angle and aim camera at an object 50 – 75 feet (17 to 23 m) away. Adjust until image is in focus from full wide angle to full telephoto, with the filter in place.
 - e. Set and name all present positions; consult Owner.
 - f. Set sensitivity of motion detection.
 - g. Connect and verify responses to alarms.

B. Video surveillance system will be considered defective if it does not pass tests and inspections.

C. Prepare test and inspection reports.

**KOPACHUCK STATE PARK
DAY USE DEVELOPMENT**

3.9 SYSTEM TRAINING

- A. Contractor shall provide eight (8) hours of onsite training after the completing of the installation. Training shall be set up into two (2) four hour sessions.
- B. Training dates and times shall be coordinated with the onsite Security Manager or Park Ranger.
- C. Training shall include the use of the SVIDIA, card access and Secure Remote Access Technology, if applicable.

3.10 SERVICE WARRANTY

- A. Contractor shall provide a one-year warranty on all part and labor for equipment provided. Warranty to start when all the cameras are fully installed and Owner has accepted completion.
- B. Service warranty does not include acts of God, lighting, flooding, tornado, earthquakes, etc. or third-party damage. These repairs will be identified by the Contractor, brought to the property manager's attention, quoted and approved before work is to be completed.
- C. Contractor shall respond on site to all service call requests the same day or the next business day from the first initiated call. Contractor can try to resolve the issue over the phone prior to dispatching a service technician. If holiday or weekend work is requested, Owner will pay the difference between the normal hourly rate and the overtime or holiday rate.
- D. If any parts that fail is not in the onsite inventory and not locally available then the Contractor shall purchase a replacement part and have it shipped in expedited overnight freight before 10am the next business day at Contractor's expense and have it installed the day it arrives.

3.11 ADJUSTING

- A. Occupancy Adjustments: When requested within 12 months of date of Substantial Completion, provide on-site assistance in adjusting system to suit actual occupied conditions. Provide up to two visits to Project during other-than-normal occupancy hours for this purpose. Tasks shall include, but are not limited to, the following:
 - 1. Check cable connections.
 - 2. Check proper operation of cameras and lenses. Verify operation of auto-iris lenses and adjust back-focus as needed.
 - 3. Adjust all present positions; consult Owner's personnel.
 - 4. Recommend changes to cameras, lenses, and associated equipment to improve Owner's use of video surveillance system.
 - 5. Provide a written report of adjustments and recommendations.

**KOPACHUCK STATE PARK
DAY USE DEVELOPMENT**

3.12 GENERAL WIRING

- A. The certified Contractor shall ensure that every aspect of the wiring system complies with the latest version of the ASNI EIA TIA standards and National Electrical Code (NEC).
- B. Coordinate the routing of wire and cable requiring isolation from power, radio frequency (RF), electromagnetic interference (EMI), telephone, etc. with the Owner. Route all wire and cable as required, to prevent interference and signal contamination.
- C. Route all wire and cable continuous from device location to the final point of termination. No mid-run cable splices shall be allowed.
- D. It shall be the responsibility of the certified Contractor to provide new cable supports (rings, trays, etc.) as necessary to install all system cabling as specified herein. At no time, shall any system cabling be allowed to 'lay' across ceiling tiles, cable trays, or existing building structures.
- E. All wire and cable shall be installed parallel and perpendicular to building structure and shall be neatly bundled and installed to TIA/EIA standards.
- F. All product submittals should be provided and approved prior to installation.
- G. Wiring shall be in EMT conduit. Outside conduit must have weatherproof fittings. PVC piping will not be permitted.

3.13 WIRING

- A. Comply with requirements in Section 260533 – Raceways and Boxes for Electrical Systems.
- B. Wiring Method: Install cables in raceways unless otherwise indicated.
 - 1. Except raceways are not required in accessible indoor ceiling spaces and attics.
 - 2. Except raceways are not required in hollow gypsum board partitions.
 - 3. Conceal raceways and wiring except in unfished spaces.
- C. Wiring within Enclosures: Bundle, lace, and train conductors to terminal points with no excess and without exceeding manufacturer's limitations on bending radii. Provide and use lacing bars and distribution spools.
- D. For LAN connection and fiber-optic and copper communication wiring, comply with Section 270500 – Common Work Results for Communications and Section 270533 – Conduits and Backboxes for Communications Cabling.
- E. Grounding: Provide independent-signal circuit grounding recommended in writing by manufacturer.

3.14 COPPER CABLING AND CONNECTIVITY

- A. The Contractor shall provide and install new CAT6e white plenum cabling for Network connectivity of all indoor cameras and CAT6e black gel filled for all outdoor cameras.

**KOPACHUCK STATE PARK
DAY USE DEVELOPMENT**

- B. The Contractor shall provide and install an extra length of 5' –a" of CAT6e cabling at each camera location for future use, camera relocation, etc. This should be split up evenly on both ends; 3.5' and 3.5'.
- C. The Contractor shall provide and install a patch panel for terminations at the MDF, if required.
- D. The Contractor shall provide and install all required category 6 patch cords for each patch panel location, lengths, and colors to be determined by Owner.
- E. The contractor shall provide and install a category 6 connector for each camera and jack patch panel location.
- F. The Contractor shall provide and install a single port surface mount box for each camera location.
- G. The Contractor shall provide and install a category 6 plenum patch cord from each RJ45 category 6 terminated jack into each installed camera.
- H. All installed CAT 6e cable will be tested and certified to the latest ANSI TIA/EIA 568-B.2 standards with a level IV tester (Fluke DSP or Ideal LanTek II).
- I. Outdoor Video Surveillance cameras Category 6 POE surge protection.
 - 1. The Contractor shall provide and install a CAT6-POE Category 6 surge protector for each outdoor camera location.

3.15 FIBER OPTIC CABLING AND CONNECTIVITY (IF NEEDED)

- A. If an IDF is needed.
 - 1. The Contractor shall provide a new four strand multimode tight buffered 50m 850/1300 Outdoor OM3 fiber optic cabling for Network connectivity between NVS distribution switches and the main NVS core switch.
 - 2. The Contractor shall provide a rack mount fiber panel for all fiber terminations.
 - 3. The Contractor shall provide an adapter panel in each opening of the fiber panel.
 - 4. The Contractor shall provide fiber optic cable preparation, installation, and LC 10G fiber connectors as recommended by the cable manufacturer.
 - 5. The Contractor shall submit an optical budget for each length of fiber optic cable defining the overall signal loss due to cable distance, connector loss, etc.
 - 6. All installed fiber will be tested and certified to ANSI TIA/EIA 568-B.2 standards with a level IV tester (Fluke OSP or Ideal LanTek II).

3.16 LABELING

- A. Fiber and copper cabling testing results are required for all cables installed. All network cables shall be certified with the test result printed and sent to Kopachuck State Park (or Washington State Parks) for verification prior to connecting to the network switch.
- B. Copper patch panels shall be labeled with the device numbers as indicated on the prints.

**KOPACHUCK STATE PARK
DAY USE DEVELOPMENT**

- C. There should not be any splices or termination between the patch panel and the end device.

3.17 ACCESS CONTROL

- A. IP based cameras can use I/O to control gate operation.

3.18 CLEANING

- A. Clean installed items using methods and materials recommended in writing by manufacturer.
- B. Clean video-surveillance-system components, including camera-housing windows, lenses, and monitor screens.

END OF SECTION 282300

**KOPACHUCK STATE PARK
DAY USE DEVELOPMENT**

SECTION 310000 - EARTHWORK

PART 1 - GENERAL

1.1 RELATED DOCUMENTS

- A. Drawings and general provisions of the Contract, including General Conditions and Division 1 Specification Sections, apply to this Section.

1.2 SUMMARY

- A. This Section includes the following:
 - 1. Grading to finish sub grade and preparing sub grades for slabs-on-grade, walks, pavements, and plantings.

1.3 DEFINITIONS

- A. Backfill: Soil materials used to fill an excavation.
- B. Borrow: Satisfactory (specified) soil imported from off-site for use as fill or backfill.
- C. Excavation: Removal of material encountered above sub grade elevations.
 - 1. Additional Excavation: Excavation below sub grade elevations as directed by Owner's Representative. Additional excavation and replacement material will be paid for according to Contract provisions for changes in the Work.
 - 2. Unauthorized Excavation: Excavation below sub grade elevations or beyond indicated dimensions without direction by Owner's Representative. Unauthorized excavation, as well as remedial work directed by Owner's Representative, shall be without additional compensation.
- D. Fill: Soil materials used to raise existing grades.
- E. Structures: Buildings, footings, foundations, retaining walls, slabs, tanks, curbs, mechanical and electrical appurtenances, or other man-made stationary features constructed above or below the ground surface.
- F. Sub grade: Surface or elevation remaining after completing excavation, or top surface of a fill or backfill immediately below sub base, drainage fill, or topsoil materials.
- G. Utilities include on-site underground pipes, conduits, ducts, and cables, as well as underground services within buildings.

**KOPACHUCK STATE PARK
DAY USE DEVELOPMENT**

1.4 SUBMITTALS

- A. Samples: For the following:
 - 1. ½ cubic foot samples, sealed in airtight containers, of each proposed soil material from borrow sources.
 - 2. Borrow.
- B. Material Test Reports: From a qualified testing agency indicating and interpreting test results for compliance of the following with requirements indicated:
 - 1. Sieve analysis by a certified testing laboratory of each material specified, showing the percent passing for each sieve size specified.
- C. Geotextile Fabric: Composite data sheet.

1.5 QUALITY ASSURANCE

- A. Pre-excavation Conference: Conduct conference at Project site.

1.6 PROJECT CONDITIONS

- A. Existing Utilities: Do not interrupt utilities serving facilities occupied by Owner or others unless permitted in writing by Owner and then only after arranging to provide temporary utility services according to requirements indicated:
 - 1. Notify Owner not less than two days in advance of proposed utility interruptions.
 - 2. Do not proceed with utility interruptions without Owner's written permission.
 - 3. Contact utility-locator service for area where Project is located before excavating.

PART 2 - PRODUCTS

2.1 NONWOVEN GEOTEXTILE FABRIC

- A. Nonwoven geotextile meeting or exceeding mullen burst of 220 psi (ASTM D3786 / D3786M), trapezoidal tear of 40 lbs. (ASTM D4533 / D4533M), and puncture strength of 65 lbs. (ASTM D4833 / D4833M). Mirafi 140N or approved equal.

2.2 SOIL MATERIALS

- A. Satisfactory Soils: On-site soil free of rock or gravel larger than 3 inches in any dimension, debris, waste, frozen materials, vegetation, and other deleterious matter.

**KOPACHUCK STATE PARK
DAY USE DEVELOPMENT**

- B. Unsatisfactory Soils: All other soils including:
 - 1. Satisfactory soils not maintained within 2 percent of optimum moisture content at time of compaction.
- C. Borrow (WSDOT 9-03.14): Provide borrow soil materials when sufficient satisfactory soil materials are not available from excavations. Aggregate for gravel borrow shall consist of granular material, either naturally occurring or processed, and shall meet the following requirements for grading and quality:

SIEVE SIZE	PERCENT PASSING
1 ¼" square	100 ¹
¼" square	25 min.
U.S. No 40	40 max.
U.S. No. 200	7.0 max.
Sand Equivalent	50 min.

All percentages are by weight.

¹If requested by the Contractor, the sieve size may be increased with the approval of the Owner's Representative if it is determined that larger size aggregate will be satisfactory for the specified backfilling or embankment construction.

- D. Backfill and Fill: Satisfactory soil materials.

PART 3 - EXECUTION

3.1 PREPARATION

- A. Protect structures, utilities, sidewalks, pavements, and other facilities from damage caused by settlement, lateral movement, undermining, washout, and other hazards created by earthwork operations.
- B. Protect sub grades and foundation soils against freezing temperatures or frost. Provide protective insulating materials as necessary.
- C. Provide erosion-control measures to prevent erosion or displacement of soils and discharge of soil-bearing water runoff or airborne dust to adjacent properties and walkways.

3.2 DEWATERING

- A. Prevent surface water and ground water from entering excavations, from ponding on prepared sub grades, and from flooding Project site and surrounding area.

**KOPACHUCK STATE PARK
DAY USE DEVELOPMENT**

- B. Protect sub grades from softening, undermining, washout, and damage by rain or water accumulation.
 - 1. Reroute surface water runoff away from excavated areas. Do not allow water to accumulate in excavations. Do not use excavated trenches as temporary drainage ditches.
 - 2. Install a dewatering system to keep sub grades dry and convey ground water away from excavations. Maintain until dewatering is no longer required.

3.3 EXCAVATION, GENERAL

- A. Unclassified Excavation: Excavation to sub grade elevations regardless of the character of surface and subsurface conditions encountered, including rock, soil materials, and obstructions.

3.4 EXCAVATION FOR STRUCTURES

- A. Excavate to indicated elevations and dimensions within a tolerance of plus or minus tenth-foot (.10'). Extend excavations a sufficient distance from structures for placing and removing concrete formwork, for installing services and other construction, and for inspections.
 - 1. Excavations for Footings and Foundations: Do not disturb bottom of excavation. Excavate by hand to final grade just before placing concrete reinforcement. Trim bottoms to required lines and grades to leave solid base to receive other work.
 - 2. Excavation for Underground Mechanical or Electrical Utility Structures: Excavate to elevations and dimensions indicated within a tolerance of plus or minus 1 inch. Do not disturb bottom of excavations intended for bearing surface.

3.5 EXCAVATION FOR WALKS AND PAVEMENTS

- A. Excavate surfaces under walks and pavements to indicated cross sections, elevations, and grades.

3.6 APPROVAL OF SUBGRADE

- A. Notify Owner's Representative when excavations have reached required sub grade.
- B. Cut Areas: After cutting to finish sub grade, proof roll sub grade at all cut areas to receive paving or structures with heavy pneumatic-tired equipment or a 2,000 lb. roller to identify soft pockets and areas of excess yielding. Do not proof roll wet or saturated sub grades.
 - 1. Any soft cut areas identified by the Owner's Representative, and if directed by the Owner's Representative, shall be over excavated to a depth determined by the Owner's Representative, and the excavated material re-compacted.
 - 2. Payment for removal and re-compaction shall be negotiated.
 - 3. In the event the other Owner's Representative determines the existing soil to be unsuitable, the cost for removal and replacement with borrow shall be negotiated.

**KOPACHUCK STATE PARK
DAY USE DEVELOPMENT**

- C. Reconstruct sub grades damaged by freezing temperatures, frost, rain, accumulated water, or construction activities, at the Contractor's expense.

3.7 UNAUTHORIZED EXCAVATION

- A. Fill unauthorized excavation under foundations or wall footings by extending bottom elevation of concrete foundation or footing to excavation bottom, without altering top elevation. Lean concrete fill may be used when approved by Owner's Representative.
 - 1. Fill unauthorized excavations under other construction or utility pipe as directed by Owner's Representative.

3.8 STORAGE OF SOIL MATERIALS

- A. Stockpile borrow materials and satisfactory excavated soil materials. Stockpile soil materials without intermixing. Place, grade, and shape stockpiles to drain surface water. Cover to prevent windblown dust.
 - 1. Stockpile soil materials away from edge of excavations. Do not store within drip line of remaining trees.

3.9 BACKFILL

- A. Place and compact backfill in excavations promptly, but not before completing the following:
 - 1. Surveying locations of underground utilities for record documents.
 - 2. Inspecting and testing underground utilities.
 - 3. Removing concrete formwork.
 - 4. Removing trash and debris.
 - 5. Removing temporary shoring and bracing, and sheeting.
 - 6. Installing permanent or temporary horizontal bracing on horizontally supported walls.

3.10 FILL

- A. Preparation: Remove vegetation, topsoil, debris, unsatisfactory soil materials, obstructions, and deleterious materials from ground surface before placing fills.
- B. Plow, scarify, bench, or break up sloped surfaces steeper than 1 vertical to 4 horizontal so fill material will bond with existing material.
- C. Place and compact fill material in layers as specified to required elevations to the specified densities.

3.11 MOISTURE CONTROL

- A. Uniformly moisten or aerate sub grade and each subsequent fill or backfill layer before compaction to within 2 percent of optimum moisture content.

**KOPACHUCK STATE PARK
DAY USE DEVELOPMENT**

1. Do not place backfill or fill material on surfaces that are muddy, frozen, or contain frost or ice.
2. Remove and replace, or scarify and air-dry, otherwise satisfactory soil material that exceeds optimum moisture content by 2 percent and is too wet to compact to specified dry unit weight.

3.12 **COMPACTION OF BACKFILLS AND FILLS**

- A. Place backfill and fill materials in layers not more than 8 inches in loose depth for material compacted by heavy compaction equipment, and not more than 4 inches in loose depth for material compacted by hand-operated tampers.
- B. Place backfill and fill materials evenly on all sides of structures to required elevations, and uniformly along the full length of each structure.
- C. Compact soil to not less than the following percentages of maximum dry unit weight according to ASTM D 1557:
 1. Under structures, building slabs, steps, and pavements, scarify and re-compact top 12 inches of existing sub grade and each layer of backfill or fill material at 95 percent.
 2. Under walkways, scarify and re-compact top 6 inches below sub grade and compact each layer of backfill or fill material at 95 percent.
 3. Under unpaved areas, scarify and re-compact top 6 inches below sub grade and compact each layer of backfill or fill material at 85 percent.

3.13 **GRADING**

- A. General: Uniformly grade areas to a smooth surface, free from irregular surface changes. Comply with compaction requirements and grade to cross sections, lines, and elevations indicated.
 1. Provide a smooth transition between adjacent existing grades and new grades.
 2. Cut out soft spots, fill low spots, and trim high spots to comply with required surface tolerances.
- B. Site Grading: Slope grades to direct water away from building pad sites and to prevent ponding. Finish sub grades to required elevations within the following tolerances:
 1. Unpaved Areas: Plus or minus 1 tenth foot (0.10').
 2. Pavements: Plus or minus 0.05'.
 3. Walks: Plus or minus 1 tenth foot (0.10').
- C. Grading Inside Building Lines: Finish sub grade to a tolerance of 0.05' when tested with a 10-foot straightedge.

**KOPACHUCK STATE PARK
DAY USE DEVELOPMENT**

3.14 FIELD QUALITY CONTROL

- A. Testing Agency: Owner will engage a qualified independent geotechnical engineering testing agency to perform field quality control testing.
- B. Allow testing agency to inspect and test sub grades and each fill or backfill layer. Proceed with subsequent earthwork only after test results for previously completed work complies with requirements.
- C. Footing Sub grade: At footing sub grades, at least one test of each soil stratum will be performed to verify design-bearing capacities. Subsequent verification and approval of other footing sub grades may be based on a visual comparison of sub grade with tested sub grade when approved by Owner's Representative.
- D. Testing agency will test compaction of soils in place according to ASTM D 1556, ASTM D 2167, ASTM D 2922, and ASTM D 2937, as applicable. Tests will be performed at the following locations and frequencies:
 - 1. Paved and Building Slab Areas: At sub grade and at each compacted fill and backfill layer, at least one test for every 2,000 sq. ft. or less of paved area or building slab, but in no case fewer than three tests.
 - 2. Foundation Wall Backfill: At each compacted backfill layer, at least one test for each 100 feet or less of wall length, but no fewer than two tests.
 - 3. Trench Backfill: At each compacted initial and final backfill layer, at least one test for each 150 feet or less of trench length, but no fewer than two tests.
- E. When testing agency reports that sub grades, fills, or backfills have not achieved degree of compaction specified, scarify and moisten or aerate, or remove and replace soil to depth required; re-compact and retest until specified compaction is obtained.

3.15 PROTECTION

- A. Protecting Graded Areas: Protect newly graded areas from traffic, freezing, and erosion. Keep free of trash and debris.
- B. Repair and reestablish grades to the specified tolerances where completed or partially completed surfaces become eroded, rutted, settled, or where they lose compaction due to subsequent construction operations or weather conditions.
 - 1. Scarify or remove and replace soil material to depth as directed by Owner's Representative; reshape and re-compact.
- C. Where settling occurs before Project correction period elapses, remove finished surfacing, backfill with additional soil material, compact, and reconstruct surfacing.
 - 1. Restore appearance, quality, and condition of finished surfacing to match adjacent work, and eliminate evidence of restoration to the greatest extent possible.

**KOPACHUCK STATE PARK
DAY USE DEVELOPMENT**

3.16 DISPOSAL OF SURPLUS AND WASTE MATERIALS

- A. Disposal: Unless otherwise specified, remove surplus satisfactory soil and waste material, including unsatisfactory soil, trash, and debris, and legally dispose of it off Owner's property.

3.17 BORROW

- A. The Contractor shall be responsible for determining quantities of cut and fill. In the event there is insufficient on-site fill material, use import borrow. The cost for import borrow shall be included in the lump sum contract price.

END OF SECTION 310000

**KOPACHUCK STATE PARK
DAY USE DEVELOPMENT**

SECTION 311000 – SITE CLEARING

PART 1 - GENERAL

1.1 RELATED DOCUMENTS

- A. Drawings and general provisions of the Contract, including General Conditions and Division 1 Specification Sections, apply to this Section.

1.2 SUMMARY

- A. This Section includes the following:
 - 1. Protecting existing trees and vegetation to remain.
 - 2. Removing trees and other vegetation.
 - 3. Clearing and grubbing.

1.3 RELATED SECTIONS

- A. Related work in other sections include, but is not limited to:
 - 1. Section 015639 – Temporary Tree and Plant Protection

1.4 MATERIALS OWNERSHIP

- A. Except for materials indicated to be stockpiled and reused onsite or to remain Owner's property, cleared materials shall become Contractor's property and shall be removed from the site.

1.5 SUBMITTALS

- A. Photographs or videotape, sufficiently detailed, of existing conditions of trees and plantings, adjoining construction, and site improvements that might be misconstrued as damage caused by site clearing.
- B. Record drawings according to Division 1, Section 017700 – Closeout Procedures.
 - 1. Identify and accurately locate capped utilities and other subsurface structural, electrical, and mechanical conditions.

1.6 QUALITY ASSURANCE

- A. Pre-installation Conference: Conduct conference at Project site to comply with requirements in Division 1.

**KOPACHUCK STATE PARK
DAY USE DEVELOPMENT**

1.7 PROJECT CONDITIONS

- A. Traffic: Minimize interference with adjoining roads, streets, walks, and other adjacent occupied or used facilities during site-clearing operations.
 - 1. Do not close or obstruct streets, walks, or other adjacent occupied or used facilities without permission from Owner and authorities having jurisdiction.
 - 2. Provide alternate routes around closed or obstructed traffic ways if required by authorities having jurisdiction.
- B. Conduct a private utility locator service for the entire area before site clearing.

PART 2 - PRODUCTS (NOT USED)

PART 3 - EXECUTION

3.1 PREPARATION

- A. Protect and maintain benchmarks and survey control points from disturbance during construction.
- B. Provide erosion-control measures to prevent soil erosion and discharge of soil-bearing water runoff or airborne dust to adjacent properties and walkways.
- C. Locate and clearly flag trees and vegetation to remain or to be relocated.
- D. Protect existing site improvements to remain from damage during construction.
 - 1. Restore damaged improvements to their original condition, as acceptable to Owner.

3.2 UTILITIES

- A. Existing Utilities: Do provide temporary utility services according to requirements indicated:
 - 1. Notify Owner's Representative not less than two days in advance of proposed utility interruptions.
 - 2. Do not proceed with utility interruptions without Owner's written permission.
- B. Excavate for and remove underground utilities indicated to be removed.

**KOPACHUCK STATE PARK
DAY USE DEVELOPMENT**

3.3 CLEARING AND GRUBBING

- A. Remove obstructions, trees, shrubs, grass, and other vegetation to permit installation of new construction. Removal includes digging out stumps and obstructions and grubbing roots.
 - 1. Do not remove trees, shrubs, and other vegetation indicated to remain or to be relocated.
 - 2. Cut minor roots and branches of trees indicated to remain in a clean and careful manner where such roots and branches obstruct installation of new construction.
 - 3. Completely remove stumps, roots, obstructions, and debris extending to a depth of 18 inches below exposed sub grade.
 - 4. Use only hand methods for grubbing within drip line of remaining trees.
- B. Fill depressions caused by clearing and grubbing operations with satisfactory soil material, unless further excavation or earthwork is indicated.
 - 1. Place fill material in horizontal layers not exceeding 8-inch loose depth, and compact each layer to a density equal to adjacent original ground.

3.4 SITE IMPROVEMENTS

- A. Remove existing above- and below-grade improvements as indicated and as necessary to facilitate new construction.
- B. Remove slabs, paving, curbs, gutters, and aggregate base as indicated.
 - 1. Unless existing full-depth joints coincide with line of demolition, neatly saw-cut length of existing pavement to remain before removing existing pavement. Saw-cut faces vertically.

3.5 DISPOSAL

- A. Disposal: Unless otherwise noted, remove surplus soil material, unsuitable topsoil, obstructions, demolished materials, and waste materials, including trash and debris, and legally dispose of them off Owner's property.

END OF SECTION 311000

**KOPACHUCK STATE PARK
DAY USE DEVELOPMENT**

SECTION 312000- EARTHWORK (UTILITY TRENCHING)

PART 1 GENERAL

1.1 DESCRIPTION OF WORK

- A. Work in this section consists of excavation, shoring, backfilling, compacting and grading of utility trenches.

1.2 RELATED SECTIONS

- A. Section 331000 - Water Utility System
- B. Section 333000 - Sanitary Sewer
- C. Section 333200 - On-Site Sewage

1.3 REFERENCES

- A. American National Standards Institute /American Society of Safety Engineers (ANSI/ASSE)
 - 1. ANSI/ASSE A10.6 (2006) Safety and Health Program Requirements for Demolition Operations
- B. ASTM International (ASTM)
 - 1. ASTM C136 (2014) Standard Test Methods for Sieve Analysis for Fine and Course Aggregates
 - 2. ASTM D1557 (2012) Standard Test Methods for Laboratory Compaction Characteristics for Soil Using Modified Effort
- C. Washington Department of Transportation (WSDOT)
 - 1. (2018) Standard Specifications – Standard Specifications for Road, Bridge, and Municipal Construction.

1.4 SUBMITTALS

- A. Submit the following documents as PDF's via e-mail for all imported fill material described in Part 2 and on-site material to be incorporated into the Work:
 - 1. Sieve analysis.
 - 2. Certified test results of moisture content and chemical constituents for the imported fill materials, either through documentation of existing chemical analyses or by project-specific testing and analysis, as directed by Parks. At minimum, materials obtained from commercial quarries shall have a total arsenic level less than 20 mg/kg for diesel and oil

**KOPACHUCK STATE PARK
DAY USE DEVELOPMENT**

range hydrocarbons and below laboratory reporting limits for gasoline. Borrow from sources other than commercial quarries may be subject to additional testing depending on the source and as directed by Parks.

3. Modified proctor results for materials to be compacted.

- B. The Contractor shall submit to the Engineer the following information regarding each geotextile proposed for use:

1. Manufacturer's name and current address.
2. Full product name.
3. Geotextile structure, including fiber/yarn type.
4. Proposed geotextile uses(s).
5. Manufacturer's Certificate of Compliance.

1.5 JOBSITE

- A. Earthwork operations shall not be performed if the weather conditions, in the opinion of the Engineer, are inappropriate. Work in muddy or frozen ground will not be allowed.

- B. Maintain proper drainage at all times.

- C. Stockpiles:

1. All stockpile locations shall be approved by the Engineer and shall be located so as not to interfere with other work or disturb adjoining property owners.
2. Stockpiles shall not exceed 10 feet in height.

- D. Contractor shall maintain stormwater and erosion controls at all times.

1.6 PROJECT CONDITIONS

- A. The Contractor shall conform to all recommendations and conditions indicated in the soil report.

- B. Contractor shall barricade open excavations occurring as part of this Work and post warning lights. Operate warning lights during hours from dusk to dawn each day and as otherwise required by applicable safety regulations.

- C. Contractor shall be responsible for contacting utility companies to locate service lines prior to any excavation.

- D. Contractor shall proceed with caution in the excavation so that damage to underground structures, both known and unknown, may be avoided.

- E. Contractor shall take extreme precautions for the protection of utility lines and other subsurface improvements. Any improvements damaged by construction operations shall be repaired at the Contractor's expense in compliance with the requirements of the utility owner and to the Engineer's satisfaction.

**KOPACHUCK STATE PARK
DAY USE DEVELOPMENT**

- F. Trenches and excavations shall be sheeted, shored, and braced where required in a manner consistent with established safe practices and in accordance with all applicable safety regulations.
- G. Contractor shall comply with Chapter 49.17 RCW, the Washington State Industrial Safety and Health Act, if trench excavation exceeds 4 feet in depth. Contractor shall also include cost of required safety systems in all bid schedules as incidental to the related earthwork pay item.
- H. Contractor shall provide all materials, equipment, and labor necessary to provide support to manholes, footings, and foundation walls during excavation and backfilling at all locations.

PART 2 PRODUCTS

2.1 EXCAVATION MATERIALS

- A. All excavated material may be reused as suitable native material provided it is free-draining, granular, free of organics and wood debris, and compactable with no greater than 8% fines and maximum particle size of 6-inches. Any non-suitable excavated shall be exported off site.

2.2 FILL MATERIALS

- A. Imported Trench Backfill - Shall be gravel borrow or CSBC and meet the following requirements when tested in accordance with ASTM C136 and WSDOT Standard Specification Section 9-03.14(1) and 9-03.9(3).
- B. Pipe Bedding: Pipe bedding material shall comply with WSDOT Standard Specification Section 9-03.12(3)
- C. Drain Rock shall comply with WSDOT Standard Specification Section for permeable ballast 9-03.9(2).
- D. Quarry spalls: meet the following gradation in accordance with WSDOT 9-13.6:

TABLE 02220 - 2.02H	
Sieve Designation	Percent Passing by Weight
8 Inch Square	100
3 Inch Square	40 Maximum
¾ Inch Square	10 Maximum

2.3 GEOTEXTILE

- A. Geotextiles used on the project shall comply with WSDOT Standard Specification Section 9-33. Geotextiles used in each specific application shall comply with Tables 1 through Table 8 of

**KOPACHUCK STATE PARK
DAY USE DEVELOPMENT**

WSDOT Standard Specification Section 9-33.2(1), based on the summary table specifying use within Section 9-33.1.

PART 3 EXECUTION

3.1 EXCAVATION

- A. Large rocks, which size qualifies them as common excavation, encountered during excavation or trenching may be partially removed as required to reach subgrade elevations. With Engineer's approval, Contractor shall have the option to remove these rocks by excavation and subsequent backfilling the over-excavated portions. No extras will be paid for such over-excavations.
- B. Contractor shall protect bottoms of all excavations from freestanding water and frost. Protect excavations from caving, flooding, or other source of damages. Damage to excavation shall be repaired at the Contractor' expense.
- C. Any excess excavation performed by the Contractor for his convenience shall be at the expense of the Contractor.
- D. Contractor shall dispose of all excavated materials at a permitted offsite location. Prior to disposal, Contractor shall provide the Engineer with a letter authorizing disposal at selected locations.
- E. Excavated materials of any nature in excess of quantities needed for fill or backfill for construction of this project shall be disposed of by Contractor. This disposal will not be considered a change in Work, and no extra payment will be made.
- F. Any excavation and replacement of unsuitable materials below subgrade shall be as directed by the Engineer. "Unsuitable material" is any type of soil (particularly clays and silts) or organic materials that will not compact to specified compaction percentage or does not meet the specification for its intended use.
- G. All trenches shall apply with applicable OSHA requirements.
- H. All excavations shall be properly backfilled but not behind retaining walls before concrete or masonry attains its full design strength.

3.2 BACKFILL AND COMPACTION

- A. The Contractor shall place no backfill materials until the utility trenches have been suitably dewatered and prepared as specified herein.
- B. When backfilling, the Contractor shall take extra care so that no damage to utilities occur.

**KOPACHUCK STATE PARK
DAY USE DEVELOPMENT**

- C. The Contractor shall spread each lift of fill material uniformly in horizontal layers and compact in maximum 6-inch lifts to 95 percent compaction dry density by modified proctor as determined in accordance with ASTM D1557.
- D. Compaction shall be accomplished with power-operated tampers, rollers, idlers, or vibratory equipment.
- E. Any application of water or any working of fill material required to bring it within acceptable moisture content and density limits during compaction operations shall be done at the Contractor's expense.
- F. Backfill materials shall not be placed, spread, or compacted at unsuitably high moisture content during adverse weather conditions. When Work is interrupted by heavy rain, backfill operations shall not be resumed until field tests indicate the moisture content density of the backfill areas are within specified limits.
- G. Compaction testing will be performed by Contractors special inspector.

3.3 GEOTEXTILE INSTALLATION

- A. The filter fabric shall be placed as shown on the Drawings. The surface to receive the fabric shall be prepared to a smooth, uniform condition free of obstructions, protrusions, depressions, and debris.
- B. The geotextile shall be spread immediately ahead of the covering operation.
- C. Under no circumstances shall the geotextile be dragged through mud or over sharp objects that could damage the geotextile.
- D. The fabric shall not be laid in a stretched condition, but laid loosely and smoothly without excessive wrinkles.
- E. In all other applications, the geotextile shall be overlapped a minimum of 3 feet at all longitudinal and transverse joints or the geotextile joints shall be sewn together.
- F. Contractor shall use pegs, pins, or the manufacturer's recommended method as needed to hold the geotextile in place until the specified cover material is placed.

3.4 SPECIAL INSPECTIONS

- A. Continuous
- B. Verify use of proper materials, densities and lift thicknesses during placement and compaction of controlled fills
- C. Periodic
 - 1. Perform classification and testing of controlled fill materials.

**KOPACHUCK STATE PARK
DAY USE DEVELOPMENT**

2. Verify excavations are extended to proper depth and have reached proper material.
3. Verify materials below footings are adequate to achieve design bearing capacity.
4. Prior to placement of controlled fill, inspect subgrade and verify that site has been prepared properly.

END OF SECTION 312000

**KOPACHUCK STATE PARK
DAY USE DEVELOPMENT**

SECTION 321216 – ASPHALT CONCRETE PAVEMENT AND PAVEMENT MARKING

PART 1 - GENERAL

1.1 RELATED DOCUMENTS

- A. Drawings and general provisions of the Contract, including General Conditions and Division 1 Specification Sections, apply to this Section.

1.2 SUMMARY

- A. This Section includes:
 - 1. Asphalt paving.
 - 2. Paint striping.

1.3 QUALITY ASSURANCE

- A. Asphalt contractor to attend a pre-construction conference with the general contractor and Owner's Representative prior to mobilizing for paving.

1.4 ALTERNATES

- A. See Form of Bid Proposal for possible affect on this section.

1.5 RELATED WORK

- A. Coordinate related work and requirements specified in other parts of the Contract Documents, including but not limited to the following:
 - 1. Section 310000 – Earthwork

1.6 REFERENCE STANDARDS

- A. Standard Specifications: All construction shall be in accordance with the Standard Specification for Road, Bridge, and Municipal Construction," prepared by the Washington State Department of Transportation (WSDOT) and the American Public Works Association, Washington State Chapter.

1.7 SUBMITTALS

- A. Submit sieve analysis from a certified testing laboratory showing conformance to the sieve sizes listed and sample of crushed rock material (1/4 cubic foot).

**KOPACHUCK STATE PARK
DAY USE DEVELOPMENT**

- B. Submit composite data sheets on paint striping materials.

PART 2 - PRODUCTS

2.1 CRUSHED ROCK

- A. Base Course: One and one-quarter inch (1 ¼") minus base course shall meet the requirements as outlined in Section 9.03.9(3) of the Standard Specifications.
- B. Compacted Depth: See details.

2.2 ASPHALT

- A. Asphalt paving shall conform to 5-04, 9-02 and 9-03 of the Standard Specifications.
 - 1. Roads and Parking Lot: HMA Class ½" PG 58-22 Class B.
 - 2. 56th Street Path: HMA Class 3/8" PG 58-22 Class G.

2.3 JOINT SEALER

- A. AR-4000 joint sealer.

2.4 PAVEMENT MARKING

- A. Material: Material shall conform to Section 8-22.2 of the Standard Specifications.
- B. Striping: White exterior Type, chlorinated rubber paint. Four-inch typical width for parking stalls.
- C. Handicapped Parking Stall Symbol, Stop Bar and "Stop", and Traffic Arrow: White markings conforming to specifications shown in the *Manual on Uniform Traffic Control Devices* (MUTCD), latest edition.

PART 3 - EXECUTION

3.1 SUBGRADE

- A. Prepare subgrade in conformance with Section 310000 - Earthwork.
- B. Verify that the subgrade is completed to correct line and grade before starting work.

**KOPACHUCK STATE PARK
DAY USE DEVELOPMENT**

3.2 CRUSHED ROCK

- A. Construct crushed surfacing in accordance with Section 4-04 of the Standard Specifications.

3.3 ASPHALT

- A. All Paving: Construct in accordance with Section 5-04 of the Standard Specifications.
- B. Obtain approval of crushed rock base course prior to paving.

3.4 SAW-CUT JOINTS

- A. Sawcut existing and new joints between paving.

3.5 JOINT SEALING

- A. Seal butt joints between new and existing paving.

3.6 PAVEMENT MARKING

- A. Prepare surface in conformance to Section 8-22 of the Standard Specifications. Paint only when air and surface to be painted temperatures are above 50 degrees F. Line width shall not vary more than plus or minus 1/4".

3.7 ASPHALT FINISHED EDGE

- A. All asphalt surface pavement edges will be at true alignment and width as indicated on the plans.
- B. All asphalt surface edges not abutting concrete paving shall be hand tamped to a 45-degree angle as shown on the plans.

END OF SECTION 321216

**KOPACHUCK STATE PARK
DAY USE DEVELOPMENT**

SECTION 321313- CAST-IN-PLACE CONCRETE

PART 1 GENERAL

1.1 DESCRIPTION OF WORK

A. Work in this section includes the following:

1. The Work under this Section includes providing all labor, materials, tools and equipment necessary for furnishing and installing cast-in-place concrete for retaining walls in conformance with the Drawings and Specifications.

1.2 RELATED SECTIONS

- A. Section 031000 – Concrete Forming
- B. Section 032000 – Concrete Reinforcing

1.3 REFERENCES

A. ACI (American Concrete Institute) Manual of Concrete Practice

1. ACI 318 (2014) Building Code Requirements for Structural Concrete and Commentary
2. ACI 347 (2014) Recommended Practice for Concrete Formwork

B. ASTM International (ASTM)

1. A29 (2016) Standard Specification for General Requirements for Steel Bars, Carbon and Alloy, Hot-Wrought
2. ASTM A706 (2014) Standard Specification for Low-Alloy Steel Deformed and Plain Bars for Concrete Reinforcement
3. ASTM C31 (2012) Standard Practice for Making and Curing Concrete Test Specimens in the Field
4. ASTM C33 (2013) Standard Specification for Concrete Aggregates
5. ASTM C143 (2015) Standard Test Method for Slump of Hydraulic-Cement Concrete
6. ASTM C150 (2015) Standard Specification for Portland Cement
7. ASTM C260 (Er. 2006, 2010a) Standard Specification for Air-Entraining Admixtures for Concrete
8. ASTM C330 (2017) Standard Specification for Lightweight Aggregates for Structural Concrete
9. ASTM C494 (2013) Standard Specification for Chemical Admixtures for Concrete
10. ASTM C618 (2015) Standard Specification for Coal Fly Ash and Raw or Calcined Natural Pozzolan for Use in Concrete
11. PCI MNL-116 Quality Control for Plants and Production of Structural Precast Concrete Products.

**KOPACHUCK STATE PARK
DAY USE DEVELOPMENT**

- C. Washington State Department of Transportation (WSDOT)
 - 1. (2018) Standard Specification for Road, Bridge, and Municipal Construction; and Amendments

1.4 SUBMITTALS

- A. Delivery tickets for all concrete delivered to the site.
- B. Concrete Mix Design. Mix design shall include manufacturer's data stating material properties, installation instructions for all materials included in the concrete mix design. Manufacturer's data shall demonstrate that is in conformance to all specifications and standards outlined in these specifications and referenced standards.
- C. Material certificates certifying conformance to ASTM C150.
- D. Material certificates and sieve analysis for aggregates.
- E. Slump Test results for each load of concrete delivered to the project site in conformance with ASTM C143.
- F. Air Entrainment test results for each load of concrete delivered to the project site in conformance with ASTM C260.
- G. Material certificates for any other admixtures used.
- H. Material test reports consisting of one set of test cylinders for every 50 cubic yards of concrete delivered to the site, with the creation of the cylinders as directed in ASTM C31.
- I. Manufacture's product data for waterstops, bonding agents, vapor retardants, joint filler, curing materials, anti-graffiti coatings, and floor treatments.
- J. Shop drawings for proposed locations of additional construction or control joints not shown on the structural joints.
- K. Minutes from pre-installation conference.

1.5 DELIVERY, STORAGE AND HANDLING

- A. Deliver all structural precast concrete members in such quantities and at such times to assure compliance with the agreed upon project schedule and setting sequence to ensure continuity of installation.
- B. Handle and transport members in a manner to avoid excessive stresses that could cause cracking or other damage.
- C. Store units with adequate dunnage and bracing, and protect units to prevent contact with soil, staining, and to control cracking, distortion, warping or other physical damage.

**KOPACHUCK STATE PARK
DAY USE DEVELOPMENT**

- D. Unless otherwise specified or shown on Shop Drawings, store members with dunnage across full width of each bearing point.
- E. Place stored members so identification marks are clearly visible, and units can be inspected.
- F. Place dunnage of even thickness between each member.
- G. Lift and support members only at designated points indicated on the Shop Drawings.

PART 2 PRODUCTS

2.1 COMPOSITION OF CONCRETE

- A. All Portland cement concrete shall be ready mix, provided by an approved plant regularly engaged in the production of concrete, unless otherwise authorized in writing by the Engineer. Ready mix concrete shall conform to the requirements of ASTM C494.
- B. The Contractor shall furnish the mix design to the Engineer for approval. The mix design shall be suitable for its intended use. Concrete shall be designed using an absolute volume analysis. The Contractor shall be responsible for having each mix laboratory tested. Prior to the start of production of any mix design, the Contractor shall submit test results and certifications for all materials, detailed mix design data and results of laboratory tests to the Engineer for approval. Approval by the Engineer will be based on apparent conformity to these specifications. It shall remain the Contractor's responsibility during production to produce concrete conforming to the mix design and the minimum acceptance criteria in the contract. When requested by the Engineer, the Contractor shall submit samples of all materials for verification testing. Production shall not commence until the mix design is approved by the Engineer.
- C. Do not use concrete containing chlorides.

2.2 MIX CRITERIA

- A. Concrete mix design and testing shall meet the requirements of the building, code and specifications. All concrete mixes shall be designed by a recognized testing lab stamped and sealed by a licensed civil engineer in the state where the work is being performed and submitted to the Engineer of Record (E.O.R.) for review prior to concrete placement. Structural concrete mixes shall consist of 5 sack minimum, unless notified otherwise.
- B. Cast in Place (C.I.P.)
 - 1. All cast-in-place concrete for bulkhead cap, slabs, sign posts, bollards and fence posts shall be standard weight, Portland cement concrete appropriately proportioned to meet or exceed the following minimum requirements for strength and serviceability.
 - 2. Minimum 28-day compressive strength $f'c = 4,500$ psi
 - 3. Maximum water cement ratio = 0.45
 - 4. Air Entrainment = 4% to 8%
 - 5. Slump:
 - a. Foundation and Slab on Grade = 4" Max

**KOPACHUCK STATE PARK
DAY USE DEVELOPMENT**

- b. All other concrete = 6" max.
- 6. Maximum dry unit weight of lightweight concrete shall be 115 PCF, unless approved by the E.O.R.
- 7. Lean concrete where specifically indicated, shall contain 2 sacks of cement per cubic yard of concrete.

C. Mixture Substitutions

- 1. Fly ash or other pozzolans conforming to ASTM C618 class N or F may be used as a partial substitution for Portland cement up to a maximum of 25% total cementitious materials by weight if the mix design is proportioned by method B or C.

2.3 AGGREGATES

- A. Aggregates shall conform to ASTM C33 (hardrock), with maximum aggregate size as follows:

Location	Max. Aggregate Size
Foundations	1.5"
Slab on Grade	1.0"
Fill Over Metal Deck	0.75"
All Other Structural Concrete	1.0"

- B. Aggregates in light weight concrete shall conform to ASTM C330.
- C. Aggregates shall be stored so as to prevent deterioration, segregation and intrusion of foreign material.

2.4 ADMIXTURES

- A. Any additives must have prior approval of the Engineer before being used.
- B. Admixtures, if used, including water reducers, retarders, and accelerators, shall conform to ASTM C494. Calcium chloride shall not be used. All admixtures used shall be submitted for approval with the Concrete Mix Design.

2.5 AIR ENTRAINING AGENTS

- A. Air entraining mixtures shall conform to ASTM C260.

2.6 MIXING WATER

- A. Water used for the mixing of concrete shall be potable and be free of foreign materials. Water containing 2 percent or more salt shall not be used.

**KOPACHUCK STATE PARK
DAY USE DEVELOPMENT**

2.7 SHIPPING AND STORAGE OF CEMENT

- A. Cement may be shipped from pretested approved bins. The cement shall be well protected from rain and moisture, and any cement damaged by moisture or which fails to meet any of the specified requirements shall be rejected and removed from the work.
- B. Cement stored by the Contractor for a period longer than sixty (60) days in other than sealed bins or silos shall be retested before being used. Cement of different brands, types, or from different mills shall be stored separately.
- C. All expansion anchors shall be Hilti Kwik Bolt 3 or approved equal.
- D. All substitutions shall have a current, approved ICC-ES or IAPMO test report.

2.8 ANTI-GRAFFITI COATING

- A. Anti-graffiti coating shall be Fabrishield PR-60 Paint Repellent or approved equal.

PART 3 EXECUTION

3.1 GENERAL

- A. Concrete shall be mixed, placed and cured in accordance with ACI 318 latest edition and these specifications.
- B. Concrete mixing operations shall conform to ASTM C494.
- C. All concrete shall be placed before it has taken its initial set and, in any case, within 90 minutes after mixing. Concrete shall be placed in such manner as to avoid segregation of coarse or fine portions of the mixture, and shall be spread in horizontal layers when practicable. Special care shall be exercised in the bottom of slabs and girders to assure the working of the concrete around nests of reinforcing steel, so as to eliminate rock pockets or air bubbles. Enough rods, spades, tampers and vibrators shall be provided to compact each batch before the succeeding one is dumped and to prevent the formation of joints between batches.
- D. No concrete which has developed an initial set shall be used. Partially hardened concrete shall not be retempered or remixed.
- E. Placement of concrete shall only occur after reinforcement placement has been inspected and approved by the Engineer or their representative.
- F. The Engineer shall be notified of any concrete casting no later than 48 hours before any concrete pour.
- G. The forms shall be free of all ice and debris. No standing water shall be permitted inside of the forms.

**KOPACHUCK STATE PARK
DAY USE DEVELOPMENT**

- H. Vibrating shall be done along all faces to obtain smooth surfaces. Care shall be taken to prevent mortar from splattering on forms and reinforcing steel and from drying ahead of the final covering with concrete.
- I. Concrete shall not be placed in slabs or other sections requiring finishing on the top surface when precipitation is occurring or when in the opinion of the Engineer precipitation is likely before completion of the finishing, unless the Contractor shall have ready on the job all materials and equipment necessary to protect the concrete and allow finishing operations to be completed.
- J. Troughs, pipes, or short chutes used as aids in placing concrete shall be arranged and used in such a manner that the ingredients of the concrete do not become separated. Where steep slopes are required, troughs and chutes shall be equipped with baffle boards or shall be in short lengths that reverse the direction of movement. All chutes, troughs, and pipe shall be kept clean and free of hardened concrete by flushing thoroughly with water after each run. Water used for flushing shall be discharged clear of the concrete in place. Troughs and chutes shall be of steel or plastic or shall be lined with steel or plastic and shall extend as nearly as possible to the point of deposit. The use of aluminum for pipes, chutes or tremies is prohibited. When discharge must be intermittent, a hopper or other device for regulating the discharge shall be provided.
- K. Dropping the concrete a distance of more than 5 feet or depositing a large quantity at any point and running or working it along the forms will not be permitted. The placing of concrete shall be so regulated that the pressures caused by wet concrete shall not exceed those used in the design of the forms. Concrete shall not be dropped through reinforcing steel (as in walls) so as to cause segregation of aggregates. In such cases, hoppers and vertical chutes or trunks shall be used. Chutes or trunks shall of variable lengths so that free unconfined fall of concrete shall not exceed six feet. A sufficient number of chutes or trunks shall be used to ensure the concrete is kept level at all times.
- L. High frequency internal vibrators of either the pneumatic, electrical, or hydraulic type shall be used for compacting concrete in all structures. The number of vibrators used shall be ample to consolidate the fresh concrete within fifteen (15) minutes of placing in the forms. In all cases, the Contractor shall provide at least two concrete vibrators for each individual placement operation (one may be a standby), which shall conform to the requirements of these specifications. Prior to the placement of any concrete, the Contractor shall demonstrate that the two vibrators are in good working order and repair and ready for use.
- M. The vibrators shall be an approved type, with a minimum frequency of 5,000 cycles per minute and shall be capable of visibly affecting a properly designed mixture with a 1-inch slump for a distance of at least 18 inches from the vibrator.
- N. Vibrators shall not be held against forms or reinforcing steel nor shall they be used for flowing the concrete or spreading it into place. Vibrators shall be so manipulated as to produce concrete that is free of voids, is of proper texture on exposed faces, and of maximum consolidation. Vibrators shall not be held so long in one place as to result in segregation of concrete or formation of laitance on the surface.
- O. Concrete shall be placed continuously throughout each section of the structure or between indicated joints. If, in an emergency, it is necessary to stop placing concrete before a section is

**KOPACHUCK STATE PARK
DAY USE DEVELOPMENT**

completed, bulkheads shall be placed as the Engineer may direct and the resulting joint shall be treated as a construction joint.

- P. The presence of areas of excessive honeycomb may be considered sufficient cause for rejection of a structure. Upon written notice that a given structure has been rejected, the rejected work shall be removed and rebuilt, in part or wholly as specified, at the Contractor's expense.
- Q. Provide sleeves for all pipes through concrete walls and footings where shown on these drawings.
- R. See architect's plans for locations of slab slopes, depressions, curbs, drains, non-structural partitions and other embedded items not shown on the structural plans.

3.2 SAMPLING AND TESTING

- A. Third Party field tests of all concrete shall be performed by the City. Minimum testing shall consist of a unit weight test, slump test, and air-entrainment test for each delivery of concrete to the site, and three concrete cylinder compressive tests, two 28-day and one 7-day, for every 50 cubic yards or every three deliveries to the site, whichever will result in the least testing. The same test shall be required for prestressed concrete except that four compressive test cylinders shall be required, two release strength cylinders and two 28-day cylinders. All testing shall be performed under the provisions of ACI and ASTM. Compressive strength reports shall be submitted to the building department and E.O.R.
- B. Additional cylinders may be required, if an error in batching is suspected.
- C. Materials that fail to meet contract requirements, as indicated by laboratory tests, shall not be used in the Work. The Contractor shall remove all defective materials from the site.
- D. Types and sizes of concrete specimens shall be in accordance with ASTM C 31. Additional slump tests and/or test cylinders may be required at the discretion of the Engineer. Should the analysis of any test cylinder not meet the preceding requirements of Article 2.10, Composition of Concrete, its representative concrete shall be removed and replaced at the Contractor's expense.
- E. One hard copy, and one electronic copy via email, of all test reports shall be furnished to the Engineer.
- F. Measure slump prior to the addition of superplasticizers, where applicable.

3.3 PUMPING CONCRETE

- A. Concrete may be placed by pumping if the Contractor demonstrates that the pumping equipment to be used will effectively handle the particular class of concrete with the slump and air content specified and that it is so arranged that no vibrations result that might damage freshly placed concrete. The operation of the pump shall be such that a continuous stream of concrete without air pockets is produced.

**KOPACHUCK STATE PARK
DAY USE DEVELOPMENT**

- B. When pumping is completed, the concrete remaining in the pipeline, if it is to be used, shall be ejected in such a manner that there will be no contamination of the concrete or separation of the ingredients. After this operation, the entire equipment shall be thoroughly cleaned. Slump tests shall be taken at the discharge end of the pipe.

3.4 PLACING GROUT

- A. Prepare surface, and be clean and dust-free, leaving a non-carbonated substrate. Mix grout with manufacturer's recommended water quantity. Do not add additional water. Grout may be extended by adding up to 30 pounds of clean pea gravel per 50-pound bag of grout. Sample pea gravel shall be sent to grout manufacturer's lab for inspection and approval prior to use on the project.
- B. Avoid allowing air pockets to form while placing grout. Clean all spilled grout from deck surface immediately. Always flow grout in one direction while filling the keyways. Vacuum remove standing water encountered while grouting. Final surfaces shall be of uniform texture with surrounding concrete.

3.5 CONSTRUCTION JOINTS

- A. Construction joints shall be located where shown on the plans or as permitted by the Engineer. Construction joints shall be perpendicular to the principal lines of stress and in general shall be located at points of minimum shear.
- B. Construction joints shall have formed pour stops.
- C. Construction joints in walls and footings need not occur at the same location.
- D. At horizontal construction joints, gage strips 1-1/2 inches thick shall be placed inside the forms along all exposed faces to give the joints straight lines. Before placing fresh concrete, the surfaces of construction joints shall be washed and scrubbed with a wire broom, drenched with water until saturated, and kept saturated until the new concrete is placed.
- E. Immediately prior to placing new concrete the forms shall be drawn tight against the concrete already in place. Concrete in substructures shall be placed in such manner that all horizontal construction joints will be truly horizontal and, if possible, in locations such that they will not be exposed to view in the finished structure. Where vertical construction joints are necessary, reinforcing bars shall extend across the joint in such a manner as to make the structure monolithic. Special care shall be taken to avoid construction joints through large surfaces which are to be treated architecturally.
- F. All construction joints shall be provided with concrete shear keys at least 1-1/2 inches deep and 1/3 of the concrete thickness in width, unless otherwise shown on the plans.

3.6 CRACK CONTROL JOINTS

- A. Crack Control Joints shall be installed as shown on the Drawings or where designated by the Engineer.

**KOPACHUCK STATE PARK
DAY USE DEVELOPMENT**

- B. Crack control joints shall be spaced at 5 feet on center, if not specified otherwise on the plans.
- C. Crack Control Joints shall be straight and true. Crack Control Joints shall have a formed crack a minimum of $\frac{1}{4}$ of the concrete thickness and may be formed using a plastic strip anchored to the form or other method approved by the Engineer. Slabs may be saw cut $\frac{1}{4}$ of the concrete thickness before curing.
- D. Construction joints shall be cleaned and roughened by removing the entire surface to expose clean aggregate solidly embedded in the mortar matrix. Slush with a coat of neat cement before placing concrete. See plans and details for location and type of construction joint. Locations of additional construction joints not shown on these plans shall be submitted for approval by the E.O.R. prior to placing any concrete.

3.7 EXPANSION JOINTS

- A. Full depth expansion joints shall be spaced at a minimum interval of 30 feet on center, with a half depth expansion joint at 15 feet intervals between full depth expansion joints.
- B. Open Joints. Open joints shall be placed in the location shown on the plans and shall be formed. The form shall be removed without chipping or breaking the corners of the concrete. Reinforcement shall not extend across an open joint, unless so specified on the plans.
- C. Filled Joints. Unless otherwise shown on the plans, expansion joints shall be constructed with pre-molded expansion joint filler with a thickness equal to the width of the joint.
- D. The joint filler shall be cut to the same shape and size as the adjoining surfaces. It shall be fixed firmly against the surface of the concrete already in place in such manner that it will not be displaced when concrete is deposited against it.
- E. Immediately after the forms are removed, the expansion joints shall be inspected carefully. Any concrete or mortar that has sealed across the joint shall be removed.
- F. Joint sealer for use in deck joints shall be of the type shown on the plans conforming to the requirements of Article 2.4 – Joint Fillers, of this Section. The faces of all joints to be sealed shall be free of foreign matter, paint, curing compound, oils, greases, dirt, free water, and laitance.
- G. Steel Joints
 - 1. The plates, angles, or other structural shapes shall be accurately shaped at the shop to conform to the section of the concrete slab. The fabrication and painting shall conform to the requirements of the specifications covering those items. Care shall be taken to insure that the surface in the finished plane is true and free of warping. Positive methods shall be employed in placing the joints to keep them in correct position during the placing of the concrete. The opening at expansion joints shall be that designated on the plans at normal temperature.

**KOPACHUCK STATE PARK
DAY USE DEVELOPMENT**

3.8 FINISHING CONCRETE SURFACES

- A. All Joints shall be edged with a quarter-inch (1/4") radius edger, and sidewalk edges with a half-inch (1/2") radius edger as directed by the Project Engineer in the field.
- B. After striking off and consolidating concrete, smooth surface by screening and floating. Use hand methods only where mechanical floating is not possible. Adjust floating to compact surface irregularities, and refloat repaired area to provide a continuous smooth finish.
- C. Ordinary Finish
 - 1. An Ordinary Finish is defined as the finish left on a surface after the removal of the forms, the filling of all holes left by form ties, and the repairing of all defects. The surface shall be true and even, free from stone pockets and depressions or projections. All surfaces that cannot be satisfactorily repaired shall be given a Rubbed Finish.
- D. Unfinished
 - 1. An unfinished surface is defined as the surface that bears against soil and is not visible. No finishing work is required.
- E. All concrete surfaces shall be finished according to the following:

Location	Concrete Finish
Concrete Hardscaping	Medium Broom
Soil side of retaining walls	Unfinished
Exposed Face of Retaining Walls	Board Forms

- F. As soon as the forms are removed, metal devices that have been used for holding the forms in place, and which pass through the body of the concrete, shall be removed or cut back at least 1-inch beneath the surface of the concrete. Fins of mortar and all irregularities caused by form joints shall be removed.
- G. All small holes, depressions, and voids that show upon the removal of forms shall be filled with cement mortar mixed in the same proportions as that used in the body of the work. In patching larger holes and honeycombs, all coarse or broken material shall be chipped away until a dense uniform surface of concrete exposing solid coarse aggregate is obtained. Feathered edges shall be cut away to form faces perpendicular to the surface. All surfaces of the cavity shall be saturated thoroughly with water, after which a thin layer of neat cement mortar shall be applied. The cavity shall then be filled with stiff mortar composed of one part of Portland cement to two parts of sand, which shall be thoroughly tamped into place. The mortar shall be pre-shrunk by mixing it approximately 20 minutes before using. The length of time may be varied in accordance with brand of cement used, temperature, humidity, and other local conditions. The surface of this mortar shall be floated with a wooden float before initial set takes place and shall be neat in appearance. The patch shall be kept wet for a period of five days.
- H. For patching large or deep areas, coarse aggregate shall be added to the patching material. All mortar for patching on surfaces which will be exposed to view in the completed structure shall

**KOPACHUCK STATE PARK
DAY USE DEVELOPMENT**

be color matched to the concrete. Test patches for color matching shall be conducted on concrete that will be hidden from view in the completed work and shall be subject to approval.

3.9 COLD WEATHER CONCRETE AND CONCRETE CURING

- A. Maintain concrete above 50 degrees Fahrenheit and in a moist condition for a minimum of 7 days after placement unless otherwise accepted by the Engineer.
- B. Concrete shall not be placed when the descending air temperature in the shade, away from artificial heat, falls below 40 degrees Fahrenheit nor resumed before the ascending air temperature reaches 35 degrees Fahrenheit, without specific written authorization. When the air temperature falls below 40 degrees Fahrenheit, or is, in the opinion of the Engineer, likely to do so within a 24-hour period after placing concrete, the Contractor shall have ready on the job materials and equipment required to heat mixing water and aggregate and to protect freshly placed concrete from freezing.
- C. Concrete placed at air temperatures below 40 degrees Fahrenheit shall have a temperature not less than 50 degrees Fahrenheit nor greater than 70 degrees Fahrenheit when placed in the forms. These temperatures shall be obtained by heating the mixing water and/or aggregate. Mixing water shall not be heated to more than 160 degrees Fahrenheit.
- D. Binned aggregates containing ice or in a frozen condition will not be permitted nor will aggregates which have been heated directly by gas or oil flame or heated on sheet metal over an open fire. When aggregates are heated in bins, only steam coil or water coil heating will be permitted, except that other methods, when approved, may be used. If live steam is used to thaw frozen aggregate piles, drainage times comparable to those applicable for washed aggregates shall apply.
- E. When the temperature of either the water or aggregate exceeds 100 degrees Fahrenheit, they shall be mixed together so that the temperature of the mix does not exceed 80 degrees Fahrenheit at the time the cement is added.
- F. When placing concrete in cold weather, the following precautions shall be taken in addition to the above requirements:
 - 1. Heat shall be applied to forms and reinforcing steel before placing concrete as required to remove all frost, ice, and snow from all surfaces which will be in contact with fresh concrete.
 - 2. When fresh concrete is to be placed in contact with hardened concrete, the surface of the previous pour shall be warmed to at least 35 degrees Fahrenheit, thoroughly wet, and free water removed before fresh concrete is placed.
 - 3. Freshly placed concrete shall be maintained at a temperature of not less than 70 degrees Fahrenheit for three (3) days or not less than 50 degrees Fahrenheit for five (5) days, when Type I or II cement is used, and not less than 70 degrees Fahrenheit for two (2) days or not less than 50 degrees Fahrenheit for three (3) days, when Type III cement is used. The above requirements are not intended to apply during the normal summer construction season when air temperatures of 40 degrees Fahrenheit or higher can reasonably be anticipated during the two week period immediately following concrete placement, or until the concrete is no longer in danger from freezing.

**KOPACHUCK STATE PARK
DAY USE DEVELOPMENT**

- G. When temperatures below 20 degrees Fahrenheit are not expected during the curing period and, in the opinion of the Engineer, no other adverse conditions, such as high winds, are expected, concrete temperatures may be maintained in thick concrete sections by retention of heat of hydration by means of adequately insulated forms.
- H. When, in the opinion of the Engineer, greater protection is required to maintain the specified temperature, the fresh concrete shall be completely enclosed and an adequate heat source provided. Such enclosure and heat source shall be so designed that evaporation of moisture from the concrete during curing is prevented. Precautions shall be taken to protect the structure from overheating and fire.
- I. At the end of the required curing period protection may be removed, but in such a manner that the drop in temperature of any portion of the concrete will be gradual and not exceed 30 degrees Fahrenheit in the first 24 hours.
- J. For concrete placed within cofferdams and cured by flooding with water, the above conditions may be waived provided that the water in contact with the concrete is not permitted to freeze. Dewatering shall not be carried out until the Engineer determines that the concrete has cured sufficiently to withstand freezing temperatures and hydrostatic pressure.
- K. The Contractor shall be wholly responsible for the protection of the concrete during cold weather operations. Any concrete injured by frost action or overheating shall be removed and replaced at the Contractor's expense.

3.10 CURING COMPOUND

- A. Curing compound used on concrete that is to receive finishes shall be compatible with tile and adhesives or grouts in accordance with manufactures data and be approved for use.

3.11 BACKFILLING AND PROTECTION AGAINST LOADS

- A. Prior to erecting any elements that load the foundation, concrete must reach an unconfined compression strength of 2000 psi minimum as determined by testing or previously documented data for the mix design used under similar conditions, and must be allowed to cure for a minimum of 3 days.
- B. Backfilling against concrete structures shall comply with the requirements of the table below:

Age of Concrete	Backfill Height
72 hours	1/2 Wall Height
7 Days	2/3 Wall Height
28 Days	Full Wall Height

3.12 ANTI-GRAFFITI COATING

**KOPACHUCK STATE PARK
DAY USE DEVELOPMENT**

- A. Apply anti-graffiti coating to all exterior cast-in-place concrete surfaces.
- B. Anti-graffiti coatings shall be applied per manufacturer's recommendations.
- C. Anti-graffiti coating shall not be applied until concrete has been allowed to cure for a minimum of 28 days.

3.13 CONCRETE ANCHORS

- A. All drilled installation epoxy anchors and wedge anchors shall be installed per manufactures recommendations.

3.14 CLEANUP

- A. Upon completion of the structure and before final acceptance, the Contractor shall remove all falsework.

3.15 CORE DRILLING

- A. Coring is not permitted without prior approval by the E.O.R.
- B. Core drills required shall not cut any reinforcing. The contractor is to coordinate work of all trades to ensure compliance. All core drills are to be presented to the Engineer of Record for verification. The Engineer of Record is to document cores examined indicating an absence of reinforcing.

3.16 SPECIAL INSPECTIONS

- A. The following elements are to be special inspected. See Section 014000 – Quality Requirements for additional special inspection requirements.
- B. Continuous:
 - 1. Sampling fresh concrete and performing slump and air content tests and determining the temperature of fresh concrete at the time of making specimens for strength tests.
 - 2. Inspection of concrete placement for proper application techniques.
- C. Periodic
 - 1. Verify use of required mix design.
 - 2. Inspection for maintenance of specified curing temperature and technique.
 - 3. Verification of in-situ concrete strength, prior to removal of shores and forms from beams and structural slabs.
 - 4. Inspect post-installed and adhesive anchors.

END OF SECTION 321313

**KOPACHUCK STATE PARK
DAY USE DEVELOPMENT**

SECTION 321613 – CAST-IN-PLACE CONCRETE CURB AND GUTTER

1.1 RELATED DOCUMENTS

- A. Drawings and general provisions of the Contract, including General Conditions and Division 1 Specification Sections, apply to this Section.

1.2 SUMMARY

- A. This Section includes:
 - 1. Wheel chair ramp.
 - 2. Concrete Curb & Gutter.
 - 3. Concrete Curb.
- B. Concrete curb contractor to attend a pre-construction meeting with the general contractor and Owner's Representative prior to mobilizing.

1.3 RELATED WORK SPECIFIED ELSEWHERE

- A. Section 310000 – Earthwork
- B. Section 321216 – Asphalt Concrete Pavement and Pavement Marking
- C. Section 321313 – Cast-in-Place Concrete

PART 2 - MATERIALS

2.1 GENERAL

- A. Concrete and finish shall be same as concrete (concrete pavement). (See Section 321313 Cast-in-Place Concrete)

2.2 EXPANSION JOINTS

- A. Premolded expansion joint filler shall be of sufficient size to cover the full depth of the concrete section. Joints shall be 3/8" thick.

2.3 CAST-IN-PLACE CONCRETE CURBS

- A. Shall be constructed in accordance with Section 8-04 of the WSDOT/APWA Standard Specifications.

**KOPACHUCK STATE PARK
DAY USE DEVELOPMENT**

2.4 ACCESS RAMP/WHEELCHAIR RAMP

- A. Construct as detailed.
- B. Provide ADA textured truncated dome detectable warning pattern.

2.5 REINFORCING BARS

- A. Grade 60, #4 typical, tie with No. 16 double annealed wire.

PART 3 - EXECUTION

3.1 CURB & GUTTERS / CURBS

- A. Verify that the subgrade is completed to correct line and grade before starting work.
- B. The subbase for curb sections shall be compacted to ninety-five percent (95%) of maximum dry density as determined by the ASTM test method D-698 standard proctor before placing the curb.
- C. White pigmented curing compounds will not be allowed.
- D. The top of the finished concrete shall not deviate more than one-eighth inch (1/8") in ten feet (10'), or the alignment on-fourth inch (1/4") in ten feet (10').

Note: All radii shall be formed with flexible form sections to conform to the radii shown. Rigid, straight steel sections are not allowed even in forming the large radii.

- E. Joints shall be at a maximum spacing of ten feet (10'); with expansion joints at beginning of curbs, curb returns, and wheelchair ramps. NOTE: Coordinate joints in adjacent sidewalk.
- F. Broom finish the top and face parallel with the curb length.

3.2 ACCESS RAMP/WHEELCHAIR RAMP

- A. Ramps: Construct as detailed and provide ADA textured truncated dome detectable warning pattern.

END OF SECTION 321613

**KOPACHUCK STATE PARK
DAY USE DEVELOPMENT**

SECTION 323915 – SITE FURNISHINGS

PART 1 - GENERAL

1.1 RELATED DOCUMENTS

- A. Drawings and general provisions of the Contract, including General Conditions and Division 1 Specification Sections, apply to this Section.

1.2 SUMMARY

- A. This Section includes the following site and street furnishings:

1. Sanitary Yard Hydrant
2. Grate for Sanitary Yard Hydrant
3. Playground Farm Pump
4. Park Grill
5. Bike Rack
6. Bollards
7. Flagpole
8. Slide
9. Rope Climber
10. Picnic Tables

- B. Related Sections include the following:

1. Section 310000 – Earthwork for excavation for installation of concrete footings.
2. Section 321313 – Cast-in-Place Concrete for concrete footings.
3. Section 323916 – Playground Surfacing and Crushed Rock Paths.
4. Products under this Section, include base plates and anchor bolts to be cast in concrete footings.

1.3 SUBMITTALS

- A. Product Data: For each type of product indicated. Include construction details, material descriptions, dimensions of individual components and profiles, finishes, field-assembly requirements, and installation details.
- B. Samples for Initial Selection: For units with factory-applied color finishes.
- C. Product Schedule: For site furnishings. Use same designations indicated on Drawings.

1.4 QUALITY ASSURANCE

- A. Source Limitations: Obtain each type of site furnishings through one source from a single manufacturer.

**KOPACHUCK STATE PARK
DAY USE DEVELOPMENT**

PART 2 - PRODUCTS

2.1 MANUFACTURERS

- A. Available Products: Subject to compliance with requirements, products that may be incorporated into the Work include, but are not limited to, the following:
- B. Products: Subject to compliance with requirements.

2.2 SANITARY YARD HYDRANT

- A. Description:
 - 1. Hose connection backflow preventer (BFP).
 - 2. ASSE 1052 approved.
 - 3. Field testable.
 - 4. Two check valves.
 - 5. With optional ASSE 1057 listed vacuum breaker.
 - 6. ADA compliant – meets ADA requirements for height and 5 lbs max operating force.
 - 7. Female Inlet: 1" NPT.
 - 8. Finish: Painted Forest Service Brown.
- B. Quantity:
 - 1. One (1).
- C. Approved Manufacturer (Product):
 - 1. Woodford backflow protected automatic draining, freeze less, self-closing sanitary yard hydrant Model S4H.

2.3 GRATE AT SANITARY YARD HYDRANT

- A. Description: Tree grate "cover" at sanitary yard hydrant.
 - 1. ADA accessible, "Rainbow" style.
 - 2. Size: 6' round with frame.
 - 3. Ductile iron, raw natural finish.
 - 4. Urban Accessories or approved equal.

- B. Quantity: One (1)

2.4 PLAYGROUND FARM PUMP

- A. Description:
 - 1. Farm pump for direct connection to pressure line.
 - 2. Flow rate .51 1/8 gallon per stroke.

**KOPACHUCK STATE PARK
DAY USE DEVELOPMENT**

3. Gray cast iron painted green (RAL 6005) with 1¾" stand
Provide all fittings as required and operating system.

B. Approved Product: Goric GP460 (SD 75), 617-744-0772 or approved equal.

C. Quantity: One (1)

2.5 PARK GRILL

A. Description: Kay Park Model SPD450.

B. Quantity: See contract drawings.

C. Mount: In-ground mount.

2.6 BIKE RACK

A. Description:

1. 2" (minimum) Schedule 40 conforming to ASTM A53, 5 loop wave style, 7 bike capacity.
2. Coating: Hot dip galvanized to standard ASTM A123, A123M, 3 to 4 mils thick polyester or polyester TGIC powder, 4 mils thick.
3. Pipe Collar: Steel one piece, powder coated to match pipe.
4. Fairweather BR1.7 5-Loop or approved equal.

B. Color: Park Brown.

C. Mount: In ground.

D. Quantity: One (1)

2.7 BOLLARDS

A. See drawings.

2.8 FLAGPOLE

A. Description: Aluminum flagpole shall meet the following:

1. Pole Height Above Ground: 40'.
2. Butt Diameter: 7".
3. Top Diameter: 3.5".
4. Wall Thickness: .188".
5. Ball Diameter: 7".
6. Options:

- a. Internal Halyard – Roped System:

**KOPACHUCK STATE PARK
DAY USE DEVELOPMENT**

- 1) 5/16" fully braided white nylon halyard line.
- 2) #2 brass swivel snaps.
- 3) 7: + ID retainer ring.
- 4) 7: L white plastic coated counterweight.
- 5) Internal heavy-duty jamb cleat.

B. Color: Clear anodized.

C. Product: Fabricate from seamless extruded tubing, complying with ASTM-B241, alloy 6062-T6, tensile strength not less than 30,000 psi and a yield point of 25,000 psi. Heat treat and age harden after fabrication.

D. Quantity: One (1).

2.9 SLIDE

A. Description:

1. Materials:

- a. Die Cast Alloy Clamp: 413. Aluminum alloy.
- b. Rotomolded Slide: Low density polyethylene.
- c. Rail: Galvanized steel tubing.
- d. Exit Support Post: 2.38 in, 12 ga.
- e. Handle Casting: 319 aluminum alloy.
- f. Slide Canopy: Low density polyethylene.

B. Color: Brown

C. Approved Product: Playworld Nautical Slither Slide, side entry, 72" deck height.

D. Quantity: One (1).

2.10 ROPE CLIMBER

A. Description:

1. Materials:

- a. Hand-woven 11 ½" mesh square cargo climb with a 10" mesh opening, 1 ½" NU-Line Rope.
- b. Includes 3/8" NU-Line Rope for lacing, #96 Netting for back up net, and twine to attach the backup net to cargo climb.

B. Approved Product: Nets Unlimited, Inc. (480) 515-1300.

C. Quantity: One (1).

**KOPACHUCK STATE PARK
DAY USE DEVELOPMENT**

2.11 PICNIC TABLES

- A. Description: Owner furnished; Contractor installed.

PART 3 - EXECUTION

3.1 EXAMINATION

- A. Examine areas and conditions, with Installer present, for compliance with requirements for correct and level finished grade, mounting surfaces, installation tolerances, and other conditions affecting performance.
- B. Proceed with installation only after unsatisfactory conditions have been corrected.

3.2 INSTALLATION, GENERAL

- A. Comply with manufacturer's written installation instructions, unless more stringent requirements are indicated. Complete field assembly of site furnishings, where required.
- B. Install site furnishings level, plumb, true, and securely anchored at locations indicated on Drawings.

3.3 CLEANING

- A. After completing site-furnishing installation, inspect components. Remove spots, dirt, and debris. Repair damaged finishes to match original finish or replace component.

END OF SECTION 323915

**KOPACHUCK STATE PARK
DAY USE DEVELOPMENT**

SECTION 323916 – PLAYGROUND SURFACING AND CRUSHED ROCK PATHS

PART 1 - GENERAL

1.1 RELATED DOCUMENTS

- A. Drawings and general provisions of the Contract, including General Conditions and Division 1 Specification Sections, apply to this Section.

1.2 SUMMARY

- A. This section includes the following:
 - 1. Accessible engineered wood fiber playground safety surfacing system.
 - 2. Play sand.
 - 3. Crushed rock path/trail and pre-cast concrete steps.
- B. Related sections include:
 - 1. Section 310000 – Earthwork for nonwoven geotextile fabric
 - 2. Section 321313 – Cast-In-Place Concrete for crushed rock base

1.3 SUBMITTALS

- A. Engineered Wood Fiber: product data sheet and 1/2 cubic foot sample.
- B. Geotextile Fabric: product data sheet and 12" x 12" sample.
- C. Play Sand: 1/4 cubic foot sample and sieve analysis.
- D. Pea Gravel Base: 1/4 cubic foot sample and sieve analysis.
- E. One quarter inch (1/4") minus crushed rock: 1/4 cubic foot sample and sieve analysis.
- F. Precast concrete landscape steps: product data sheet.
- G. Written Warranty:
 - 1. Engineered Wood Fiber
- H. GMax Test Results:
 - 1. Engineered Wood Fiber
- I. Quality Assurance Certificates.
 - 1. Engineered Wood Fiber

**KOPACHUCK STATE PARK
DAY USE DEVELOPMENT**

- J. Maintenance Instructions.
 - 1. Engineered Wood Fiber
 - 2. 1/4 minus crushed rock path/trail

1.4 QUALITY ASSURANCE

- A. Engineered Wood Fiber:
 - 1. Manufacturer shall provide impact test results in accordance with current ASTM F1292 Standard Specification for Impact Attenuation of Surface Systems Under and Around Playground Equipment. Test results must show 12' drop test GMax values of less than 155g, and less than 100 HIC.
 - 2. Safety surfacing product must have current IPEMA (International Playground Equipment Manufacturer's Association) testing and certification to be considered in compliance with ASTM F1292 standards. Validation is available at www.impema.org.
 - 3. Manufacturer must provide proof of ADA accessibility in accordance with ASTM F1951 Standard Specification for Determination of Accessibility of Surface Systems Under and Around Playground Equipment.
 - 4. Manufacturer must provide proof of compliance with ASTM F2075 Standard for Engineered Wood Fiber for Surface Systems Under and Around Playground Equipment.
 - 5. Minimum manufacture's performance warranty: 15 years.

PART 2 - PRODUCTS

2.1 MATERIALS

- A. Engineered Wood Fiber: GT-MPAX (or approved equal), manufacturer: GameTime 800-235-2440), available from SiteLines Park and Playground Products 800-541-0869. Engineered wood fiber shall be a mix of random-sized Cedar blend of wood particles that have been ground and screened specifically for use as a playground safety surface. Material shall be free from bark, dirt, leaves, or other contaminants, with interlocking fibers that make a matrix capable of supporting wheelchairs, and other assistive devices. Hardwood material will not be considered, due to the susceptibility to decay.
 - 1. Provide and install approximately 33% additional material to allow for compaction; depth after 30 day compaction period shall be 12" minimum.
 - 2. Install (1) layer of geotextile beneath wood fiber surfacing, overlapping edges at least 4".
 - a. GameTime Impaxfelt polyester geotextile or approved equal.
- B. Play Sand: Play Sand shall be a high quality washed sand.
- C. Crushed Rock Base: See Section 321313 – Cast-in-Place Concrete.

**KOPACHUCK STATE PARK
DAY USE DEVELOPMENT**

- D. Crushed Rock path/trails: One quarter inch (1/4") minus shall meet the following specification:

<u>Sieve</u>	<u>% Passing</u>
1/4"	100
#10	40-75
#200	10-15

- E. Precast concrete landscape steps:

1. 4' x 18" x 6" precast concrete.
2. Color: Grey.
3. Available from: Morrison Gravel, Inc, (360) 876-4701.

PART 3 - EXECUTION

3.1 INSTALLATION

- A. Install engineered wood fiber safety surfacing system in accordance with manufacturer's standard installation instructions to the compaction depth shown.
- B. Install play sand to depth shown on the drawings.
- C. Rock base as detailed.
- D. Crushed rock path/trails as detailed.
- E. Precast concrete landscape steps, construct as detailed.

3.2 MAINTENANCE

- A. Provide onsite instructions to the owner's maintenance staff and written maintenance instructions.

END OF SECTION 323916

**KOPACHUCK STATE PARK
DAY USE DEVELOPMENT**

SECTION 329113 – SOIL MIXES & PLACEMENT

PART 1 - GENERAL

1.1 RELATED DOCUMENTS

- A. Drawings and general provisions of the Contract, including General Conditions and Division 1 Specifications, apply to this Section.

1.2 SECTION INCLUDES

- A. Subgrade preparation.
- B. Soil for planting and seeded areas.

1.3 SUMMARY

- A. Related Work in other sections of these specifications includes, but is not limited to:
 - 1. Section 329200 – Seeding
 - 2. Section 329300 – Planting

1.4 REFERENCES

- A. ASTM D 1557: Method for Laboratory Compaction Characteristics of Soil using Modified Effort.

1.5 DEFINITIONS

- A. Percent Compaction: The required in-place dry density of the material, expressed as a percentage of the maximum dry density of the same material determined by ASTM D1557-78 test procedure.
- B. Soil Subgrade: The soil surface on which compost material is placed.
- C. Finished Grades: The final grade elevations indicated on the Grading Drawings.
- D. Aesthetic Acceptance of Grades: Acceptance by the Owner's Representative in writing of the Aesthetic Correctness of the contours as observed without a survey instrument. Aesthetic Acceptance does not address whether an area drains properly, whether the areas are at the correct elevation, or whether it has been compacted properly.
- E. Acceptance: Wherever the terms "acceptance" or "accepted" are used herein, they mean acceptance of Owner's Representative in writing.

**KOPACHUCK STATE PARK
DAY USE DEVELOPMENT**

- F. Grading Drawings: Plans, sections, and profiles showing finished surface grades.
- G. Elements with Fixed Elevations: Paths, paving, concrete pads, headers, footings, foundations, walls, and other structures with fixed-spot elevations.

1.6 SUBMITTALS

- A. Submit product data and one-gallon sample of compost and loamy sand. Submit in accordance with Section 013300 - Submittal Procedures.

1.7 SITE CONDITIONS

- A. Environmental Protection:
 - 1. Soil Moisture Content: Do not work soil when moisture content is so great that excessive compaction will occur, nor when it is so dry that dust will form in air or that clods will not break readily.

PART 2 - PRODUCTS

2.1 MATERIAL

- A. Compost: Well-composted, stable, and weed-free organic matter, pH range of 5.5 soluble salt content of 5 to 10 decisiemens/m; not exceeding 0.5 percent inert contaminants and free of substances toxic to plantings; and as follows:
 - 1. Organic Matter Content: 50% to 60% of dry weight.
 - 2. Feedstock: Agricultural, food, or industrial residuals; biosolids; yard trimmings; or source-separated or compostable mixed solid waste.
- B. Loamy Sand: Weed free loamy sand screened through a 3/8" screen.

PART 3 - EXECUTION

3.1 EXAMINATION

- A. Subgrade:
 - 1. Verification: Verify that the subgrades have been graded to within one tenth of a foot of the grades shown on the grading Drawings.
 - 2. Aesthetic Acceptance: Verify that Owner's Representative has given the subgrade aesthetic acceptance. Do not place compost material or rototill material into subgrade until Owner's Representative has accepted subgrade for aesthetic correctness.
 - 3. Notification of Discrepancies: Notify the Owner's Representative in writing of any discrepancies.

**KOPACHUCK STATE PARK
DAY USE DEVELOPMENT**

3.2 SOIL PLACEMENT

- A. Place soil as detailed on the plans.
- B. **BMP (Shrub Areas)**
 - 1. After stripping forest duff and grading to finish subgrade obtain approval of finish subgrade.
 - 2. Place three (3) inches of compost and till into 8" depth of subgrade or 6" below bottom of specified plants, whichever is greater.
 - 3. Pit plant shrubs.
 - 4. Provide 2" mulch as detailed.
- C. **BMP (Seeded Areas)**
 - 1. Place 4" of 30% compost and 70% loamy sand over "approved" finish subgrade.
 - 2. Seed.

3.3 FOLLOW UP

- A. Spillage:
 - 1. Take precautions to prevent spillage when hauling on or adjacent to any public street or highway.
 - 2. In the event that spillage occurs, remove all spillage and sweep, wash, or otherwise clean such streets or highways as required by County or State authorities.
- B. Dust Control: Use water trucks or temporary irrigation and take all precautions needed to prevent a dust nuisance to adjacent public or private properties.
- C. Erosion:
 - 1. Correct erosion and siltation damage at no cost to the Owner.
- D. Settlement Repair: Correct settlement within the Warranty period at no cost to the Owner.

3.4 CLEANUP

- A. Daily: Keep all areas of Work clean, neat, and orderly at all times.
- B. Final: Clean up and remove all deleterious materials and debris from the entire Work area prior to Final Completion.

END OF SECTION 329113

**KOPACHUCK STATE PARK
DAY USE DEVELOPMENT**

SECTION 329200 – SEEDING

PART 1 - GENERAL

1.1 RELATED DOCUMENTS

- A. Drawings and general provisions of the Contract, including General Conditions and Division 1 Specification Sections, apply to this Section.

1.2 SUMMARY

- A. This Section includes the following:
 - 1. Seeding areas where shown and any exposed soil caused by construction that is not planted.
- B. Related Sections include the following:
 - 1. Section 329113 – Soil Mixes and Placement.
 - 2. Section 329300 – Planting.

1.3 DEFINITIONS

- A. Finish Grade: Elevation of finished surface of soil.

1.4 QUALITY ASSURANCE

- A. Installer Qualifications: A qualified landscape installer whose work has resulted in successful grass establishment.
 - 1. Installer's Field Supervision: Require Installer to maintain an experienced full-time supervisor on project site when planting is in progress.
- B. Pre-Installation Conference: Conduct a conference at project site to comply with requirements in Division 1.

1.5 SUBMITTALS

- A. Seed Analysis: A complete analysis of the seed shall be submitted by the Contractor prior to planting. The analysis shall include: the percent of pure seed, germination rate, other crop seed (including inert and weed seed), and the germination test date. All crop seed in excess of one percent must be itemized.
- B. Fertilizer Certification: Submit duplicate copies of all invoices for all fertilizer showing the grade furnished.

**KOPACHUCK STATE PARK
DAY USE DEVELOPMENT**

C. Schedule: Maintenance shall be continuous until the project as a whole is accepted.

PART 2 - PRODUCTS

2.1 SEED

A. Pierce County Table 3.4 Low-Growing Turf Seed Mix:

1.

	% Weight	% Purity	% Germination
Dwarf tall fescue (several varieties) (<i>Festuca arundinacea</i> var.)	45	98	90
Dwarf perennial rye (Barclay) (<i>Lolium perenne</i> var. Barclay)	30	98	90
Red fescue (<i>Festuca rubra</i>)	20	98	90
Colonial bentgrass (<i>Agrostis tenuis</i>)	5	98	90

B. Other Seed Requirements:

1. Seed Law: All seeds shall conform to the requirements of the Washington State Seed Laws, and where applicable, the Federal Seed Act.
2. Noxious Weed Seed: All seed shall be free of seeds of weeds listed as primary noxious by the Washington State Seed Law. Seeds shall not contain seeds of weeds listed as secondary noxious by the Washington State Seed Law, singly or collectively in excess of the labeling tolerance specified by the Washington State Seed Law.
3. Rejection: When seeds furnished under this specification fail to meet the requirements within tolerance, as provided by the Washington State Seed Law, the lot shall be rejected or subjected to fiscal adjustment.
4. Re-cleaning: Seeds shall be thoroughly re-cleaned and of uniformly good quality and appearance throughout each lot.
5. Preparation for Delivery: Seeds shall be packed in clean, sound containers of uniform weight. Seed shall be labeled as required by law.
6. Reference Specifications: Chapter 15.49, Washington State Seed Law.

**KOPACHUCK STATE PARK
DAY USE DEVELOPMENT**

2.2 FERTILIZER

A. For Incorporation with Seeding:

1. Initial Application:

- a. Use a 10-20-20 or 16-16-16 fertilizer with the following characteristics:
 - 1) 50% of the nitrogen shall be derived from 38% urea formaldehyde.
 - 2) Potash shall be derived from sulfate of potash.
 - 3) Fertilizer shall be retained by Taylor standard sieves as follows:
 - a) No. 4 sieve retains 0%.
 - b) No. 20 sieve retains 65%.
 - c) No. 80 sieve retains 95%.
- b. Preparation for Delivery: Fertilizer shall be packaged in new, waterproof, fifty pound (50 lb) bags, clearly labeled as to weight, manufacturer, and content.

2.3 MULCH FOR HYDROSEEDING

- A. Hydroseed mulch shall be 100% wood fiber mulch manufactured by the defibrating process, from fir, hemlock, or alder. The mulch shall have a minimum of 60% of fibers 8.5 mm or longer and 77% of the total fiber exceeding 3.5 mm in length.
- B. Wood fiber mulch shall be in uniform weight displayed clearly on each package. Fiber shall be dyed green in color to provide visual metering of application. Tackifier shall be incorporated in to the wood fiber I the drying process. Percentage of tackifier shall not be les than 2% or greater than 10%, with the percentage used clearly labeled on outside of package.

2.4 TACKIFIER

- A. Tackifier to be primarily composed of guar gum.
- B. Tackifier shall be incorporated into the wood fiber in the drying process.
- C. Percentage of tackifier shall not be less than 2% or greater than 10%, with the percentage used clearly labeled on the outside of package.
- D. Tackifier rates shall be adjusted by adding wood fiber mulch with tackifier and regular wood fiber mulch to provide tackifier rates equivalent to or greater than specified.

PART 3 - EXECUTION

3.1 EXAMINATION

- A. Examine areas to receive seeding for compliance with requirements and other conditions affecting performance. Verify finish subgrade is correct before beginning work. Proceed with installation only after unsatisfactory conditions have been corrected.

**KOPACHUCK STATE PARK
DAY USE DEVELOPMENT**

3.2 PREPARATION

- A. Protect structures, utilities, sidewalks, pavements, and other facilities, trees, shrubs, and plantings from damage caused by planting operations.
 - 1. Protect adjacent and adjoining areas from hydro seeding over spray.
- B. Provide erosion-control measures to prevent erosion or displacement of soils and discharge of soil-bearing water runoff or airborne dust to adjacent properties and walkways.

3.3 PREPARATION

- A. Limit finish grade preparation to areas to be planted.
- B. Newly Graded Finish Grades: Loosen soil to a minimum depth of 4". Remove stones larger than 2" in any dimension and sticks, roots, rubbish, and other extraneous matter and legally dispose of them off Owner's property.

3.4 HYDROSEEDING

- A. Hydroseeding: After finished grading is complete and approved, apply seed, fertilizer and mulch in one operation by an approved hydroseeder, which utilizes water as the carrying agency and maintains a continuous agitator action that will keep seed and fiber in homogeneously mixed slurry until pumped from tank. Distribution and discharge lines must be large enough to prevent stoppage and must be equipped with a set of hydraulic discharge spray nozzles, which will provide a uniform distribution of the slurry. All spill over on equipment, pavement, trees, etc. shall be immediately cleaned off.
- B. Application Rates:
 - 1. Seed: 6.9 lbs. per 1,000 sf.
 - 2. 10-20-20 or 16-16-16 Fertilizer: 15 lbs. per 1,000 sf.
 - 3. Mulch: 46 lbs. per 1,000 sf.
 - 4. Tackifier: 1 lb. per 1,000 sf.

3.5 MOWING LAWN AREAS

- A. Grass shall be mowed a minimum of one time before acceptance. The mowing shall occur when the grass first reaches two inches (2") in height and then be mowed to a height of one and one half inches (1½"). Mowing shall continue on a weekly basis thereafter until all the grass areas or the project as a whole is accepted by the Owner.

3.6 MAINTENANCE

- A. The maintenance of all lawn areas shall include watering, weed treatment, and mowing. Maintenance shall continue until the project is accepted.

**KOPACHUCK STATE PARK
DAY USE DEVELOPMENT**

3.7 RESEEDING OF BARE OR SPARSE AREAS

- A. Reseed all areas failing to show a uniform stand of grass after germination of seed, or damage through any cause before final acceptance.

3.8 INSPECTION AND SUBSTANTIAL COMPLETION

- A. After completion of all seeding, which follows the first mowing, the Landscape Architect will review the grass areas for adequacy. Areas not fully germinated with an uniform stand of grass, or areas damaged through any other cause prior to this inspection shall be reseeded as herein specified at the Contractor's expense. "Uniform stand of grass" is defined as a complete cover of lush, thriving, green grass with no bare spots greater than four (4) square inches. It must be emphasized the acceptance may occur after one mowing, but only when all of the other conditions of this project have been completely met. If the grass is not accepted after the mowing, maintenance and weekly mowing shall continue until acceptance. This additional maintenance may include disease control, special fertilizers, and other treatment as needed.

3.9 CLEANUP AND PROTECTION

- A. Promptly remove soil and debris created by lawn work from paved areas. Clean wheels of vehicles before leaving site to avoid tracking soil onto roads, walks, or other paved areas.
- B. Remove erosion-control measures after grass establishment period.

END OF SECTION 329200

**KOPACHUCK STATE PARK
DAY USE DEVELOPMENT**

SECTION 329300 - PLANTING

PART 1 - GENERAL

1.1 RELATED DOCUMENTS

- A. Drawings and general provisions of the Contract, including General Conditions and Division 1 Specification Sections, apply to this Section.

1.2 SUMMARY

- A. This Section includes:
 - 1. Installing plant material as shown on the Drawings.
 - 2. Installing fertilizer, mulch, and tree stakes.

1.3 RELATED SECTIONS

- A. Coordinate related work and requirements specified in other parts of the Contract Documents, including but not limited to the following:
 - 1. Section 329113 – Soil Mixes & Placement
 - 2. Section 329200 – Seeding

1.4 REFERENCES

- A. Refer to the following standards:
 - 1. WSDA Washington State Department of Agriculture - Rules Relating to Standards for Nursery Stock.
 - 2. American Standard for Nursery Stock, ANSI Z60.1-1990.
 - 3. Hortus Third, Cornell University.

1.5 DEFINITIONS

- A. Balled and Burlapped Stock: Exterior plants dug with firm, natural balls of earth in which they are grown, with ball size not less than sizes indicated or diameter and depth recommended by ANSI Z60.1 for type and size of tree or shrub required; wrapped, tied, rigidly supported, and drum-laced as recommended by ANSI Z60.1.
- B. Container Grown Plant: Exterior plants grown and marketed in a container which generally prevents the growth of roots beyond its side walls or bottom, with a fully developed root system which holds the rootball together when the container is removed. container and plant sizes shall not be less than sizes indicated or diameter and depth recommended by ANSI Z60.1 for type and size of shrub required.

**KOPACHUCK STATE PARK
DAY USE DEVELOPMENT**

- C. Finish Grade: Elevation of finished surface of planting soil.
- D. Planting Soil: See Section 329113 – Soil Mixes & Placement.
- E. Subgrade: Surface or elevation of subsoil remaining after completing excavation, or top surface of a fill or backfill, before placing planting soil.

1.6 SYSTEM DESCRIPTION

- A. Materials, equipment, and labor for planting; reestablishing finish grading of planting areas following planting; protection and immediate maintenance; guarantee and replacement; and related items necessary to complete the work indicated.
- B. Quantities: Determine exact amounts from Drawings.

1.7 SUBMITTALS

- A. Submit in accordance with Section 013300 - Submittal Procedures.
- B. Submit the following:
 - 1. Notification: Within 30 days after the award of Contract, submit documentation that plant materials have been ordered, purchase order number, and sample of each plant species.
- C. Product Data:
 - 1. Mulch
 - 2. Staking Materials
- D. Submit Maintenance Data. Include special directions essential for Owner's maintenance program during guarantee/warranty period. Include duplicate copies for landscaping maintenance personnel use during maintenance period.
- E. Warrantees:
 - 1. Plant Material Warranty: Written Warranty on Contractor's letterhead.
- F. Maintenance Data:
 - 1. Submit Maintenance Data as specified in Section 017700 - Closeout Procedures. Include special directions essential for Owner's maintenance program during guarantee/warranty period. Include duplicate copies for landscaping maintenance personnel use during maintenance period.
- G. Samples:
 - 1. Mulch – 1/2 cubic foot.

**KOPACHUCK STATE PARK
DAY USE DEVELOPMENT**

1.8 QUALITY ASSURANCE

- A. Supplier, installer qualifications: Contractor to have at least five years experience performing comparable work.
- B. Pre-Installation Meeting:
 - 1. All plants shall be reviewed by the Owner's Representative on site prior to planting.
 - 2. Stake all tree locations for approval prior to excavating pits.
 - 3. Plant five (5) shrubs and two (2) trees and stake in the presence of the Owner's Representative prior to planting all other shrubs and trees.

1.9 DELIVERY, STORAGE, AND HANDLING OF NEW PLANT MATERIAL

- A. Products Excluding Plant Materials:
 - 1. Labeling: Furnish standard products in unopened manufacturer's standard containers bearing original labels showing quantity, analysis and name of manufacturer.
 - 2. Storage: Store materials and products with protection from weather or other conditions which would damage or impair their effectiveness.
- B. Acceptance of Contractor-Procured Plant Materials:
 - 1. Owner acceptance of Plant Materials at Delivery: Owner's Representative to review plant materials upon delivery to verify that plants are undamaged, healthy and satisfactory for which to provide the Warranty requirements described in these Specifications.
 - 2. Unsatisfactory Conditions: Contractor to notify Owner's Representative immediately if unsatisfactory conditions are found that will not allow the plants to be warranted as described in these Specifications.
 - 3. Acceptance of Warranty Responsibility: The Contractor, by accepting delivery of plant material, without providing written notification of unsatisfactory conditions, assumes Warranty responsibilities for the plant material as described in these specifications.
 - 4. Unloading: The Contractor has responsibility for removing plant material from delivery vehicle.
 - 5. Protection Prior to Installation: Protect from sun and drying winds from delivery until planted in final location on site. Heel-in all rootballs if not planted the same day as delivered.
 - 6. Proper Plant Handling: Handle and protect plants, roots, rootballs, and new buds to prevent plant injuries. Pickup all plants from the rootball or container, not the trunk.
 - 7. Unsatisfactory Materials: Immediately remove unsatisfactory materials from site.
 - 8. Verification of Species: All plant material shall be delivered with tags or labels identifying species and variety (as applicable). Incorrect species shall be removed from the site immediately.
 - 9. Plant Tags: Do not remove yellow, plastic lock-seal tags with serial numbers until end of Warranty period.

**KOPACHUCK STATE PARK
DAY USE DEVELOPMENT**

1.10 PROJECT SITE CONDITIONS

- A. Environmental Requirements: Plant during periods normal for optimum growth, as determined by season, weather conditions, and accepted practice. Contractor may conduct planting operations under unseasonable conditions, without additional compensation, by accepting full responsibility for subsequent resulting losses.
- B. Underground Conditions:
 - 1. Locate utility lines and underground obstructions to avoid damage during excavation.
 - 2. Contractor shall repair and replace damaged buildings, equipment, underground utilities, paving, surfacing, stairs, and other work damaged as a result of Contractor's operations.
 - 3. Locate and clearly mark pipe, wire, valves, and other underground equipment.

1.11 SEQUENCING AND SCHEDULING

- A. Coordinate ordering of materials with Owner immediately following General Contract award. Ensure that specified sizes and quantities are furnished.
- B. Planting Schedule: Contractor is responsible for using good horticultural practices and judgment regarding timing of planting.

1.12 WARRANTY

- A. Warranty Period for this work is as stated in General Conditions and begins at Owner acceptance. Warranty period for all plant material shall be one year from date of Owner acceptance.
 - 1. Guarantee replacement: Acceptance of sample plants does not constitute acceptance of all plants. Final acceptance of plants shall occur at Owner acceptance of the completed project.
 - a. Plant materials: Warrant to be healthy and thriving.
 - b. Remove and replace immediately during the Guarantee Period: Dead, diseased, dying, broken, or missing plant materials (except as noted below). Use specified plant and plant as specified; guarantee until acceptable, active, healthy growth is evident.
 - c. Contractor's responsibility: During Guarantee Period, you are not held responsible for replacing plants destroyed or damaged by vandalism, accidents caused by vehicle (other than yours), or Acts of God, provided that you have exercised due care to protect the work.
 - d. When required replacement time falls during nonplanting season, you may request Owner's permission to defer planting until proper season. If granted, immediately remove dead plants, including roots, from site.
 - e. Backfill pits properly with topsoil. Finish grade and leave in acceptable condition until proper planting season occurs. Replace with plants of same kind and size as those originally planted. Plant as originally specified.

**KOPACHUCK STATE PARK
DAY USE DEVELOPMENT**

1.13 MAINTENANCE

- A. The maintenance period shall continue until substantial completion. At a minimum, maintenance shall include: watering, weed and pest control, and temporary barriers as required to insure healthy, thriving plant growth.

PART 2 - PRODUCTS

2.1 MATERIAL - GENERAL

- A. Comply with Quality Assurance provisions, references, specifications, and manufacturer's data.

2.2 PLANT MATERIALS

- A. Meet or exceed following reference standards for quality, size, and condition:
 - 1. WSDA Rules Related to Standards for Nursery Stock.
 - 2. ANSI Z60.1-2004: Nursery Stock.
 - 3. American Joint Committee of Horticultural Nomenclature: Standardized Plant Names.
- B. Plant abbreviations (see Drawings for complete plant list):

ABBREVIATION	DESCRIPTION
B&B	Balled and burlaped
BR	Bare root
cal	Caliper
cont	Container
dia	Diameter
gal	Gallon
S	Small
M	Medium
L	Large
EXL	Extra Large
NCN	No common name
oc	On center
tri-spaced	Triangular spaced

2.3 PLANTING SOIL

- A. As described in Section 329113 – Soil Mixes & Placement.

2.4 TREE STAKING & GUYING MATERIALS

- A. Stakes: Douglas fir with pointed end.

**KOPACHUCK STATE PARK
DAY USE DEVELOPMENT**

- B. Tree Guying "Arbortie": Flat woven flexible synthetic fiber $\frac{3}{4}$ " wide with a break strength of 900 lbs. Color: Olive Green. Available from Deep Root Partners, L.P., Burlingame, CA 1-800-458-7668.

2.5 MULCH

- A. A coarse grade material derived from well-decomposed yard waste. Compost shall be produced by a permitted solid waste composting facility. All pieces shall be smaller than 2" in any direction. Submit sample.
- B. Acceptable Products Available From:
 - 1. L.R.I. (253) 847-7555
 - 2. Cedar Grove Compost (877) 764-5748

PART 3 - EXECUTION

3.1 PRE-PLANTING INSPECTION

- A. General: Verify installation conditions as satisfactory to receive work of this section. Do not install until unsatisfactory conditions are corrected. Beginning work constitutes Contractor's acceptance of conditions as satisfactory.
- B. Contaminants:
 - 1. Verify existing soil conditions for contaminants that may have been discarded by other trades, such as thinner and plaster.
 - 2. Report findings in writing immediately to Owner's Representative before placing topsoil.
- C. Adverse Drainage Conditions: Notify Owner's Representative in writing of adverse drainage conditions affecting plant growth.

3.2 PREPARATION

- A. Field Measurements:
 - 1. Verify actual plant layout in relation to Drawings: Make adjustments as required by Owner's Representative.
- B. Plant Locations:
 - 1. Stake all tree locations with wood stakes for acceptance by Owner's Representative.
 - 2. Make required field adjustments as directed by Owner's Representative.
 - 3. Shrubs may be staked out by boundary rather than individual plants.
- C. Protect the public, adjacent properties, surfaces, and surrounding areas to prevent harm during Work of this Section.

**KOPACHUCK STATE PARK
DAY USE DEVELOPMENT**

3.3 INSTALLATION

- A. Install the Work in accordance with References and specifications.

3.4 FINISH GRADING

- A. Finish subgrade and obtain approval of Owner's Representative before you start planting or place any soil. Finish subgrade shall be smooth and conform to the final finish grade after soil placement. Allow for added soil in individual plantings as specified.

3.5 PLANTING

- A. Preparation:

1. Before planting, soak dry rootballs.
2. Prune broken roots 1/2 inch or greater in diameter. Make clean cuts.
3. Plant when plant materials are available and weather conditions are consistent with good horticultural practice.

- B. Plant Pits:

1. Dig plant pits and plant according to details. Waste excess pit spoils evenly over subgrade.
2. If you encounter clay soil or unusual conditions likely to be detrimental to new plantings, notify Owner's Representative immediately.
3. Remove unsuitable material excavated from plant holes and dispose of it legally off project site.
4. Install plants with POSITIVE drainage away from rootball, unless otherwise noted.

- C. Planting:

1. Hold plant in center of hole, approximately 2 inches above normal growing position and backfill with soil approximately halfway.
2. Backfill to within 5 inches of finish grade; fill hole with water and allow to settle.
3. Backfill to finish grade with specified planting soil.
4. Raise plants settling below finish grade to correct elevation.

- D. Plant Tags:

1. Remove and dispose of nursery labels, tags and stakes.
2. Do not remove yellow, plastic lock-seals with serial numbers until end of Warranty period.

**KOPACHUCK STATE PARK
DAY USE DEVELOPMENT**

3.6 TREE STAKING

- A. Stake as shown on Drawings.
 - 1. Tying Tree to Stakes:
 - a. Hold trunk in one hand, pull top to one side and release. Height at which trunk will snap back to upright is Base Height.
 - b. Attach tree ties to trunk 6 inches above Base Height.
 - c. Install "Arbortie" per manufacturer's instructions.
 - d. Cut off any remaining stake 2 inches above upper tree tie.

3.7 MULCHING

- A. Before installing mulch, obtain acceptance of the Owner's Representative of planting areas, grades, soil depths, and plant locations.
- B. Install mulch layer to the limits and depths as shown on the Drawings.
- C. At plant trunks and stems, taper mulch back from root ball crown so mulch does not touch bark.

3.8 FINAL INSPECTION

- A. Remove defective materials; in their place, install new materials, as specified. Furnish in same variety and current size of existing healthy plant materials, subject to 1-year guarantee beginning at the date of new installation. Remove any weeds.

3.9 CLEANING

- A. Sweep paving clean. Leave installations properly planted, clean, and orderly; premises free from scatterings and other residue of work. Leave site neat and clean at end of each working day.
 - 1. Remove and dispose on site such items as excess earth, clippings, trimmings, leaves, litter, and debris.
 - 2. Rake planting areas to an even, fine grade. Wash hard surfaces clean.
 - 3. Remove flag labels from plantings.

3.10 PROTECTION OF COMPLETED WORK

- A. Install barriers as necessary and required to protect the work during Guarantee Period, or for shorter period as directed.

**KOPACHUCK STATE PARK
DAY USE DEVELOPMENT**

3.11 PLANT ESTABLISHMENT

- A. Contactor to provide water to maintain plants during plant establishment and warranty periods.

END OF SECTION 329300

**KOPACHUCK STATE PARK
DAY USE DEVELOPMENT**

SECTION 331000- WATER UTILITY SYSTEM

PART 1 GENERAL

1.1 DESCRIPTION OF WORK

- A. The Work under this Section includes providing all labor, materials, tools and equipment necessary for furnishing and installing buried water pipe and water pipe fittings (including RPBA's, double check valves, and water service connections), electrical continuity, disinfection and testing. The Contractor shall install the water pipe and fittings to the horizontal and vertical alignment shown on the Plans and shall complete all associated Work described in this Section.

1.2 RELATED SECTIONS

- A. Section 312000- Earthwork (Utility Trenching)

1.3 REFERENCES

- A. ASTM International (ASTM)
 - 1. ASTM D2657 (2015) Standard Practice for Heat Fusion Joining of Polyolefin Pipe and Fittings
- B. American Water Works Association (AWWA)
 - 1. AWWA C151 (2009) Ductile-Iron Pipe, Centrifugally Cast
 - 2. AWWA C906 (2015) Polyethylene Pressure Pipe Fittings
- C. NSF International / American National Standard (NSF/ANSI)
 - 1. NSF/ANSI 61 Drinking Water System Components

1.4 SUBMITTALS

- A. Water Service Pipe product cut sheets
- B. Fittings and Valves cut sheets
- C. Testing and Disinfection Methods
- D. HDPE Pipe Welder Certifications
- E. To verify HDPE pipe weld procedures, submit test results from a sample weld prepared by the weld crews using the bent strap test in accordance with the Plastic Pipe Institute procedures

**KOPACHUCK STATE PARK
DAY USE DEVELOPMENT**

PART 2 PRODUCTS

2.1 PIPE AND FITTINGS

- A. All HDPE PIPE. High-density polyethylene (HDPE) pipe shall be in accordance with AWWA C906 and NSF/ANSI 61.
- B. Pipe material shall be high density polyethylene PE3408 conforming to minimum cell class 345 464 C, D, or E per ASTM D3350. Pipe diameter shall be either iron pipe size per Table 3 and Table 5 ANSI/AWWA C906 or ductile iron pipe size per Table 7 and Table 8 of ANSI/AWWA 906. Pipe pressure class shall be listed in Table 9 of ANSI/AWWA C 906 for DR 9 PE 3408 material.
- C. All water pipe shall be clearly marked with the manufacturer's name, type, class, and/or thickness as applicable. Lettering shall be legible and permanent under normal conditions of handling and storage.
- D. All water pipe shall be clearly marked with the manufacturer's name, type, class, and/or thickness as applicable. Lettering shall be legible and permanent under normal conditions of handling and storage.
- E. HDPE fittings shall be SDR 9 IPS in accordance with AWWA C906 and NSF/ANSI 61.
- F. Brass fittings shall be meet or exceed the pressure rating of the adjoin pipes and conform to AWWA C906 and NSF/ANSI 61.
- G. When HDPE pipe is connected to pipe accessories, a flange adapter may be used. HDPE flange adapters shall be manufactured by the same manufacturer as the pipe and use the same resin as the pipe.
- H. Connection of the pipe and fittings shall be performed by the thermal butt fusion system. HDPE pipe lengths, fittings, and flange adapter connections to be fused shall be of the same type, grade and class of polyethylene compound and supplied by the same raw material supplier.

2.2 CONNECTIONS

- A. When HDPE pipe is connected to accessories pipe a flange adapter may be used. A flange coupling adapter shall be used on accessory, HDPE flange adapters shall be manufactured by the same manufacturer as the pipe using the same resin as the pipe.
- B. Connection of the pipe and fittings shall be performed by the thermal butt fusion system. HDPE pipe lengths, fittings, and flange adapter connections to be fused shall be of the same type, grade and class of polyethylene compound and supplied by the same raw material supplier.

**KOPACHUCK STATE PARK
DAY USE DEVELOPMENT**

2.3 UNDERGROUND LOCATOR TAPE

- A. Underground locator tape shall be blue, six inch wide, 4 mil thick, polyethylene tape with black lettering with the following wording: "Caution: Water Line Buried Below". Locator tape shall be installed twelve inches above the top of all water pipe.
- B. Water mains and services lines are to be provided with tracer wire. The tracer wire must be 10 gauge solid core insulated copper wire. All splices, and terminating ends must be fitted with pre-filled gel winged wire connectors, designed for direct burial applications. The tracer wire must be installed directly on top of all water mains/lines.

2.4 EQUIPMENT AND MISCELLANEOUS

- A. All vaults and double check valves shall comply with the project plans and COGH standard details.
- B. All thrust blocking shall provide a minimum resistance of 3,000 pounds.
- C. Water meters shall be Master Meter, positive displacement or equal.
- D. Hydrants must be the Traffic Model type with approved breakaway features, with a center operating nut. All hydrants must be brass to brass subseat, minimum valve opening of 5¼ inches O ring stem seal, 6 inch mechanical or flange shoe connection, 1-1/4 inch pentagonal operating nut. Hydrants must have at least two 2-1/2 inch hose ports with caps, which must have National Standard male threads. The pumper port must be 4-1/2 inches in diameter with National Standard male thread. The pumper port must be provided with a 4-inch Storz assembly.

PART 3 EXECUTION

3.1 GENERAL

- A. The Contractor shall preserve and protect all existing utilities and other facilities including but not limited to: telephone, television, electrical, water and sewer utilities, surface or storm drainage, highway or street signs, mail boxes, or survey monuments. The Contractor shall immediately repair or replace utilities or other facilities damaged during construction. The Contractor shall support and protect any underground utility conduits, pipes, or service lines where they cross the trench.
- B. The Contractor shall give at least 48 hours' notice to the water purveyor prior to:
 - 1. Interruption of water service in any area; or
 - 2. Use of water from any fire hydrant.
- C. Any water service disruption shall be restored as soon as possible. The Contractor shall notify water purveyor of a planned water service disruption.
- D. Contractor and Fabricator to verify all fit-ups prior to order.

**KOPACHUCK STATE PARK
DAY USE DEVELOPMENT**

3.2 INSTALLATION

- A. Water pipe shall be installed in accordance with the manufacturer's printed specifications and instructions, and in conformance with AWWA C151 and NSF/ANSI 61.
- B. The water pipe shall be handled carefully to prevent damage to the pipe, pipe lining, or coating. Water pipe and fittings shall be loaded and unloaded using hoists and slings to avoid shock or damage, and under no circumstances shall they be dropped, skidded, or rolled. If any part of the coating or lining is damaged, repair thereof shall be made in a manner satisfactory to the Engineer at the Contractor's expense. All water pipe and fittings shall be inspected for defects. Damaged pipe will be rejected and the Contractor shall immediately place all damaged pipe apart from the undamaged and shall remove the damaged pipe from the site within 24 hours.
- C. Whenever it becomes necessary to cut a length of water pipe, the cut shall be made by abrasive saw or by special pipe cutter.
- D. All pipe ends shall be square with the longitudinal axis of the water pipe and shall be reamed and smoothed to assure a good connection.
- E. The water pipe shall be laid to the horizontal and vertical alignment shown on the plans. A minimum five (3) foot cover shall be maintained from finish grade to top of water pipe. Fittings shall be installed at the location shown on the plans, or as required.
- F. Water encountered during trenching operations shall be removed and/or controlled to prevent entry of water and other deleterious material into the pipe and fittings.
- G. To prevent dirt and other foreign material from entering the pipe and fittings during handling and installation, the open end of the pipe shall be protected by a water tight plug at all times, except when jointing the next section of pipe.
- H. Under no circumstances shall pipe deflections, either horizontal or vertical, exceed the manufacturer's printed recommendations. Where deflections would exceed the manufacturer's recommendations, fittings shall be used.
- I. Vertical deflections to avoid obstructions that exceed allowable water pipe joint deflections shall be accomplished by the use of fittings, and either joint restraints or vertical thrust blocking conforming to the plans. Additional fittings to those indicated on the plans will be required to accomplish these vertical deflections.
- J. All joints within 50 feet of tees, or bends greater than, or equal to 45 degrees Fahrenheit, shall be restrained.
- K. Continuous water service shall be provided for all structures, except for interruptions necessary for connection of temporary or new piping to the existing service or mainline piping.
- L. Interruption of water service to the resident ranger, disconnected or interrupted as a part of this Project, shall be limited to four (4) hours. Notification of the resident ranger affected by any water service interruptions shall be made a minimum of 24 hours in advance of the interruption of service.

**KOPACHUCK STATE PARK
DAY USE DEVELOPMENT**

- M. Installation of HDPE pipe shall comply with manufacturer printed specifications. The Contractor shall ensure appropriate and proper fit up prior to installation.

3.3 HYDROSTATIC TESTING

- A. Comply with Pierce County standards.
- B. All water mains, water services, and appurtenances must be hydrostatically tested in accordance with AWWA Manual 41 and AWWA Manual 44, Chapter 3.
- C. Any exposed pipe, fittings, valves, hydrants, and joints must be examined carefully during the test. Any damage or defective pipe, fittings, valves, hydrants, or joints that are discovered following the pressure test must be repaired or replaced with reliable material; and the test must be repeated until satisfactory results are obtained.
- D. Testing allowance must be defined as the quantity of makeup water that must be supplied to the newly laid pipe, or any valved section thereof, to maintain pressure within 5 psi of the specified test pressure after the pipe has been filled with water and the air expelled.
- E. All pumps, gauges, plugs, saddles, corporation stops, miscellaneous hose and piping, and measuring equipment necessary for performing the test must be furnished, sanitized, and operated by the Developer.
- F. The pipeline must be backfilled sufficiently to prevent movement of the pipe under pressure. All thrust blocks will be in place and time allowed for the concrete to cure before testing. Where permanent blocking is not required, the Developer must furnish and install temporary blocking and remove it after testing. All physical connections to the existing water system must be removed prior to the test.
- G. The mains must be filled with water and allowed to stand under pressure a sufficient length of time to allow air to escape and the lining of the pipe to absorb water. The City will furnish the water necessary to fill the pipelines for testing purposes at a time of day when sufficient quantities of water are available for normal system operation.
- H. The test must be accomplished by pumping the main up to the required pressure, stopping the pump for 2 hours, and then pumping the main up to the test pressure again. During the test, exposed sections of pipe being tested must be observed to detect any visible leakage. A clean container must be used for holding water for pumping up pressure on the main being tested. This makeup water must be disinfected by the addition of chlorine to a concentration of 50 mg/l.

**KOPACHUCK STATE PARK
DAY USE DEVELOPMENT**

- I. Prior to the acceptance of the work, all new water lines must be subjected to a hydrostatic pressure test of 240 psi for 15 minutes with no pressure loss or leakage. The pressure testing pump must be located at the high point of the line unless otherwise approved by the Engineer. Any leaks developed must be remedied by the Developer before final acceptance of the work. Prior to testing, reasonable effort must be made by the Developer to remove all air in the lines. The mains must be tested between valves. If possible, no hydrostatic pressure must be placed against the opposite side of the valve being tested. Test pressure must be maintained while the entire installation is inspected. The Contractor must provide all necessary equipment and must perform all work connected with the test. If the test does not pass inspection for any reason, additional inspections required to witness the test must be done at the Contractors' expense.
- J. All tests must be successfully completed and approved by the Engineer before the new system may be connected to the existing system. A temporary plug (or 2 inch blow-off assembly on lines without hydrants) must be installed at the end of the new main. This must include concrete blocking necessary to withstand pressures encountered during the hydrostatic test.
- K. Any visible leakage detected must be corrected by the Contractor, regardless of the testing requirements specified above. Should the tested section fail to meet the pressure test successfully, as specified, the Contractor must locate and repair the defects and re-test the pipeline.
- L. All tests must be made with the hydrant auxiliary gate valves open and pressure against the hydrant valve. After the test has been completed, each gate valve must be tested by closing each in turn and relieving the pressure beyond. This test of the gate valve will be acceptable if there is no immediate loss of pressure on the gauge when the pressure comes against the valve being checked. The Contractor must verify that the pressure differential across the valve does not exceed the rated working pressure of the valve.
- M. Prior to requesting the presence of the Pierce County inspector and Engineer to witness the pressure test, the Contractor must have all equipment set up and completely ready for operation and must have performed the pretest to ensure that the pipe is in a satisfactory condition.
- N. Defective materials or workmanship, discovered as a result of the hydrostatic field test, must be replaced by the Contractor. Whenever it is necessary to replace defective material or correct the workmanship, the hydrostatic test must be rerun at the Contractor's expense until a satisfactory test is obtained.

3.4 FLUSHING, TESTING, AND DISINFECTION

- A. Before being placed in service, all newly-installed pipe must be flushed and chlorinated, and a satisfactory bacteriological report obtained.
- B. No chlorination treatments must be allowed to remain in the water main over weekends or holidays. Chlorination treatment must be flushed from the water main between 24 and 48 hours of application.
- C. Disinfection of water mains must be performed in accordance with AWWA Standard C-651-92.
- D. No connection may be made between the existing distribution system and pipelines that are not disinfected.

**KOPACHUCK STATE PARK
DAY USE DEVELOPMENT**

- E. The Contractor must obtain the approval of the Pierce County inspector prior to the installation or use of any backflow prevention assembly. To obtain the required flow for flushing on pipes sizes less than 8 inches in diameter, the backflow prevention assembly must be at least 4 inches. For pipe diameters between 8 and 18 inches, the backflow prevention assembly must be at least 6 inches.
- F. Water mains must be flushed between 24 and 48 hours of chlorination. No flushing will be allowed on weekends or on holidays. The Contractor must notify the Engineer and Pierce County Inspector a minimum of 48 hours in advance of flushing or flow testing.
- G. Samples must be collected and Contractor is responsible for payment of all bacteriological testing.
- H. Water used to disinfect and flush mains must be dechlorinated and treated prior to discharge to the stormwater system.
- I. Chlorine must be applied by one of the methods from the AWWA Manual on Disinfection of Pipelines and Storage Facilities Field Guide
- J. The preferred point of application of the chlorinating agent is at the beginning of the pipeline extension or at any valved section of it, and through a corporation stop inserted into the horizontal axis of the pipe. The water injector for delivering the chlorine-bearing water into the pipe should be supplied from a tap on the pressure side of the gate valve controlling the flow into the pipeline extension.
- K. Water from the existing distribution system, or other source of supply, must be controlled to flow very slowly into the newly-laid pipeline during application of the chlorine. The rate of chlorine gas/water mixture or dry gas feed must be in such proportion to the rate of water entering the newly-laid pipe that the dosage applied will be at least 50mg/l.
- L. All water mains must be flushed between 24 and 48 hours of chlorination. No flushing will be allowed on weekends or on holidays. The Developer must notify the City construction inspector a minimum of two working days in advance of any flushing or flow testing.
- M. Sections of pipe to be disinfected must first be flushed to remove any solids or contaminated material that may have become lodged in the pipe.
- N. Following chlorination, all treated water must be flushed from the newly-laid pipe until the replacement water throughout its length shows, upon testing, the absence of chlorine. In the event chlorine is normally used in the source of supply, then the tests must show a residual not in excess of that carried by the system.
- O. Should the initial treatment result in an unsatisfactory bacteriological test, chlorination must be repeated until satisfactory results have been obtained.

**KOPACHUCK STATE PARK
DAY USE DEVELOPMENT**

- P. Before being placed into service, all new mains must be chlorinated so that a chlorine residual of not less than 25 mg/l remains in the water after standing for a minimum of 24 hours in the pipe (maximum standing time is 48 hours). The initial chlorine content of the water must not be less than 50 mg/l.

END OF SECTION 331000

**KOPACHUCK STATE PARK
DAY USE DEVELOPMENT**

SECTION 333000- SANITARY SEWER

PART 1 GENERAL

1.1 DESCRIPTION OF WORK

- A. The Work under this Section includes providing all labor, materials, tools and equipment necessary for furnishing and installing sanitary sewer gravity lines and sanitary force mains.

1.2 RELATED SECTIONS

- A. Section 312000 – Earthwork (Utility Trenching)

1.3 REFERENCES

- A. ASTM International (ASTM)
 1. ASTM D3034 (2016) Standard Specification for Type PSM Poly(Vinyl Chloride) (PVC) Sewer Pipe and Fittings
 2. ASTM D5926 (2015) Standard Specification for Poly (Vinyl Chloride) (PVC) Gaskets for Drain, Waste, and Vent (DWV), Sewer, Sanitary, and Storm Plumbing Systems
 3. ASTM F679 (2016) Standard Specification for Poly(Vinyl Chloride) (PVC) Large-Diameter Plastic Gravity Sewer Pipe and Fittings
 4. ASTM D1785 (2016) Standard Specification for Poly(Vinyl Chloride) (PVC) Schedules 40, 80 and 120.
 5. ASTM F477 (2014) Standard Specification for Elastomeric Seals (Gaskets) for Joining Plastic Pipe

1.4 SUBMITTALS

- A. Gravity Sewer Pipe and fittings: Material certifications stating conformance with the requirements of this Section.
- B. Pressure Pipe and Fittings: Material certifications for pipe and fittings meeting the requirements of this Section. Provide pressure testing plan and procedures.
- C. Manufacturer's product information for cleanout frame and lid.
- D. Air Release Valve and Structure: Manufacturer data and material certifications.

PART 2 PRODUCTS

2.1 UNDERGROUND LOCATOR TAPE

- A. Underground locator tape shall be green, at least 4 inches wide, four mil thick, polyethylene tape, with a metallic backing capable of being traced with locators. The tape shall have black letters with the following wording: "Caution: Sewer Line Buried Below." The locator tape shall be installed 12 inches above the top of all sewer lines, force mains and services.

**KOPACHUCK STATE PARK
DAY USE DEVELOPMENT**

2.2 PVC PIPE

- A. Sanitary gravity sewer pipe shall be PVC solid wall, DR35 conforming to the requirements of ASTM D3034 with leak proof fittings.
- B. On sewer distribution laterals and fittings shall be PVC Schedule 40 per ASTM D 1785. All fittings shall use a manufacturer approved primer and solvent cement.

2.3 FORCE MAIN HDPE PIPE

- A. HDPE Pipe: High-density polyethylene (HDPE) pipe shall be DR 9 and 7 where identified on the plans
- B. HDPE Fittings: HDPE fittings shall be DR 9 and 7 where identified on the plans.
- C. HDPE Connections: When HDPE pipe is connected to accessories pipe a flange adapter or treaded stainless steel transition fitting may be used.
- D. Connection of the pipe and fittings shall be performed by the thermal butt fusion system. HDPE pipe lengths, fittings, and flange adapter connections to be fused shall be of the same type, grade and class of polyethylene compound and supplied by the same raw material supplier.

2.4 FRAMES AND GRATES

- A. Castings are to be load rated as indicated on the drawings. If not indicated, load ratings shall be HS-25, and shall be hinged and gasketed.

PART 3 EXECUTION

3.1 CONSTRUCTION

- A. Excavation, bedding, and backfill shall conform to the requirements of Section 312000 – Earthwork (Utility Trenching). Underground marking tape shall be installed as shown on the Detail.
- B. Sheeting and bracing required for trenches shall be removed to the elevation of the conduit, but no sheeting will be allowed to be pulled, removed, or disturbed below the conduit. Sheeting and bracing shall meet OSHA requirements.
- C. Before lowering into the trench, the pipe shall be inspected for defects. All cracked, chipped, or broken pipe shall be discarded. The ends and interior of the pipe shall be clean. Belled ends shall be laid up grade. Handling of the pipe shall be accomplished in a manner that will not damage the pipe. The joint shall be made in the manner recommended by the manufacturer. Care shall be taken not to buckle or disturb previously laid
- D. Pipe shall be laid accurately to the staked line and grade. Where existing service sewers are to be connected, suitable fittings and adapters shall be provided by the Contractor.
- E. Pipe shall be cleaned of all foreign matter, and water shall be kept out of trenches until joints have been completed. When Work is not in progress, open ends of pipe and fittings shall be securely closed to keep foreign matter and animals from entering.

**KOPACHUCK STATE PARK
DAY USE DEVELOPMENT**

- F. Each joint shall be inspected to ensure that it is properly made before backfilling is done. Care shall be taken to prevent any dirt or foreign matter from entering the open end of the pipe. Where it is necessary to cut pipe, such cuts shall be neatly made in an approved manner. The laid pipe shall be true to line and grade and, when completed, the sewer shall have a smooth and uniform invert. No section of gravity sewer, including service connections shall have an adverse grade which would pond water in the invert of the sewer.
- G. Connections to existing sewer mains, service connections, and manholes shall be made in such a manner so as to not damage the existing facility. Such connections shall be made so that no projections or rough surfaces occur within the pipe.
- H. Pressure Pipe Installation (Polyethylene ½-inch to 4-inch diameter)
 - 1. Comply with manufacturer's recommendations.
 - 2. Field-adjust pipe routing to avoid conflicts and provide required slope.
 - 3. Join pipe with fittings, connectors, and fasteners providing full diameter flow. Heat fusion is acceptable.
 - 4. Minimum radius of curvature: Comply with manufacturer's specification. Provide smooth transitions.
- I. Sewer Pressure Laterals
 - 1. Ensure all joints are property glued per manufacturer's instructions
 - 2. Drill orifices per drawings and install in the proper position
 - 3. Install cleanouts per drawings at the end of each pressure lateral

3.2 CLEANOUTS

- A. Comply with County and WSDOT Standards.
- B. Construct plumb and level.
- C. Adjust top to finish grade. Verify top of cleanout elevation.

3.3 SITE TOLERANCES

- A. Variance from established line and grade for gravity sewers shall not be greater than 1/32 of an inch per inch of pipe diameter and or not to exceed ½-inch, provided that such variation does not result in a level or reverse sloping invert.
- B. Allowable deviation shall not be accumulative.
- C. Sewer shall be constructed to provide the cover and direction of slope as shown.
- D. The slope need not be constant but no high or low points shall exist in finished installation except as shown.

3.4 PRESSURE PIPE LEAKAGE TESTING

- A. The Contractor shall furnish all facilities and personnel for conducting the test under the observation of the Engineer. The equipment and personnel shall be subject to the approval of the Engineer.
- B. All pressure pipe shall be tested to 150 psi for a minimum of 2 hours in accordance with AWWA C600 hydrostatic testing requirements. Loss of water pressure during test shall not exceed 5 psi.

**KOPACHUCK STATE PARK
DAY USE DEVELOPMENT**

- C. The pipe shall be slowly filled with water taking care to remove all air before applying the specified test pressure with the pump.
- D. Pipe that fails to meet the test requirements shall be repaired and retested as necessary until the test requirements are complied with.

END OF SECTION 333000

**KOPACHUCK STATE PARK
DAY USE DEVELOPMENT**

SECTION 333200- ON-SITE SEWAGE SYSTEM

PART 1 GENERAL

1.1 DESCRIPTION OF WORK

- A. The Work under this Section includes providing all labor, materials, tools and equipment necessary for furnishing and installing the onsite sewage system in accordance with these Specifications and in conformity with the Drawings.
- B. This Work includes demolishing existing septic tanks, furnishing, installing and connecting new septic tanks, pump, pump chamber, distribution box and pressure laterals.

1.2 RELATED SECTIONS

- A. Section 312000 – Earthwork (Utility Trenching)
- B. Section 333000 – Sanitary Sewer

1.3 REFERENCES

- A. ASTM International (ASTM)
 - 1. 246-272A WAC- Washington State On-Site Sewage System Regulations
 - 2. ASTM D3034 (2016) Standard Specification for Poly (Vinyl Chloride) (PVC) Sewer Pipe and Fittings
 - 3. ASTM D1785 (2016) Standard Specification for Poly (Vinyl Chloride) (PVC) Schedules 40, 80 and 120.
 - 4. ASTM F477 (2014) Standard Specification for Elastomeric Seals (Gaskets) for Joining Plastic Pipe

1.4 SUBMITTALS

- A. Septic Tanks: Material certifications and shop drawings for vault, internal plumbing, lid, and penetrations.
- B. Pump Chamber: Material certifications and shop drawings for vault, lid, and penetrations for the pump chamber.
- C. Pump and Controls: Material certification for pipe and fittings meeting the requirement of this section.
- D. Distribution Box: Manufacturer’s product information for distribution box
- E. Installer Certification: Installer’s current certification from Pierce County Health Department

**KOPACHUCK STATE PARK
DAY USE DEVELOPMENT**

- F. Construction Records: As-built drawing and recorded measurements as detailed in these Specifications during system startup.
- G. Owner's Manual: Recommended maintenance activities and frequency as detailed in these Specifications.

PART 2 PRODUCTS

2.1 SEPTIC TANKS

- A. Septic tanks shall have two compartments, must be in compliance with WAC 246-272A-0232
- B. Shall be watertight with service access manholes and monitoring ports for the inlet and outlet
- C. Provide access riser minimum diameter of 24-inch and airtight gasket on the lid to eliminate odors.

2.2 PUMP CHAMBER

- A. Pump chamber shall be single compartment and must meet same compliance as septic tanks (2.01)
- B. Provide a sediment shroud as indicated on the drawings around the pump

2.3 PUMP AND BACKUP PUMP

- A. All pumps and electrical components must be UL approved and meet requirements for Class I, Division I locations per WA Department of Labor and Industries.
- B. Two pumps shall be provided, one will be installed and the second will be provided as a backup pump.
- C. Pumps shall be a submersible sewage pump, 2" solids handling and minimum 3" discharge.
- D. Pumps performance shall be 66 gpm at 52 feet of head.
- E. Pumps shall be ceramic double seal model with stainless steel motor shaft.
- F. Provide check valve inside of pump chamber accessible from the surface, equipped with unions so it can be replaced if necessary.
- G. Pump must be installed to allow removal from the surface without entering the chamber and equipped with the necessary unions, valves and electrical connections for removal and repair.

**KOPACHUCK STATE PARK
DAY USE DEVELOPMENT**

2.4 PUMP CONTROLS

- A. Pump control panel shall be UL approved, rated for outdoor exposure, visible from the pump chamber equipped with both audible and visual high liquid level alarms.
- B. Float bulb switches mounted so they can be easily replaced and/or adjusted without removing the pump.
- C. Panel must be equipped with cycle counter and hour meter.

2.5 DISTRIBUTION BOX

- A. Castings are to be load rated as indicated on the drawings. If not indicated, load ratings shall be HS-25, and shall be hinged and gasketed.

PART 3 EXECUTION

3.1 PRECONSTRUCTION

- A. All system components must be installed by a certified installer
- B. Installer must contact Engineer to release the permit
- C. Installer will pick up permit and post on site

3.2 DEMOLITION

- A. Existing septic tank and crib structure shall be demolished
- B. Pump out existing structures with approved company
- C. Remove existing structures from site and dispose at a certified facility, backfill with imported clean gravel fill material.
- D. Submit decommissioning certificate form to local health department

3.3 CONSTRUCTION

- A. Excavation, bedding, and backfill shall conform to the requirements of Section 31 20 00 – Earthwork (Utility Trenching).
- B. Sheeting and bracing required for trenches shall be removed to the elevation of the conduit, but no sheeting will be allowed to be pulled, removed, or disturbed below the conduit. Sheeting and bracing shall meet OSHA requirements.
- C. Before lowering into the trench, the pipe and structures shall be inspected for defects.

**KOPACHUCK STATE PARK
DAY USE DEVELOPMENT**

- D. Structure and pipe shall be laid accurately to the staked line and grade.
- E. Structures and pipe shall be cleaned of all foreign matter, and water shall be kept out of trenches until joints have been completed.
- F. Each joint and structure penetrations shall be inspected to ensure that it is properly made before backfilling is done.

3.4 INSPECTIONS AND STARTUP

- A. Upon system completion the installer is to notify the Engineer for inspection prior to backfill
- B. The Engineer will inspect the system for compliance and notify the local health department for final inspection
- C. If any deficiencies are noted, they must be corrected before installation is approved
- D. After final approval, the system will be backfilled by the installer
- E. The installer shall provide a startup of the system to ensure the system is operating properly and make any necessary adjustments as required.

3.5 POST CONSTRUCTION

- A. The installer shall prepare and submit construction records including as-builts with the following information:
 - 1. All the items contained in the design submittal listed above, as installed, identifying any changes from the approved plan,
 - 2. The measured drawdown per dose cycle,
 - 3. Timer functions,
 - 4. Residual pressure and/or squirt height at the end of each lateral, as inspected, and
 - 5. Pump run time and pump time off.
- B. The installer shall prepare and submit User's Manual with the following information:
 - 1. Diagrams of the system components,
 - 2. Explanation of general system function, operations expectations, owner responsibility, etc,
 - 3. Specifications of all electrical and mechanical components installed (occasionally components other than those specified on the plans are used),
 - 4. Names and telephone numbers of the system designer, local health jurisdiction, component manufacturers, supplier/installer, and/or the management entity to be contacted in the event of failure,
 - 5. Information on the periodic maintenance requirements of the various components of the sewage system, and
 - 6. Information on "trouble-shooting" common operational problems that might occur.

**KOPACHUCK STATE PARK
DAY USE DEVELOPMENT**

3.6 MONITORING

- A. The installer shall perform a 6-month system inspection and prepare a summary report with the following information:
1. Evaluate Drainfield
 - a. For indications of surfacing effluent
 - b. For appropriate vegetation, landscaping impacts, ponds, etc.
 - c. For absence of heavy traffic
 - d. For inappropriate building
 - e. For impervious materials or surfaces
 - f. For abnormal settling or erosion.
 2. Evaluate Laterals
 - a. For residual pressure at the distal ends. Confirms that it is the same as those recorded on the construction record. If not the same, laterals and orifices need to be cleaned.
 - b. For equal flows in each lateral.
 - c. For need for cleaning. Clean lateral and orifices as necessary.
 3. Measure Pump Run Time per Cycle and Drawdown
 - a. Compare these values with those recorded in the construction record. If not the same, evaluate the system for improperly set timer control, float switches, clogged laterals, and plugged orifices.
 4. Test Alarms
 - a. Test alarms for proper functioning (high and low liquid level).
 5. Evaluate Septic Tank and Pump Chamber
 - a. For sludge and scum accumulations; pump when the sludge and scum thickness total 1/3 of the depth of the tank.
 - b. For clogging, damage, and proper placement of outlet baffle screen. Clean each time it is inspected or as needed to avoid clogging.
 - c. For signs of leaking in tanks and risers. Repair or replace if necessary.
 - d. For risers and lids being above grade and having lids that are secure.
 - e. For properly functioning of floats. Movement should not be restricted. Floats should be positioned correctly and provide positive instrumental signals. Adjust and repair as necessary.
- B. All findings shall be provided in a final report along with any necessary repairs. Provide copy of report to Washington State Parks and local health department.

END OF SECTION 333200

**KOPACHUCK STATE PARK
DAY USE DEVELOPMENT**

SECTION 334100 - SUBDRAINAGE

PART 1 - GENERAL

1.1 RELATED DOCUMENTS

- A. Drawings and general provisions of the Contract, including General Conditions and Division 1 Specification Sections, apply to this Section.

1.2 SUMMARY

- A. This Section includes subdrainage systems for the following:
 - 1. Retaining Walls.
 - 2. PVC Catch Basins.
 - 3. Trench Drains.

1.3 DEFINITIONS

- A. HDPE: High-density polyethylene.
- B. PE: Polyethylene.

1.4 SUBMITTALS

- A. Product Data: For drainage conduit, drainage panels, and geotextile fabrics.
 - 1. Perforated HDP pipe and fittings.
 - 2. Perforated polyethylene pipe (PP) and fittings.
 - 3. Drainage aggregate.
 - 4. Geotextile fabric.
- B. Submit composite data sheets on all materials. See Part 2 "Sampling of Permeable Materials", for submittal requirements.

PART 2 - PRODUCTS

2.1 GENERAL

- A. All materials used in the drainage system shall be new and of the type specified.

**KOPACHUCK STATE PARK
DAY USE DEVELOPMENT**

2.2 POLYETHYLENE PIPE AND FITTINGS

- A. Perforated polyethylene pipe (PP) shall be virgin polyethylene, coiled, corrugated drain tubing, manufactured in accordance with ASTM F-405, Standard Specifications for Corrugated Polyethylene Tubing and Fittings.
- B. Pipe shall be flexible with circumferential ribbing for maximum strength. For perforated pipe (PP) the perforation shall be a minimum of three rows at 120-degree angles. Perforations shall be of the "saw-cut" variety or of sufficiently small circular holes to not permit passage of pea gravel.
- C. Fittings shall be of the same manufacture as the pipe and shall be of the "snap-on" type.
- D. Lengths of tubing shall be joined by split couplings. Tape for wrapping of split couplings shall be polyethylene material.
- E. Corrugated-perforated pipe and corrugated pipe shall be Advance Drainage System (ADS) or approved equal.

2.3 HIGH DENSITY POLYETHYLENE PIPE (HDP) AND FITTINGS

- A. Perforated HDP drain pipe and fittings shall be High Density Polyethylene (HDP) conforming to HDP pipe shall be AASHTO M252, Type S smooth interior, corrugated exterior pipe, N-12, manufactured by Advanced Drainage Systems; Hi-Q pipe as manufactured by Hancor, Inc. or approved equal. Fittings shall be of the same manufacture as the pipe and shall be of the "snap-on" type. Lengths of tubing shall be joined by split couplings.

2.4 PVC CATCH BASINS FRAMES AND GRATES

A. PVC Drain Basins:

- 1. Shall be manufactured from PVC pipe stock, utilizing a thermos-molding process to reform the pipe stock to the specified configuration.
- 2. The drainage pipe connection stubs shall be manufactured from PVC pipe stock and formed to provide watertight connection with the specified pipe system.
- 3. Joint tightness shall conform to ASTM D3212 Standard Specification for Joints for Drain and Sewer Plastic Pipe Using Flexible Elastomeric Seals. The flexible elastomeric seals shall conform to ASTM F477.
- 4. The pipe bell spigot shall be joined to the main body of the drain basin or catch basin.
- 5. The raw material used to manufacture the pipe stock that is used to manufacture the main body and pipe stubs of the surface drainage inlets shall conform to ASTM D1784 cell class 12454.
- 6. Approved Product: Nyloplast or approved equal.

B. Grates and Frames:

- 1. PVC Catch Basin Grate: Cast Iron Round Domed grate, standard finish. Use adaptor to PVC drain basin as required.

**KOPACHUCK STATE PARK
DAY USE DEVELOPMENT**

2.5 TRENCH DRAINS

- A. Trench drain shall be as manufactured by ACO Drain, Model K100S Channel with Grate Type 478.
- B. In-Line Trench Drain Catch Basin shall be as manufactured by ACO Drain, Model K900 with integral galvanized steel trash bucket.
- C. Approved Equal: Zurn Z-886 Channel with HDP (ADA compliant) grate.

2.6 DRAINAGE AGGREGATE

- A. All aggregate used in the drainage trench shall be pea gravel, washed, per the following:
 - 1. Pea Gravel

SIEVE SIZE	PERCENT PASSING
#1/2	100
#3/8	95 – 100
#5/16	80 – 90
#1/4	10 – 50
#4	1 – 20
#8	0 - 1

- B. Drainpipe aggregate gravel shall be used as the envelope around the corrugated polyethylene drain piping from the bottom of the pipe trench to the level of the existing native material subgrade.

2.7 GEOTEXTILE FABRIC

- A. Material: Mirafi 140N or approved equal.

2.8 SAMPLING OF PERMEABLE MATERIALS

- A. Prior to the importation of any of the permeable materials, the Contractor shall provide the Owner with a ½ cubic foot sample and with a certified test lab report of the sieve analysis of the product listing compliance with the same sieve sizes specified. Owner shall be the final determining factor in establishing compliance with sieve requirements. No material shall be brought onto the job site until the initial sieve analysis has been approved by the Owner, in writing. The testing laboratory shall be an independent, professional laboratory, approved by the Owner.
- B. During the course of importation of the permeable materials, the Contractor shall be responsible for continually checking the materials to insure that they continue to meet the Specifications. Failure to do so may require that the Contractor remove non-qualifying material from the site at his own cost. The Owner will have the option to take random samples for testing at their own laboratory. In the event that any sample taken and tested by the Owner reveals that non-qualifying material is being imported, the Contractor shall cease all importation until the Owner

**KOPACHUCK STATE PARK
DAY USE DEVELOPMENT**

is assured that the Contractor is meeting the specifications. In the event that the Owner's sieve analysis and the Contractor's sieve analysis are at variance, and either analysis reveals the material to be non-complying, the Contractor shall be responsible for obtaining the services of a third-party professional testing laboratory, which, in turn shall analyze samples selected by the Owner. Such analysis shall be turned over to the Owner for resolution.

- C. The certified test lab reports required in paragraph above, shall be submitted by the Contractor as early as possible to avoid potential delays in the Contract due to sample rejections.

PART 3 - EXECUTION

3.1 FINISH SUBGRADE

- A. Verify that the subgrade depths are correct and as shown on the drawings. Tolerance of subgrade See Section 310000 – Earthwork. Subgrade must be in a smooth, even condition prior to trenching.

3.2 TRENCHING

- A. Excavation: Trenches shall be cut with smooth sides, no less width than as shown on the drawings. All trench spoils removed from the under drained areas may be used as fill in other on-site areas. In the event that the trench has been over excavated, the Contractor may correct the cut by use of the gravel filler material, as long as the invert elevations of the drainpipe and the minimum gravel filter blanket are as specified. All trenches shall have loose material removed from the trench bottom before any bedding gravel shall be placed. Trench bottom shall be smooth and compact and to the grade specified.
- B. Trench Maintenance: All trenches shall be maintained with vertical sides and without loose or sloughed materials therein; care shall be taken in placement of gravel to ensure no sloughing of trench sides or contamination of the gravel.
- C. The Contractor shall not drive rubber-tired vehicles across excavated trenches unless trenches are bridged with ½" steel sheeting (approximately 4' x 8' size). During delivery of materials, trucks shall be guided by a field worker to ensure no trenches are crossed without protection.
- D. All excavations over four feet (4') deep shall be in conformance with WISHA shoring regulations and Standard Specifications (WSDOT), Section 7-17.3(1).

3.3 GEOTEXTILE FABRIC

- A. Install in strict conformance with manufacturer's recommendations and as detailed.

3.4 PEA GRAVEL ENVELOPE

- A. Pea gravel shall be placed in properly graded and approved trenches for the drainpipe with lines and grades per the plans. The gravel shall be carefully placed in the clean and graded geofabric lined trench bottom (and sides) and brought to the appropriate level, no less than 2" at any point.

**KOPACHUCK STATE PARK
DAY USE DEVELOPMENT**

The drainpipe shall be placed on the bedding and the balance of the filler gravel shall be placed on the pipe and brought up to finish subgrade level. Gravel shall be placed along the sides of the pipe and the top of the pipe with the pipe held in place to prevent vertical or lateral displacement by the fluid effort of the gravel.

3.5 POLYETHYLENE PIPE INSTALLATION

- A. Polyethylene drainpipe shall be uncoiled and cut to length and then permitted to remain in the uncoiled position until excessive set induced by coiling is relieved. Pipe shall be laid on the bed to grade and held to prevent displacement. Pipe shall be end-capped at the ends. Pipe shall be coupled with snap-on couplings to ensure locking of the couplings and shall be wrapped with two wraps of polyethylene tape (one tape width).

3.6 HIGH DENSITY POLYETHYLENE PIPE INSTALLATION

- A. Install piping beginning at low points of system, true to grades and alignment indicated, with unbroken continuity of invert. Bed piping with full bearing in drainage aggregate. Install couplings according to manufacturer's written instructions and other requirements indicated.

3.7 PVC DRAIN CATCH BASINS AND TRENCH DRAINS

- A. Install in strict conformance with manufacturer's instructions.

END OF SECTION 334100

**KOPACHUCK STATE PARK
DAY USE DEVELOPMENT**

SECTION 334400- STORM DRAIN UTILITY

PART 1 GENERAL

1.1 DESCRIPTION OF WORK

- A. The Work in this Section shall include all labor, materials, tools and equipment necessary to furnish and install the following items and all other related Work in accordance with the requirements of the Contract Documents and as shown on the Plans.

1. Storm Drain Pipe
2. Catch Basins and Manholes
3. Stormwater Treatment Vault

1.2 RELATED SECTIONS

- A. Section 312000 – Earthwork (Utility Trenching)
- B. Section 334100 – Subdrainage.

1.3 REFERENCES

- A. American Association of State Highway and Transportation Officials (AASHTO)
1. AASHTO M252 (2009) Standard Specification for Corrugated Polyethylene Drainage Pipe
 2. AASHTO M278 (2015) Standard Specification for Class PS46 Poly(Vinyl Chloride) (PVC) Pipe
 3. AASHTO M294 (2016) Standard Specification for Corrugated Polyethylene Pipe, 300- to 1500-mm (12- to 60-in.) Diameter
- B. ASTM International (ASTM)
1. ASTM F477 (2014) Standard Specification for Elastomeric Seals (Gaskets) for Joining Plastic Pipe
 2. ASTM F2487 (2013) Standard Practice for Infiltration and Exfiltration Acceptance Testing of Installed Corrugated High Density Polyethylene and Polypropylene Pipelines^{1, 2}
- C. Pierce County Stormwater Manual.
- D. Washington State Department of Transportation (WSDOT)
1. (2018) Standard Specification for Road, Bridge, and Municipal Construction; and Amendments

**KOPACHUCK STATE PARK
DAY USE DEVELOPMENT**

1.4 SUBMITTALS

- A. Product Data: Catalog cut sheets and specifications for pipe, fittings, manholes, catch basins, trench drains, castings, treatment systems and accessories.
- B. Project Data: Stormwater structure and treatment system shop drawings.
- C. Manufacturer's Installation Instructions: Indicate special procedures required to install products specified.
- D. Manholes and drainage structures to be designed in accordance with the live load factor requirements in the most current version of ASHTO Standard Specifications for Highway Bridges.
- E. Record Documents:
 - 1. Provide field survey of all inverts and structure lid elevations.
 - 2. Identify and describe unexpected variations to subsoil conditions not noted on Drawings.
 - 3. Identify and describe discovery of uncharted utilities not noted on drawings.
 - 4. Prepare As-Built Drawings per contract requirements.

1.5 QUALITY ASSURANCE

- A. Qualifications:
 - 1. Crew Foreman: Minimum eight years working experience and four years' experience as foreman performing similar work.
 - 2. Surveyor: Land surveyor licensed in state of Washington with experience on similar projects.
- B. Regulatory Requirements: Comply with Pierce County Standards.

PART 2 PRODUCTS

2.1 GENERAL

- A. Comply County Standards.
- B. Comply with WSDOT Standard Specifications.

2.2 STORM DRAIN

- A. Pipe and Coupling Bands: Per WSDOT Standard Specifications Section 9-05; use water tight couplings for all pipes.

**KOPACHUCK STATE PARK
DAY USE DEVELOPMENT**

- B. Corrugated polyethylene pipe (CPEP) shall be high density corrugated polyethylene (HDPE) smooth interior pipe, and shall be manufactured in conformity with the latest AASHTO M294, Type S.
- C. Fittings shall be water tight according to the requirements of AASHTO M252 and AASHTO M294, and gaskets shall meet ASTM F477.
- D. All Pipes, to assure water tightness, field performance shall be tested in accordance with ASTM F2487.
- E. Pipe bedding shall meet WSDOT 9-03.12(3).
- F. PVC PIPE:
 - 1. PVC shall be PVC 1120 Type 1 Grade 1, with a cell class of 12454B, per ASTM D1784. Produce in compliance to ASTM D1785. Pipe for drainage shall be Schedule 40 installed per ASTM D2855. The joints should conform to ASTM D2672, the solvent cement to ASTM D2564 and the primer to ASTM F656.
 - 2. Perforations shall be 2 rows of holes, 120° apart, parallel to the axis of the pipe. Holes shall be 1/2" in diameter and are on 5" center.

2.3 CATCH BASINS AND INLETS

- A. Comply with County Standards.
- B. Load rating: Structures to be load rated as indicated on drawings, if not indicated minimum load rating shall be HS-20.
- C. Catch Basins:
 - 1. Catch Basin Type 1 per WSDOT standard plan B-5.20-0.
 - 2. Catch Basin Type II per WSDOT standard plan B-10.20-00 and B-30.10-00.

2.4 METAL CASTINGS

- A. Comply with County Standards.
- B. Load rating: Castings to be load rated as indicated on drawings, if not indicated minimum load rating shall be HS-20.
- C. Ring and Cover: WSDOT standard plan B-30.20-0 Lettering "STORM".
- D. Frame and Grate: WSDOT standard plan B-5.20-0.
- E. Locking type.
- F. Grates in pedestrian access areas comply with ADA requirements.

**KOPACHUCK STATE PARK
DAY USE DEVELOPMENT**

- G. Round Cast Iron Bee Hive Grate: Where shown.
- H. Swale Grate: Neenah #3205 swale grate and locking frame.

2.5 CONCRETE

- A. Minimum f'c of 3,000 psi.

2.6 STORMWATER TREATMENT SYSTEM

A. General Notes

- 1. Manufacturer to provide all materials unless otherwise noted.
- 2. All dimensions, elevations, specifications, and capacities are subject to change. For project specific drawings detailing exact dimension, weights and accessories please contact manufacturer.

B. Stormwater Treatment Systems shall be Modular Subsurface Wetlands Systems (MSDWS) from BIOCLEAN – Environmental Services, Inc.

- 1. All stormwater treatment systems and appurtenances shall be HS20 load rated.
- 2. MLS Stormwater Treatment System –
 - a. Inlet/Outlet Pipe: 18” Diameter
 - b. Rim Elev: 35.50
 - c. Surface Load: HS-20
 - d. Frame and Cover: 24” Diameter and 30” Diameter
 - e. Wetland Media Volume: 4.30 CY
 - f. Orifice Size: 2.21”

PART 3 EXECUTION

3.1 EXAMINATION

A. Site Verification of Conditions

- 1. Verify excavation is ready to receive Work; and excavations, dimensions, and elevations are as indicated on Drawings.
- 2. Verify existing utilities are marked.
- 3. Verify erosion control is in place and operating as specified.

3.2 PREPARATION

A. Protection

- 1. Protect elements surrounding Work from damage or disfiguration.

**KOPACHUCK STATE PARK
DAY USE DEVELOPMENT**

2. Protect existing utilities from damage and disturbance. Provide shoring to support existing utilities and their support prism or remove and replace utilities where shoring is practical.
3. Field locate and mark existing utilities, whether shown or not, before construction and avoid damage or disturbance. For aid in utility location call 1-800-424-5555, 48 hours (two working days) before beginning construction.
4. Field stake alignment and grade.
5. Maintain existing drainage during construction. Provide temporary ditches, drains, pipe, sumps, and pumps as required.

3.3 CONSTRUCTION

A. Excavation:

1. Comply with Section 31 20 00 – Earthwork (Utility Trenching)
2. Remove stones larger than 2 inches or other hard matter which could damage piping or impede consistent backfilling or compaction.

B. Pipe:

1. Install per manufacturer's recommended procedures, ASTM standards, and WSDOT Standard Specifications.
2. Maintain line and grade per Drawings.
3. Join pipe per Manufacturer's recommended procedures and WSDOT Standard Specifications.
4. Pipe Bedding shall conform to Section 312000 – Earthwork (Utility Trenching)

C. Stormwater Treatment, Catch Basins and Storm Drain Manholes, Contractor shall:

1. Comply with manufacturers recommendations.
2. Comply with WSDOT Section 7-05.
3. Form bottom of excavation clean and smooth to correct elevation.
4. Place base sections on 12-inch-thickness minimum compacted bedding. Smooth and level to ensure uniform contact and support. Where sub grade cannot be compacted due to excess moisture, provide lean concrete pad with minimum 12 inches thick.
5. Extend bedding to limits of excavation.
6. Compact bedding to 95 percent of maximum density per ASTM D1557. Verify alignment and elevation of entering pipes.
7. Construct structures plumb and level.
8. Make completed manhole rigid, true to dimensions, and water tight.
9. Backfill evenly around structure to prevent displacement and unequal stresses.
10. Ensure lift holes are wet and fill with mortar inside and out.
11. Smooth and point structure joints inside and out. Ensure water tightness.
12. Remove loops flush with inside wall surface after manhole is completed for pre-cast manhole elements where steel loops are provided in lieu of lift holes.
13. Remove sharp cutoff protrusions. If concrete spalling occurs as a result of loop removal, restore spalled area to a uniform smooth surface with cement mortar.

D. Stormwater Treatment System

**KOPACHUCK STATE PARK
DAY USE DEVELOPMENT**

1. Contractor to provide all labor, equipment, materials, and incidentals required to offload and install the system and appurtenances in accordance with this drawing and the manufactures specifications, unless otherwise stated in manufactures contract.
2. Unit must be installed on level base of minimum 6” level rock base. Contractor is responsible to verify project engineers recommended base specifications.
3. All pipes must be flush with inside surface of concrete. (Pipes cannot intrude beyond flush). Invert of outflow pipe must be flush with discharge chamber floor. All gaps around pipes shall be sealed water tight with a non-shrink grout per manufacturers standard connection detail and shall meet or exceed regional pipe connection standards.
4. Contractor to supply and install all external connecting pipes.
5. Contractor responsible for installation of all risers, manholes, and hatches. Contractor to grout all manholes and hatches to match finished surface unless specified otherwise.

3.4 FIELD QUALITY CONTROL

- A. Compaction Testing: Per Section 312000 – Earthwork (Utility Trenching)
- B. Engineer Inspection: After completion of pipe, catch basins, manholes, cleanouts, trench drains, and bedding, and before backfilling.

3.5 CLEANING

- A. Before final acceptance, flush accumulated construction debris and remove other foreign matter from storm drains. Do not allow flushed material to enter downstream system.

END OF SECTION 334400